

- **Military Operating Temperature Range**
- 55°C to 125°C

- **Performance Ranges:**

	ACCESS TIME	ACCESS TIME	ACCESS TIME	ACCESS TIME
	ROW ADDRESS (MAX)	COLUMN ENABLE (MAX)	SERIAL DATA (MAX)	SERIAL ENABLE (MAX)
	$t_{a(R)}$	$t_{a(C)}$	$t_{a(SQ)}$	$t_{a(SE)}$
'44C251B-10	100 ns	25 ns	30 ns	20 ns
'44C251B-12	120 ns	30 ns	35 ns	25 ns

- **Class B High-Reliability Processing**
- **DRAM: 262144 Words × 4 Bits**
SAM: 512 Words × 4 Bits
- **Single 5-V Power Supply (±10% Tolerance)**
- **Dual Port Accessibility—Simultaneous and Asynchronous Access From the DRAM and SAM Ports**
- **Bidirectional-Data-Transfer Function Between the DRAM and the Serial-Data Register**
- **4 × 4 Block-Write Feature for Fast Area Fill Operations; As Many as Four Memory Address Locations Written per Cycle From an On-Chip Color Register**
- **Write-Per-Bit Feature for Selective Write to Each RAM I/O; Two Write-Per-Bit Modes to Simplify System Design**

- **Enhanced Page-Mode Operation for Faster Access**
- **CAS-Before-RAS (CBR) and Hidden Refresh Modes**
- **All Inputs/Outputs and Clocks Are TTL Compatible**
- **Long Refresh Period**
Every 8 ms (Max)
- **Up to 33-MHz Uninterrupted Serial-Data Streams**
- **3-State Serial I/Os Allow Easy Multiplexing of Video-Data Streams**
- **512 Selectable Serial-Register Starting Locations**
- **Packaging:**
 - 28-Pin J-Leaded Ceramic Chip Carrier Package (HJ Suffix)
 - 28-Pin Leadless Ceramic Chip Carrier Package (HM Suffix)
 - 28-Pin Ceramic Sidebraced DIP (JD Suffix)
 - 28-Pin Zig-Zag In-Line (ZIP), Ceramic Package (SV Suffix)
- **Split Serial-Data Register for Simplified Real-Time Register Reload**

description

The SMJ44C251B multiport video RAM is a high-speed, dual-ported memory device. It consists of a dynamic random-access memory (DRAM) organized as 262144 words of 4 bits each interfaced to a serial-data register or serial-access memory (SAM) organized as 512 words of 4 bits each. The SMJ44C251B supports three types of operation: random access to and from the DRAM, serial access to and from the serial register, and bidirectional transfer of data between any row in the DRAM and the serial register. Except during transfer operations, the SMJ44C251B can be accessed simultaneously and asynchronously from the DRAM and SAM ports.

PIN NOMENCLATURE

A0-A8	Address Inputs
CAS	Column Enables
DQ0-DQ3	DRAM Data In-Out/Write-Mask Bit
SE	Serial Enable
RAS	Row Enable
SC	Serial Data Clock
SDQ0-SDQ3	Serial Data In-Out
TRG	Transfer Register/Q Output Enable
W	Write-Mask Select/Write Enable
DSF	Special Function Select
QSF	Split-Register Activity Status
VCC	5-V Supply
VSS	Ground
GND	Ground (Important: Not connected to internal VSS)

SMJ44C251B
262144 BY 4-BIT
MULTIPORT VIDEO RAM

SGMS058A - MARCH 1995 - REVISED JUNE 1995

pinouts

HJ PACKAGE
(TOP VIEW)

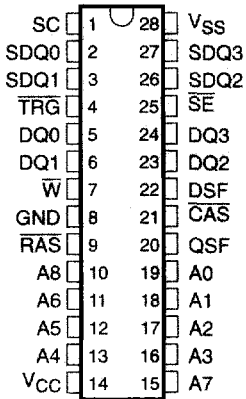

HM PACKAGE
(TOP VIEW)

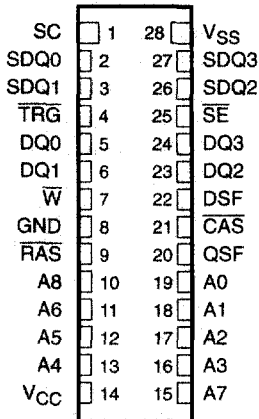

JD PACKAGE
(TOP VIEW)

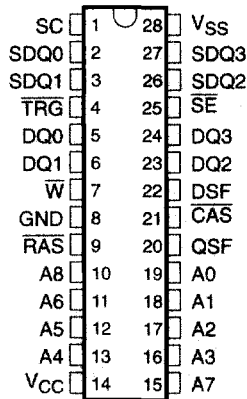

SV PACKAGE
(TOP VIEW)

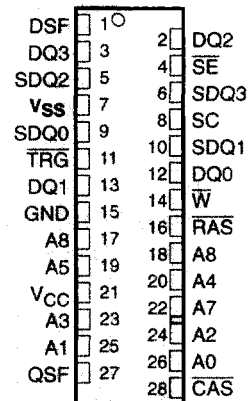

description (continued)

During a transfer operation, the 512 columns of the DRAM are connected to the 512 positions in the serial data register. The 512 × 4-bit serial-data register can be loaded from the memory row (transfer read), or the contents of the 512 × 4-bit serial-data register can be written to the memory row (transfer write).

The SMJ44C251B is equipped with several features designed to provide higher system-level bandwidth and to simplify design integration on both the DRAM and SAM ports. On the DRAM port, greater pixel draw rates can be achieved by the device's 4 × 4 block-write mode. The block-write mode allows four bits of data (present in an on-chip color-data register) to be written to any combination of four adjacent column-address locations. As many as 16 bits of data can be written to memory during each $\overline{\text{CAS}}$ cycle time. Also on the DRAM port, a write mask or a write-per-bit feature allows masking any combination of the four input/outputs on any write cycle. The persistent write-per-bit feature uses a mask register that, once loaded, can be used on subsequent write cycles. The mask register eliminates having to provide mask data on every mask-write cycle.

The SMJ44C251B offers a split-register transfer read (DRAM to SAM) feature for the serial tester (SAM port). This feature enables real-time register reload implementation for truly continuous serial data streams without critical timing requirements. The register is divided into a high half and a low half. While one half is being read out of the SAM port, the other half can be loaded from the memory array. For applications not requiring real-time register reload (for example, reloads done during CRT retrace periods), the single-register mode of operation is retained to simplify design. The SAM can also be configured in input mode, accepting serial data from an external device. Once the serial register within the SAM is loaded, its contents can be transferred to the corresponding column positions in any row in memory in a single memory cycle.

The SAM port is designed for maximum performance. Data can be input to or accessed from the SAM at serial rates up to 33 MHz. During the split-register mode of operation, internal circuitry detects when the last bit position is accessed from the active half of the register and immediately transfers control to the opposite half. A separate output, QSF, is included to indicate which half of the serial register is active at any given time in the split-register mode.

All inputs, outputs, and clock signals on the SMJ44C251B are compatible with Series 54 TTL devices. All address lines and data-in lines are latched on-chip to simplify system design. All data-out lines are unlatched to allow greater system flexibility.



SMJ44C251B
262144 BY 4-BIT
MULTIPOINT VIDEO RAM

SGMS058A - MARCH 1995 - REVISED JUNE 1995

Function Table

FUNCTION	RAS FALL					CAS FALL	ADDRESS		DQ0-DQ3		TYPE†
	CAS	TRG	W‡	DSF	SE	DSF	RAS	CAS	RAS	CAS§ W	
CBR refresh	L	X	X	X	X	X	X	X	X	X	R
Register-to-memory transfer (transfer write)	H	L	L	X	L	X	Row Addr	Tap Point	X	X	T
Alternate transfer write (independent of SE)	H	L	L	H	X	X	Row Addr	Tap Point	X	X	T
Serial-write-mode enable (pseudo-transfer write)	H	L	L	L	H	X	Refresh Addr	Tap Point	X	X	T
Memory-to-register transfer (transfer read)	H	L	H	L	X	X	Row Addr	Tap Point	X	X	T
Split-register-transfer read (must reload tap)	H	L	H	H	X	X	Row Addr	Tap Point	X	X	T
Load and use write mask, Write data to DRAM	H	H	L	L	X	L	Row Addr	Col Addr	DQ Mask	Valid Data	R
Load and use write mask, Block write to DRAM	H	H	L	L	X	H	Row Addr	Blk Addr A2-A8	DQ Mask	Col Mask	R
Persistent write-per-bit, Write data to DRAM	H	H	L	H	X	L	Row Addr	Col Addr	X	Valid Data	R
Persistent write-per-bit, Block write to DRAM	H	H	L	H	X	H	Row Addr	Blk Addr A2-A8	X	Col Mask	R
Normal DRAM read/write (nonmasked)	H	H	H	L	X	L	Row Addr	Col Addr	X	Valid Data	R
Block write to DRAM (nonmasked)	H	H	H	L	X	H	Row Addr	Blk Addr A2-A8	X	Col Mask	R
Load write mask	H	H	H	H	X	L	Refresh Addr	X	X	DQ Mask	R
Load color register	H	H	H	H	X	H	Refresh Addr	X	X	Color Data	R

Legend:

H = High

L = Low

X = Don't care

† R = random access operation; T = transfer operation

‡ In persistent write-per-bit function, W must be high during the refresh cycle.

§ DQ0-DQ3 are latched on the later of W or CAS falling edge.

Col Mask = H: Write to address/column location enabled

DQ Mask = H: Write to I/O enabled



operation

Depending on the type of operation chosen, the signals of the SMJ44C251B perform different functions. Table 1 summarizes the signal descriptions and the operational modes they control.

Table 1. Detailed Signal Description Versus Operational Mode

PIN	DRAM	TRANSFER	SAM
A0-A8	Row, column address	Row, tap address	
$\overline{\text{CAS}}$	Column enable, output enable	Tap-address strobe	
DQ _i	DRAM data I/O, write mask bits		
DSF	Block-write enable Persistent write-per-bit enable Color-register load enable	Split-register enable Alternate write-transfer enable	
$\overline{\text{RAS}}$	Row enable	Row enable	
$\overline{\text{SE}}$		Serial-in mode enable	Serial enable
SC			Serial clock
SDQ			Serial-data I/O
$\overline{\text{TRG}}$	Q output enable	Transfer enable	
$\overline{\text{W}}$	Write enable, write-per-bit select	Transfer-write enable	
QSF			Split register Active status
NC/GND	Make no external connection or tie to system V_{SS} .		
V_{CC}	5-V supply (typical)		
V_{SS}	Device ground		

The SMJ44C251B has three kinds of operations: random-access operations typical of a DRAM, transfer operations from memory arrays to the SAM, and serial-access operations through the SAM port. The signals used to control these operations are described here, followed by discussions of the operations themselves.

address (A0-A8)

For DRAM operation, 18 address bits are required to decode one of the 262 144 storage cell locations. Nine row-address bits are set up on A0-A8 and latched onto the chip on the falling edge of $\overline{\text{RAS}}$. Nine column-address bits are set up on A0-A8 and latched onto the chip on the falling edge of $\overline{\text{CAS}}$. All addresses must be stable on or before the falling edges of $\overline{\text{RAS}}$ and $\overline{\text{CAS}}$.

During the transfer operation, the states of A0-A8 are latched on the falling edge of $\overline{\text{RAS}}$ to select one of the 512 rows where the transfer occurs. To select one of 512 tap points (starting positions) for the serial-data input or output, the appropriate 9-bit column address (A0-A8) must be valid when $\overline{\text{CAS}}$ falls.

row-address strobe ($\overline{\text{RAS}}$)

$\overline{\text{RAS}}$ is similar to a chip enable because all DRAM cycles and transfer cycles are initiated by the falling edge of $\overline{\text{RAS}}$. $\overline{\text{RAS}}$ is a control input that latches the states of row address, $\overline{\text{W}}$, $\overline{\text{TRG}}$, $\overline{\text{SE}}$, $\overline{\text{CAS}}$, and DSF onto the chip to invoke DRAM and transfer functions.

column-address strobe ($\overline{\text{CAS}}$)

$\overline{\text{CAS}}$ is a control input that latches the states of column address and DSF to control DRAM and transfer functions. When $\overline{\text{CAS}}$ is brought low during a transfer cycle, it latches the new tap point for the serial-data input or output. $\overline{\text{CAS}}$ also acts as an output enable for the DRAM outputs DQ0-DQ3.

SMJ44C251B
262144 BY 4-BIT
MULTIPOINT VIDEO RAM

SGMS058A – MARCH 1995 – REVISED JUNE 1995

output enable/transfer select ($\overline{\text{TRG}}$)

$\overline{\text{TRG}}$ selects either DRAM or transfer operation as $\overline{\text{RAS}}$ falls. For DRAM operation, $\overline{\text{TRG}}$ must be held high as $\overline{\text{RAS}}$ falls. During DRAM operation, $\overline{\text{TRG}}$ functions as an output enable for the DRAM outputs DQ0–DQ3. For transfer operation, $\overline{\text{TRG}}$ must be brought low before $\overline{\text{RAS}}$ falls.

write-mask select, write enable ($\overline{\text{W}}$)

In DRAM operation, $\overline{\text{W}}$ enables data to be written to the DRAM. $\overline{\text{W}}$ is also used to select the DRAM write-per-bit mode. Holding $\overline{\text{W}}$ low on the falling edge of $\overline{\text{RAS}}$ invokes the write-per-bit operation. The SMJ44C251B supports both the normal write-per-bit mode and the persistent write-per-bit mode.

For transfer operation, $\overline{\text{W}}$ selects either a read-transfer operation (DRAM to SAM) or a write-transfer operation (SAM to DRAM). During a transfer cycle, if $\overline{\text{W}}$ is high when $\overline{\text{RAS}}$ falls, a read transfer occurs; if $\overline{\text{W}}$ is low, a write transfer occurs.

special function select (DSF)

DSF is latched on the falling edge of $\overline{\text{RAS}}$ or $\overline{\text{CAS}}$, similar to an address. DSF determines which of the following functions are invoked on a particular cycle:

- Persistent write-per-bit
- Block write
- Split-register transfer read
- Mask-register load for the persistent write-per-bit mode
- Color-register load for the block-write mode

DRAM data I/O, write-mask data (DQ0–DQ3)

DRAM data is written via DQ terminals during a write or read-modify-write cycle. In an early-write cycle, $\overline{\text{W}}$ is brought low prior to $\overline{\text{CAS}}$ and the data is strobed in by $\overline{\text{CAS}}$ with data setup and hold times referenced to this signal. In a delayed-write or read-modify-write cycle, $\overline{\text{W}}$ is brought low after $\overline{\text{CAS}}$ and the data is strobed in by $\overline{\text{W}}$ with data setup and hold times referenced to this signal.

The 3-state DQ output buffers provide direct TTL compatibility (no pullup resistors) with a fanout of two Series 54 TTL loads. Data out is the same polarity as data in. The outputs are in the high-impedance (floating) state as long as $\overline{\text{CAS}}$ and $\overline{\text{TRG}}$ are held high. Data does not appear at the outputs until both $\overline{\text{CAS}}$ and $\overline{\text{TRG}}$ are brought low. Once the outputs are valid, they remain valid while $\overline{\text{CAS}}$ and $\overline{\text{TRG}}$ are low. $\overline{\text{CAS}}$ or $\overline{\text{TRG}}$ going high returns the outputs to the high-impedance state. In a register-transfer operation, the DQ outputs remain in the high-impedance state for the entire cycle.

The write-per-bit mask is latched into the device via the random DQ terminals by the falling edge of $\overline{\text{RAS}}$. This mask selects which of the four random I/Os are written.

serial data I/O (SDQ0–SDQ3)

Serial inputs and serial outputs share common I/O terminals. Serial-input or serial-output mode is determined by the previous transfer cycle. If the previous transfer cycle was a read transfer, the data register is in serial-output mode. While in serial-output mode, data in SAM is accessed from the least significant bit to the most significant bit. The data registers operate modulo 512; so after bit 511 is accessed, the next bits to be accessed are 00, 01, 02, etc. If the previous transfer cycle was either a write transfer or a pseudo transfer, the data register is in serial-input mode and signal data can be input to the register.

serial clock (SC)

Serial data is accessed in or out of the data register on the rising edge of SC. The SMJ44C251B is designed to work with a wide range of clock-duty cycles to simplify system design. There is no refresh requirement because the data registers that comprise the SAM are static. There is also no minimum SC clock operating frequency.



serial enable (\overline{SE})

During serial-access operations \overline{SE} is used as an enable/disable for SDQ in both the input and output modes. If \overline{SE} is held as \overline{RAS} falls during a write-transfer cycle, a pseudo-transfer write occurs. There is no actual transfer, but the data register switches from the output mode to the input mode.

no connect/ground (NC/GND)

NC/GND is reserved for the manufacturer's test operation. It is an input and should be tied to system ground or left floating for proper device operation.

special function output (QSF)

During split-register operation the QSF output indicates which half of the SAM is being accessed. When QSF is low, the serial-address pointer is accessing the lower (least significant) 256 bits of SAM. When QSF is high, the serial-address pointer is accessing the higher (most significant) 256 bits of SAM. QSF changes state upon crossing the boundary between the two SAM halves in the split-register mode.

During normal transfer operations QSF changes state upon completing a transfer cycle. This state is determined by the tap point being loaded during the transfer cycle.

power up

To achieve proper device operation, an initial pause of 200 μ s is required after power-up, followed by a minimum of eight \overline{RAS} cycles or eight CBR cycles, a memory-to-register transfer cycle, and two SC cycles.

SMJ44C251B
262144 BY 4-BIT
MULTIPOINT VIDEO RAM

SGMS058A – MARCH 1995 – REVISED JUNE 1995

random-access operation

The random-access operation functions are summarized in Table 2 and described in the following sections.

Table 2. Random-Access-Operation Functions

FUNCTION	RAS FALL					CAS FALL	ADDRESS		DQ0–DQ3	
	CAS	TRG	WT	DSF	SE	DSF	RAS	CAS	RAS	CAS [†] W
CBR refresh	L	X	X	X	X	X	X	X	X	X
Load and use write mask, Write data to DRAM	H	H	L	L	X	L	Row Addr	Col Addr	DQ Mask	Valid Data
Load and use write mask, Block write to DRAM	H	H	L	L	X	H	Row Addr	Blk Addr A2–A8	DQ Mask	Col Mask
Persistent write-per-bit, Write data to DRAM	H	H	L	H	X	L	Row Addr	Col Addr	X	Valid Data
Persistent write-per-bit, Block write to DRAM	H	H	L	H	X	H	Row Addr	Blk Addr A2–A8	X	Col Mask
Normal DRAM read/write (nonmasked)	H	H	H	L	X	L	Row Addr	Col Addr	X	Valid Data
Block write to DRAM (nonmasked)	H	H	H	L	X	H	Row Addr	Blk Addr A2–A8	X	Col Mask
Load write mask	H	H	H	H	X	L	Refresh Addr	X	X	DQ Mask
Load color register	H	H	H	H	X	H	Refresh Addr	X	X	Color Data

Legend:

H = High

L = Low

X = Don't care

[†] In persistent write-per-bit function, \overline{W} must be high during the refresh cycle.

[‡] DQ0–DQ3 are latched on the later of \overline{W} or \overline{CAS} falling edge.

Col Mask = H: Write to address/column location enabled

DQ Mask = H: Write to I/O enabled

enhanced page mode

Enhanced page-mode operation allows faster memory access by keeping the same row address while selecting random column addresses. This mode eliminates the time required for row address setup-and-hold and address multiplex. The maximum RAS low time and the CAS page cycle time used determine the number of columns that can be accessed.

Unlike conventional page-mode operation, the enhanced page mode allows the SMJ44C251B to operate at a higher data bandwidth. Data retrieval begins as soon as the column address is valid rather than when \overline{CAS} transitions low. A valid column address can be presented immediately after row-address hold time has been satisfied, usually well in advance of the falling edge of \overline{CAS} . In this case, data can be obtained after $t_{a(C)}$ max (access time from \overline{CAS} low), if $t_{a(CA)}$ max (access time from column address) has been satisfied.

refresh

There are three types of refresh available on the SMJ44C251B: \overline{RAS} -only refresh, CBR refresh, and hidden refresh.



RAS-only refresh

A refresh operation must be performed to each row at least once every 8 ms to retain data. Unless $\overline{\text{CAS}}$ is applied, the output buffers are in the high-impedance state, so the RAS-only refresh sequence avoids any output during refresh. Externally generated addresses must be supplied during RAS-only refresh. Strobing each of the 512 row addresses with $\overline{\text{RAS}}$ causes all bits in each row to be refreshed. $\overline{\text{CAS}}$ can remain high (inactive) for this refresh sequence to conserve power.

CAS-before-RAS (CBR) refresh

CBR refresh is accomplished by bringing $\overline{\text{CAS}}$ low earlier than $\overline{\text{RAS}}$. The external row address is ignored and the refresh row address is generated internally when using CBR refresh. Other cycles can be performed in between CBR cycles without disturbing the internal address generation.

hidden refresh

A hidden refresh is accomplished by holding $\overline{\text{CAS}}$ low in the DRAM-read cycle and cycling $\overline{\text{RAS}}$. The output data of the DRAM-read cycle remains valid while the refresh is being carried out. Like the CBR refresh, the refreshed row addresses are generated internally during the hidden refresh.

write-per-bit

The write-per-bit feature allows masking of any combination of the four DQs on any write cycle (see Figure 1). The write-per-bit operation is invoked only when $\overline{\text{W}}$ is held low on the falling edge of $\overline{\text{RAS}}$. If $\overline{\text{W}}$ is held high on the falling edge of $\overline{\text{RAS}}$, write-per-bit is not enabled and the write operation is performed to all four DQs. The SMJ44C251B offers two write-per-bit modes: the nonpersistent write-per-bit mode and the persistent write-per-bit mode.

nonpersistent write-per-bit

When DSF is low on the falling edge of $\overline{\text{RAS}}$, the write mask is reloaded. A 4-bit code (the write-per-bit mask) is input to the device via the random DQ terminals and latched on the falling edge of $\overline{\text{RAS}}$. The write-per-bit mask selects which of the four random I/Os are written and which are not. After $\overline{\text{RAS}}$ has latched the on-chip write-per-bit mask, input data is driven onto the DQ terminals and is latched on the later falling edge of $\overline{\text{CAS}}$ or $\overline{\text{W}}$. When a data low is strobed into a particular I/O on the falling edge of $\overline{\text{RAS}}$, data is not written to that I/O. When a data high is strobed into a particular I/O on the falling edge of $\overline{\text{RAS}}$, data is written to that I/O.

persistent write-per-bit

When DSF is high on the falling edge of $\overline{\text{RAS}}$, the write-per-bit mask is not reloaded: it retains the value stored during the last write-per-bit mask reload. This mode of operation is known as persistent write-per-bit because the write-per-bit mask is persistent over an arbitrary number of write cycles. The write-per-bit mask reload can be done during the nonpersistent write-per-bit cycle or by the mask-register-load cycle.

SMJ44C251B
262144 BY 4-BIT
MULTIPOINT VIDEO RAM

SGMS058A - MARCH 1995 - REVISED JUNE 1995

persistent write-per-bit (continued)

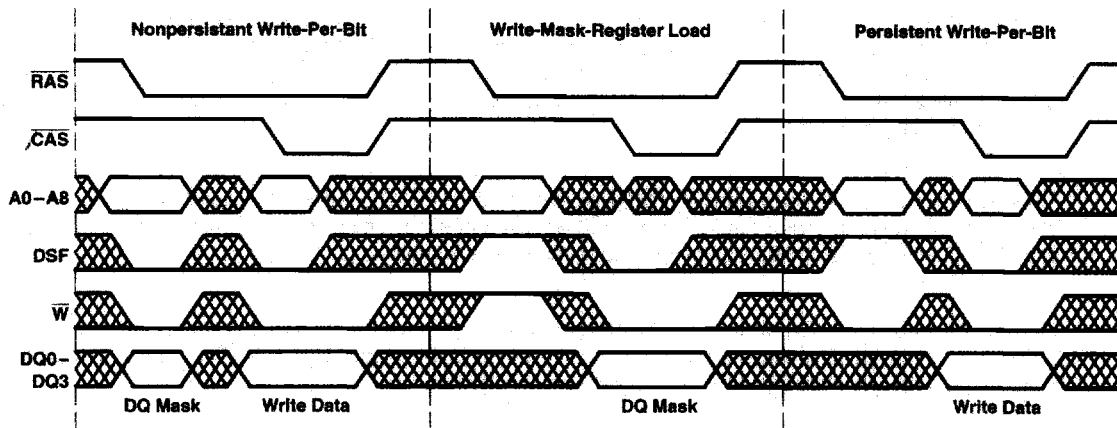

DQ Mask = H: Write to I/O enabled
 = L: Write to I/O disabled

Figure 1. Example of Write-Per-Bit Operations

block write

The block-write mode allows data (present in an on-chip color register) to be written into four consecutive column-address locations. The 4-bit color register is loaded by the color-register-load cycle. Both write-per-bit modes can be applied in the block-write cycle. The block-write mode also offers the 4 × 4 column-mask capability.

load color register

The load-color-register cycle is performed using normal DRAM write-cycle timing except that DSF is held high on the falling edges of RAS and CAS. A 4-bit code is input to the color register via the random I/O terminals and latched on the later of the falling edge of CAS or W. After the color register is loaded, it retains data until power is lost or until another load-color-register cycle is executed.

block write cycle

After the color register is loaded, the block-write cycle can begin as a normal DRAM write cycle with DSF held high on the falling edge of CAS (see Figures 2, 3, and 4). When the block-write cycle is invoked, each data bit in the 4-bit color register is written to selected bits of the four adjacent columns of the corresponding random I/O.

During block-write cycles, only the seven most significant column addresses (A2-A8) are latched on the falling edge of CAS. The two least significant addresses (A0-A1) are replaced by four DQ bits (DQ0-DQ3), which are also latched on the later of the falling edge of CAS or W. These four bits are used as a column mask, and they indicate which of the four column-address locations addressed by A2-A8 are written with the contents of the color register during the block-write cycle. DQ0 enables a write to column-address A1 = 0 (low), A0 = 0 (low); DQ1 enables a write to column-address A1 = 0 (low), A0 = 1 (high); DQ2 enables a write to column-address A1 = 1 (high), A0 = 0 (low); DQ3 enables a write to column-address A1 = 1 (high), A0 = 1 (high). A high logic level enables a write, and a low logic level disables the write. A maximum of 16 bits (4 × 4) can be written to memory during each CAS cycle in the block-write mode.



block write cycle (continued)

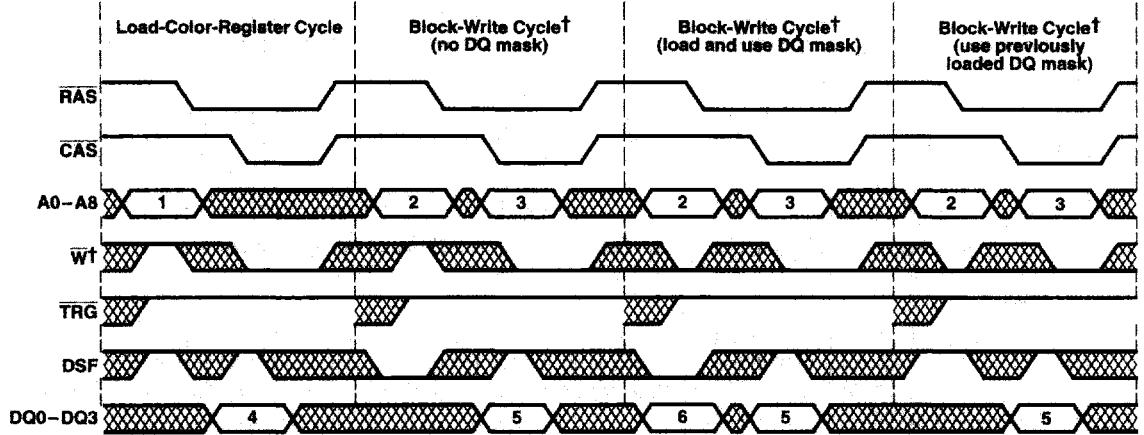

† \bar{W} must be low during the block-write cycle.

NOTE: DQ0-DQ3 are latched on the later of \bar{W} or \bar{CAS} falling edge except in block 6 (see legend).

Legend:

1. Refresh address
 2. Row address
 3. Block address (A2 - A8)
 4. Color-register data
 5. Column-mask data
 6. DQ-mask data. DQ0-DQ3 are latched on the falling edge of \bar{RAS} .
- = don't care

Figure 2. Example Block-Write Diagram Operations

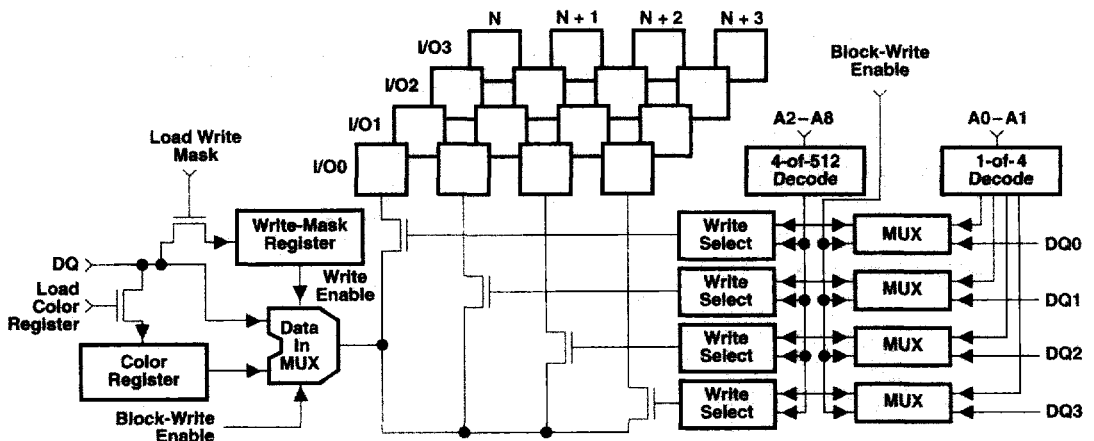

Figure 3. Block-Write Circuit Block Diagram

SMJ44C251B
262144 BY 4-BIT
MULTI-PORT VIDEO RAM

SGMS058A - MARCH 1995 - REVISED JUNE 1995

block write cycle (continued)

	DQ MASK	COLUMN MASK	COLOR REGISTER DATA		COLUMN 1	COLUMN 2	COLUMN 3	COLUMN 4
DQ0	1	0	0	Block Write →	Masked	0	0	0
DQ1	1	1	0		Masked	0	0	0
DQ2	0	1	1		Masked	Masked	Masked	Masked
DQ3	1	1	1		Masked	1	1	1

Figure 4. Example of Block Write Operation With DQ Mask and Address Mask

transfer operation

Transfer operations between the memory arrays (DRAM) and the data registers (SAM) are invoked by bringing TRG low before RAS falls. The states of \bar{W} , \bar{SE} , and \bar{DSF} , which are also latched on the falling edge of RAS, determine which transfer operation is invoked. Figure 5 shows an overview of data flow between the random and the serial interfaces.

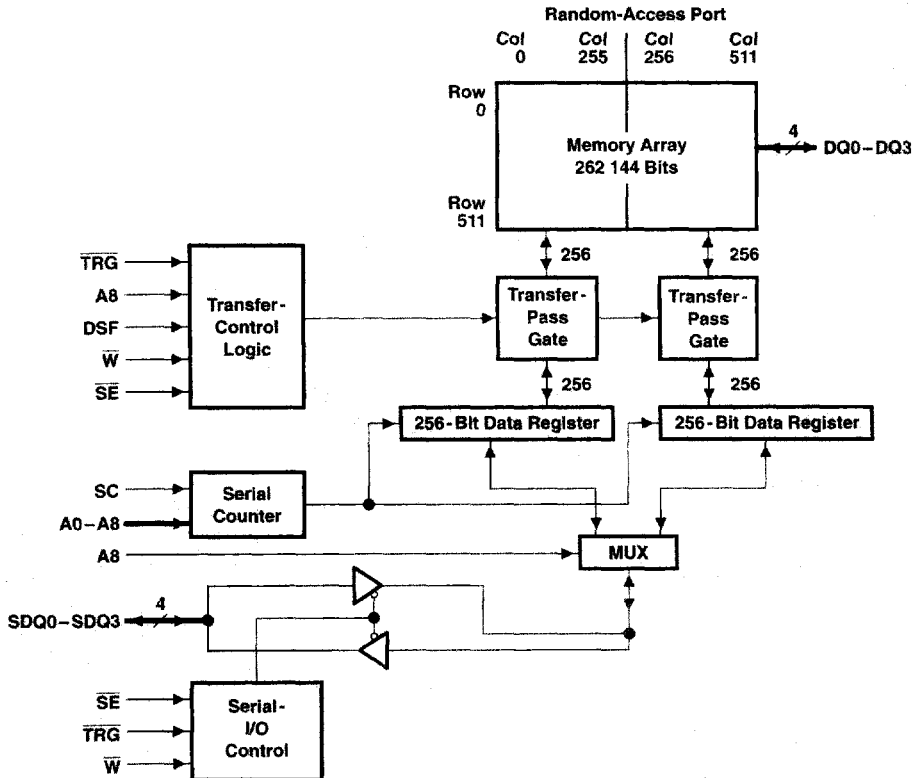

Figure 5. Block Diagram Showing One Random and One Serial-I/O Interface

transfer operation (continued)

As shown in Table 3, the SMJ44C251B supports five basic modes of transfer operation:

- Register-to-memory transfer (normal write transfer, SAM to DRAM)
- Alternate-write transfer (independent of the state of \overline{SE})
- Memory-to-register transfer (pseudo-transfer write). Switches serial port from serial-out mode to serial-in mode. No actual data transfer takes place between the DRAM and the SAM.
- Memory-to-register transfer (normal-read transfer, transfer entire contents of DRAM row to SAM)
- Split-register-read transfer (divides the SAM into a low and a high half. Only one half is transferred to the SAM while the other half is read from the serial I/O port.)

Table 3. Transfer-Operation Functions

FUNCTION	\overline{RAS} FALL					CAS FALL	ADDRESS		DQ0–DQ3	
	CAS	TRG	W	DSF	SE	DSF	\overline{RAS}	CAS	RAS	CAS W
Register-to-memory transfer (normal write transfer)	H	L	L	X	L	X	Row Addr	Tap Point	X	X
Alternate-write transfer (independent of SE)	H	L	L	H	X	X	Row Addr	Tap Point	X	X
Serial-write-mode enable (pseudo-transfer write)	H	L	L	L	H	X	Refresh Addr	Tap Point	X	X
Memory-to-register transfer (normal read transfer)	H	L	H	L	X	X	Row Addr	Tap Point	X	X
Split-register-read transfer (must reload tap)	H	L	H	H	X	X	Row Addr	Tap Point	X	X

Legend:

- H = High
- L = Low
- X = Don't care

write transfer

All write-transfer cycles (except the pseudo write transfer) transfer the entire content of SAM to the selected row in the DRAM. To invoke a write-transfer cycle, \overline{W} must be low when \overline{RAS} falls. There are three possible write-transfer operations: normal-write transfer, alternate-write transfer, and pseudo-write transfer.

All write-transfer cycles switch the serial port to the serial-in mode.

normal-write transfer (SAM-to-DRAM transfer)

A normal-write transfer cycle loads the contents of the serial-data register to a selected row in the memory array. \overline{TRG} , \overline{W} , and \overline{SE} are brought low and latched at the falling edge of \overline{RAS} . Nine row-address bits (A0–A8) are also latched at the falling edge of \overline{RAS} to select one of the 512 rows available as the destination of the data transfer. The nine column-address bits (A0–A8) are latched at the falling edge of \overline{CAS} to select one of the 512 tap points in SAM that are available for the next serial input.

During a write-transfer operation before \overline{RAS} falls, the serial-input operation must be suspended after a minimum delay of $t_{d(SCRL)}$ but can be resumed after a minimum delay of $t_{d(RHSC)}$ after \overline{RAS} goes high (see Figure 6).

normal-write transfer (SAM-to-DRAM transfer) (continued)

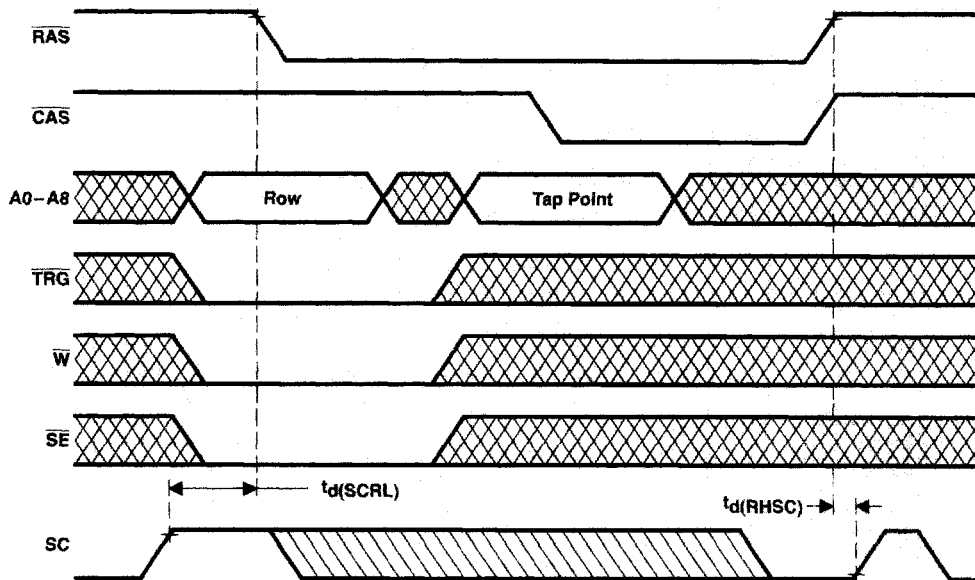

Figure 6. Normal-Write-Transfer-Cycle Timing

alternate-write transfer (refer to Figure 30)

When DSF is brought high and latched at the falling edge of $\overline{\text{RAS}}$ in the normal-write-transfer cycle, the alternate-write transfer occurs.

pseudo-write transfer (write-mode control) (refer to Figure 28)

To invoke the pseudo-write transfer (write-mode control cycle), $\overline{\text{SE}}$ is brought high and latched at the falling edge of $\overline{\text{RAS}}$. The pseudo-write transfer does not actually invoke any data transfer but switches the mode of the serial port from the serial-out (read) mode to the serial-in (write) mode.

Before serial data can be clocked into the serial port via the SDQ terminals and the SC input, the SDQ terminals must be switched into input mode. Because the transfer does not occur during the pseudo-transfer write, the row address (A0–A8) is in the don't care state and the column address (A0–A8), which is latched on the falling edge of $\overline{\text{CAS}}$, selects one of the 512 tap points in the SAM that are available for the next serial input.

read transfer (DRAM-to-SAM transfer) (refer to Figure 7)

During a read-transfer cycle, data from the selected row in DRAM is transferred to SAM. There are two read-transfer operations: normal-read transfer and split-register-read transfer.

normal-read transfer (refer to Figure 7)

The normal-read-transfer operation loads data from a selected row in DRAM into SAM. $\overline{\text{TRG}}$ is brought low and latched at the falling edge of $\overline{\text{RAS}}$. Nine row-address bits (A0–A8) are also latched at the falling edge of $\overline{\text{RAS}}$ to select one of the 512 rows available for transfer. The nine column-address bits (A0–A8) are latched at the falling edge of $\overline{\text{CAS}}$ to select one of the SAM's 512 available tap points where the serial data is read out.

A normal-read transfer can be performed in three ways: early-load read transfer, real-time or midline-load read transfer, and late-load read transfer. Each of these offers the flexibility of controlling the $\overline{\text{TRG}}$ trailing edge in the read-transfer cycle (see Figure 7).

normal-read transfer (continued)

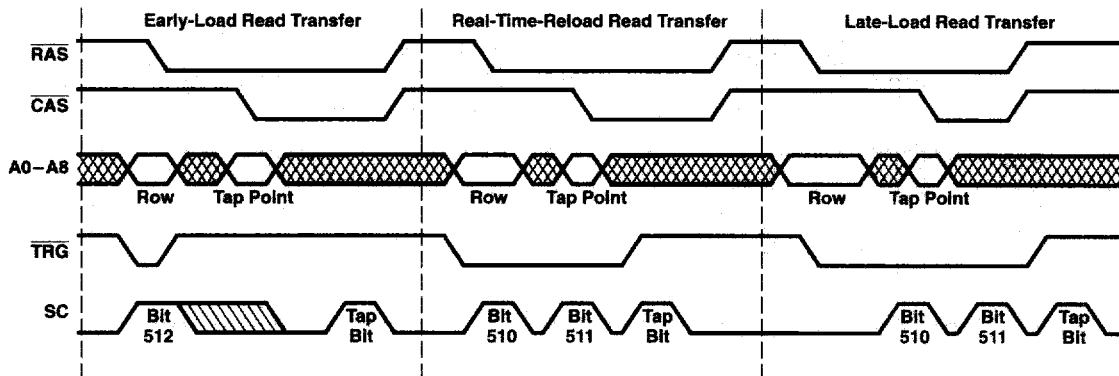

Figure 7. Normal-Read-Transfer Timings

split-register-read transfer

In split-register-read-transfer operation, the serial-data register is split into halves. The low half contains bits 0-255, and the high half contains bits 256-511. While one half is being read out of the SAM port, the other half can be loaded from the memory array.

To invoke a split-register read-transfer cycle, DSF is brought high, $\overline{\text{TRG}}$ is brought low, and both are latched at the falling edge of $\overline{\text{RAS}}$. Nine row-address bits (A0-A8) are also latched at the falling edge of $\overline{\text{RAS}}$ to select one of the 512 rows available for the transfer. The nine column-address bits (A0-A8) are latched at the falling edge of $\overline{\text{CAS}}$, where address bits A0-A7 select one of the 256 tap points in the specified half of SAM and address bit A8 selects which half is to be transferred. If A8 is a logic low, the low half is transferred. If A8 is a logic high, the high half is transferred. SAM locations 255 and 511 cannot be used as tap points.

A normal-read transfer must precede the split-register-read transfer to ensure proper operation. After the normal-read-transfer cycle, the first split-register read transfer can follow immediately without any minimum SC requirement. However, there is a minimum requirement of a rising edge of SC between split-register read-transfer cycles.

QSF indicates which half of the SAM is being accessed during serial-access operation. When QSF is low, the serial-address pointer is accessing the lower (least significant) 256 bits of the SAM. When QSF is high, the pointer is accessing the higher (most significant) 256 bits of the SAM. QSF changes state upon completing a normal-read-transfer cycle. The tap point loaded during the current transfer cycle determines the state of QSF. In split-register read-transfer mode, QSF changes state when a boundary between the two register halves is reached (see Figure 8 and Figure 9).

SMJ44C251B
262144 BY 4-BIT
MULTIPORT VIDEO RAM

SGMS058A - MARCH 1995 - REVISED JUNE 1995

split-register-read transfer (continued)

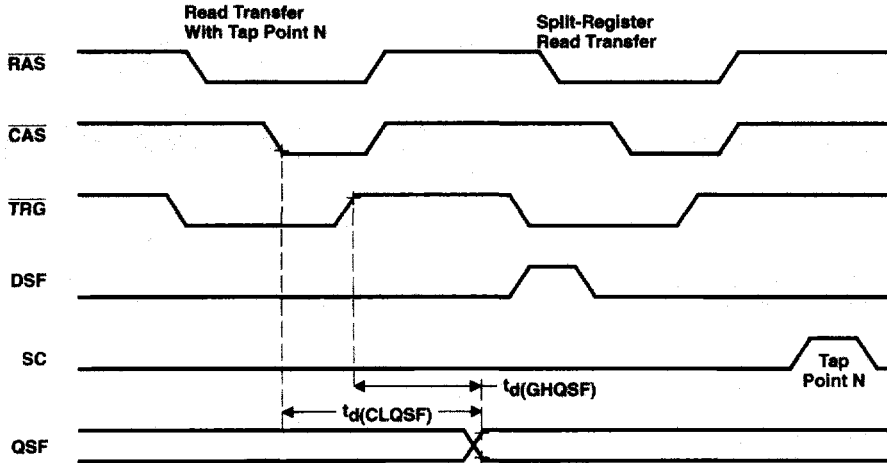

Figure 8. Example of a Split-Register Read-Transfer Cycle After a Normal Read-Transfer Cycle

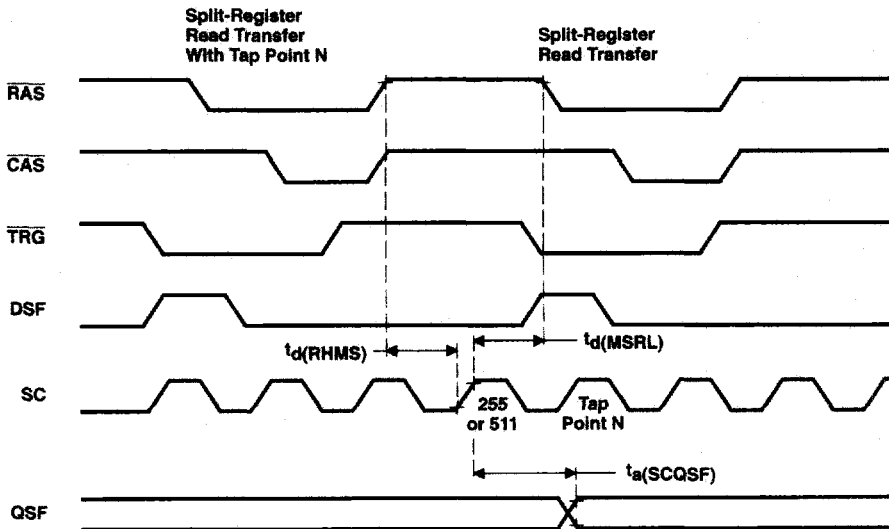

Figure 9. A Split-Register Read-Transfer Cycle After a Split-Register Read-Transfer Cycle

serial-access operation

The serial-read and serial-write operations can be performed through the SAM port simultaneously and asynchronously with DRAM operations except during transfer operations. The preceding transfer operation determines the input or output state of the SAM port. If the preceding transfer operation is a read-transfer operation, the SAM port is in the output mode. If the preceding transfer operation is a write- or pseudo-write-transfer operation, the SAM port is in the input mode.

Serial data can be read out of or written into SAM by clocking SC starting at the tap point loaded by the preceding transfer cycle, proceeding sequentially to the most significant bit (bit 511), then wrapping around to the least significant bit (bit 0) (see Figure 10).

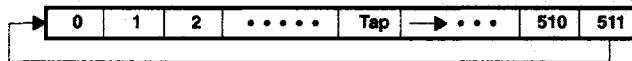

Figure 10. Serial Pointer Direction for Serial Read/Write

For split-register read-transfer operation, serial data can be read out from the active half of SAM by clocking SC starting at the tap point loaded by the preceding split-register-transfer cycle, then proceeding sequentially to the most significant bit of the half, bit 255 or bit 511. If there is a split-register-read transfer to the inactive half during this period, the serial pointer points next to the tap-point location loaded by that split register (see Figure 11, Case I). If there is no split-register read transfer to the inactive half during this period, the serial pointer points next to bit 256 or bit 0, respectively (see Figure 11, Case II).

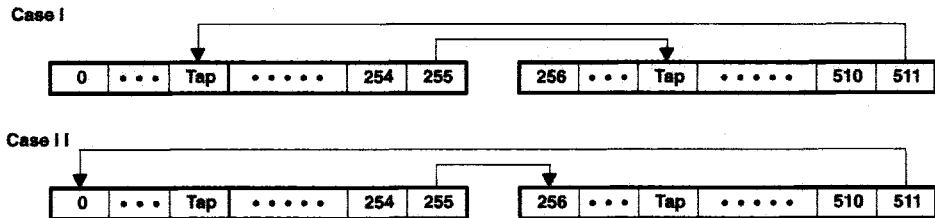

Figure 11. Serial Pointer for Split-Register Read

SMJ44C251B
262144 BY 4-BIT
MULTIPOINT VIDEO RAM

SGMS058A - MARCH 1995 - REVISED JUNE 1995

absolute maximum ratings over operating free-air temperature range (unless otherwise noted)†

Supply voltage range, V_{CC} (see Note 1)	-1 V to 7 V
Voltage range on any pin (see Note 1)	-1 V to 7 V
Short-circuit output current	50 mA
Power dissipation	1 W
Operating free-air temperature range, T_A : L suffix	0°C to 70°C
M suffix	-55°C to 125°C
Storage temperature range, T_{stg}	-65°C to 150°C

† Stresses beyond those listed under "absolute maximum ratings" may cause permanent damage to the device. These are stress ratings only, and functional operation of the device at these or any other conditions beyond those indicated under "recommended operating conditions" is not implied. Exposure to absolute-maximum-rated conditions for extended periods may affect device reliability.

NOTE 1: All voltage values are with respect to V_{SS} .

recommended operating conditions

		MIN	NOM	MAX	UNIT
V_{CC}	Supply voltage	4.5	5	5.5	V
V_{SS}	Supply voltage		0		V
V_{IH}	High-level input voltage	2.9		6.5	V
V_{IL}	Low-level input voltage (see Note Note 2)	-1		0.6	V
T_A	Operating free-air temperature	L suffix	0	70	°C
		M suffix	-55	125	
T_C	Operating case temperature	L suffix		70	°C
		M suffix		125	

NOTE 2: The algebraic convention, where the more negative (less positive) limit is designated as minimum, is used for logic-voltage levels only.



electrical characteristics over recommended ranges of supply voltage and operating free-air temperature (unless otherwise noted)

PARAMETER		TEST CONDITIONS	MIN	MAX	UNIT
V _{OH}	High-level output voltage	I _{OH} = -5 mA	2.4		V
V _{OL}	Low-level output voltage (see Note 3)	I _{OL} = 4.2 mA		0.4	V
I _I	Input leakage current	V _{CC} = 5 V, V _I = 0 V to 5.8 V, All others open		±10	μA
I _O	Output leakage current (see Note 4)	V _{CC} = 5.5 V, V _O = 0 V to V _{CC}		±10	μA

NOTES: 3. The SMJ44C251B may exhibit simultaneous switching noise as described in the Texas Instruments *Advanced CMOS Logic Designer's Handbook*. This phenomenon is exhibited on the DQ terminals when the SDQ terminals are switched and on the SDQ terminals when the DQ terminals are switched. This may cause V_{OL} and V_{OH} to exceed the data-book limit for a short period of time, depending upon output loading and temperature. Care should be taken to provide proper termination, decoupling, and layout of the device to minimize simultaneous switching effects.

4. SE is disabled for SDQ output leakage tests.

electrical characteristics over recommended ranges of supply voltage and operating free-air temperature (unless otherwise noted)

PARAMETER (SEE NOTE 5)	TEST CONDITIONS†	SAM PORT	'44C251B-10		'44C251B-12		UNIT
			MIN	MAX	MIN	MAX	
I _{CC1}	Operating current	t _{c(rd)} and t _{c(W)} = MIN	Standby		100	90	mA
I _{CC1A}	Operating current	t _{c(SC)} = MIN	Active		110	100	
I _{CC2}	Standby current	All clocks = V _{CC}	Standby		15	15	
I _{CC2A}	Standby current	t _{c(SC)} = MIN	Active		35	35	
I _{CC3}	RAS-only refresh current	t _{c(rd)} and t _{c(W)} = MIN	Standby		100	90	
I _{CC3A}	RAS-only refresh current	t _{c(SC)} = MIN	Active		110	100	
I _{CC4}	Page-mode current	t _{c(P)} = MIN	Standby		65	60	
I _{CC4A}	Page-mode current	t _{c(SC)} = MIN	Active		70	65	
I _{CC5}	CAS-before-RAS current	t _{c(rd)} and t _{c(W)} = MIN	Standby		90	80	
I _{CC5A}	CAS-before-RAS current	t _{c(SC)} = MIN	Active		110	100	
I _{CC6}	Data-transfer current	t _{c(rd)} and t _{c(W)} = MIN	Standby		100	90	
I _{CC6A}	Data-transfer current	t _{c(SC)} = MIN	Active		110	100	

† For conditions shown as MIN/MAX, use the appropriate value specified in the timing requirements.

NOTE 5: I_{CC} (standby) denotes that the SAM port is inactive (standby) and the DRAM port is active (except for I_{CC2}).

I_{CCA} (active) denotes that the SAM port is active and the DRAM port is active (except for I_{CC2}).

I_{CC} is measured with no load on DQ or SDQ.

SMJ44C251B
262144 BY 4-BIT
MULTIPOINT VIDEO RAM

SGMS058A - MARCH 1995 - REVISED JUNE 1995

capacitance over recommended ranges of supply voltage and operating free-air temperature, $f = 1$ MHz (see Note 6)

PARAMETER		MIN	MAX	UNIT
$C_i(A)$	Input capacitance, A0-A8		7	pF
$C_i(RC)$	Input capacitance, \overline{CAS} and \overline{RAS}		7	pF
$C_o(O)$	Output capacitance, SDQs and DQs		9	pF
$C_o(QSF)$	Output capacitance, QSF		9	pF

NOTE 6: Capacitance is sampled only at initial design and after any major change. Samples are tested at 0 V and 25°C with a 1-MHz signal applied to the terminal under test. All other terminals are open.

switching characteristics over recommended ranges of supply voltage and operating free-air temperature (see Note 7)

PARAMETER	TEST CONDITIONS †	ALT. SYMBOL	'44C251B-10		'44C251B-12		UNIT	
			MIN	MAX	MIN	MAX		
$t_a(C)$	Access time from \overline{CAS}	$t_d(RLCL) = \text{MAX}$	t_{CAC}	25		30	ns	
$t_a(CA)$	Access time from column address	$t_d(RLCL) = \text{MAX}$	t_{AA}	50		60	ns	
$t_a(CP)$	Access time from \overline{CAS} high	$t_d(RLCL) = \text{MAX}$	t_{CPA}	55		65	ns	
$t_a(R)$	Access time from \overline{RAS}	$t_d(RLCL) = \text{MAX}$	t_{RAC}	100		120	ns	
$t_a(G)$	Access time of DQ0-DQ3 from \overline{TRG} low		t_{OEA}	25		30	ns	
$t_a(SQ)$	Access time of SDQ0-SDQ3 from SC high	$C_L = 30$ pF	t_{SCA}	30		35	ns	
$t_a(SE)$	Access time of SDQ0-SDQ3 from \overline{SE} low	$C_L = 30$ pF	t_{SEA}	20		25	ns	
$t_{dis}(CH)$	Disable time, random output from \overline{CAS} high (see Note 8)	$C_L = 100$ pF	t_{OFF}	0	20	0	20	ns
$t_{dis}(G)$	Disable time, random output from \overline{TRG} high (see Note 8)	$C_L = 100$ pF	t_{OEZ}	0	20	0	20	ns
$t_{dis}(SE)$	Disable time, serial output from \overline{SE} high (see Note 8)	$C_L = 30$ pF	t_{SEZ}	0	20	0	20	ns

† For conditions shown as MIN/MAX, use the appropriate value specified in the timing requirements.

NOTES: 7. Switching times assume $C_L = 100$ pF unless otherwise noted (see Figure 12).

8. $t_{dis}(CH)$, $t_{dis}(G)$, and $t_{dis}(SE)$ are specified when the output is no longer driven.



timing requirements over recommended ranges of supply voltage and operating free-air temperature†

	ALT. SYMBOL	'44C251B-10		'44C251B-12		UNIT
		MIN	MAX	MIN	MAX	
$t_{c(rd)}$ Cycle time, read (see Note 9)	t_{RC}	190		220		ns
$t_{c(W)}$ Cycle time, write (see Note 9)	t_{WC}	190		220		ns
$t_{c(rdW)}$ Cycle time, read-modify-write (see Note 9)	t_{RMW}	250		290		ns
$t_{c(P)}$ Cycle time, page-mode read or write (see Note 9)	t_{PC}	60		70		ns
$t_{c(rdWP)}$ Cycle time, page-mode read-modify-write (see Note 9)	t_{PRMW}	105		125		ns
$t_{c(TRD)}$ Cycle time, read transfer (see Note 9)	t_{RC}	190		220		ns
$t_{c(TW)}$ Cycle time, write transfer (see Note 9)	t_{WC}	190		220		ns
$t_{c(SC)}$ Cycle time, serial clock (see Notes 9 and 10)	t_{SCC}	30		35		ns
$t_{w(CH)}$ Pulse duration, \overline{CAS} high	t_{CPN}	20		30		ns
$t_{w(CL)}$ Pulse duration, \overline{CAS} low (see Note 11)	t_{CAS}	25	75 000	30	75 000	ns
$t_{w(RH)}$ Pulse duration, \overline{RAS} high	t_{RP}	80		90		ns
$t_{w(RL)}$ Pulse duration, \overline{RAS} low (see Note 12)	t_{RAS}	100	75 000	120	75 000	ns
$t_{w(WL)}$ Pulse duration, \overline{W} low	t_{WP}	25		25		ns
$t_{w(TRG)}$ Pulse duration, \overline{TRG} low		25		30		ns
$t_{w(SCH)}$ Pulse duration, SC high	t_{SC}	10		12		ns
$t_{w(SCL)}$ Pulse duration, SC low	t_{SCP}	10		12		ns
$t_{w(SEL)}$ Pulse duration, \overline{SE} low	t_{SE}	35		40		ns
$t_{w(SEH)}$ Pulse duration, \overline{SE} high	t_{SEP}	35		40		ns
$t_{w(GH)}$ Pulse duration, \overline{TRG} high	t_{TP}	30		30		ns
$t_{w(RL)P}$ Pulse duration, \overline{RAS} low (page mode)		100	75 000	120	75 000	ns
$t_{su(CA)}$ Setup time, column address	t_{ASC}	0		0		ns
$t_{su(SFC)}$ Setup time, DSF before \overline{CAS} low	t_{FSC}	0		0		ns
$t_{su(RA)}$ Setup time, row address	t_{ASR}	0		0		ns
$t_{su(WMR)}$ Setup time, \overline{W} before \overline{RAS} low	t_{WSR}	0		0		ns
$t_{su(DQR)}$ Setup time, DQ before \overline{RAS} low	t_{MS}	0		0		ns
$t_{su(TRG)}$ Setup time, \overline{TRG} before \overline{RAS} low	t_{THS}	0		0		ns
$t_{su(SE)}$ Setup time, \overline{SE} before \overline{RAS} low (see Note 13)	t_{ESR}	0		0		ns
$t_{su(SESC)}$ Setup time, serial write disable	t_{SWIS}	10		15		ns
$t_{su(SFR)}$ Setup time, DSF before \overline{RAS} low	t_{FSR}	0		0		ns
$t_{su(DCL)}$ Setup time, data before \overline{CAS} low	t_{DSC}	0		0		ns
$t_{su(DWL)}$ Setup time, data before \overline{W} low	t_{DSW}	0		0		ns
$t_{su(rd)}$ Setup time, read command	t_{RCS}	0		0		ns
$t_{su(WCL)}$ Setup time, early write command before \overline{CAS} low	t_{WCS}	0		0		ns

† Timing measurements are referenced to V_{IL} max and V_{IH} min.

NOTES: 9. All cycle times assume $t_t = 5$ ns.

- When the odd tap is used (tap address can be 0-511, and odd taps are 1, 3, 5, etc.), the cycle time for SC in the first serial data out cycle needs to be 70 ns minimum.
- In a read-modify-write cycle, $t_d(CLWL)$ and $t_{su}(WCH)$ must be observed. Depending on the user's transition times, this may require additional \overline{CAS} low time $t_{w}(CL)$.
- In a read-modify-write cycle, $t_d(RLWL)$ and $t_{su}(WRH)$ must be observed. Depending on the user's transition times, this may require additional \overline{RAS} low time $t_{w}(RL)$.
- Register-to-memory (write) transfer cycles only

SMJ44C251B
262144 BY 4-BIT
MULTIPOINT VIDEO RAM

SGMS058A - MARCH 1985 - REVISED JUNE 1995

timing requirements over recommended ranges of supply voltage and operating free-air temperature (continued)†

	ALT. SYMBOL	'44C251B-10		'44C251B-12		UNIT
		MIN	MAX	MIN	MAX	
t _{su} (WCH) Setup time, write before $\overline{\text{CAS}}$ high	t _{CWL}	25		30		ns
t _{su} (WRH) Setup time, write before $\overline{\text{RAS}}$ high with $\overline{\text{TRG}} = \overline{\text{W}} = \text{low}$	t _{RWL}	25		30		ns
t _{su} (SDS) Setup time, SDQ before SC high	t _{SDS}	0		0		ns
t _h (CLCA) Hold time, column address after $\overline{\text{CAS}}$ low	t _{CAH}	20		20		ns
t _h (SFC) Hold time, DSF after $\overline{\text{CAS}}$ low	t _{CFH}	20		20		ns
t _h (RA) Hold time, row address after $\overline{\text{RAS}}$ low	t _{RAH}	15		15		ns
t _h (TRG) Hold time, $\overline{\text{TRG}}$ after $\overline{\text{RAS}}$ low	t _{TLH}	15		15		ns
t _h (SE) Hold time, $\overline{\text{SE}}$ after $\overline{\text{RAS}}$ low with $\overline{\text{TRG}} = \overline{\text{W}} = \text{low}$ (see Note 13)	t _{REH}	15		15		ns
t _h (RWM) Hold time, write mask, transfer enable after $\overline{\text{RAS}}$ low	t _{RWH}	15		15		ns
t _h (RDQ) Hold time, DQ after $\overline{\text{RAS}}$ low (write-mask operation)	t _{MH}	15		15		ns
t _h (SFR) Hold time, DSF after $\overline{\text{RAS}}$ low	t _{RFH}	15		15		ns
t _h (RLCA) Hold time, column address after $\overline{\text{RAS}}$ low (see Note 14)	t _{AR}	45		45		ns
t _h (CLD) Hold time, data after $\overline{\text{CAS}}$ low	t _{DH}	20		25		ns
t _h (RLD) Hold time, data after $\overline{\text{RAS}}$ low (see Note 14)	t _{DHR}	45		50		ns
t _h (WLD) Hold time, data after $\overline{\text{W}}$ low	t _{DH}	20		25		ns
t _h (CHrd) Hold time, read after $\overline{\text{CAS}}$ high (see Note 15)	t _{RCH}	0		0		ns
t _h (RHrd) Hold time, read after $\overline{\text{RAS}}$ high (see Note 15)	t _{RRH}	10		10		ns
t _h (CLW) Hold time, write after $\overline{\text{CAS}}$ low	t _{WCH}	30		35		ns
t _h (RLW) Hold time, write after $\overline{\text{RAS}}$ low (see Note 14)	t _{WCR}	50		55		ns
t _h (WLG) Hold time, $\overline{\text{TRG}}$ after $\overline{\text{W}}$ low (see Note 16)	t _{OEH}	25		30		ns
t _h (SDS) Hold time, SDQ after SC high	t _{SDH}	5		5		ns
t _h (SHSQ) Hold time, SDQ after SC high	t _{SOH}	5		5		ns
t _h (RSF) Hold time, DSF after $\overline{\text{RAS}}$ low	t _{FHR}	45		45		ns
t _h (SCSE) Hold time, serial-write disable	t _{SWIH}	20		20		ns
t _d (RLCH) Delay time, $\overline{\text{RAS}}$ low to $\overline{\text{CAS}}$ high	t _{CSH}	100		120		ns
t _d (CHRL) Delay time, $\overline{\text{CAS}}$ high to $\overline{\text{RAS}}$ low	t _{CRP}	0		0		ns
t _d (CLRH) Delay time, $\overline{\text{CAS}}$ low to $\overline{\text{RAS}}$ high	t _{RSH}	25		30		ns
t _d (CLWL) Delay time, $\overline{\text{CAS}}$ low to $\overline{\text{W}}$ low (see Notes 17 and 18)	t _{CWD}	55		65		ns
t _d (RLCL) Delay time, $\overline{\text{RAS}}$ low to $\overline{\text{CAS}}$ low (see Note 19)	t _{RCD}	25	75	25	90	ns
t _d (CARH) Delay time, column address to $\overline{\text{RAS}}$ high	t _{RAL}	50		60		ns
t _d (RLWL) Delay time, $\overline{\text{RAS}}$ low to $\overline{\text{W}}$ low (see Note 17)	t _{RWD}	130		155		ns
t _d (CAWL) Delay time, column address to $\overline{\text{W}}$ low (see Note 17)	t _{AWD}	85		100		ns

† Timing measurements are referenced to V_{IL} max and V_{IH} min.

NOTES: 13. Register-to-memory (write) transfer cycles only

14. The minimum value is measured when t_d(RLCL) is set to t_d(RLCL) min as a reference.
15. Either t_h(RHrd) or t_h(CHrd) must be satisfied for a read cycle.
16. Output-enable-controlled write. Output remains in the high-impedance state for the entire cycle.
17. Read-modify-write operation only
18. $\overline{\text{TRG}}$ must disable the output buffers prior to applying data to the DQ terminals.
19. The maximum value is specified only to assure $\overline{\text{RAS}}$ access time.



timing requirements over recommended ranges of supply voltage and operating free-air temperature (continued)[†]

	ALT. SYMBOL	'44C251B-10		'44C251B-12		UNIT
		MIN	MAX	MIN	MAX	
$t_d(\text{RLCH})_{\text{RF}}$ Delay time, $\overline{\text{RAS}}$ low to $\overline{\text{CAS}}$ high (see Note 20)	t_{CHR}	25		25		ns
$t_d(\text{CLRL})_{\text{RF}}$ Delay time, $\overline{\text{CAS}}$ low to $\overline{\text{RAS}}$ low (see Note 20)	t_{CSR}	10		10		ns
$t_d(\text{RHCL})_{\text{RF}}$ Delay time, $\overline{\text{RAS}}$ high to $\overline{\text{CAS}}$ low (see Note 20)	t_{RPC}	10		10		ns
$t_d(\text{CLGH})$ Delay time, $\overline{\text{CAS}}$ low to $\overline{\text{TRG}}$ high for DRAM read cycles		25		30		ns
$t_d(\text{GHD})$ Delay time, $\overline{\text{TRG}}$ high before data applied at DQ	t_{OED}	25		30		ns
$t_d(\text{RLTH})$ Delay time, $\overline{\text{RAS}}$ low to $\overline{\text{TRG}}$ high (real-time-reload read-transfer cycle only)	t_{RTH}	90		95		ns
$t_d(\text{RLSH})$ Delay time, $\overline{\text{RAS}}$ low to first SC high after $\overline{\text{TRG}}$ high (see Note 21)	t_{RSD}	130		140		ns
$t_d(\text{CLSH})$ Delay time, $\overline{\text{CAS}}$ low to first SC high after $\overline{\text{TRG}}$ high (see Note 21)	t_{CSD}	40		45		ns
$t_d(\text{SCTR})$ Delay time, SC high to $\overline{\text{TRG}}$ high (see Notes 21, 22, and 23)	t_{TSL}	15		20		ns
$t_d(\text{THRH})$ Delay time, $\overline{\text{TRG}}$ high to $\overline{\text{RAS}}$ high (see Notes 22 and 23)	t_{TRD}	-10		-10		ns
$t_d(\text{SCRL})$ Delay time, SC high to $\overline{\text{RAS}}$ low with $\overline{\text{TRG}} = \overline{\text{W}} = \text{low}$ (see Notes 13, 24, and 25)	t_{SRS}	10		20		ns
$t_d(\text{SCSE})$ Delay time, SC high to $\overline{\text{SE}}$ high in serial-input mode		20		20		ns
$t_d(\text{RHSC})$ Delay time, $\overline{\text{RAS}}$ high to SC high (see Note 13)	t_{SRD}	25		30		ns
$t_d(\text{THRL})$ Delay time, $\overline{\text{TRG}}$ high to $\overline{\text{RAS}}$ low (see Note 26)	t_{TRP}	$t_w(\text{RH})$		$t_w(\text{RH})$		ns
$t_d(\text{THSC})$ Delay time, $\overline{\text{TRG}}$ high to SC high (see Notes 22 and 23)	t_{TSD}	35		40		ns
$t_d(\text{SESC})$ Delay time, $\overline{\text{SE}}$ low to SC high (see Note 27)	t_{SWS}	10		15		ns
$t_d(\text{RHMS})$ Delay time, $\overline{\text{RAS}}$ high to last (most significant) rising edge of SC before boundary switch during split-register read-transfer cycles		15		20		ns
$t_d(\text{CLGH})$ Delay time, $\overline{\text{CAS}}$ low to $\overline{\text{TRG}}$ high in real-time read-transfer cycles	t_{CTH}	5		5		ns
$t_d(\text{CASH})$ Delay time, column address to first SC in early-load read-transfer cycles	t_{ASD}	45		50		ns
$t_d(\text{CAGH})$ Delay time, column address to $\overline{\text{TRG}}$ high in real-time read-transfer cycles	t_{ATH}	10		10		ns
$t_d(\text{RLCA})$ Delay time, $\overline{\text{RAS}}$ low to column address (see Note 19)	t_{RAD}	15	50	15	60	ns
$t_d(\text{DCL})$ Delay time, data to $\overline{\text{CAS}}$ low	t_{DZC}	0		0		ns
$t_d(\text{DGL})$ Delay time, data to $\overline{\text{TRG}}$ low	t_{DZO}	0		0		ns
$t_d(\text{RLSD})$ Delay time, $\overline{\text{RAS}}$ low to serial-input data	t_{SDD}	50		50		ns
$t_d(\text{GLRH})$ Delay time, $\overline{\text{TRG}}$ low to $\overline{\text{RAS}}$ high	t_{ROH}	25		30		ns

[†] Timing measurements are referenced to V_{IL} max and V_{IH} min.

- NOTES: 13. Register-to-memory (write) transfer cycles only
19. The maximum value is specified only to assure $\overline{\text{RAS}}$ access time.
20. $\overline{\text{CAS}}$ -before- $\overline{\text{RAS}}$ refresh operation only
21. Early-load read-transfer cycle only
22. Real-time-reload read-transfer cycle only
23. Late-load read-transfer cycle only
24. In a read-transfer cycle, the state of SC when $\overline{\text{RAS}}$ falls is a don't care condition. However, to assure proper sequencing of the internal clock circuitry, there can be no positive transitions of SC for at least 10 ns prior to when $\overline{\text{RAS}}$ goes low.
25. In a memory-to-register (read) transfer cycle, $t_d(\text{SCRL})$ applies only when the SAM was previously in serial-input mode.
26. Memory-to-register (read) and register-to-memory (write) transfer cycles only
27. Serial data-in cycles only

SMJ44C251B

262144 BY 4-BIT

MULTI-PORT VIDEO RAM

SGMS058A – MARCH 1995 – REVISED JUNE 1995

timing requirements over recommended ranges of supply voltage and operating free-air temperature (concluded)†

	ALT. SYMBOL	'44C251B-10		'44C251B-12		UNIT
		MIN	MAX	MIN	MAX	
t _d (MSRL) Delay time, last (most significant) rising edge of SC to RAS low before boundary switch during split-register read-transfer cycles		25		25		ns
t _d (SCQSF) Delay time, last (255 or 511) rising edge of SC to QSF switching at the boundary during split-register read-transfer cycles (see Note 7)	t _{SQD}		40		40	ns
t _d (CLQSF) Delay time, CAS low to QSF switching in read-transfer or write-transfer cycles (see Note 7)	t _{CQD}		35		35	ns
t _d (GHQSF) Delay time, TRG high to QSF switching in read-transfer or write-transfer cycles (see Note 7)	t _{TQD}		30		30	ns
t _d (RLQSF) Delay time, RAS low to QSF switching in read-transfer or write-transfer cycles (see Note 7)	t _{RQD}		75		75	ns
t _{rf} Refresh time interval, memory	t _{REF}		8		8	ms
t _t Transition time	t _T	3	50	3	50	ns

† Timing measurements are referenced to V_{IL} max and V_{IH} min.

NOTE 7: Switching times assume C_L = 100 pF unless otherwise noted (see Figure 12).

PARAMETER MEASUREMENT INFORMATION

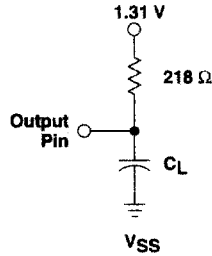

Figure 12. Load Circuit

PARAMETER MEASUREMENT INFORMATION

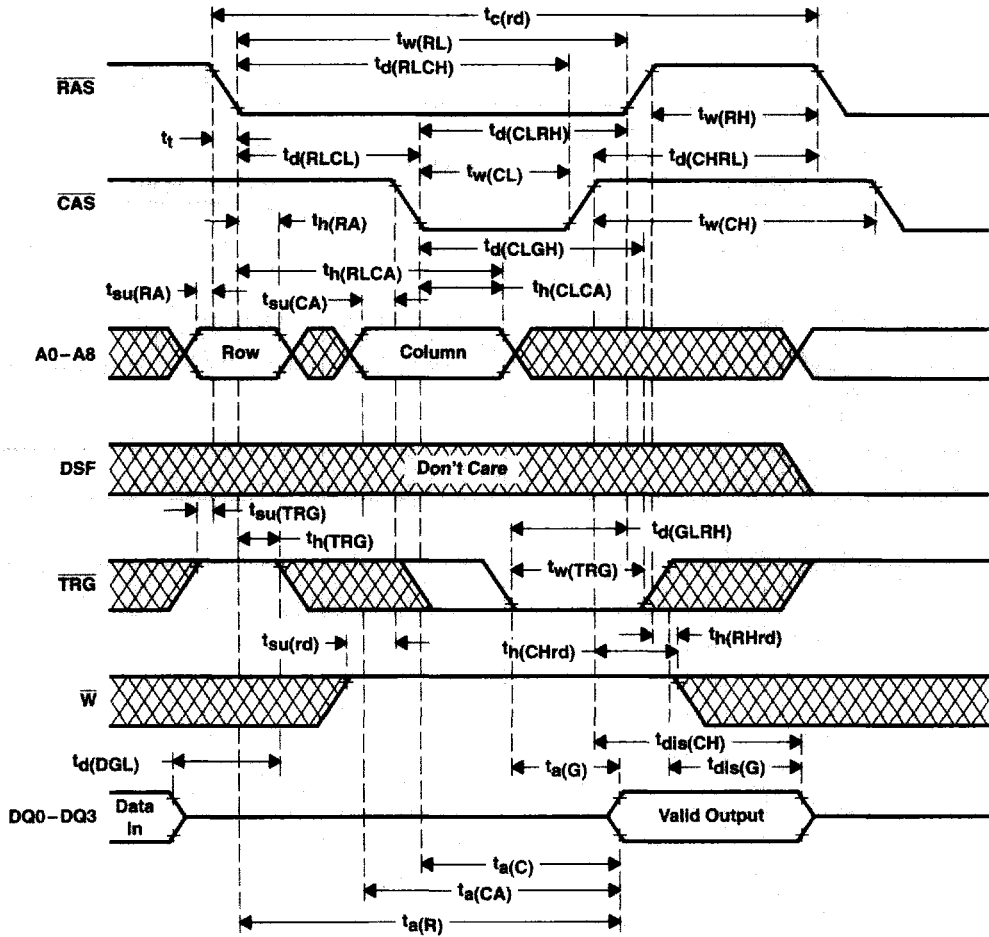

Figure 13. Read-Cycle Timing

PARAMETER MEASUREMENT INFORMATION

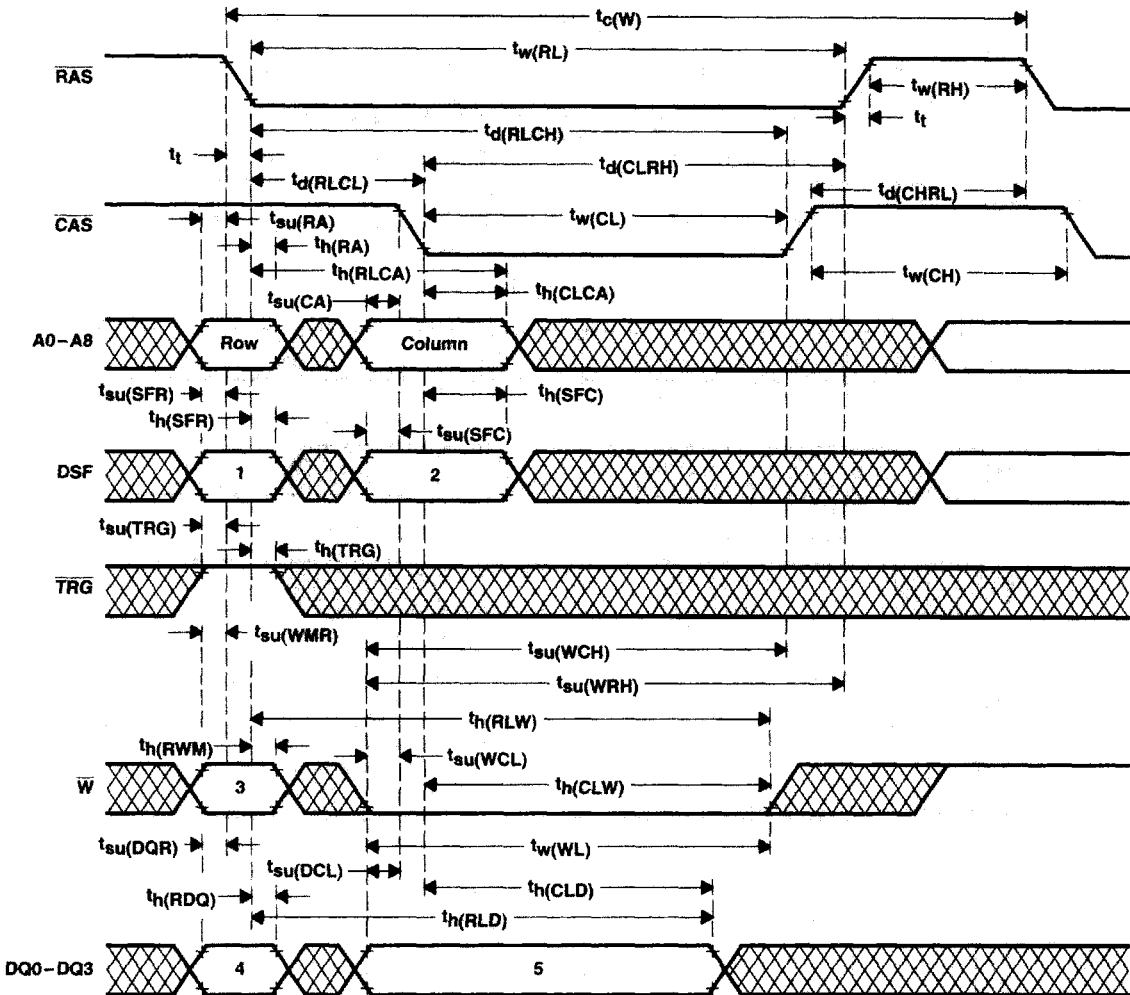

Figure 14. Early-Write-Cycle Timing

Table 4. Write-Cycle State Table

CYCLE	STATE				
	1	2	3	4	5
Write operation	L	L	H	Don't care	Valid data
Write-mask load/use, write DQs to I/Os	L	L	L	Write mask	Valid data
Use previous write mask, write DQs to I/Os	H	L	L	Don't care	Valid data
Load write mask on later of \bar{W} fall and \bar{CAS} fall	H	L	H	Don't care	Write mask

PARAMETER MEASUREMENT INFORMATION

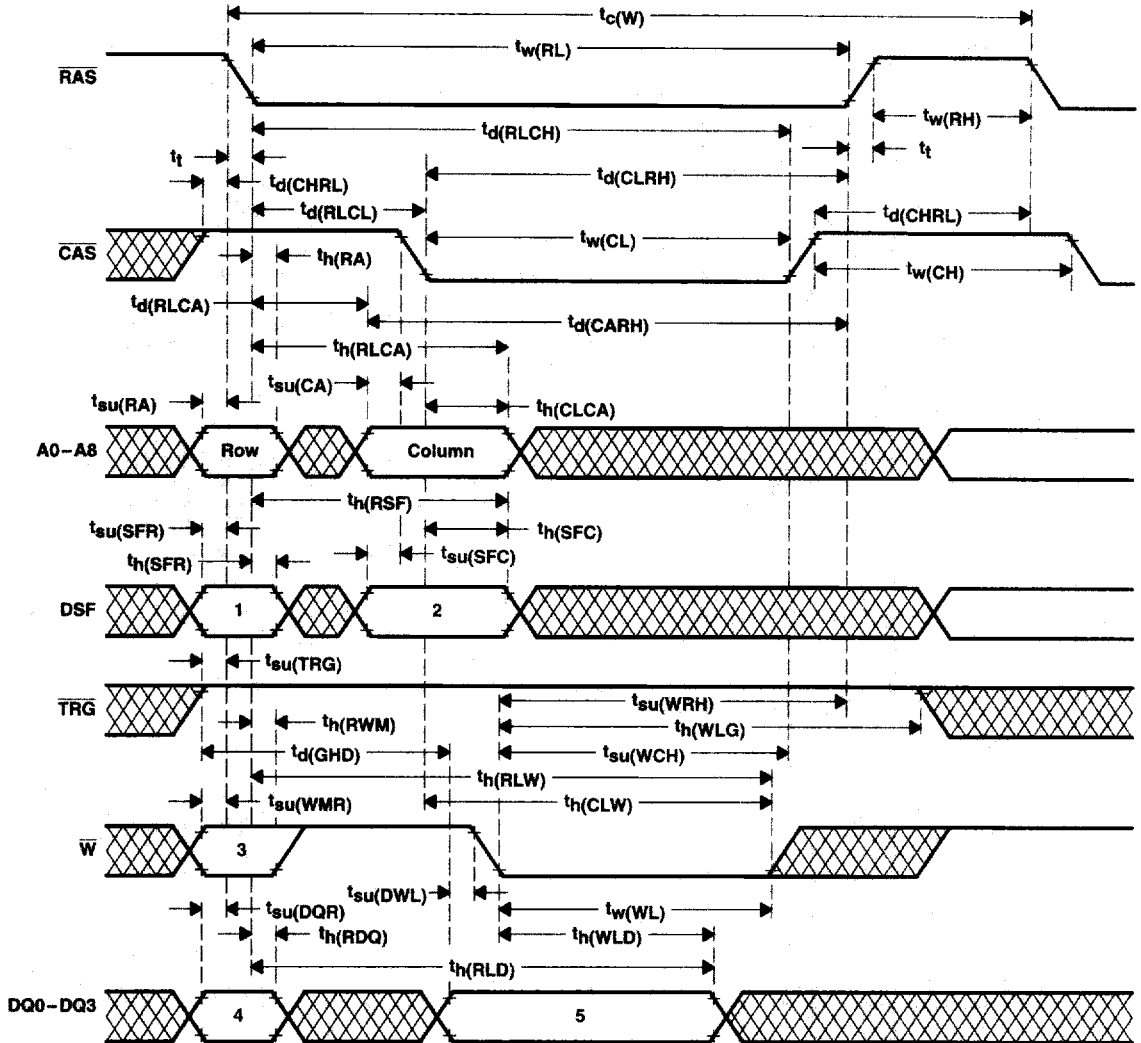

Figure 15. Delayed-Write-Cycle Timing (Output-Enable-Controlled Write)

Table 5. Write-Cycle State Table

CYCLE	STATE				
	1	2	3	4	5
Write operation	L	L	H	Don't care	Valid data
Write-mask load/use, write DQs to I/Os	L	L	L	Write mask	Valid data
Use previous write mask, write DQs to I/Os	H	L	L	Don't care	Valid data
Load write mask on later of \overline{W} fall and \overline{CAS} fall	H	L	H	Don't care	Write mask

PARAMETER MEASUREMENT INFORMATION

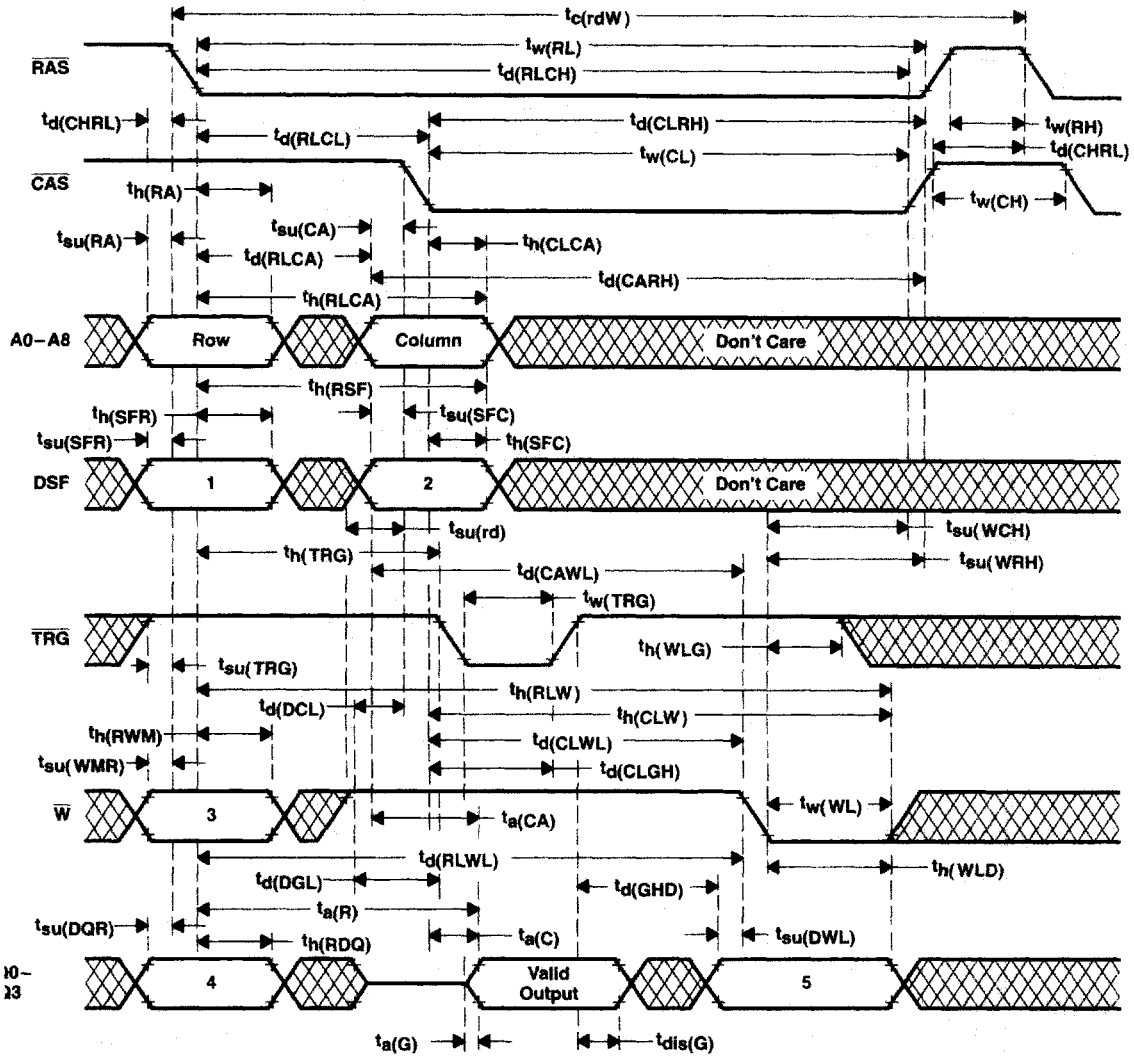
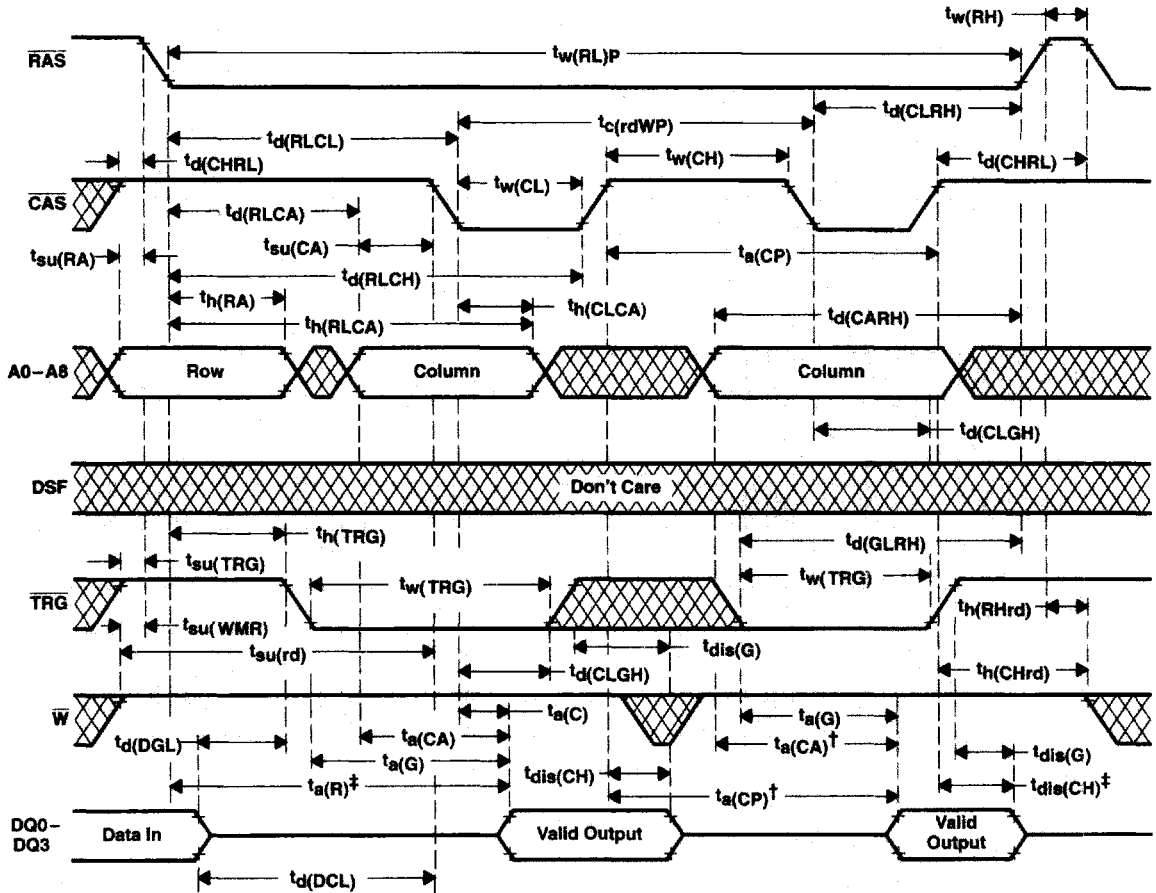

Figure 16. Read-Write/Read-Modify-Write-Cycle Timing

Table 6. Write-Cycle State Table

CYCLE	STATE				
	1	2	3	4	5
Write operation	L	L	H	Don't care	Valid data
Write-mask load/use, write DQs to I/Os	L	L	L	Write mask	Valid data
Use previous write mask, write DQs to I/Os	H	L	L	Don't care	Valid data
Load write mask on later of W fall and CAS fall	H	L	H	Don't care	Write mask

PARAMETER MEASUREMENT INFORMATION



† Access time is $t_a(CP)$ or $t_a(CA)$ dependent.

‡ Output can go from the high-impedance state to an invalid data state prior to the specified access time.

NOTE A: A write cycle or a read-modify-write cycle can be mixed with the read cycles as long as the write and read-modify-write timing specifications are not violated and the proper polarity of DSF is selected on the falling edges of \overline{RAS} and \overline{CAS} to select the desired write mode (normal, block write, etc.)

Figure 17. Enhanced-Page-Mode Read-Cycle Timing

PARAMETER MEASUREMENT INFORMATION

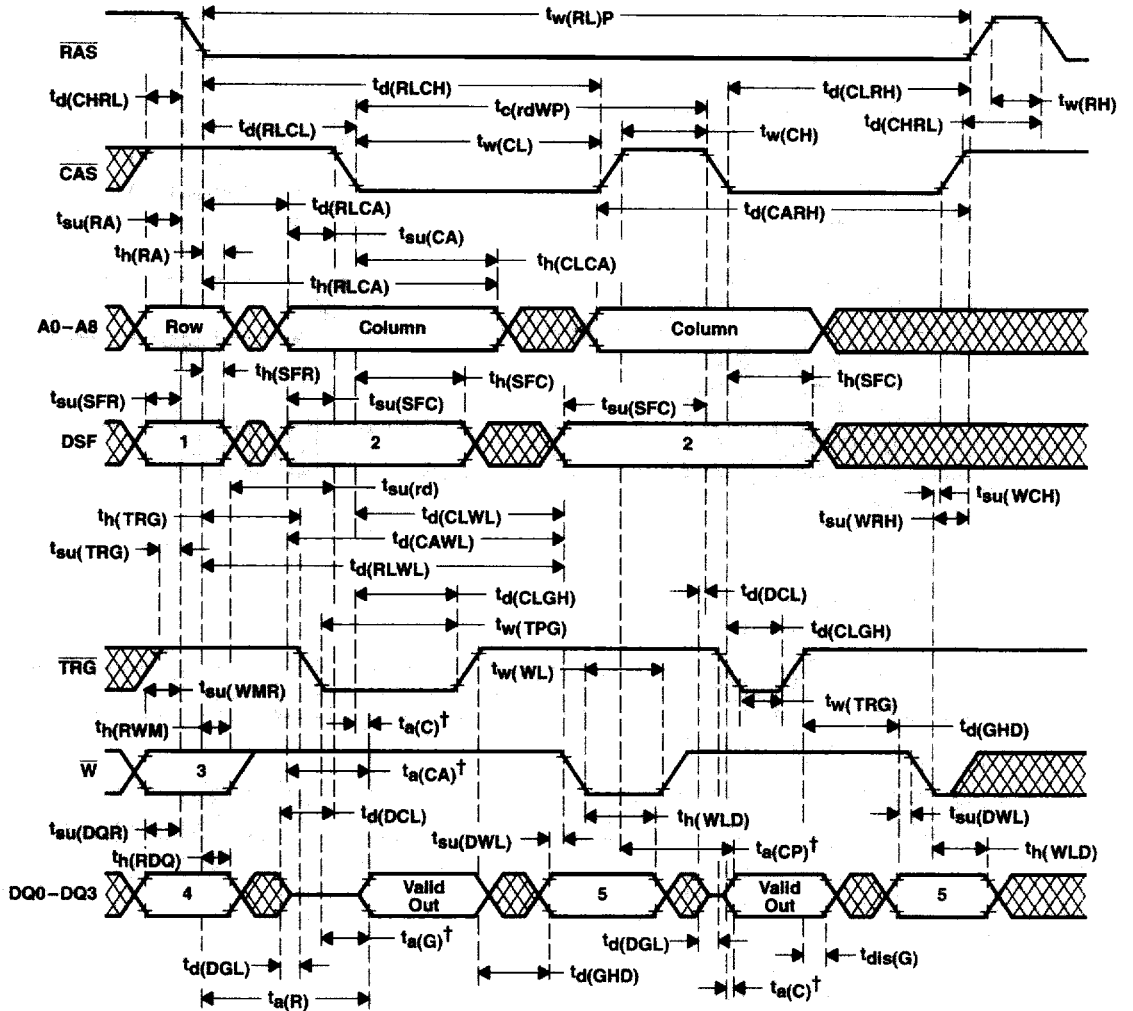

† Output can go from the high-impedance state to an invalid data state prior to the specified access time.

NOTE A: A read or a write cycle can be intermixed with read-modify-write cycles as long as the read and write timing specifications are not violated.

Figure 19. Enhanced-Page-Mode Read-Modify-Write Cycle Timing

Table 8. Write-Cycle State Table

CYCLE	STATE				
	1	2	3	4	5
Write operation	L	L	H	Don't care	Valid data
Write-mask load/use, write DQs to I/Os	L	L	L	Write mask	Valid data
Use previous write mask, write DQs to I/Os	H	L	L	Don't care	Valid data
Load write mask on later of \bar{W} fall and \bar{CAS} fall	H	L	H	Don't care	Write mask

SMJ44C251B
262144 BY 4-BIT
MULTI-PORT VIDEO RAM

SGMS058A - MARCH 1995 - REVISED JUNE 1995

PARAMETER MEASUREMENT INFORMATION

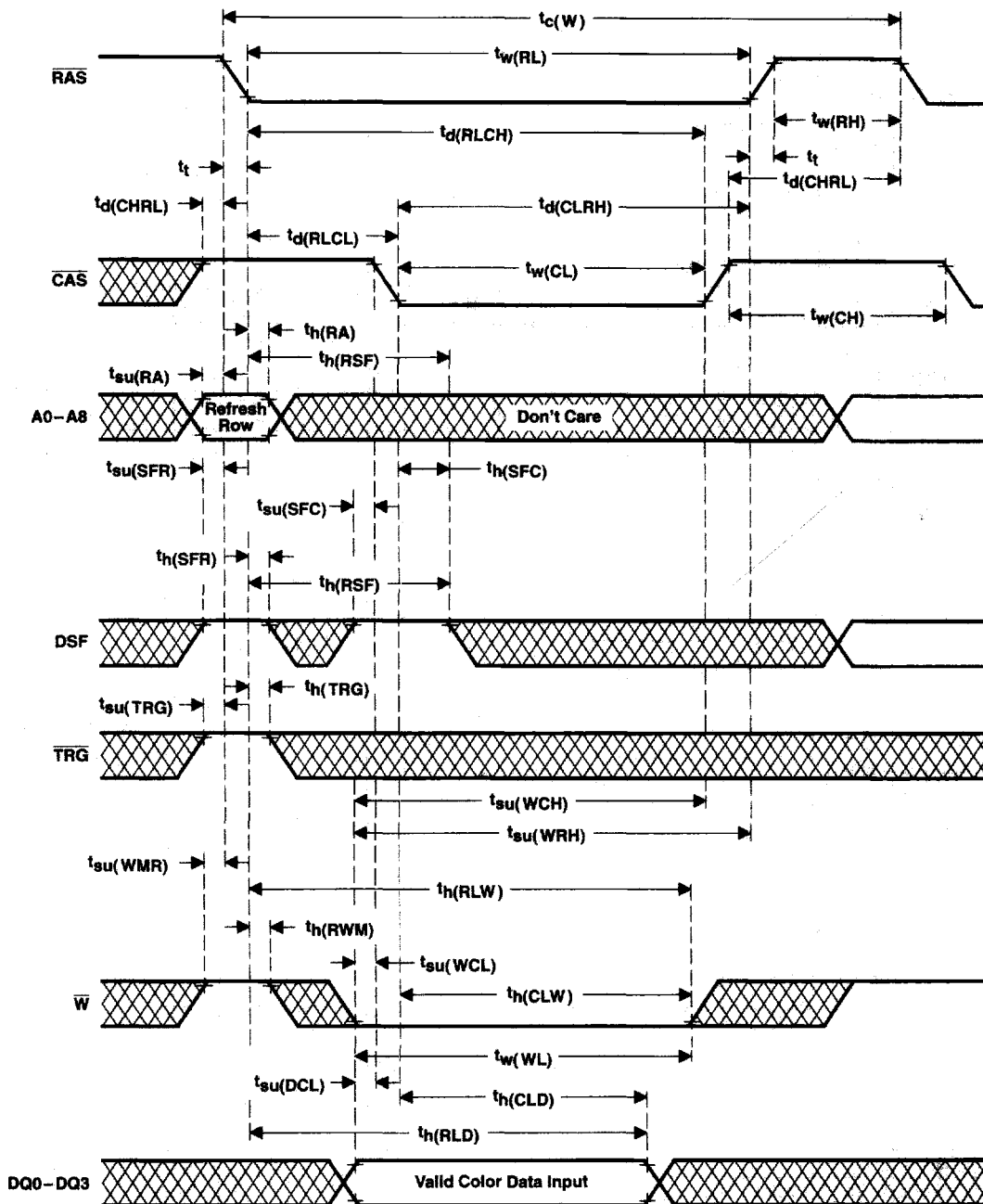

Figure 20. Load-Color-Register-Cycle Timing (Early-Write Load)



PARAMETER MEASUREMENT INFORMATION

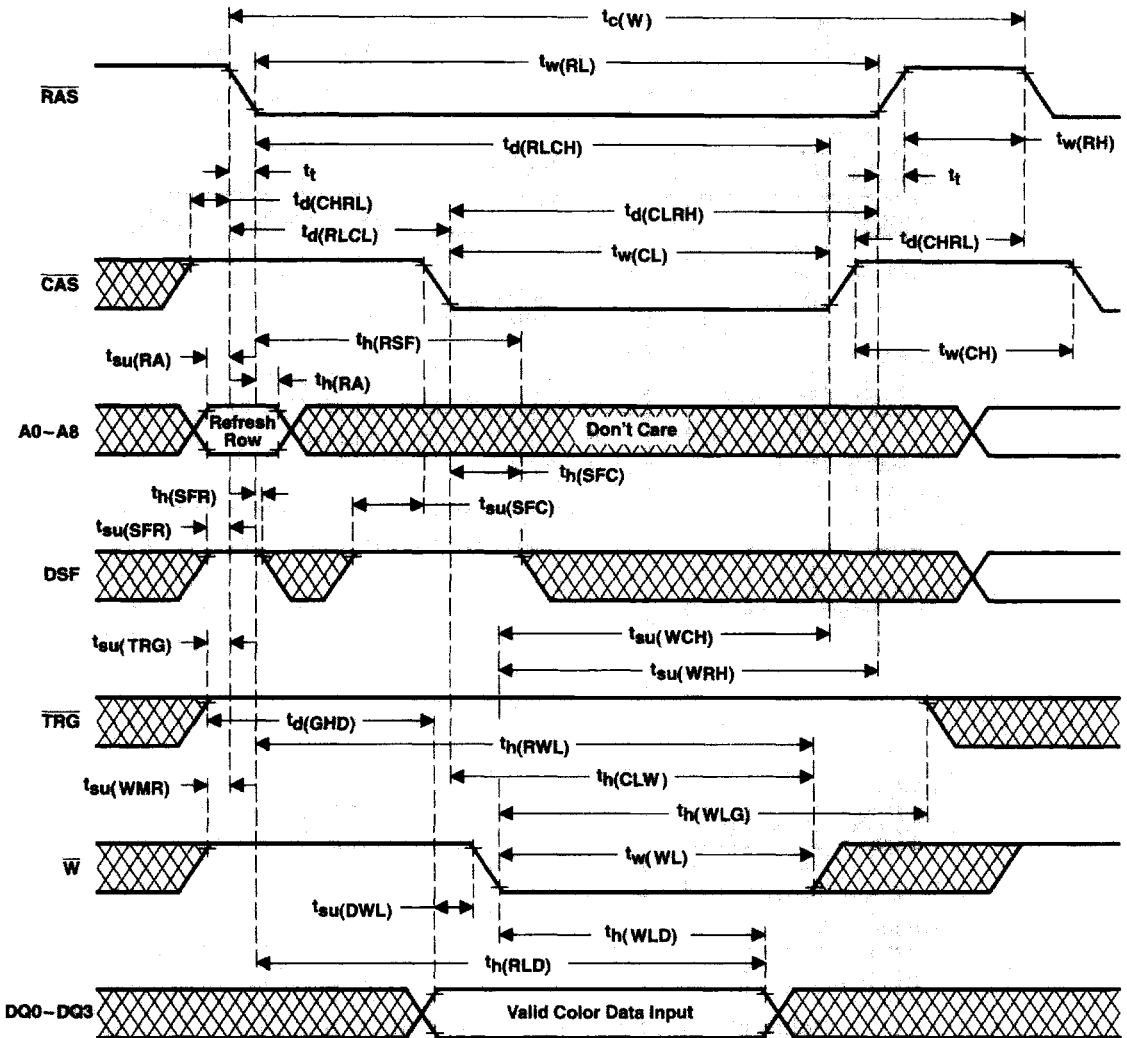

Figure 21. Load-Color-Register-Cycle Timing (Delayed-Write Load)

SMJ44C251B
262144 BY 4-BIT
MULTIPOINT VIDEO RAM

SGMS058A - MARCH 1995 - REVISED JUNE 1995

PARAMETER MEASUREMENT INFORMATION

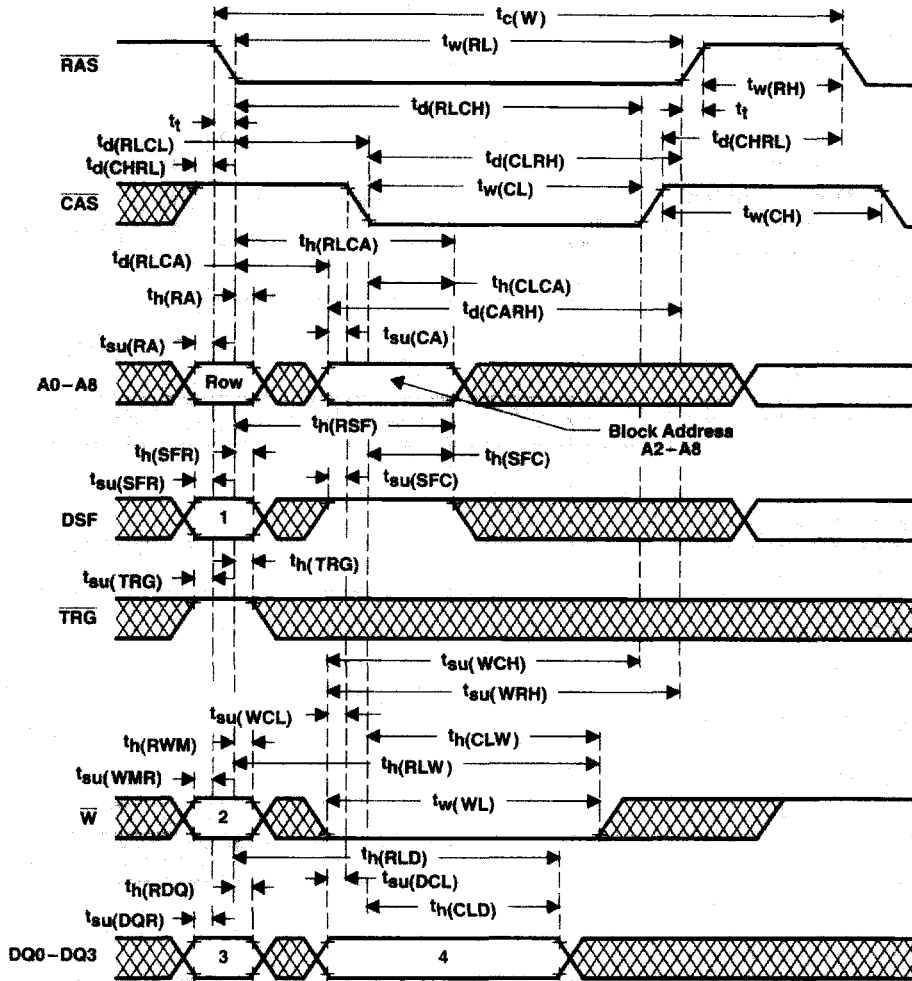

Figure 22. Block-Write-Cycle Timing (Early Write)

Table 9. Block-Write-Cycle State Table

CYCLE	STATE			
	1	2	3	4
Write-mask load/use, block write	L	L	Write mask	Column mask
Use previous write mask, block write	H	L	Don't care	Column mask
Write mask disabled, block write to all I/Os	L	H	Don't care	Column mask

Write mask data 0: I/O write disable
 1: I/O write enable

Column mask data DQn = 0 column write disable
 (n = 0, 1, 2, 3) 1 column write enable

DQ0 — column 0 (address A1 = 0, A0 = 0)
 DQ1 — column 1 (address A1 = 0, A0 = 1)
 DQ2 — column 2 (address A1 = 1, A0 = 0)
 DQ3 — column 3 (address A1 = 1, A0 = 1)



PARAMETER MEASUREMENT INFORMATION

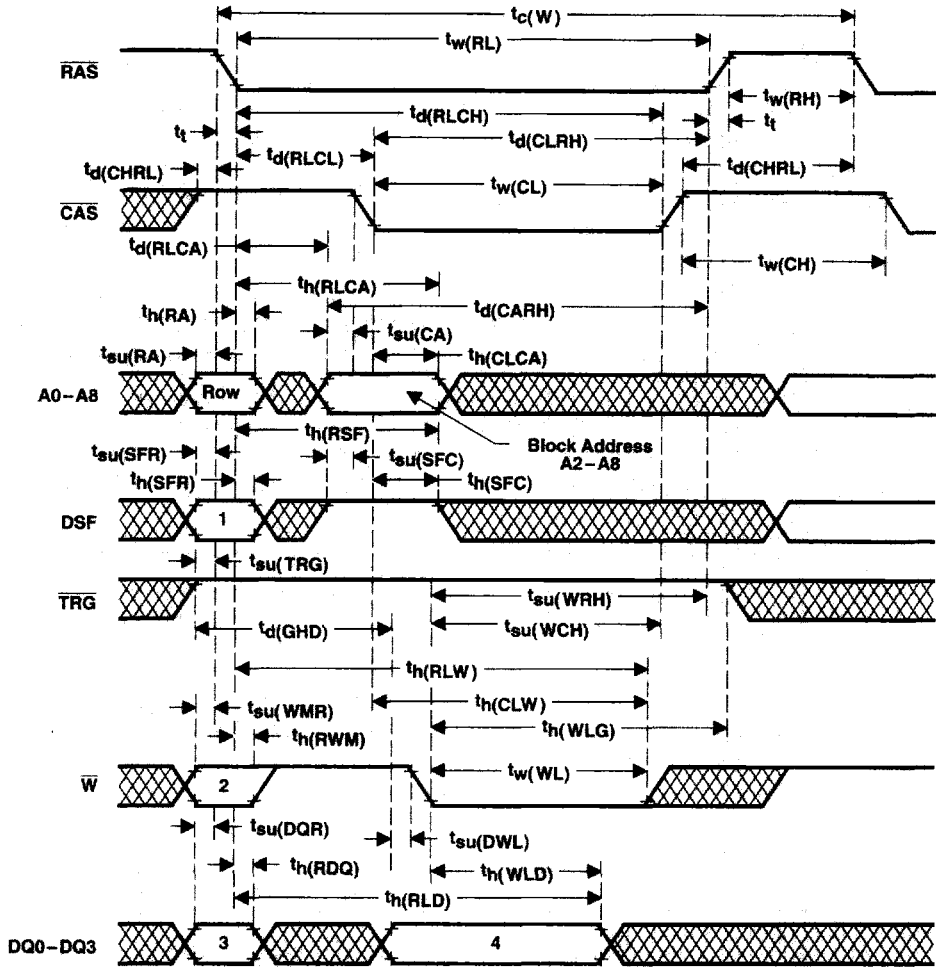

Figure 23. Block-Write-Cycle Timing (Delayed-Write)

Table 10. Block-Write-Cycle State Table

CYCLE	STATE			
	1	2	3	4
Write-mask load/use, block write	L	L	Write mask	Column mask
Use previous write mask, block write	H	L	Don't care	Column mask
Write mask disabled, block write to all I/Os	L	H	Don't care	Column mask

Write mask data 0: I/O write disable
1: I/O write enable

Column mask data DQn = 0 column write disable
(n = 0, 1, 2, 3) 1 column write enable

DQ0 — column 0 (address A1 = 0, A0 = 0)
DQ1 — column 1 (address A1 = 0, A0 = 1)
DQ2 — column 2 (address A1 = 1, A0 = 0)
DQ3 — column 3 (address A1 = 1, A0 = 1)

PARAMETER MEASUREMENT INFORMATION

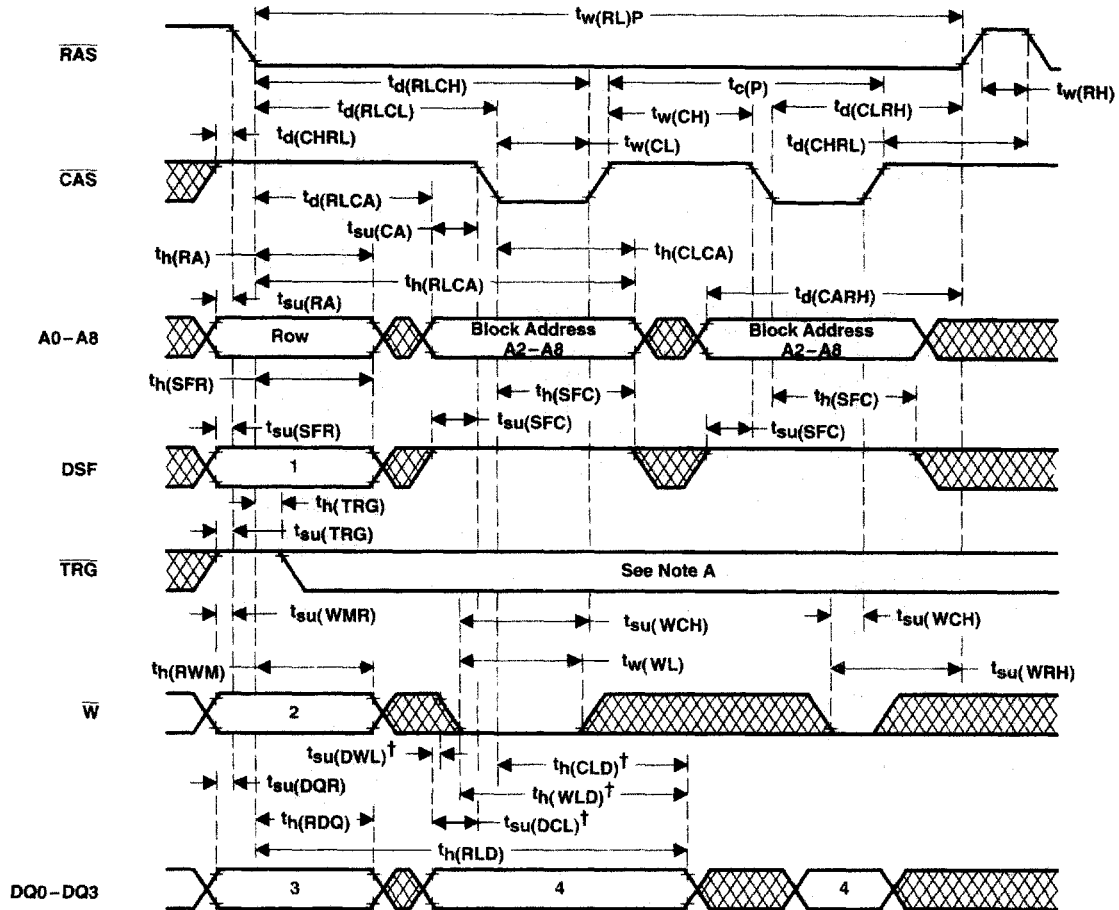

† Referenced to CAS or \bar{W} , whichever occurs last

NOTE A: TRG must remain high throughout the entire page-mode operation to assure page-mode cycle time if the late write feature is used. If the early-write-cycle timing is used, the state of TRG is a don't care after the minimum period $t_h(\text{TRG})$ from the falling edge of RAS.

Figure 24. Enhanced-Page-Mode Block-Write-Cycle Timing

Table 11. Enhanced-Page-Mode Block-Write-Cycle Table

CYCLE	STATE			
	1	2	3	4
Write-mask load/use, block write	L	L	Write mask	Column mask
Use previous write mask, block write	H	L	Don't care	Column mask
Write mask disabled, block write to all I/Os	L	H	Don't care	Column mask

Write mask data 0: I/O write disable
 1: I/O write enable

Column mask data DQn = 0 column write disable
 (n = 0, 1, 2, 3) 1 column write enable

DQ0 — column 0 (address A1 = 0, A0 = 0)
 DQ1 — column 1 (address A1 = 0, A0 = 1)
 DQ2 — column 2 (address A1 = 1, A0 = 0)
 DQ3 — column 3 (address A1 = 1, A0 = 1)

PARAMETER MEASUREMENT INFORMATION

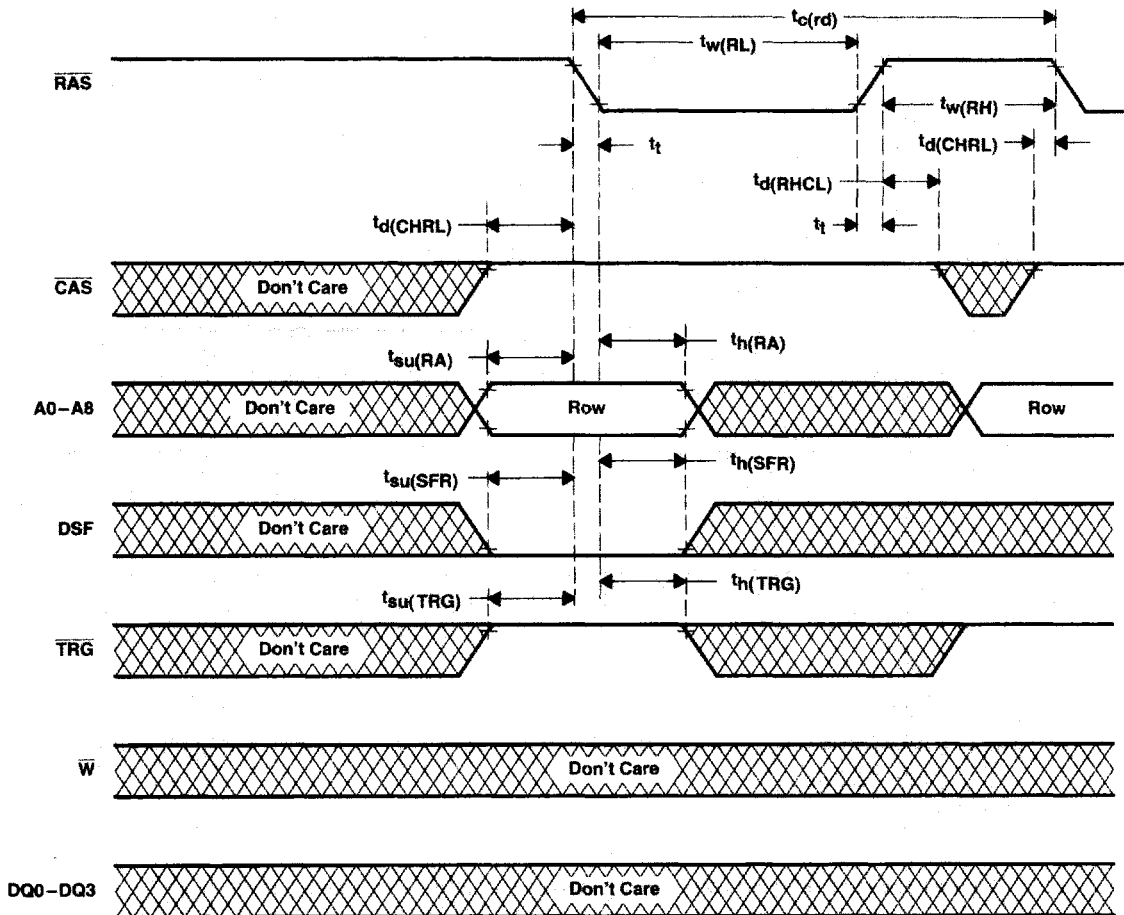

NOTE A: In persistent write-per-bit function, $\overline{\text{W}}$ must be high at the falling edge of $\overline{\text{RAS}}$ during the refresh cycle.

Figure 25. $\overline{\text{RAS}}$ -Only Refresh-Cycle Timing

SMJ44C251B
262144 BY 4-BIT
MULTIPORT VIDEO RAM

SGMS058A - MARCH 1995 - REVISED JUNE 1995

PARAMETER MEASUREMENT INFORMATION

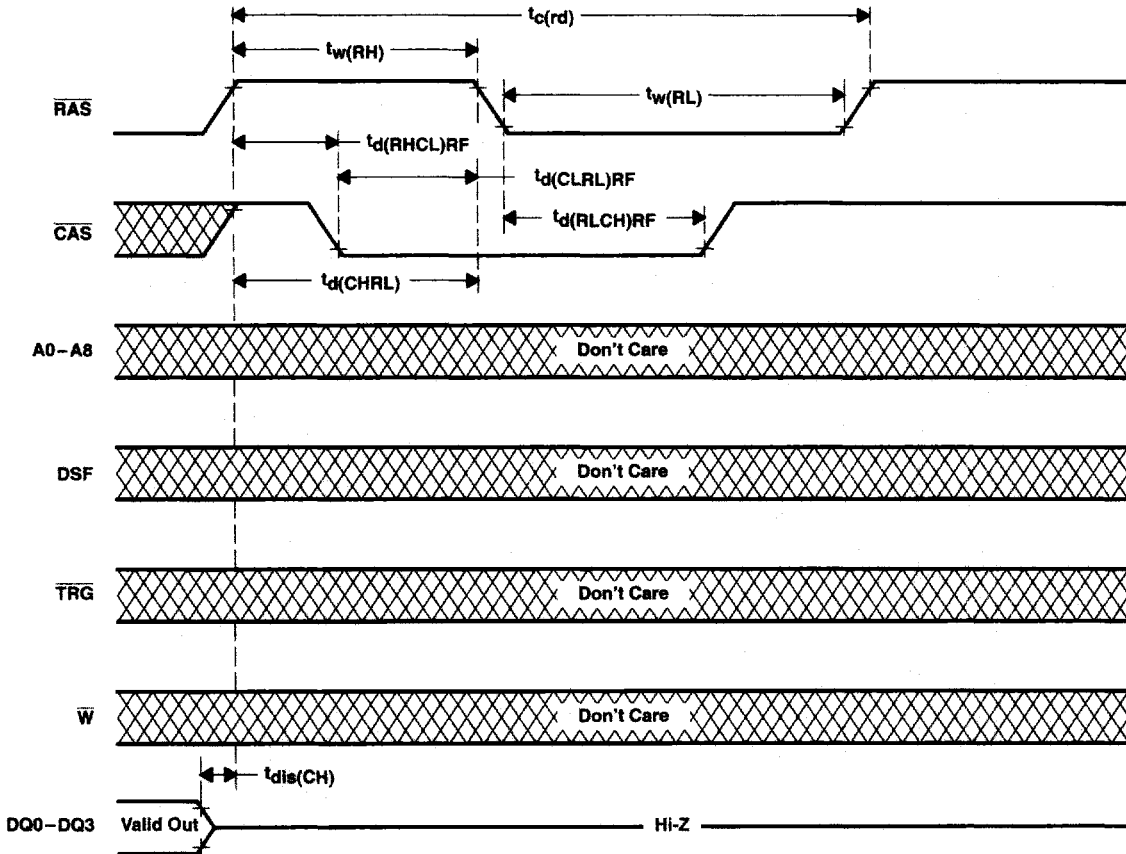

NOTE A: In persistent write-per-bit operation, \bar{W} must be high at the falling edge of \bar{RAS} during the refresh cycle.

Figure 26. CBR-Refresh-Cycle Timing

PARAMETER MEASUREMENT INFORMATION

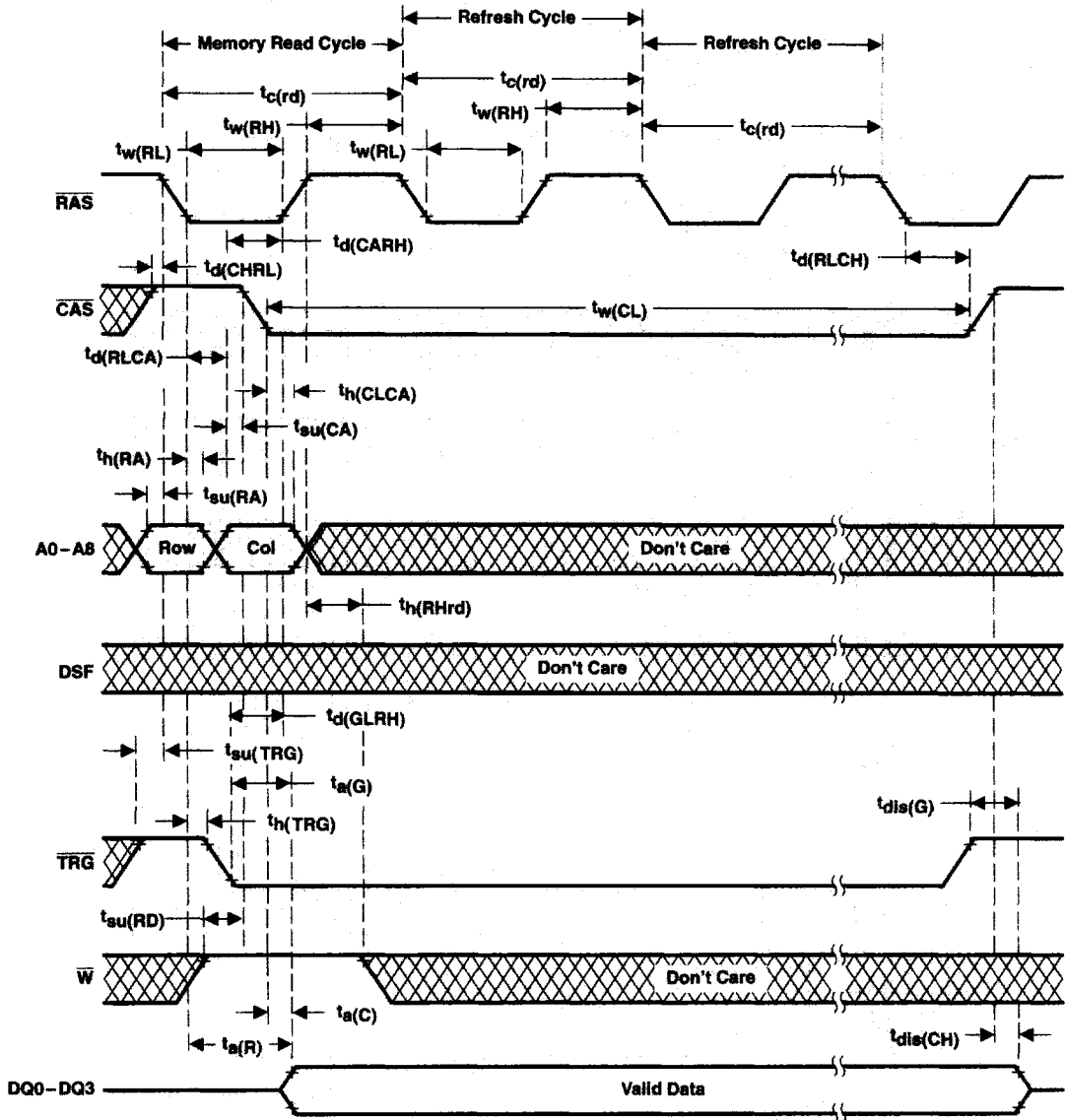
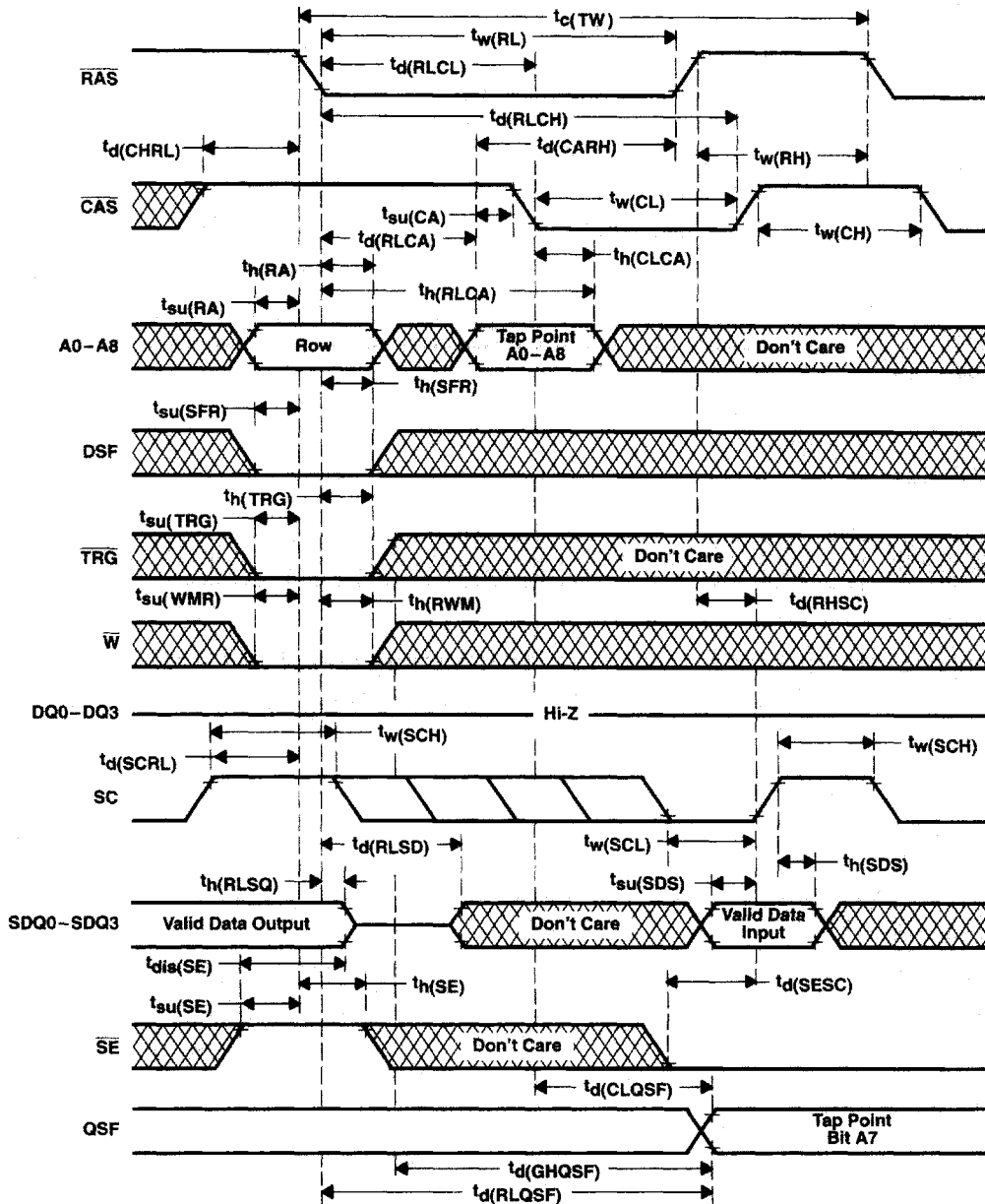

Figure 27. Hidden-Refresh-Cycle Timing

PARAMETER MEASUREMENT INFORMATION



NOTE: The write-mode-control cycle is used to change the SDQs from the output mode to the input mode. This allows serial data to be written into the data register. This figure assumes that the device was originally in the serial-read mode.

Figure 28. Write-Mode-Control Pseudo-Transfer Timing

PARAMETER MEASUREMENT INFORMATION

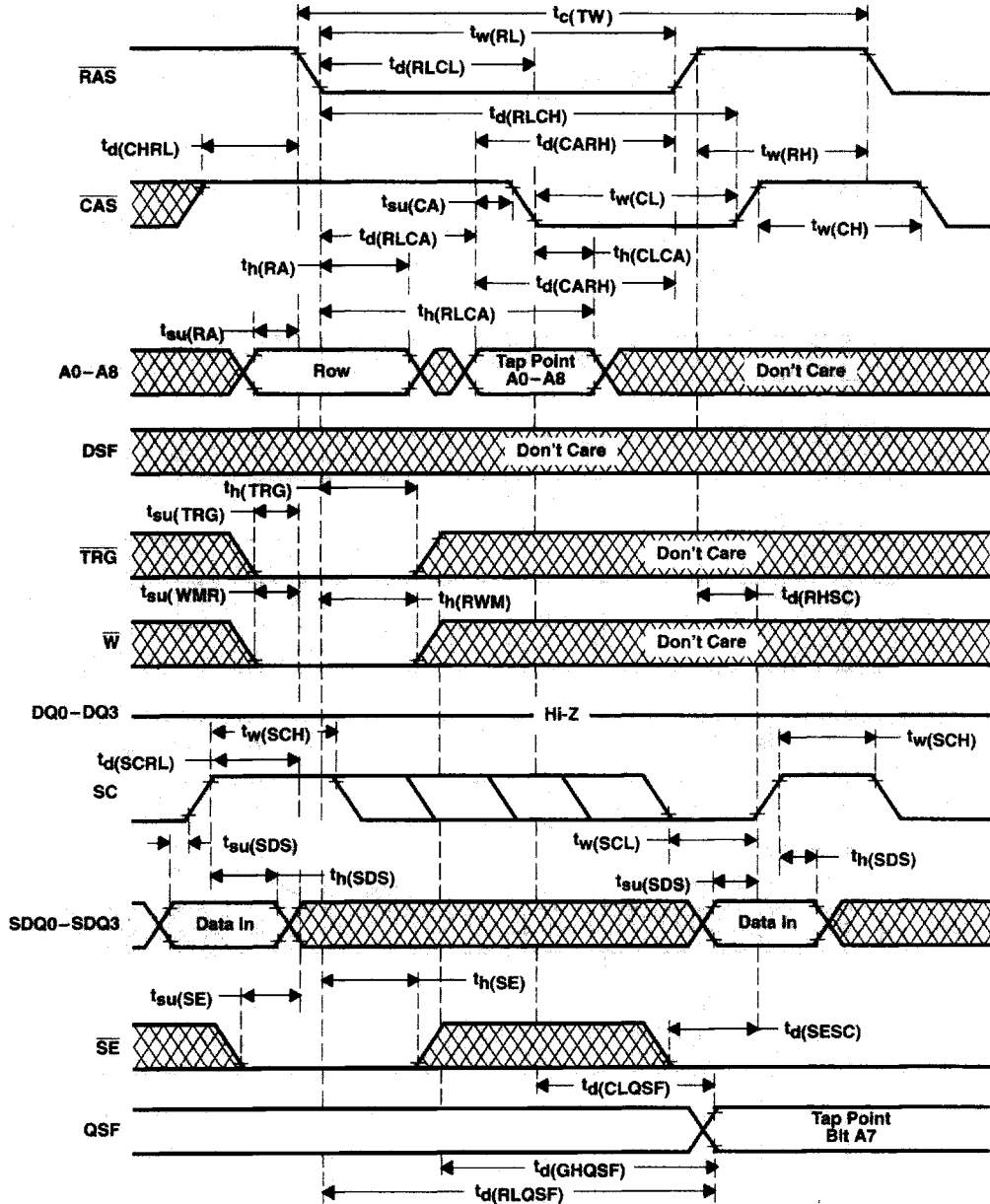

Figure 29. Data-Register-to-Memory Transfer Timing, Serial Input Enabled

SMJ44C251B
262144 BY 4-BIT
MULTI-PORT VIDEO RAM

SGMS058A - MARCH 1995 - REVISED JUNE 1995

PARAMETER MEASUREMENT INFORMATION

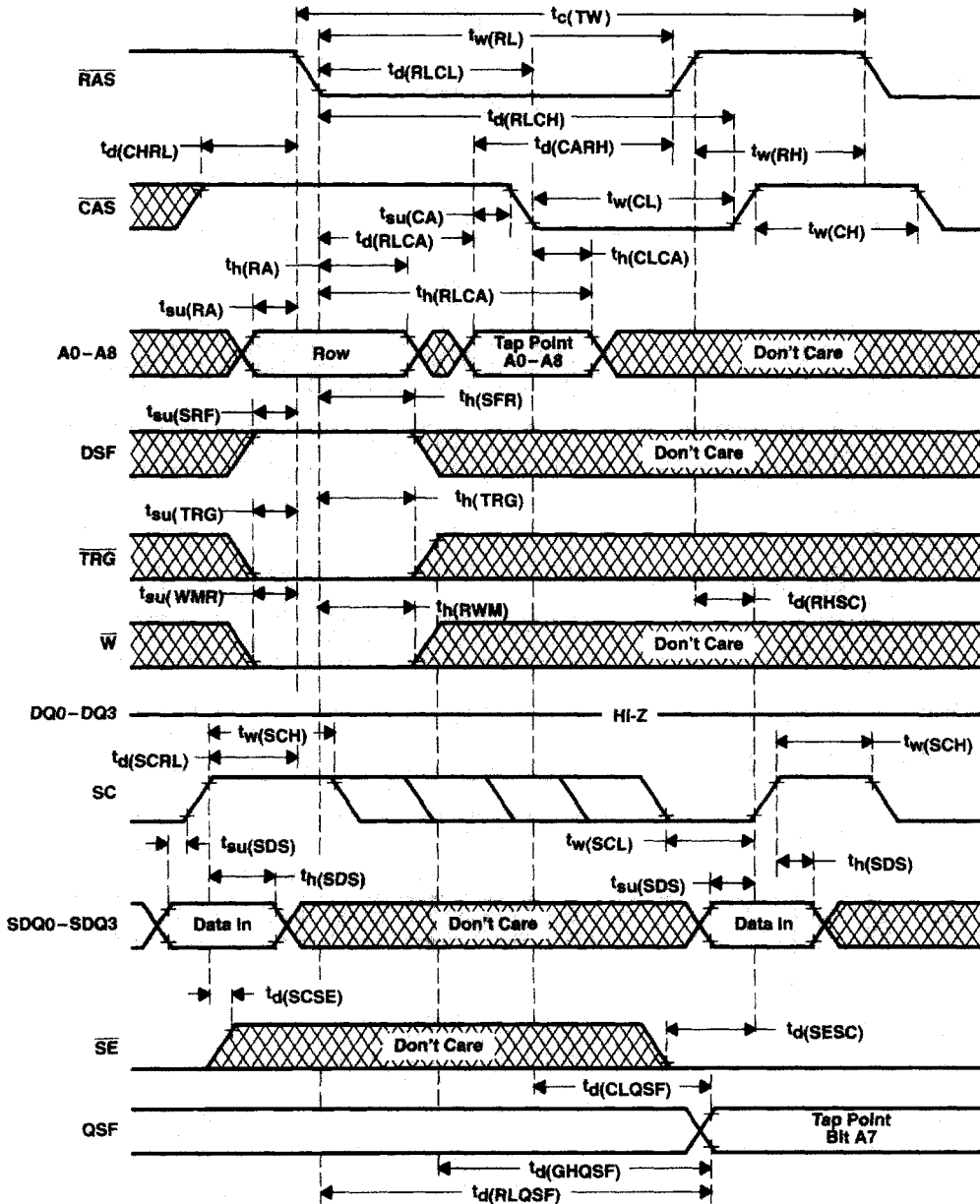
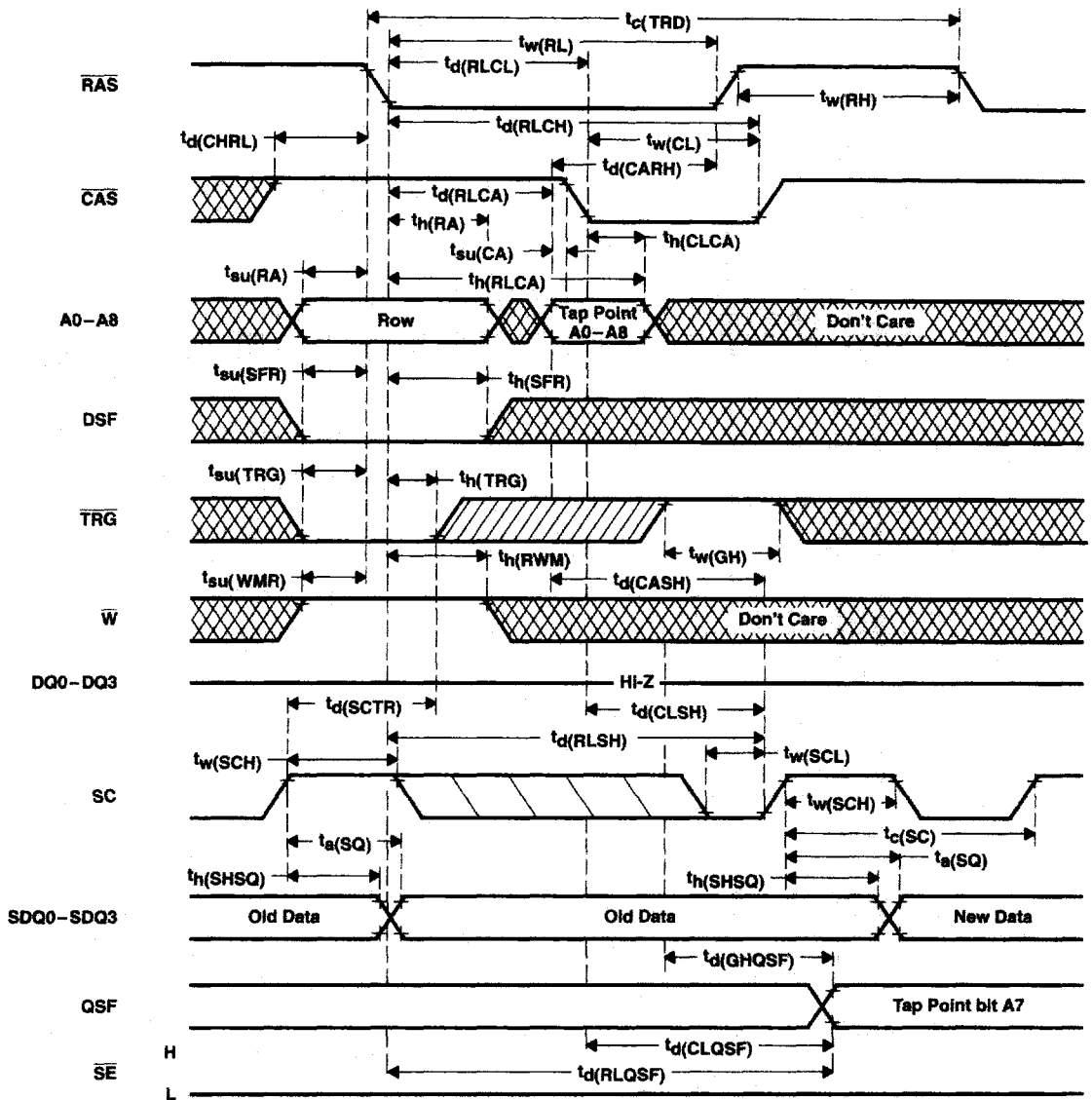

Figure 30. Alternate Data-Register-to-Memory Transfer-Cycle Timing

PARAMETER MEASUREMENT INFORMATION



- NOTES: A. Early-load operation is defined as $t_h(TRG)_{min} < t_h(TRG) < t_d(RLTH)_{min}$.
 B. DQ outputs remain in the high-impedance state for the entire memory-to-data-register transfer cycle. The memory-to-data-register transfer cycle is used to load the data registers in parallel from the memory array. The 512 locations in each data register are written from the 512 corresponding columns of the selected row. The data that is transferred into the data registers can be either shifted out or transferred back into another row.
 C. Once data is transferred into the data registers, the SAM is in the serial-read mode (i.e., SQ is enabled), allowing data to be shifted out of the registers. Also, the first bit to be read from the data register after TRG has gone high must be activated by a positive transition of SC.

Figure 31. Memory-to-Data-Register Transfer-Cycle Timing, Early-Load Operation

PARAMETER MEASUREMENT INFORMATION

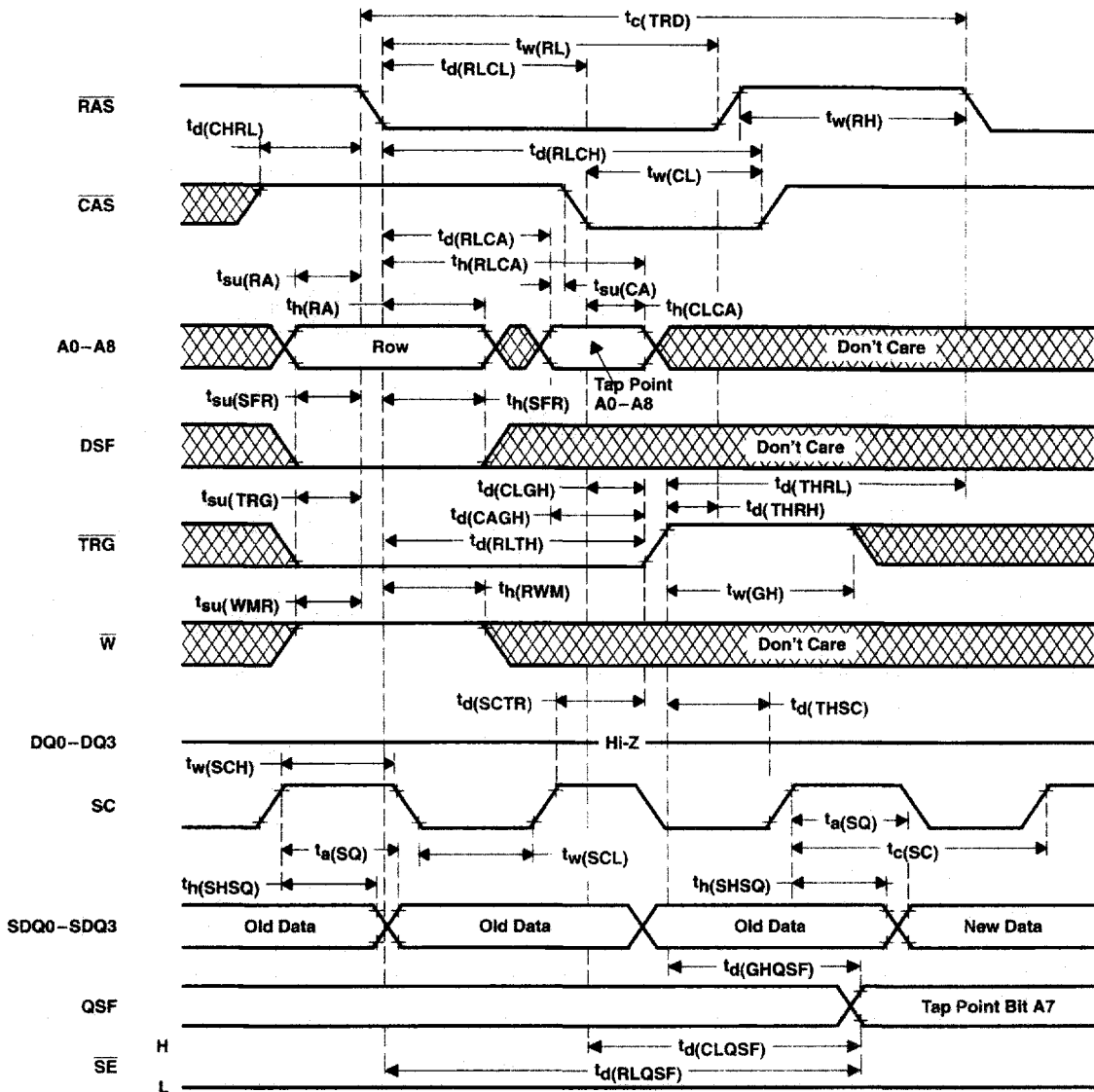

- NOTES: A. Late-load operation is defined as $t_d(\text{THRH}) < 0$ ns.
 B. DQ outputs remain in the high-impedance state for the entire memory-to-data-register transfer cycle. The memory-to-data-register transfer cycle is used to load the data registers in parallel from the memory array. The 512 locations in each data register are written from the 512 corresponding columns of the selected row. The data that is transferred into the data registers can be either shifted out or transferred back into another row.
 C. Once data is transferred into the data registers, the SAM is in the serial read mode (i.e., SQ is enabled), allowing data to be shifted out of the registers. Also, the first bit to be read from the data register after TRG has gone high must be activated by a positive transition of SC.

Figure 32. Memory-to-Data-Register Transfer-Cycle Timing, Real-Time-Reload Operation/Late-Load Operation

PARAMETER MEASUREMENT INFORMATION

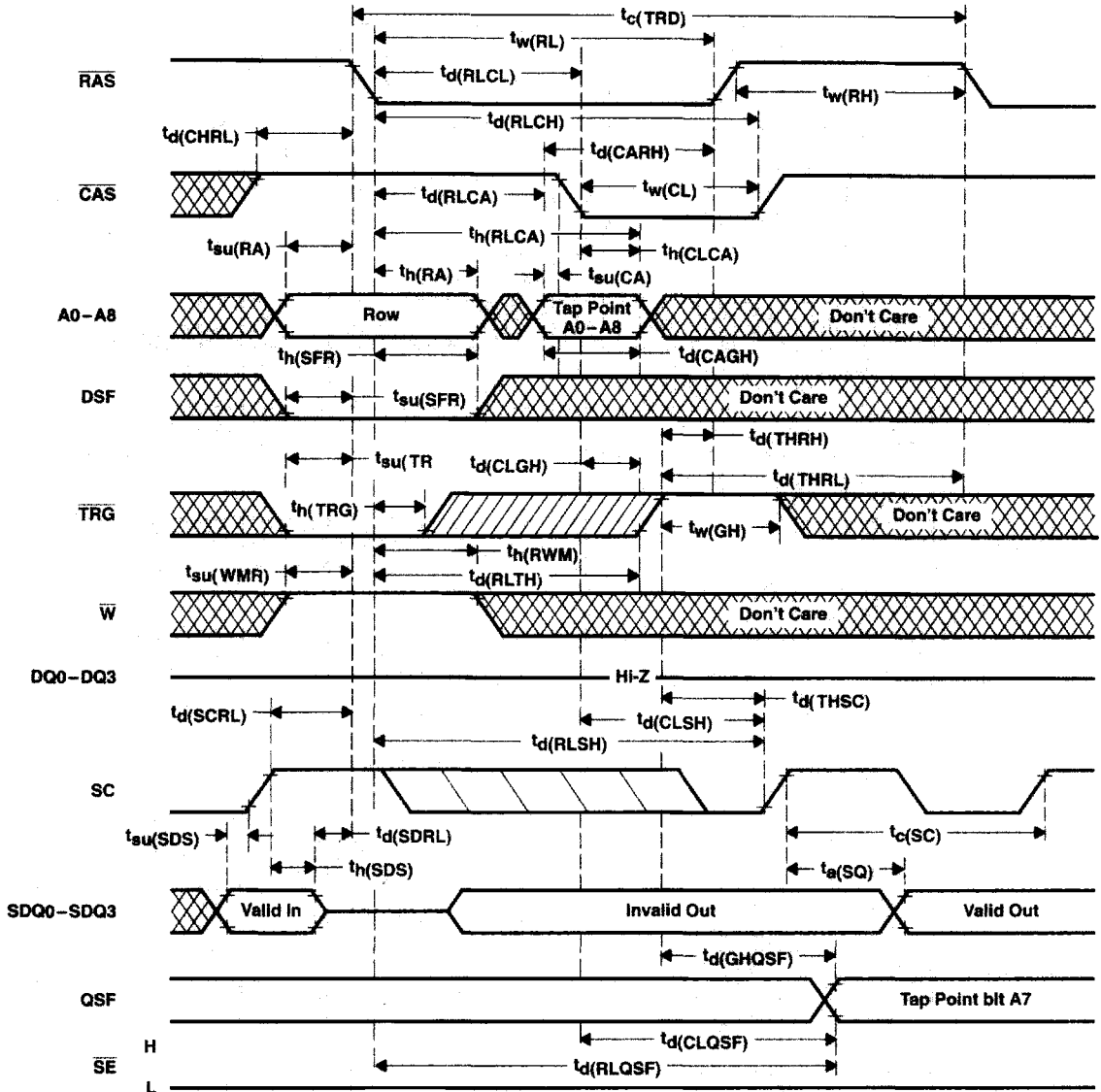

- NOTES: A. Late-load operation is defined as $t_d(THRH) < 0$ ns.
 B. DQ outputs remain in the high-impedance state for the entire memory-to-data-register transfer cycle. The memory-to-data-register transfer cycle is used to load the data registers in parallel from the memory array. The 512 locations in each data register are written from the 512 corresponding columns of the selected row. The data that is transferred into the data registers may be either shifted out or transferred back into another row.
 C. Once data is transferred into the data registers, the SAM is in the serial read mode (i.e., SQ is enabled), allowing data to be shifted out of the registers. Also, the first bit to be read from the data register after \overline{TRG} has gone high must be activated by a positive transition of SC.

Figure 33. Memory-to-Data-Register Transfer-Cycle Timing, SDQ Ports Previously in Serial-Input Mode

SMJ44C251B
262144 BY 4-BIT
MULTIPOINT VIDEO RAM

SGMS058A - MARCH 1985 - REVISED JUNE 1985

PARAMETER MEASUREMENT INFORMATION

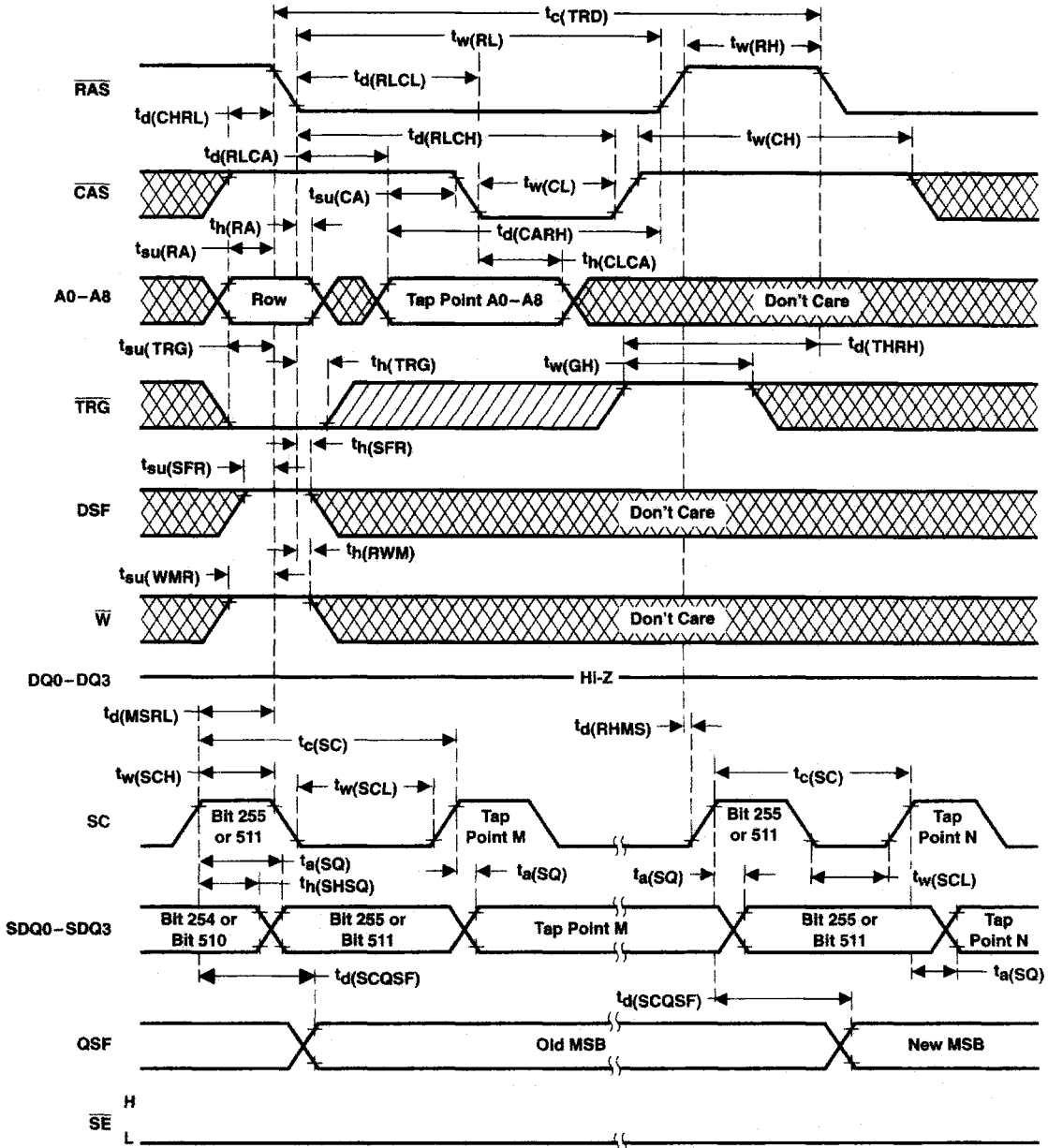
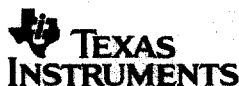
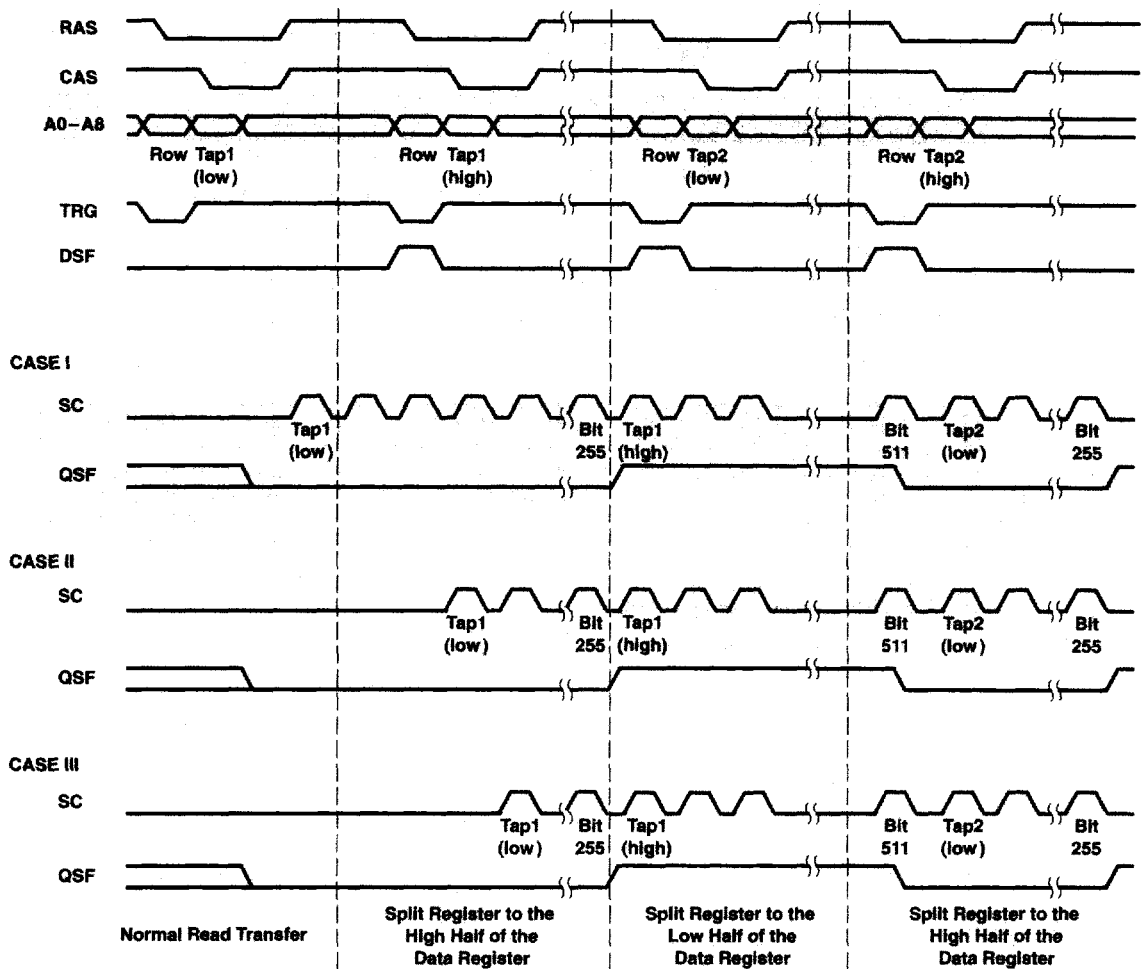

Figure 34. Split-Register-Mode Read-Transfer-Cycle Timing



PARAMETER MEASUREMENT INFORMATION



- NOTES: A. In order to achieve proper split-register operation, a normal read transfer should be performed before the first split-register transfer cycle. This is necessary to initialize the data register and the starting tap location. First serial access can then begin either after the normal read-transfer cycle (CASE I), during the first split-register cycle (CASE II), or even after the first split-register transfer cycle (CASE III). There is no minimum requirement of SC clock between the normal read-transfer cycle and the first split-register cycle.
- B. A split register transfer into the inactive half is not allowed until $t_d(\text{MSRL})$ is met. $t_d(\text{MSRL})$ is the minimum delay time between the rising edge of the serial clock of the last bit (bit 255 or 511) and the falling edge of $\overline{\text{RAS}}$ of the split-register transfer cycle into the inactive half. After $t_d(\text{MSRL})$ is met, the split-register transfer into the inactive half must also satisfy the $t_d(\text{RHMS})$ requirement. $t_d(\text{RHMS})$ is the minimum delay time between the rising edge of $\overline{\text{RAS}}$ of the split-register transfer cycle into the inactive half and the rising edge of the serial clock of the last bit (bit 255 or 511). There is a minimum requirement of one rising edge of SC clock between two split-register transfer cycles.

Figure 35. Split-Register-Transfer Operating Sequence

PARAMETER MEASUREMENT INFORMATION

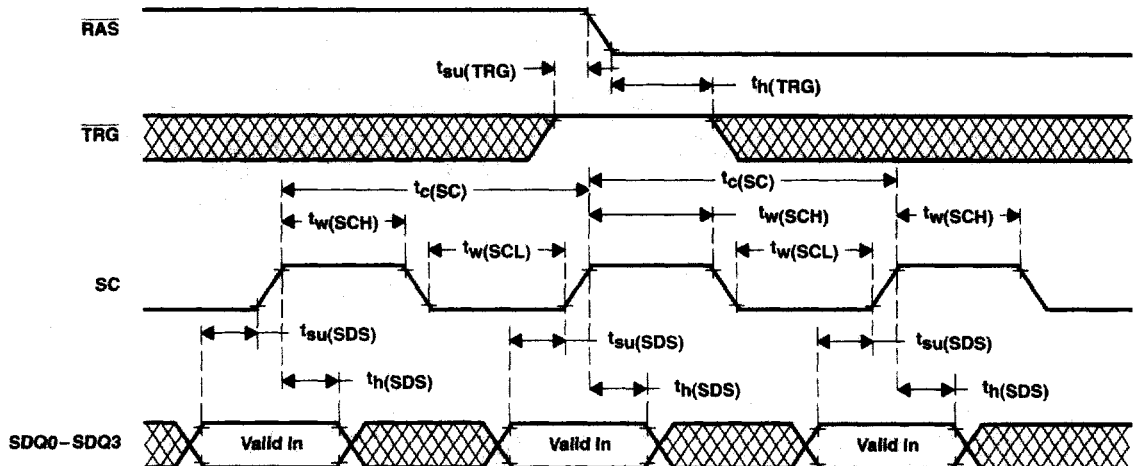

- NOTES: A. The serial data-in cycle is used to input serial data into the data registers. Before data can be written into the data registers via the SDQ terminals, the device must be put into the write mode by performing a write-mode-control (pseudo-transfer) cycle or any other write-transfer cycle. A read-transfer cycle is the only cycle that takes the serial port (SAM) out of the write mode and puts it into the read mode, disabling the input data. Data is written starting at the location specified by the input address loaded on the previous transfer cycle.
- B. While accessing data in the serial-data registers, the state of \overline{TRG} is a don't care as long as \overline{TRG} is held high when \overline{RAS} goes low to prevent data transfers between memory and data registers.

Figure 36. Serial-Write-Cycle Timing ($\overline{SE} = V_{IL}$)

PARAMETER MEASUREMENT INFORMATION

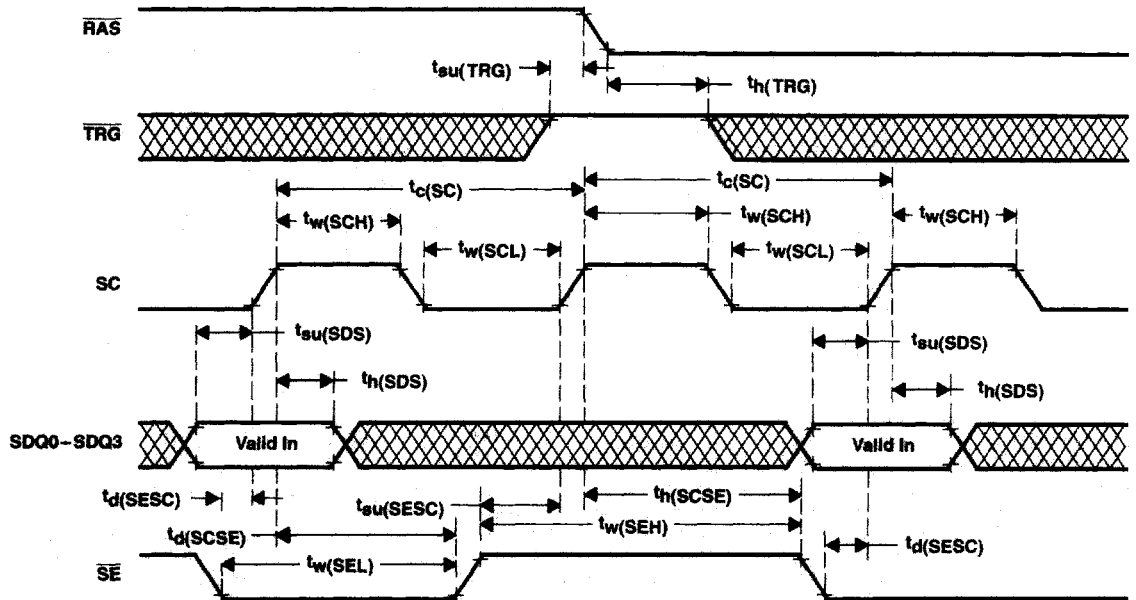

- NOTES: A. The serial data-in cycle is used to input serial data into the data registers. Before data can be written into the data registers via the SDQ terminals, the device must be put into the write mode by performing a write-mode-control (pseudo-transfer) cycle or any other write-transfer cycle. A read-transfer cycle is the only cycle that takes the serial port (SAM) out of the write mode and puts it into the read mode, disabling the input data. Data is written starting at the location specified by the input address loaded on the previous transfer cycle.
- B. While accessing data in the serial-data registers, the state of \overline{TRG} is a don't care as long as \overline{TRG} is held high when \overline{RAS} goes low to prevent data transfers between memory and data registers.

Figure 37. Serial-Write-Cycle Timing (\overline{SE} -Controlled Write)

SMJ44C251B
262144 BY 4-BIT
MULTIPOINT VIDEO RAM

SGMS068A - MARCH 1985 - REVISED JUNE 1985

PARAMETER MEASUREMENT INFORMATION

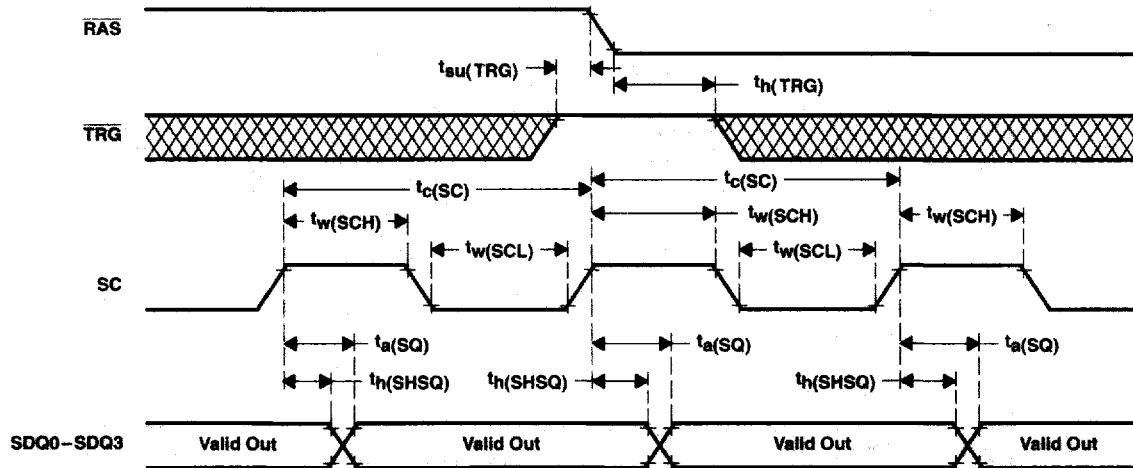

- NOTES: A. While reading data through the serial-data register, the state of \overline{TRG} is a don't care as long as \overline{TRG} is held high when RAS goes low. This is to avoid the initiation of a register-to-memory-to-register data-transfer operation.
- B. The serial data-out cycle is used to read data out of the data registers. Before data can be read via SDQ, the device must be put into the read mode by performing a transfer-read cycle. Any transfer-write cycles occurring between the transfer-read cycle and the subsequent shifting out of data take the device out of the read mode and put it in the write mode, not allowing the reading of data.

Figure 38. Serial-Read-Cycle Timing ($\overline{SE} = V_{IL}$)

PARAMETER MEASUREMENT INFORMATION

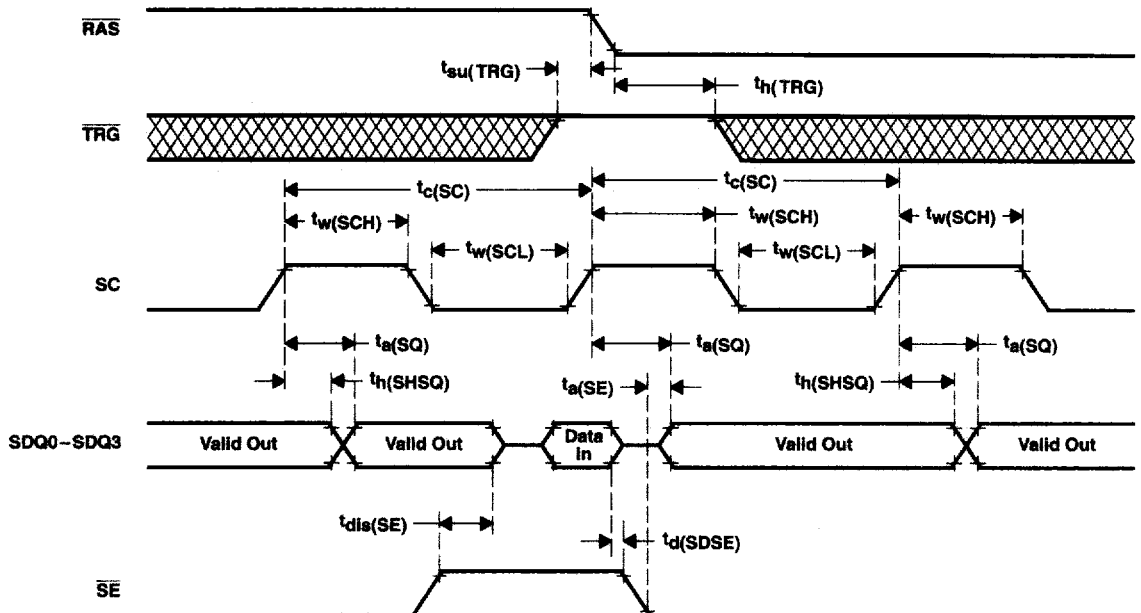

- NOTES: A. While reading data through the serial-data register, the state of \overline{TRG} is a don't care as long as \overline{TRG} is held high when \overline{RAS} goes low. This is to avoid the initiation of a register-to-memory-to-register data-transfer operation.
B. The serial data-out cycle is used to read data out of the data registers. Before data can be read via SDQ, the device must be put into the read mode by performing a transfer-read cycle. Any transfer-write cycles occurring between the transfer-read cycle and the subsequent shifting out of data take the device out of the read mode and put it in the write mode, not allowing the reading of data.

Figure 39. Serial-Read-Cycle Timing (\overline{SE} -Controlled Read)

device symbolization

