

The S-13P48A 4-bit microcomputer integrates 8-bit programmable timer, watch dog timer, carry output circuit, etc., on one chip. As it can be driven by batteries, this microcomputer is ideal for various compact portable equipment.

■ Feature

- Si gate CMOS process
- Low power consumption
- Single power supply : 1.8 V min.(600 KHz)
- High-speed operation : 600 KHz max.
- EPROM: 512×8 bits
- RAM: 16×4 bits
- 5 input lines , 6 output lines and a remote control signal output line
- 2 timers: 8-bit programmable timer and delay timer
- Watch dog timer
- Interrupt function
- Standby function (STOP, HALT)
- Instruction execution time: 8 μ SEC /Inst min. (at 500 KHz)
- Instructions: 79 types (114 including addressing modes) 5-level subroutine nesting
- S-13P48AFE: 18-pin SOP (terminal distance:1.27mm)
- S-13P48AFS: 20-pin SSOP (terminal distance:0.65mm)

■ Applications

- Security system (Car, Home etc.)
- Toys
- Infrared remote controller
- Compact portable equipment, others

CMOS 4-bit 1-chip MICROCOMPUTER S-13P48A

Pin Assignments

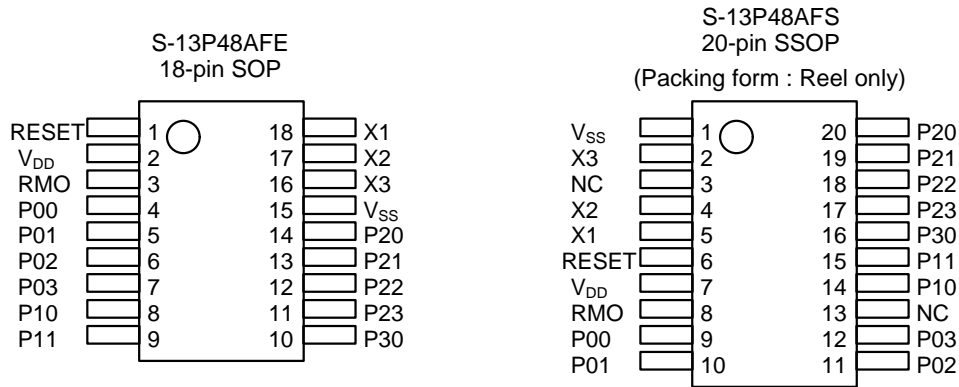

Figure 1

Terminal Functions

Table 1

Name	Normal operation		PROM programming mode	
	I/O	Function	I/O	Function
V _{DD}	—	Positive power supply	—	Positive power supply
V _{SS}	—	GND potential terminal	—	GND potential terminal
RESET	Input	Active high/reset input terminal (built-in Schmitt input, pull-down resistor)	Input	PROM write power supply (12.5 V) or V _{DD}
X1	Input	Condenser and register connect terminal for oscillation circuit X1-X2:C X1-X3:R	Input	Address clock input
X2	Output		Output	(OPEN)
X3	Output		Output	(OPEN)
RMO	Output	Carrier wave output	Input	Mode selection
P ₀₀	Output	Output port (Nch open drain output/CMOS output selection available through software)	Input/ Output	PROM data (D0)
P ₀₁				PROM data (D1)
P ₀₂				PROM data (D2)
P ₀₃				PROM data (D3)
P ₁₀	Output		Output	(OPEN)
P ₁₁				(OPEN)
P ₂₀	Input	Input port (Pullup resistance inclusion available through software)	Input	PROM data (D4)
P ₂₁				PROM data (D5)
P ₂₂				PROM data (D6)
P ₂₃				PROM data (D7)
P ₃₀	Input		Input/ Output	10 KΩ resistance pull-down

■ **Block Diagram**

S-13P48A is connected by 4-bit data bus (DB), 12-bit address bus (AB), control signals, etc., and controls the memories (EPROM, RAM), registers, I/O ports, logic circuits (ALU), timers, etc.

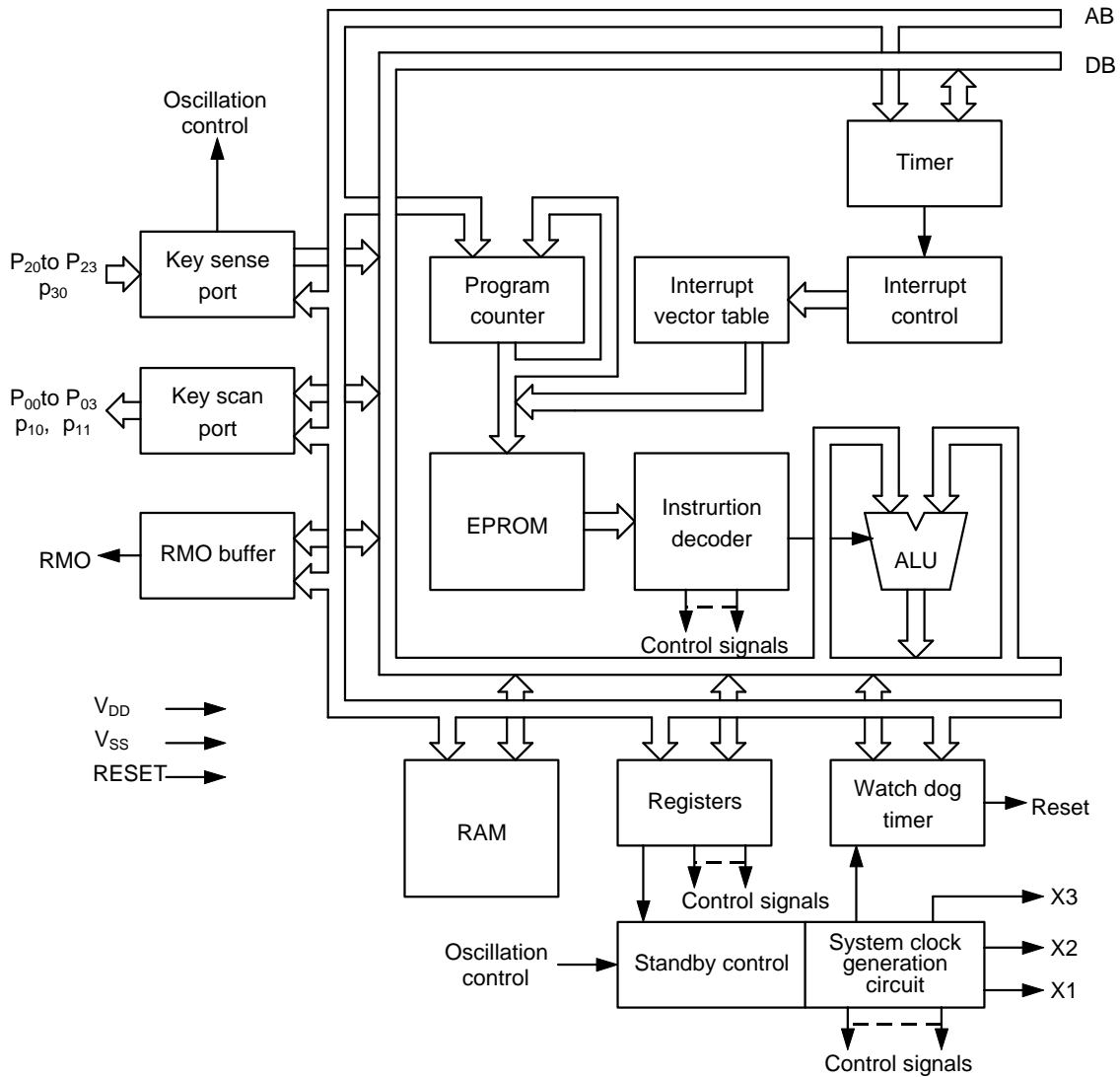

Figure 2

■ **Absolute Maximum Ratings**

Table 2

Item	Symbol	Conditions	Rating	Unit
Storage temperature	Tstg		-40 to +125	°C
Operating temperature	Topr		-20 to +70	°C
Power supply voltage	V _{DD}	Ta = 25°C	-0.3 to 7.0	V
Input voltage	V _{IN}	Ta = 25°C	V _{SS} -0.3 to V _{DD} + 0.3	V
Output voltage	V _{OUT}	Ta = 25°C	V _{SS} to V _{DD}	V
Power dissipation	Pd	Ta = 25°C	300	mW

■ **Recommended Operating Conditions**

Table 3

(Ta=-20°C to +70°C)

Item	Symbol	Conditions	Min.	Typ.	Max.	Unit
Power supply voltage	V _{DD}	System clock : 600 KHz	1.8		5.5	V
Input voltage	V _{IN}		0		V _{DD}	V
System clock frequency	fsys	V _{DD} =1.8 to 5.5V	200		600	KHz

CMOS 4-bit 1-chip MICROCOMPUTER S-13P48A

■ DC Characteristics

Table 4 DC Characteristics (I)

(Ta=-20°C to +70°C, V_{DD}=3.0 V)

Item	Symbol	Conditions	Min.	Typ.	Max.	Unit
Operating current consumption	I _{CCO}	System clock : 455 KHz	—	0.4	0.7	mA
Standby current consumption	I _{CCS}	At STOP mode	—	0.01	1	μA
High level input voltage	V _{IH}		0.8×V _{DD}	—	—	V
Low level input voltage	V _{IL}		—	—	0.2×V _{DD}	V
High level input leakage current	I _{IH}	All input terminals V _{IN} =V _{DD}	—	—	1	μA
Low level input leakage current	I _{IL}	Without pull-up resistor V _{IN} =V _{SS}	-1	—	—	μA
High level input current	I _{IH}	RESET terminal V _{IN} =V _{DD}	0.6	2	6	μA
Low level input current 1	I _{IL1}	With pull-up resistor V _{IN} =V _{SS}	-90	-30	-10	μA
Low level input current 2	I _{IL2}	RESET terminal V _{IN} =V _{SS} +0.3 V	0.9	3	9	μA
High level output current 1	I _{OH1}	RMO terminal, V _{OUT} =2.1 V	—	—	-5.0	mA
High level output current 2	I _{OH2}	P00 to P03 terminal V _{OUT} =2.1 V	—	—	-2.0	mA
High level output current 3	I _{OH3}	P10, P11 terminal V _{OUT} =2.6 V	—	—	-100	μA
Low level output current 1	I _{OL1}	RMO terminal, V _{OUT} =0.4 V	250	—	—	μA
Low level output current 2	I _{OL2}	P00 to P03 terminal V _{OUT} =0.9 V	5	—	—	mA
Low level output current 3	I _{OL3}	Output port, V _{OUT} =0.4 V	1.0	—	—	mA
Schmitt hysteresis width	V _{WD}		—	0.7	—	V

Table 5 DC Characteristics (II)

(Ta=-20°C to +70°C, V_{DD}=5.0 V)

Item	Symbol	Conditions	Min.	Typ.	Max.	Unit
Operating current consumption	I _{CCO}	System clock : 455 KHz	—	1.2	2.0	mA
Standby current consumption	I _{CCS}	At STOP mode	—	0.1	5	μA
High level input voltage	V _{IH}		0.8×V _{DD}	—	—	V
Low level input voltage	V _{IL}		—	—	0.2×V _{DD}	V
High level input leakage current	I _{IH}	All input terminals V _{IN} =V _{DD}	—	—	1	μA
Low level input leakage current	I _{IL}	Without pull-up resistor V _{IN} =V _{SS}	-1	—	—	μA
High level input current	I _{IH}	RESET terminal V _{IN} =V _{DD}	3	9	27	μA
Low level input current 1	I _{IL1}	With pull-up resistor V _{IN} =V _{SS}	-270	-90	-30	μA
Low level input current 2	I _{IL2}	RESET terminal V _{IN} =V _{SS} +0.3 V	3	9	27	μA
High level output current 1	I _{OH1}	RMO terminal, V _{OUT} =2.1 V	—	—	-8.0	mA
High level output current 2	I _{OH2}	P00 to P03 terminal V _{OUT} =4.1 V	—	—	-3.0	mA
High level output current 3	I _{OH3}	P10, P11 terminal V _{OUT} =4.6 V	—	—	-250	μA
Low level output current 1	I _{OL1}	RMO terminal, V _{OUT} =0.4 V	500	—	—	μA
Low level output current 2	I _{OL2}	P00 to P03 terminal V _{OUT} =0.9 V	6.0	—	—	mA
Low level output current 3	I _{OL3}	Output port, V _{OUT} =0.4 V	2.0	—	—	mA
Schmitt hysteresis width	V _{WD}		—	1.3	—	V

■ Instructions

Table 6

	Basic	Including addressing modes
Transfer instruction	13	27
Arithmetic operation instruction	34	47
Logical operation instruction	7	13
Branch instruction	21	21
Shift instruction	2	4
Special instruction	2	2
Total	79	114

■ Application Example

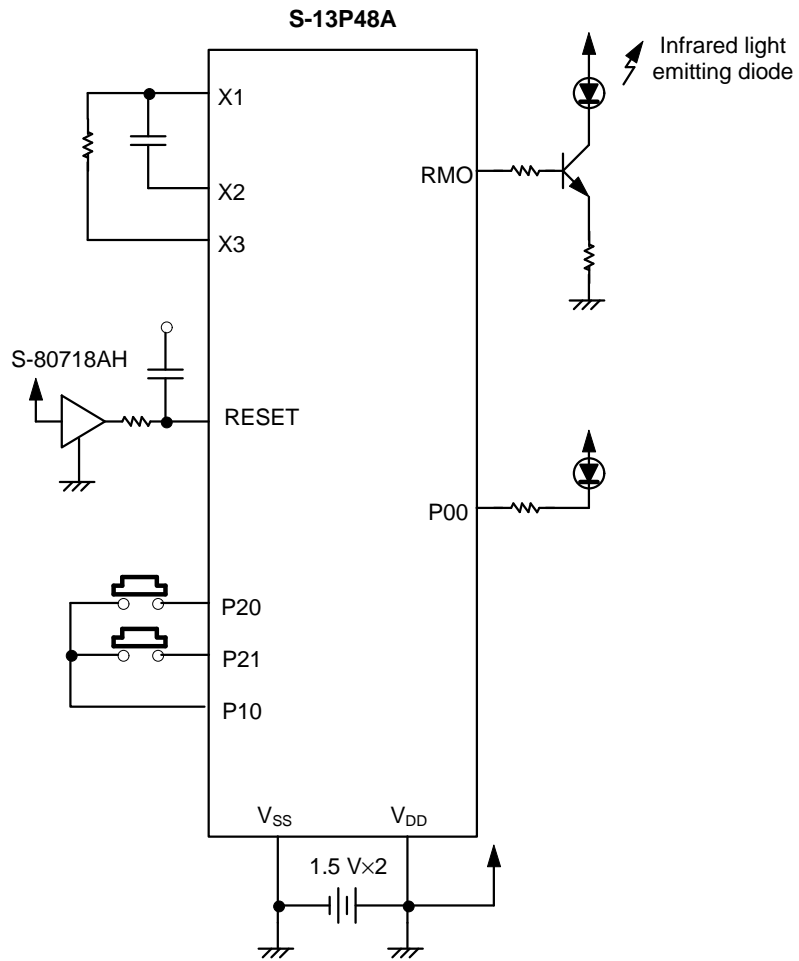

Figure 3

18-pin SOP

FE018-A 990531

Dimensions

Unit:mm

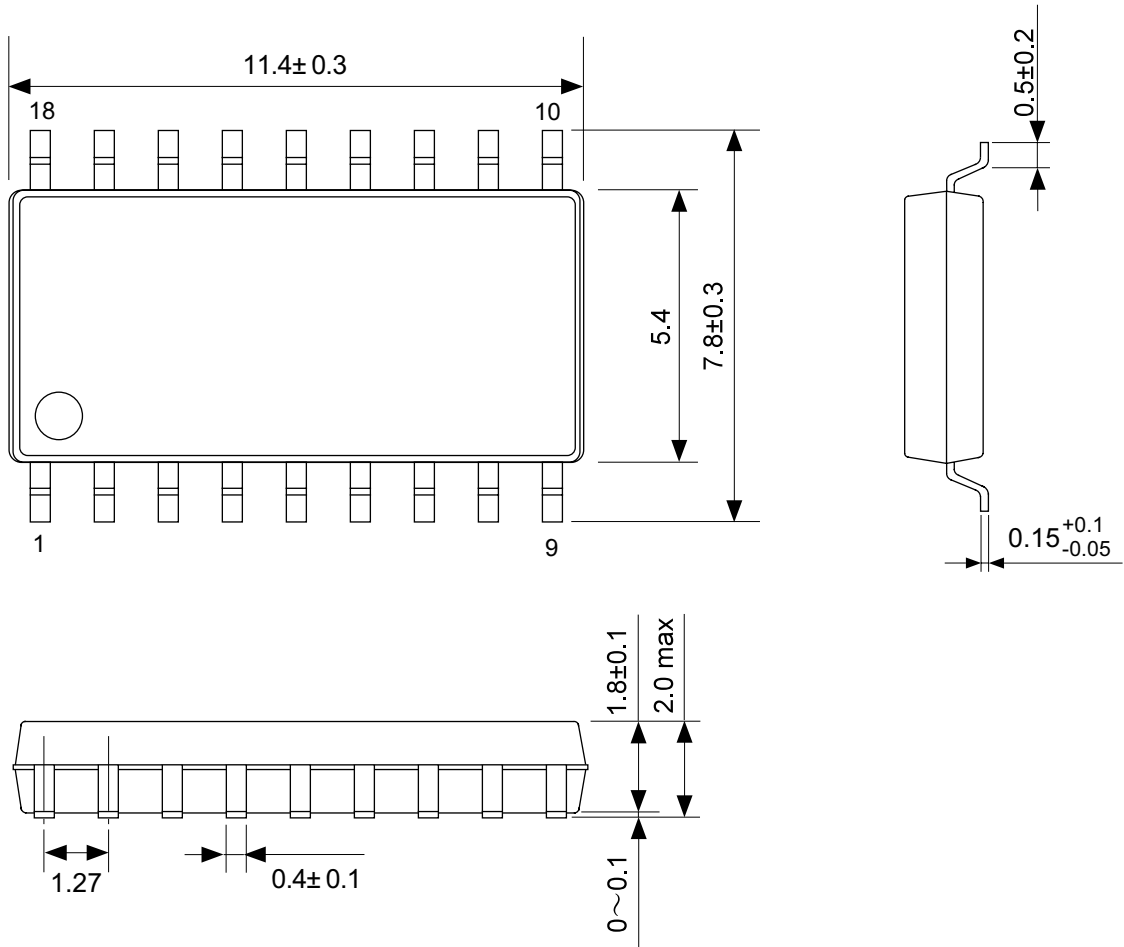

No. : FE018-A-P-SD-1.0

- The information herein is subject to change without notice.
- Seiko Instruments Inc. is not responsible for any problems caused by circuits or other diagrams described herein whose industrial properties, patents or other rights belong to third parties. The application circuit examples explain typical applications of the products, and do not guarantee any mass-production design.
- When the products described herein include Strategic Products (or Service) subject to regulations, they should not be exported without authorization from the appropriate governmental authorities.
- The products described herein cannot be used as part of any device or equipment which influences the human body, such as physical exercise equipment, medical equipment, security system, gas equipment, vehicle or airplane, without prior written permission of Seiko Instruments Inc.