

The ZIF600 synthesiser is for channel selection in 4FSK pagers. A reference frequency is generated by an on-chip crystal oscillator with an AFC external trimming varacator controlled by a DAC.

The ZIF600 digital demodulator uses DSP techniques to optimise the data extraction in the presence of noise and also generates an AFC output to adjust the crystal frequency.

Separate power controls allow the system current consumption to be minimised. All functions are controlled by a serial bus with a simple programming format and with four control pins which are used to control the power up and power down functions of the blocks to allow sequenced wake up and optimised power consumption.

#### FEATURES

- Low Voltage Operation, 2.7 to 3.3V
- On-chip Reference Oscillator
- Channel Select Synthesiser
- Direct VCO input at up to 330MHz
- 6400 Baud Digital 4FSK Demodulator
- Serial Control Bus
- Very Low Power Consumption
- Small QSOP24 Package

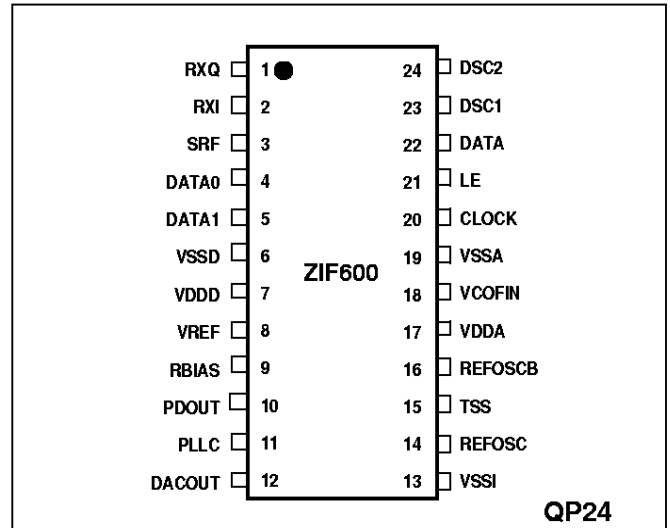

Fig.1 Pin connections - top view

#### APPLICATIONS

- Pagers - including small form factor designs such as credit card pagers, watch pagers and PCMCIA applications
- Low data rate receivers - security/remote control

#### ABSOLUTE MAXIMUM RATINGS

To be defined.

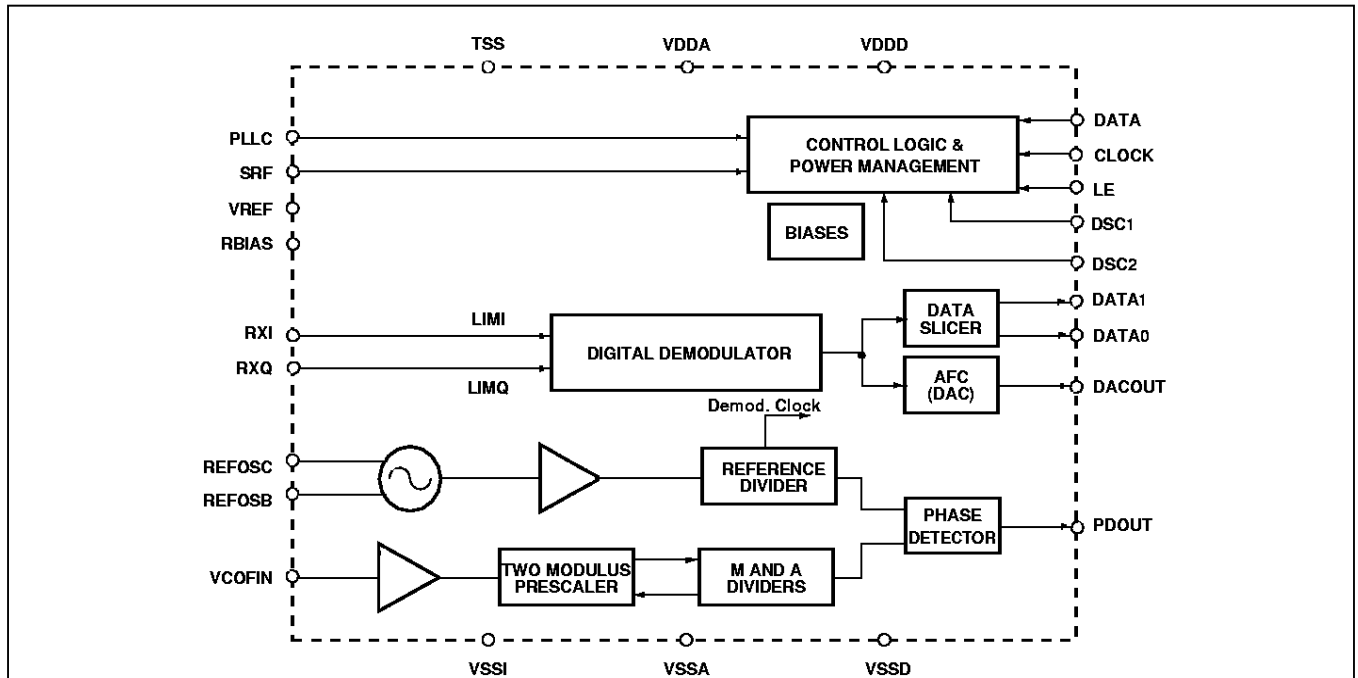

Fig.2 ZIF600 block diagram

## ZIF600

### TARGET ELECTRICAL CHARACTERISTICS

These characteristics are guaranteed over the following conditions (unless otherwise stated):

VDDD, VDDA = 2.7 TO 3.3V, VDD1 = 0.95V to 1.6V (connected to REFOSCB via ext. resistor) and  $T_{amb} = -20$  to  $+70^{\circ}\text{C}$

Characteristic	Min.	Typ.	Max.	Units	Conditions
Supply current at VDDD,VDDA = 3V	-	1	-	mA	Synthesiser locked and demodulator active. VDD1 connected to REFOSCB via external resistor.
Supply current at VDD1 = 1.4V	-	350	-	$\mu\text{A}$	
VREF bias voltage input range	1.15	1.25	1.31	V	
Logic input HIGH, pins DATA, CLOCK, LE, DSC1, DSC2, PLLC, SRF, RXI, RXQ	VDD - 0.3	-	VDD + 0.3	V	
Logic input LOW, pins DATA, CLOCK, LE, DSC1, DSC2, PLLC, SRF, RXI, RXQ	VSS - 0.3	-	VSS + 0.3	V	
Input capacitance (signal pins)	-	-	10	pF	Pin voltage: VSS to VDD
Input leakage (signal pins)	-	-	1	$\mu\text{A}$	Pin voltage: VSS to VDD
Control bus CLOCK frequency	0	-	10	MHz	
Synthesiser charge pump output leakage, pin PDOUT	-	50	-	nA	Pin voltage: VSS to VDD
Synthesiser charge pump output current, pin PDOUT	160	200	240	$\mu\text{A}$	Pin VDD/2
Charge pump output compliance range, pin PDOUT	VSS + 0.4	-	VDD — 0.4	V	Current within 10% of its value at VDD/2
Main synthesiser input frequency on VCOFIN	50	-	330	MHz	
VCOFIN input level	300	-	1000	mV pk - pk	
Reference Frequency Crystal	-	12.8 14.4	-	MHz	Pins REFOSC and REFOSCB
Logic output HIGH, pins DATA0, DATA1	VDD — 0.3	-	VDD	V	Output current, $I_{OH} = 100\mu\text{A}$
Logic output LOW, pins DATA0, DATA1	VSS	-	VSS — 0.3	V	Output current, $I_{OL} = 100\mu\text{A}$ .
Trim DAC output voltage, pin DACOUT	0	-	2.375	V	Not tested Output current 100nA VREF = 1.25V
RXI, RXQ pull-up current	1.5	-	-	$\mu\text{A}$	VDD — 0.3V
RXI, RXQ pull-down current	-	-	40	$\mu\text{A}$	VSS + 0.3V
Input leakage (signal) pins with pull-downs	-	-	3	$\mu\text{A}$	Pin voltage: VSS to VDD pins include SRF, PLLC DSC1, DSC2

## DESCRIPTION OF FUNCTIONS

Pin No.	Pin Name	Pin Type	Description
1	RXQ	In	Receiver "Quadrature" output
2	RXI	In	Receiver "In Phase" output
3	SRF	In	Symbol Rate Filter
4	DATA0	Out	Data output to decoder
5	DATA1	Out	Data output to decoder
6	VSSD	G	Digital Ground
7	VDDD	P	2.7 to 3.3V Digital Power Supply
8	VREF	In	1.25 Volt Reference from ZIF100
9	RBIAS	In	Bias setting Resistor 120k $\Omega$ to VSSA max. parasitic capacitance = 5pF
10	PDOUT	Out	Charge pump output from synthesiser
11	PLL	In	Synthesiser power down
12	DACOUT	Out	Trim DAC for crystal
13	VSS1	G	Ground (substrate)
14	REFOSC	I/O	Reference Oscillator
15	TSS	In	Test Scan Select, Normally logic 0
16	REFOSCB	I/O	Reference Oscillator. External resistor to VDD1
17	VDDA	P	2.7 to 3.3V Analog Power Supply
18	VCOFIN	In	VCO frequency input to synthesiser
19	VSSA	G	Analog Ground
20	CLOCK	In	Control Bus Clock
21	LE	In	Control Bus Latch Enable
22	DATA	In	Control Bus Data
23	DSC1	In	With DSC2 controls the operating mode of the demodulator
24	DSC2	In	With DSC1 controls the operating mode of the demodulator

Table 1. List of pins

## FUNCTIONAL DESCRIPTION

The ZIF600 synthesiser is used to select the channel in 4FSK paging receivers and uses on-chip constant current charge pumps to drive an external passive loop filter. Common low cost reference crystals are used, at frequencies of 12.8 or 14.4MHz, and are divided to give the required 12.5, 20 or 25kHz channel spacings. The reference crystal oscillator uses external trimming to meet system requirements and is controlled by a DAC set by the digital demodulator.

The digital demodulator takes the limited I and Q signals from the radio receiver and converts the 4-level FSK into 2 bit data output on pins DATA0 and DATA1. An AFC output from this demodulator is also included.

Functions are controlled by a serial bus with a simple programming format and with four control pins to allow optimum power up sequences which help minimise the system current consumption.

Crystal MHz	Comp. freq. kHz	Total division	RD1	RD2	RD3
12.8	25	512	0	0	0
14.4	25	576	1	0	0
12.8	20	640	0	1	0
14.4	20	720	1	1	0
12.8	12.5	1024	0	0	1
14.4	12.5	1152	1	0	1
12.8	10	1280	0	1	1
14.4	10	1440	1	1	1

Table 2 Reference divider ratios

## REFERENCE DIVIDERS

The reference frequency generated by the oscillator on pins REFOSC and REFOSCB is divided to give the comparison frequency clock. See Fig. 3.

Ratio selection is five control bits RD1 (where LOW gives  $\div 8$  mode), RD2 (where LOW gives  $\div 4$  mode) and RD3 (where LOW gives  $\div 2$  mode) which can be set to give the 8 options needed to get 10kHz, 12.5kHz, 20kHz or 25kHz from either a 12.8 or 14.4MHz crystal, as in Table 2. The additional control bits RD4 and RD5 allow the option of further division to allow for an off chip frequency multiplier. If both RD4 and RD5 are set low then this division stage is bypassed. Other settings for RD4 and RD5 offer division by 2, 3 or 4. Table 3 shows the additional division options available from RD4 and RD5.

Power down options are available for both the synthesiser and demodulator, however the crystal oscillator and the reference divider must be kept running to give a timing signal to the demodulator whilst the demodulator is on.

Additional division	RD4	RD5
Bypass	0	0
2	0	1
3	1	0
4	1	1

Table 3 Additional divider ratios

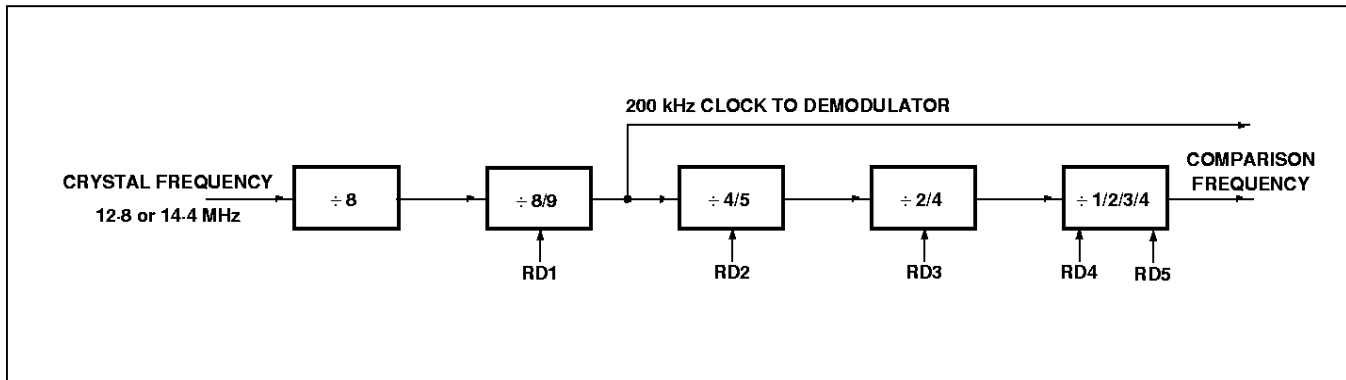

Fig.3 Reference divider configuration

**SYNTHESISER**

The Synthesiser divides the VCOFIN frequency by the 16-bit number FCH programmed from the serial bus and then the phase detector compares the result with the comparison frequency signal to generate correction pulses. The division ratio range is 4,032 to 65,535.

An embedded two modulus prescaler is used to minimise power consumption but its programming is arranged to be transparent to the user.

By using a digital phase and frequency detector the loop will pull in over an unlimited range and then by using a reset signal fed back from the output current drivers any delays in the output path do not give a dead band in the phase response.

The charge pump currents are set by internal biasing. The current level fixed by the circuit has been selected to give minimum loop disturbance from external interference, while also not taking excessive current from the supply line. It is expected that adequate high frequency decoupling will be provided on the power supplies to eliminate any significant noise.

Powering up the synthesiser requires that VREF, IBIAS and PLLC have been turned on for an adequate time before the synthesiser is required to be functioning.

As the demodulator takes its clock from the synthesiser reference divider, the synthesiser reference oscillator and divider circuits must be on and have settled before the demodulator is turned on.

Setting the "DMO" bit in the control bus allows the main parts of the synthesiser to be kept in a low power mode with only the reference oscillator and reference divider operating, when PLLC is high. This effectively allows the demodulator to be used standalone with its required clock being provided by the reference oscillator/divider.

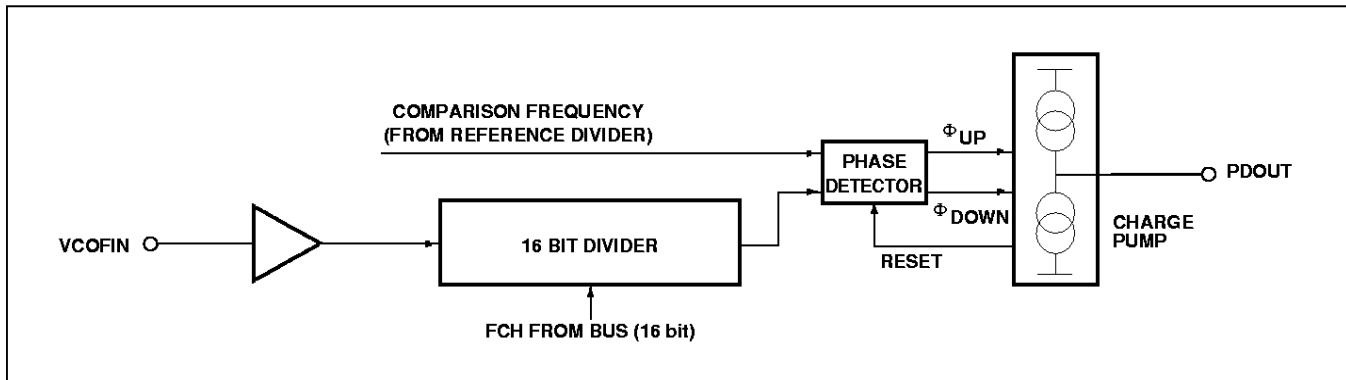

Fig.4 Basic block diagram of synthesiser

"DMO" bit	PLLC	Synthesiser Mode
0	0	Synthesiser off
1	0	Synthesiser off
0	1	Synthesiser on
1	1	Reference oscillator and divider on, remainder of synthesiser circuitry off

Table 4. Synthesiser mode control

### DIGITAL DEMODULATOR

By using digital signal processing techniques it is possible to get a very robust demodulator for 4-level FSK. The demodulator produces a digital level depending on the received frequency. A digital data slicer is used to encode the DATA0 and DATA1 signals. Extra functions are included to give an AFC signal to the 8 bit Trim DAC for the crystal oscillator. The DAC output will lag the incoming data, and will require some external filtering to smooth DAC transitions (it is recommended to connect a 10µF capacitor from DACOUT to Ground).

The demodulator receives "I" and "Q" signals from the ZIF100. Fig.5 shows the DATA0 and DATA1 response to a 4 level I/Q input at ±4.8kHz from te ZIF100. Table 5 maps the input frequency represented by the I/Q demodulator inputs to the DATA0 and DATA1 outputs.

The decoder will recover the symbol clock and sample the DATA0 and DATA1 signals at the appropriate time. DATA1 will have multiple edges during symbol transmissions.

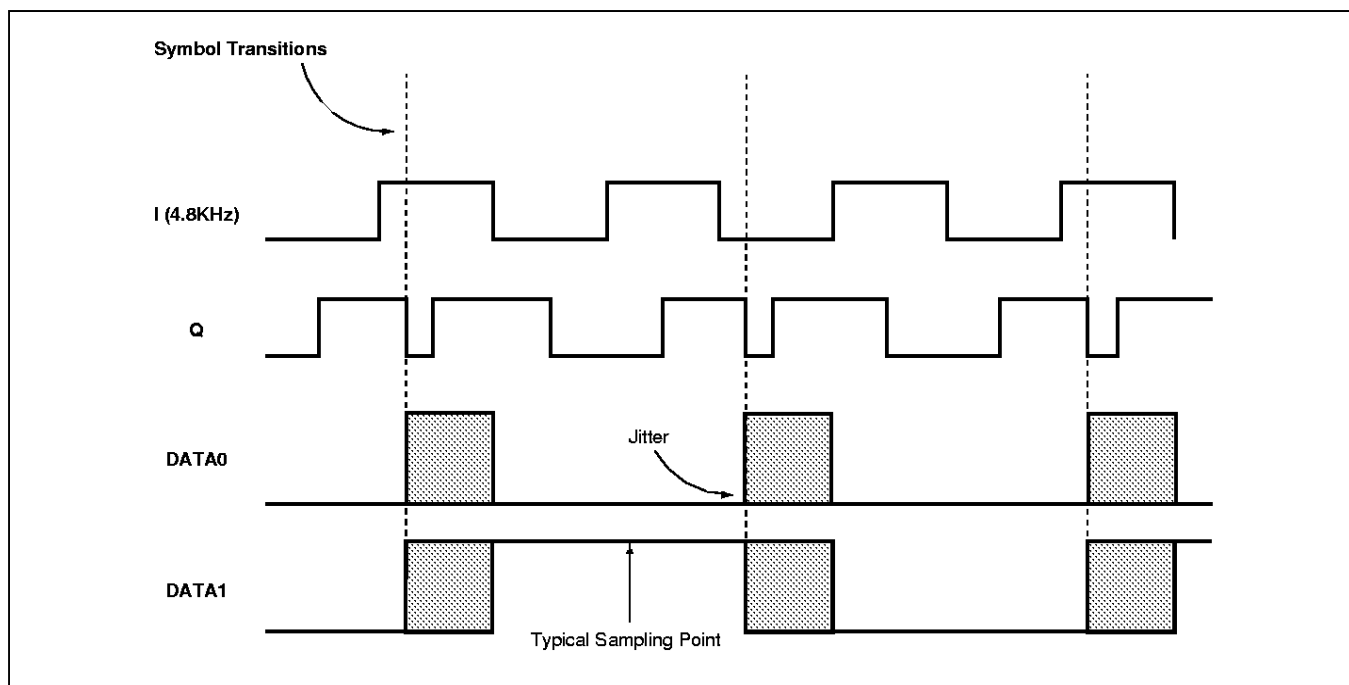

Fig.5 Response of DATA0 and DATA1 to a ±4.8kHz I/Q input

DATA1	DATA0	Frequency Deviation
1	0	+4.8kHz
1	1	+1.6kHz
0	1	-1.6kHz
0	0	-4.8kHz

Table 5. Frequency map for DATA output pins

In a typical application the ZIF600 receives real time control from a decoder interface and provided the decoder with DATA0 and DATA1. Fig.6 illustrates the sequence of applied signals from the Decoder in a typical application. Note that other system ICs will require additional control, and this may affect the sequencing given.

DSC2	DSC1	Demodulator Mode
0	0	Off, Hold Data Slicing and AFC loop values
1	0	On, Fast Tracking for Data Slicing and AFC loop
0	1	On, Slow Tracking for Data Slicing and AFC loop
1	1	Off, Hold applied to Data Slicing and AFC loop values

Table 6. Demodulator mode control

SRF	Symbol Rate
0	Symbol Rate Filter 1600sps
1	Symbol Rate Filter 3200sps

Table 7. Symbol rate filter control

# ZIF600

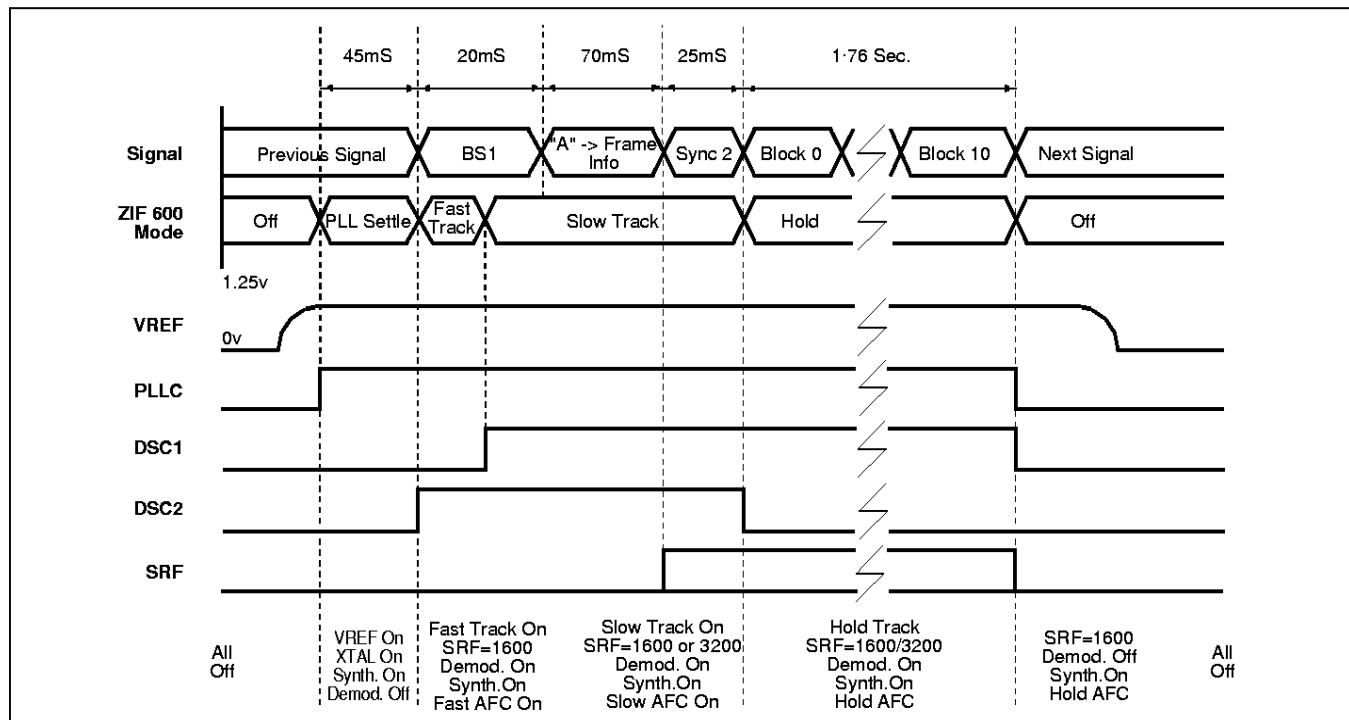

Fig.6 Control signal timing diagram for ZIF600 receiving data

## CONTROL BUS

The ZIF600 has its synthesiser and demodulator configured by a three wire control bus (CLOCK, DATA, LE). The ZIF600 must have these commands applied to it before it can be used. Each command must be complete. Data is clocked into the ZIF600 on the rising edge of the clock. Data is latched into the internal registers when ENABLE is high. Since the ENABLE pin gives a direct load and also resets some circuits, there will be a phase discontinuity if data is loaded after the synthesiser has settled. The bus clock does not need to run between messages and to minimise interference to radio receiver circuits it is recommended that the clock is stopped whenever it is not needed. Fig. 7 shows the format of the control bus.

th	ts	tpw	tse	tpe
20nS	20nS	50nS	20nS	50nS

Control bus timing (provisional)

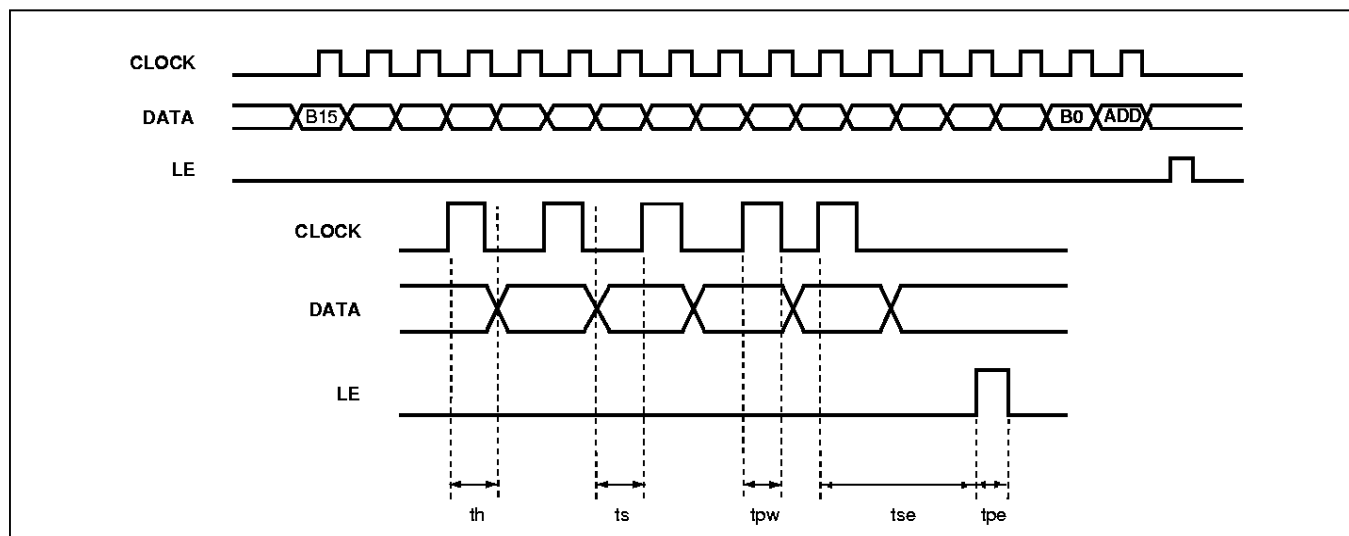

Fig.7 Control bus waveforms

**PROGRAMMING FORMAT (PRELIMINARY)**

Time Order	First.....															...Last	
Bit No. (B)	15	14	13	12	11	10	9	8	7	6	5	4	3	2	1	0	ADD
Synthesiser	FCH "0"															"0"	
System Set-up	"0"	"0"	"0"	"0"	"0"	"0"	"0"	"0"	"0"	DMO	RD5	RD4	RD3	RD2	RD1	"0"	"1"

Table 8. Programming format

Within each field parameters are ordered MSB first and then in descending order. Data is retained by ZIF600 until VDDD is removed.

Name	Length	Meaning
FCH	16 bit word	Synthesiser programmable divider ratio
RD5 -> RD1	5 Bits	programming word to set crystal reference division ratio
DMO	1	Demodulator only operation. Set to "1" to power up only the reference oscillator and divider with "PLL" pin, generating demod. clock & leaving the remainder of PLL in power down.

Table 9. Control bus bit definitions

**APPLICATIONS INFORMATION**

By using constant current charge pumps the synthesiser loop filter is purely passive. See Fig.8.

It is recommended that the primary filter is placed as close to the synthesiser circuit as possible to minimise interference caused by charge pump current pulses. The high frequency clean-up filter, if needed at all, can be placed nearer the VCO as required for board layout.

Suggested component values for ΔkHz comparison frequency with a 5MHz/volt VCO are:

- R1 = 15kΩ
- C1 = 220nF
- CP = 18nF
- RF = 47kΩ
- CF = 1.8nF

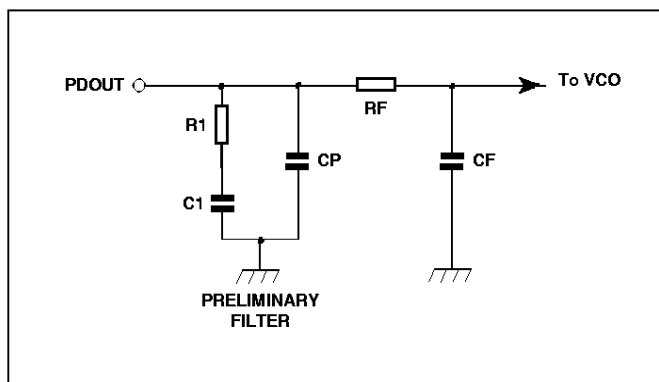
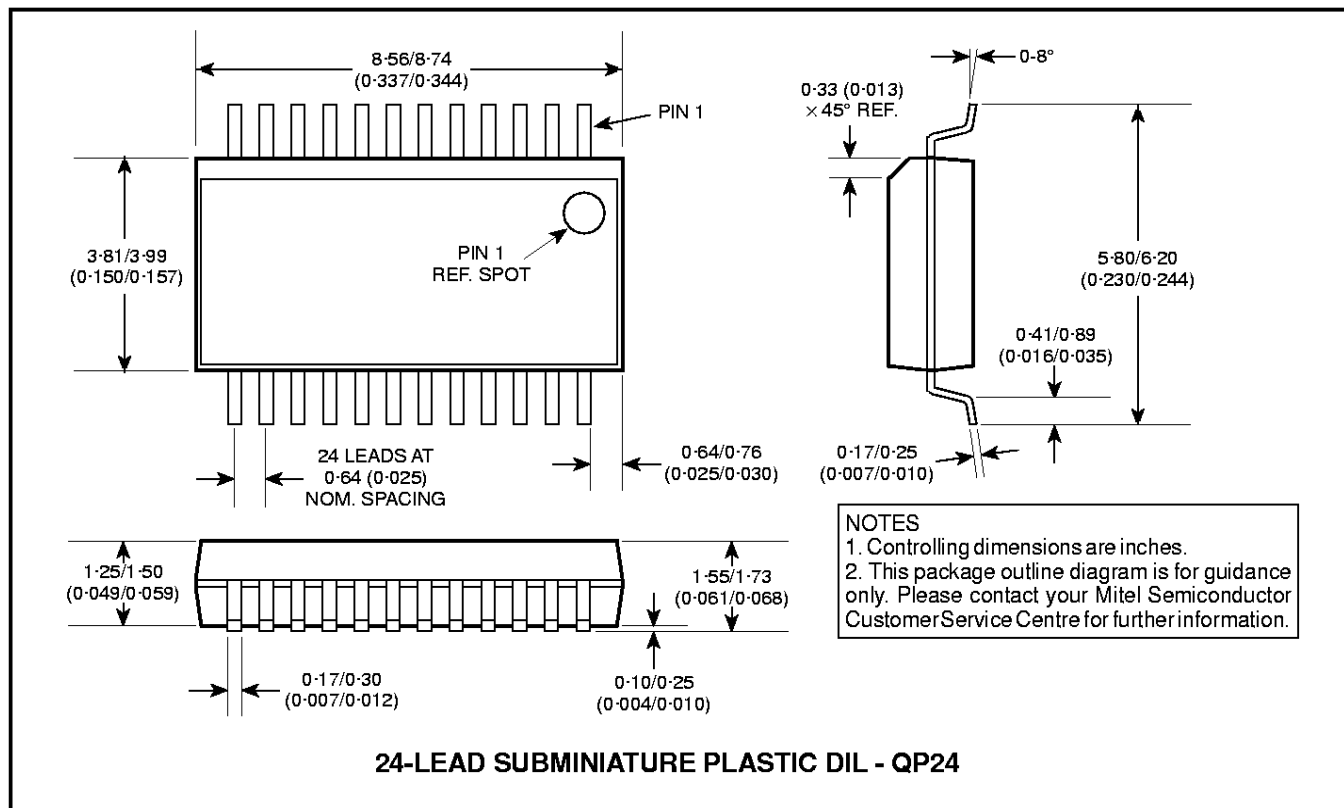

Fig.8 Typical synthesiser loop filter

# ZIF600

## PACKAGE DETAILS

Dimensions are shown thus: mm (in). For further package information, please contact your local Customer Service Centre.



**HEADQUARTERS OPERATIONS**  
**MITEL SEMICONDUCTOR**  
Cheney Manor, Swindon,  
Wiltshire SN2 2QW, United Kingdom.  
Tel: (01793) 518000  
Fax: (01793) 518411

**MITEL SEMICONDUCTOR**  
1500 Green Hills Road,  
Scotts Valley, California 95066-4922  
United States of America.  
Tel (408) 438 2900  
Fax: (408) 438 5576/6231

**Internet: <http://www.gpsemi.com>**

**CUSTOMER SERVICE CENTRES**

- **FRANCE & BENELUX** Les Ulis Cedex Tel: (1) 69 18 90 00 Fax : (1) 64 46 06 07
- **GERMANY** Munich Tel: (089) 419508-20 Fax : (089) 419508-55
- **ITALY** Milan Tel: (02) 6607151 Fax: (02) 66040993
- **JAPAN** Tokyo Tel: (03) 5276-5501 Fax: (03) 5276-5510
- **KOREA** Seoul Tel: (2) 5668141 Fax: (2) 5697933
- **NORTH AMERICA** Scotts Valley, USA Tel: (408) 438 2900 Fax: (408) 438 5576/6231
- **SOUTH EAST ASIA** Singapore Tel:(65) 3827708 Fax: (65) 3828872
- **SWEDEN** Stockholm Tel: 46 8 702 97 70 Fax: 46 8 640 47 36
- **TAIWAN, ROC** Taipei Tel: 886 2 25461260 Fax: 886 2 27190260
- **UK, EIRE, DENMARK, FINLAND & NORWAY**  
Swindon Tel: (01793) 726666 Fax : (01793) 518582

These are supported by Agents and Distributors in major countries world-wide.

© Mitel Corporation 1998 Publication No. DS4771 Issue No. 1.2 October 1997

TECHNICAL DOCUMENTATION – NOT FOR RESALE. PRINTED IN UNITED KINGDOM

This publication is issued to provide information only which (unless agreed by the Company in writing) may not be used, applied or reproduced for any purpose nor form part of any order or contract nor to be regarded as a representation relating to the products or services concerned. No warranty or guarantee express or implied is made regarding the capability, performance or suitability of any product or service. The Company reserves the right to alter without prior notice the specification, design or price of any product or service. Information concerning possible methods of use is provided as a guide only and does not constitute any guarantee that such methods of use will be satisfactory in a specific piece of equipment. It is the user's responsibility to fully determine the performance and suitability of any equipment using such information and to ensure that any publication or data used is up to date and has not been superseded. These products are not suitable for use in any medical products whose failure to perform may result in significant injury or death to the user. All products and materials are sold and services provided subject to the Company's conditions of sale, which are available on request.

All brand names and product names used in this publication are trademarks, registered trademarks or trade names of their respective owners.