

LE79112 VOICE CONTROL PROCESSOR

APPLICATIONS

- CO
- IVD
- PBX
- KTS

FEATURES

- Software interface using VP API-II
- Software downloadable, field upgradable, expandable
- Provides expanded line and circuit testing in conjunction with Legerity's VE790 Series of chip sets
- DTMF detection
- Quad tone and howler tone generation
- Arbitrary single tone detection
- 15-kHz energy detection
- SNR tests
- Dial pulse measurement

The Le79112 Voice Control Processor (VCP) is a digital signal processing platform that works with the Legerity VE790 Series of chip sets using the MPI interface, PCM port, and an interrupt line from the codec/filter. The primary functions of the Le79112 VCP are to program and control the codec/filter via an Application Programming Interface (API). Firmware residing in the DSP's RAM provides enhanced call processing and test capabilities.

The Le79112 VCP in combination with a VE790 Series chip set, supports up to 32 channels of universal telephone line interface with high-level voice functionality. The solution enables the design of a low-cost, high-performance, fully software programmable line interface for multiple country applications. All of the AC, DC, signaling parameters, and data are fully programmable via the Host Bus Interface (HBI) through the combination of the HBI and a slave PCM port.

Additionally, the Le79112 VCP has integrated self-test and line-test capabilities to resolve faults to the line or line circuit. The integrated test capability is crucial for remote applications where dedicated test hardware is not cost effective.

There are four firmware options offered for the Le79112 VCP device:

- LineCare™ Call Control - Le79112SLNT
- LineCare™ Basic Test - Le79112SLBT
- LineCare™ Advanced Test - Le79112SLAT
- LineCare™ Advanced Test Plus - Le79112SLATP



Le79112 Voice Control Processor

SYSTEM BLOCK DIAGRAM



VCP Application Board

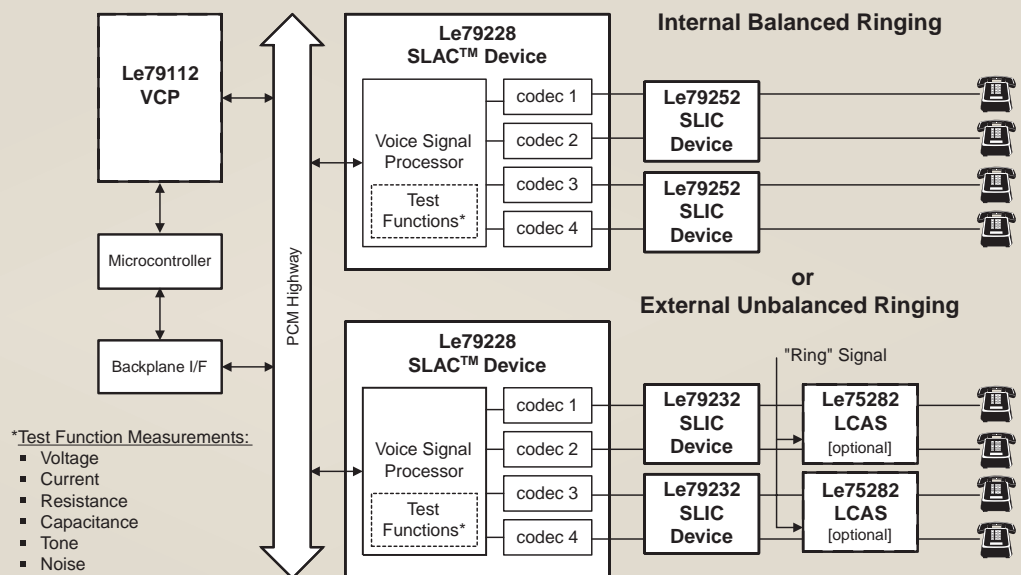

SLAC™ devices are also available in 2-, 4-, and 8-channel versions.

Major Call Control Features

- 32-Channel Call Control
 - Control/Coordination of Call Processing
 - CID high level interface
 - Control for Metering
- DTMF Detection
 - Up to 16 lines simultaneously
 - Q.24 compliant
- Pulse Dial Timing with Decode
 - 32 simultaneous channels
 - Adjustable timing parameters for Make, Break, Flash, and Disconnect
- Zero-Cross Detection for ringing on/off control
- Optional make-before-break, or break-before-make (with LCAS)
- Adjustable delays for internal ringing
- AC and DC fault detection with automatic disconnect of the line
- Slow ramp from Disconnect to Standby
 - Programmable ramp time (0-4000ms)
- Read loop conditions while in service
 - Line Current (Metallic and Longitudinal)
 - Sensed Voltage
 - Current battery supply voltages
- Howler Tone generation

Minor Call Control Features

- Loadable Image
 - Field firmware updates (compressed image support)
- Programmable on/off for each fault type
- Automatic switch to "Active" (Talk) on ring-trip/off-hook
 - Minimizes the delay for ring-trip; no host interaction needed
- Automatic Ringing and Metering Cadencing
- Smooth polarity reversal control
- Checksum over Program Code space while in-service

The VCP Package

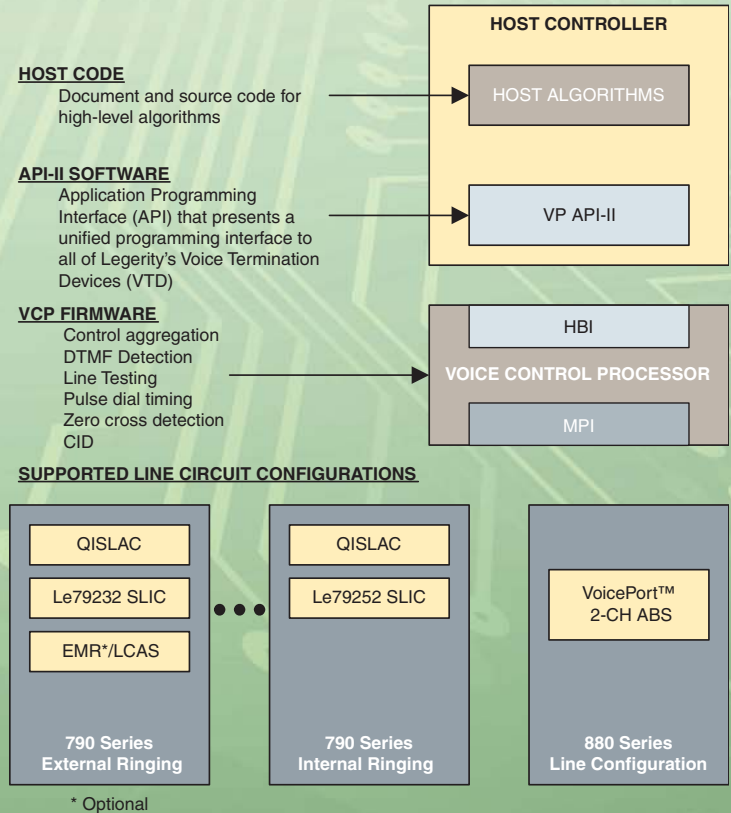

RELATED COLLATERAL

AVAILABLE ON WWW.LEGERITY.COM

- VCP Basic Test Product Brief (#081332)
- VCP Advanced Test Product Brief (#081333)
- VCP Advanced Test Plus Product Brief (#081334)
- VCP Configuration A (External Ringing with LCAS) (#081051)
- VCP Configuration B (Internal Ringing with Test-Out Bus) (#081168)
- VCP Configuration C (Internal Ringing with NO test Bus) (#081218)
- VCP Configuration E (External Ringing configuration with NO test Bus) (#081498)



Legerity was acquired on August 3, 2007 by Zarlink Semiconductor and was incorporated into the Wired Communications product group which also includes Zarlink's timing, synchronization, voice processing and hands free products.

Legerity products are the world's most trusted name in voice integrated circuits (ICs) and have earned industry trust through years of demonstrated expertise in multiple voice technologies. With its office in Austin, Texas, Zarlink's Legerity voice products support the needs of a diverse, global customer base through proprietary semiconductor technologies.

4509 Freidrich Lane, Bldg. 2, Ste. 200
Austin, TX 78744-1812
512.228.5400 - www.legerity.com

FOR MORE INFORMATION:

To find the Legerity Sales Office nearest you, visit our website at: www.legerity.com or email sales@legerity.com
To download or order data sheets, application notes, or evaluation tools, go to: www.legerity.com
For all other technical inquiries, please email Legerity Tech Support at: techsupport@legerity.com

Document ID #081326, Rev. B2
September 28, 2007