

Features

- **Autonomous Frame Sync Detection for SFR operation**
- **Full Packet Data Framing**
- **Powersave Option**
- **Low Power, 3.0 to 5.5V operation**

Applications

- **DataTACTM, MOTIENTSM/ARDISSM, Dual Mode (RD-LAPTM and MDC4800 Systems)**
- **Two-Way Paging Equipment**
- **Mobile Data Systems**
- **Wireless Telemetry**
- **DataTACTM Terminals**

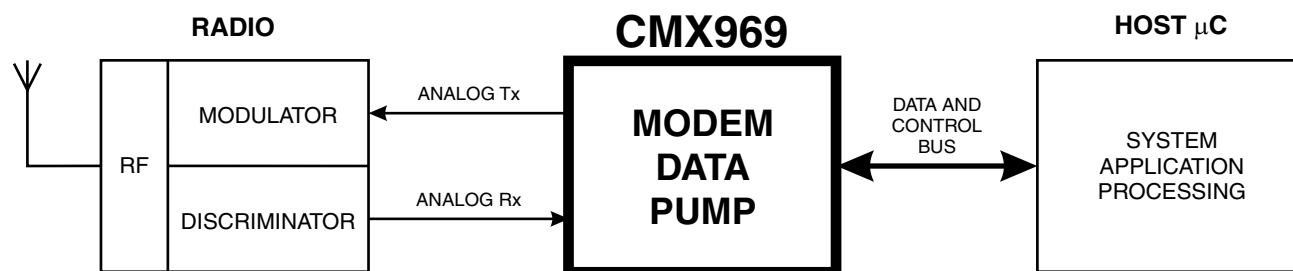

The CMX969 is a CMOS integrated circuit that contains all of the baseband signal processing and Medium Access Control (MAC) protocol functions required for a high performance DataTAC dual mode (RD-LAP 19.2kbps and MDC4800 4.8kbps) FSK Wireless Packet Data Modem suitable for use with the MOTIENT/ARDIS network. It interfaces with the modem host processor and the radio modulation/demodulation circuits to deliver reliable two-way transfer of the application data over the wireless link.

The CMX969 assembles application data received from the host processor, adds forward error correction (FEC) and error detection (CRC) information and interleaves the result for burst-error protection. After adding symbol and frame synchronization codewords and channel status symbols, it converts the packet into a filtered analog baseband signal for modulating the radio transmitter.

In receive mode, the CMX969 performs the reverse function using the analog baseband signals from the receiver frequency discriminator. After error correction and removal of the packet overhead, the recovered application data is supplied to the host processor. Any residual uncorrected errors in the data will be flagged. A readout of the received signal quality is also provided.

An optional Autonomous Frame Sync Detection function is provided for use in MOTIENT/ARDIS systems employing Single Frequency Re-use operation.

The CMX969 uses signal filtering, data block formats and FEC/CRC algorithms compatible with the MDC and RD-LAP over-air standards. The device is programmable to operate from a wide choice of Xtal frequencies and is available in 24-pin PDIP (CMX969P4), 24-pin SSOP (CMX969D5), and 24-pin TSSOP (CMX969E2) packages.

Radio Data-Link Access Procedure (RD-LAP) is a data communications air interface protocol developed by Motorola Inc.

MOTIENT is a registered service mark of the MOTIENT Company operating the MOTIENT Network. (Formerly known as American Mobile, operating the ARDIS Network).

DataTAC is a registered trademark of Motorola Inc.

CONTENTS

Section	Page
1 Block Diagram	4
2 Signal List	5
3 External Components	6
4 General Description	7
4.1 Description of Blocks	7
4.1.1 Data Bus Buffers	7
4.1.2 Address and R/W Decode	7
4.1.3 Status and Data Quality Registers	7
4.1.4 Command, Mode and Control Registers	7
4.1.5 Data Buffer	7
4.1.6 CRC Generator/Checker	7
4.1.7 FEC Encoder/Decoder	7
4.1.8 Interleave/De-interleave Buffer	8
4.1.9 Auto Frame Sync Detect, Rx Level & Timing Extraction, Rx Data Symbol Extraction	8
4.1.10 Rx Input Amp	8
4.1.11 Low Pass Filter	8
4.1.12 Tx Output Buffer	8
4.1.13 Clock Oscillator and Dividers	8
4.2 Modem - μ C Interaction	9
4.3 Binary to RD-LAP 4-Level Symbol Translation	9
4.4 Frame Structure	10
4.4.1 MDC Mode	10
4.4.2 RD-LAP Mode	11
4.5 The Programmer's View	12
4.5.1 Data Block Buffer	12
4.5.2 Control Register	12
4.5.3 Mode Register	13
4.5.4 Command Register	14
4.6 CMX969 Modem Tasks	16
4.6.1 Transmit Mode	16
4.6.2 Receive Mode:	19
4.6.3 Task Timings	22
4.6.4 Lowpass Filter Delay	24
4.6.5 Status Register	24
4.6.6 Data Quality Register	26

5	Application Notes	27
5.1	Autonomous Frame Sync Detect Function	27
5.2	Rx Control Procedure	28
6	Performance Specification	29
6.1	Electrical Performance	29
6.1.1	Absolute Maximum Ratings	29
6.1.2	Operating Limits.....	29
6.1.3	Operating Characteristics	30
6.2	Packaging	34

MX-COM, Inc. reserves the right to change specifications at any time and without notice.

1 Block Diagram

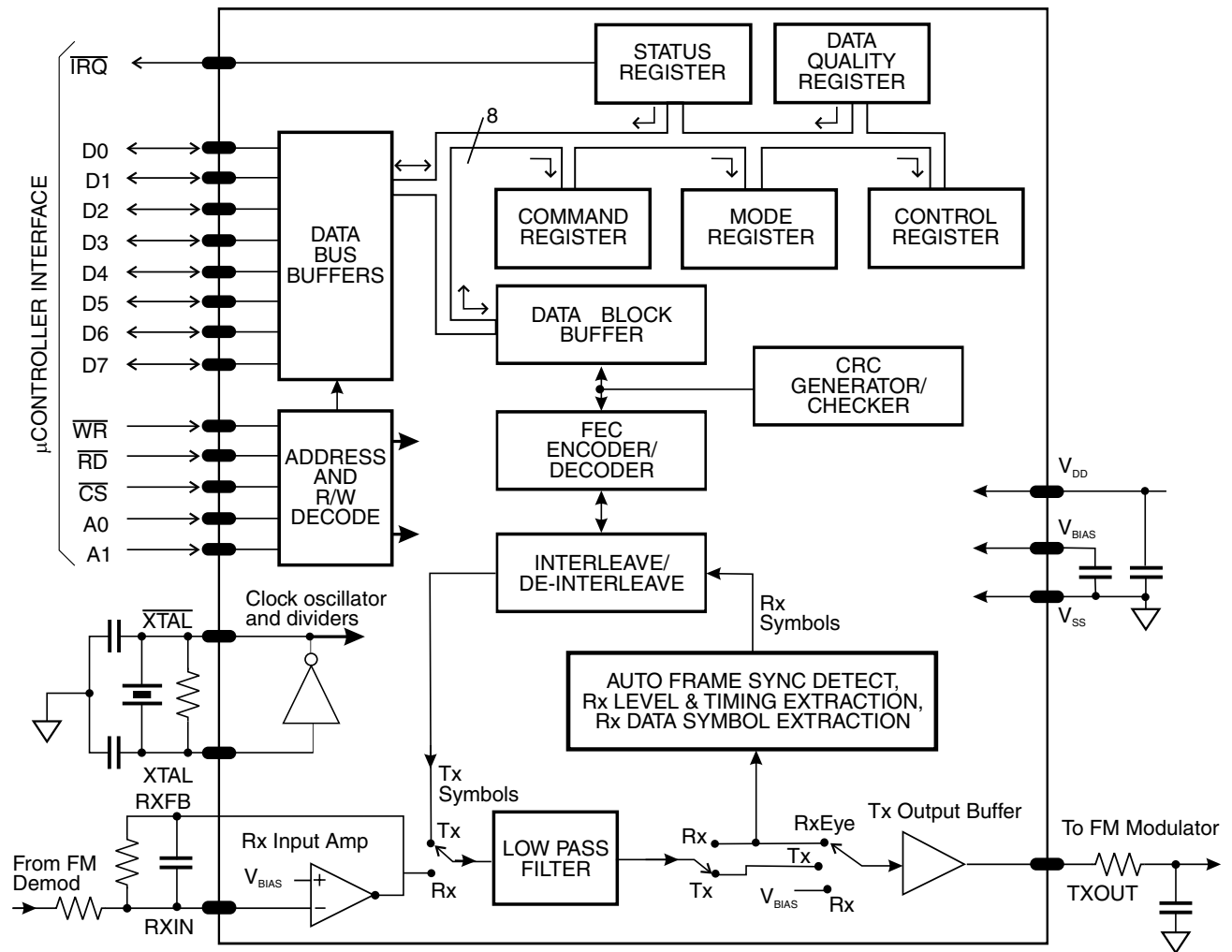

Figure 1: Block Diagram

2 Signal List

Package P4/E2/D5	Signal		Description
Pin No.	Name	Type	
1	$\overline{\text{IRQ}}$	output	A 'wire-ORable' output for connection to the host μC 's Interrupt Request input. This output has a low impedance pull down to V_{SS} when active and is high impedance when inactive.
2	D7	bi-directional	8-bit bi-directional 3-state μC interface data lines.
3	D6	bi-directional	
4	D5	bi-directional	
5	D4	bi-directional	
6	D3	bi-directional	
7	D2	bi-directional	
8	D1	bi-directional	
9	D0	bi-directional	
10	$\overline{\text{RD}}$	input	Read: An active low logic level input used to control the reading of data from the modem into the host μC .
11	$\overline{\text{WR}}$	input	Write: An active low logic level input used to control the writing of data into the modem from the host μC .
12	V_{SS}	power	The negative supply rail (ground).
13	$\overline{\text{CS}}$	input	Chip Select: An active low logic level input to the modem, used to enable a data read or write operation.
14	A0	input	Two logic level modem register select inputs.
15	A1	input	
16	$\overline{\text{XTAL}}$	output	The output of the on-chip oscillator.
17	XTAL	input	The input to the on-chip oscillator, for external Xtal circuit or clock.
18,19		NC	No connection should be made to these pins (reserved for possible future use)
20	TXOUT	output	The Tx signal output from the modem.
21	V_{BIAS}	output	A bias line for the internal circuitry, held at $V_{\text{DD}}/2$. This pin must be decoupled to V_{SS} by a capacitor mounted close to the device pins.
22	RXIN	input	The input to the Rx input amplifier.
23	RXFB	output	The output of the Rx input amplifier.
24	V_{DD}	power	The positive supply rail. Levels and voltages are dependent upon this supply. This pin should be decoupled to V_{SS} by a capacitor.

Table 1: Signal List

Note: Internal protection diodes are connected from each signal pin to V_{DD} and V_{SS} .

3 External Components

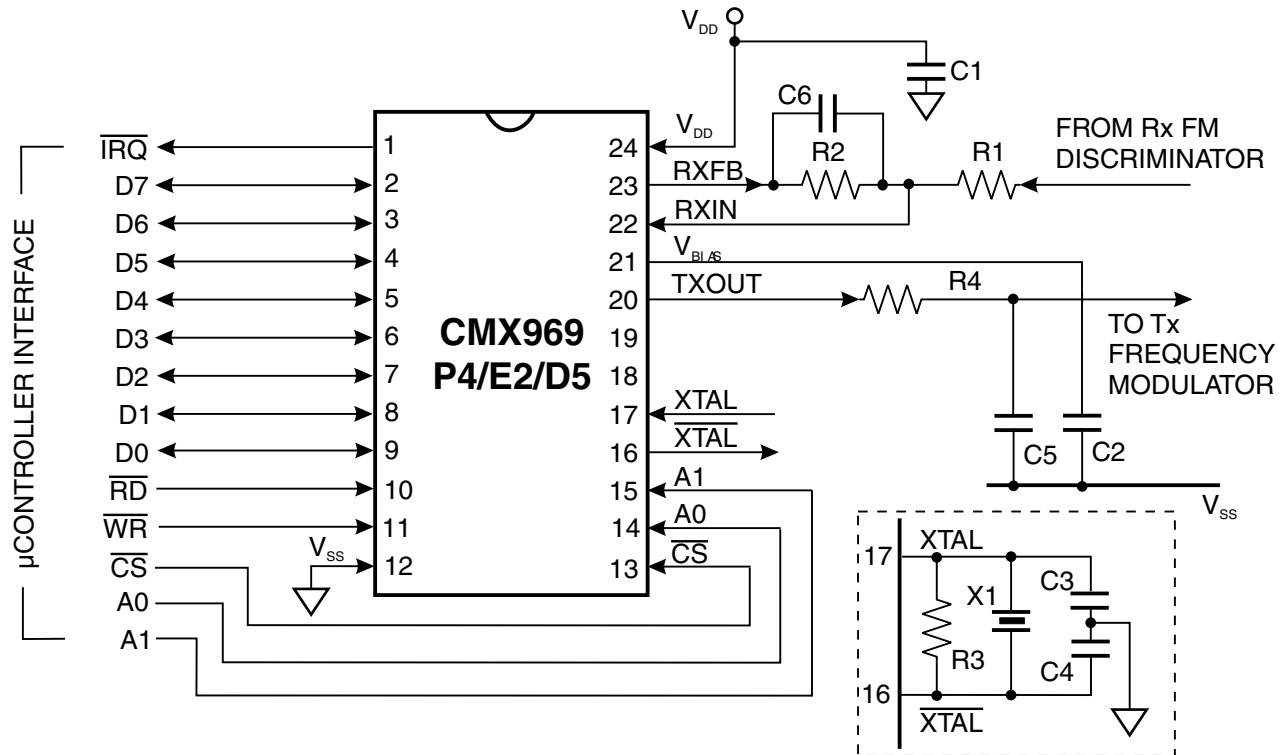

Figure 2: Recommended External Components

R1	See Section 4.1	C2	0.1 $\mu\text{F} \pm 20\%$
R2	100k $\Omega \pm 5\%$	C3	$\pm 20\%$, see Note 1
R3	1M $\Omega \pm 20\%$	C4	$\pm 20\%$, see Note 1
R4	100k $\Omega \pm 5\%$	C5	100pF $\pm 5\%$
C1	0.1 $\mu\text{F} \pm 20\%$	C6	100pF $\pm 5\%$
X1	4.9152, 7.3728 or 9.8304 MHz $\pm 100\text{ppm}$. See Section 4.5.2		

Table 2: Recommended External Components

Recommended External Component Notes:

1. The values used for C3 and C4 should be suitable for the frequency of the crystal X1. As a guide, values (including stray capacitances) of 33pF at 1MHz falling to 18pF at 10MHz will generally prove suitable.
2. For best results, a crystal oscillator design should drive the clock inverter input with signal levels of at least 40% of V_{DD} , peak to peak. Tuning fork crystals generally cannot meet this requirement. To obtain crystal oscillator design assistance, please consult your crystal manufacturer.

4 General Description

4.1 Description of Blocks

Refer to Figure 1.

4.1.1 Data Bus Buffers

Eight bi-directional 3-state logic level buffers between the modem's internal registers and the host μ C's data bus lines.

4.1.2 Address and R/W Decode

This block controls the transfer of data bytes between the μ C and the modem's internal registers, according to the state of the Write and Read Enable inputs (\overline{WR} and \overline{RD}), the Chip Select input (\overline{CS}) and the Register Address inputs A0 and A1.

The Data Bus Buffers, Address and R/W Decode blocks provide a byte-wide parallel μ C interface, which can be memory-mapped, as shown in Figure 3.

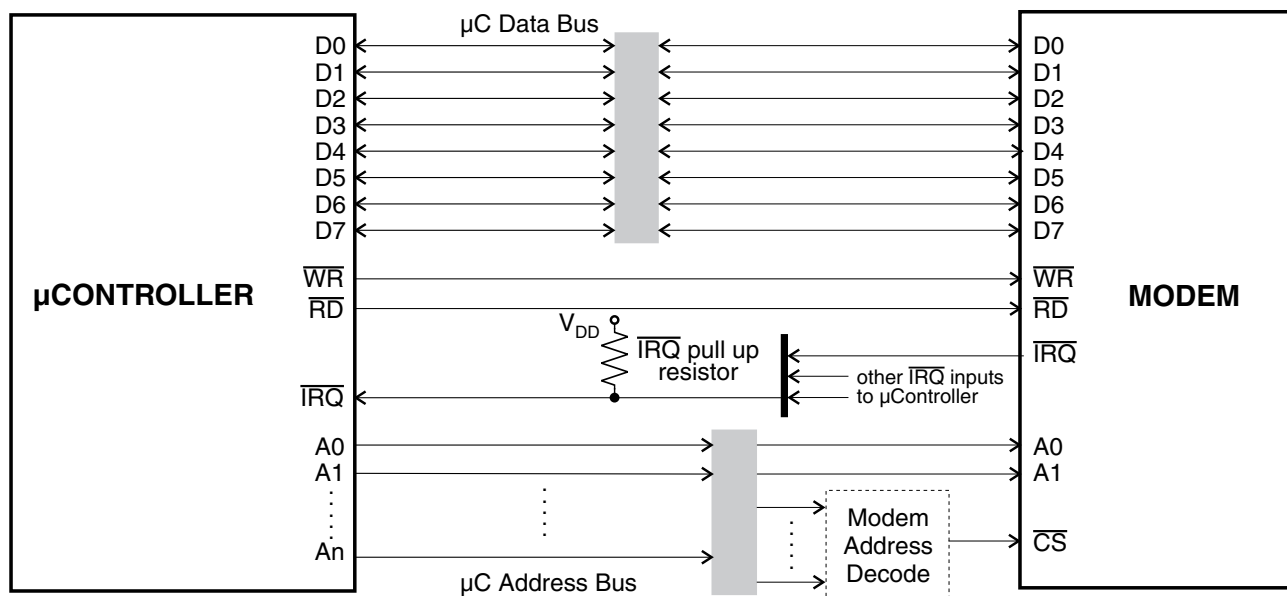

Figure 3: Typical Modem μ C Connections

4.1.3 Status and Data Quality Registers

Two 8-bit registers which the μ C can read to determine the status of the modem and the received data quality.

4.1.4 Command, Mode and Control Registers

The values written by the μ C to these 8-bit registers control the operation of the modem.

4.1.5 Data Buffer

A 12-byte buffer used to hold receive or transmit data to or from the μ C.

4.1.6 CRC Generator/Checker

A circuit which generates (in transmit mode) or checks (in receive mode) the Cyclic Redundancy Checksum bits, which are included in transmitted data blocks so that the receive modem can detect transmission errors.

4.1.7 FEC Encoder/Decoder

In transmit mode, this circuit adds Forward Error Correction information to the transmitted data. In RD-LAP mode it also converts the binary data to 4-level symbols. In receive mode, this block translates received symbols to binary data, using the FEC information to correct a large proportion of transmission errors.

4.1.8 Interleave/De-interleave Buffer

This circuit interleaves data symbols within a block before transmission and de-interleaves the received data so that the FEC system is best able to handle short noise bursts or fades.

4.1.9 Auto Frame Sync Detect, Rx Level & Timing Extraction, Rx Data Symbol Extraction

This block, which is only active in receive mode, is used to look for the Frame Synchronization pattern which is transmitted to mark the start of every frame and to extract the received symbols from the received signal using extracted signal level and timing information.

4.1.10 Rx Input Amp

This amplifier allows the received signal input to the modem to be set to the optimum level by suitable selection of the external components R1 and R2. The dc level of the received signal should be adjusted so that the signal at the modem's RXFB pin is centered around V_{BIAS} ($V_{DD}/2$). See Section 6.1.3 for details of the optimum levels.

4.1.11 Low Pass Filter

This filter, which is used in both transmit and receive modes, is a linear-phase low pass filter having a frequency response automatically switched to suit RD-LAP or MDC operation.

In transmit mode, the data symbols are passed through this filter to eliminate the high frequency components that would otherwise cause interference into adjacent radio channels.

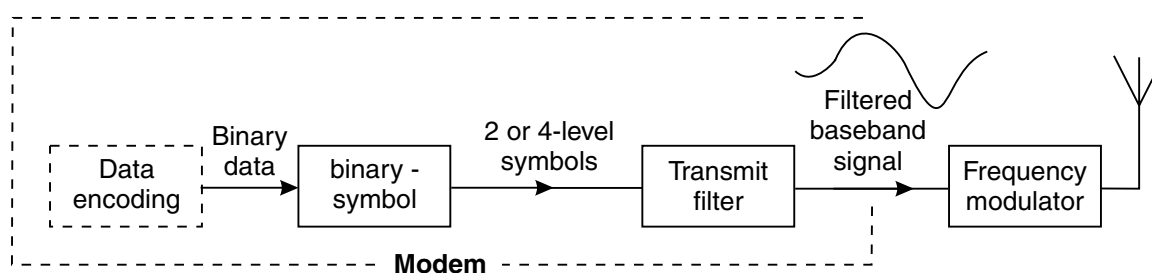

Figure 4: Generation of Filtered Tx Baseband Signal

In receive mode, the filter is used to reject HF noise and to equalize the received signal to a form suitable for extracting the received data.

4.1.12 Tx Output Buffer

This is a unity gain amplifier used in transmit mode to buffer the output of the Tx low pass filter. In receive mode, the input of this buffer is connected to V_{BIAS} unless the RXEYE bit of the Control Register is '1', when it is connected to the received signal. When changing from Rx to Tx mode the input to this buffer will be connected to V_{BIAS} for 8 symbol times in RD-LAP mode, 2 symbol times in MDC mode, while the low pass filter settles.

Note: The RC low pass filter formed by the external components R4 and C5 between the TXOUT pin and the input to the radio's frequency modulator forms an important part of the transmit out of band spurious signal filtering. These components may form part of any dc level-shifting and gain adjustment circuitry. C5 should be positioned to give maximum attenuation of high frequency noise into the modulator.

4.1.13 Clock Oscillator and Dividers

These circuits derive the transmit symbol rate (and the nominal receive symbol rate) by frequency division of a reference frequency which may be generated by the on-chip Xtal oscillator or applied from an external source.

Note: If the on-chip xtal oscillator is to be used, then the external components X1, C3, C4 and R3 are required. If an external clock source is to be used, then it should be connected to the XTAL input pin, the XTAL pin should be left unconnected, and X1, C3, C4 and R3 not fitted.

4.2 Modem - μ C Interaction

In general, data is transmitted over-air in the form of messages, or 'Frames', consisting of a 'Frame Preamble' followed by one or more formatted data blocks. The Frame Preamble includes a Frame Synchronization pattern designed to allow the receiving modem to identify the start of a frame. The following data blocks are constructed from the 'raw' data using a combination of CRC (cyclic redundancy checksum) generation, Forward Error Correction coding and Interleaving. Details of the message formats handled by the modem are given in Section 4.4 and Figure 5 and Figure 6.

To reduce the processing load on the associated μ C, the CMX969 modem has been designed to perform as much as possible of the computationally intensive work involved in Frame formatting and de-formatting and - when in receive mode - in searching for and synchronizing onto the Frame Preamble. In normal operation the modem will only require servicing by the μ C once per received or transmitted block.

Thus, to transmit a block, the controlling μ C has only to load the - unformatted - 'raw' binary data into the modem's Data Block Buffer then instruct the modem to format and transmit that data. The modem will then calculate and add the CRC bits as required, encode the result as 2 or 4-level symbols (with Forward Error Correction coding) and interleave the symbols before transmission.

In receive mode, the modem can be instructed to assemble a block's worth of received symbols, de-interleave the symbols, translate them to binary - using the FEC coding to correct as many errors as possible - and check the resulting CRC before placing the received binary data into the Data Block Buffer for the μ C to read.

The modem can also transmit and receive un-formatted data using the T4S, T24S, R4S, T8B, T40B and R8B tasks described in Section 4.5.4. These are normally used for the transmission of Symbol and Frame Synchronization sequences. They may also be used for the transmission and reception of special test patterns.

4.3 Binary to RD-LAP 4-Level Symbol Translation

Although the over-air signal, and hence the signals at the modem TXOUT and RXIN pins, consists of 4-level symbols in RD-LAP mode, the raw data passing between the modem and the μ C is in binary form. Translation between binary data and the 4-level symbols is done in one of two ways, depending on the task being performed.

Direct: the simplest form, which converts between 2 binary bits and a single symbol, such as the 'S' Channel Status symbol.

Symbol	MSB	LSB
+3	1	1
+1	1	0
-1	0	0
-3	0	1

This is expanded so that an 8-bit byte translates to four symbols for the T4S, T24S and R4S tasks described in Section 4.5.2.

	MSB				LSB			
Bits:	7	6	5	4	3	2	1	0
Symbols:	a		b		c		d	
	sent first				sent last			

With FEC: This is more complicated, but essentially translates groups of 3 binary bits to pairs of 4-level symbols using a Forward Error Correcting coding scheme for the block oriented tasks THB, TIB, TLB, TSID, RHB, RILB and RSID described in Section 4.5.4.

4.4 Frame Structure

In both RD-LAP and MDC modes the CMX969 performs all of the block formatting and de-formatting, the binary data transferred between the modem and its μ C being that enclosed by the thick dashed rectangles near the top of Figure 5 and Figure 6.

4.4.1 MDC Mode

The CMX969 Frame Structure in MDC mode is illustrated in Figure 5, and consists of a Frame Synchronization pattern followed by one or more 'Header' blocks, one or more 'Intermediate' blocks and a 'Last' block. Channel Status bits are included at regular intervals. The first Frame of any transmission is preceded by a Bit Synchronization pattern.

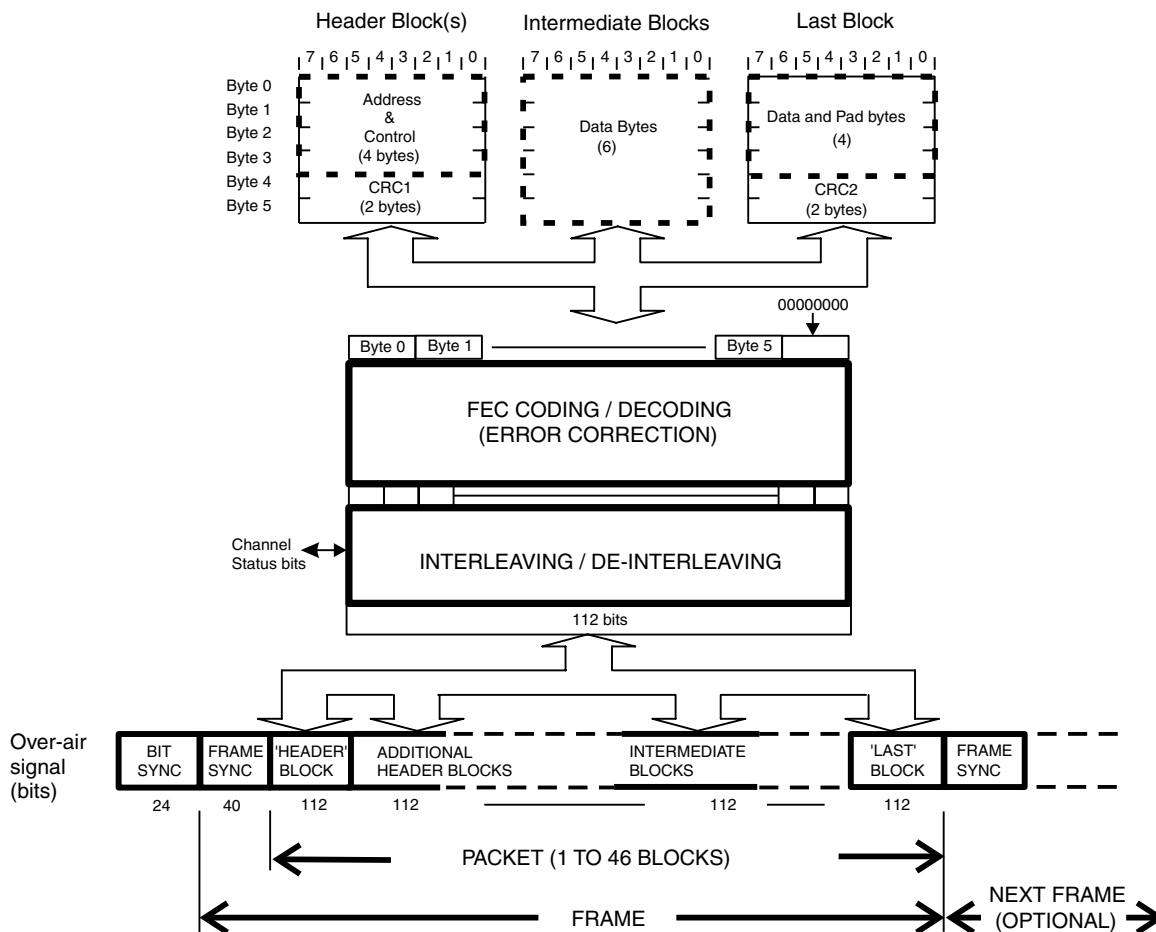

Figure 5: MDC Over Air Signal Format

4.4.2 RD-LAP Mode

The CMX969 Frame Structure in RD-LAP mode is illustrated in Figure 6, and consists of a Frame Preamble (comprising a 24-symbol Frame Synchronization pattern and Station ID block) followed by one or more 'Header' blocks, one or more 'Intermediate' blocks and a 'Last' block. Channel Status (S) symbols are included at regular intervals. The first Frame of any transmission is preceded by a Symbol Synchronization pattern.

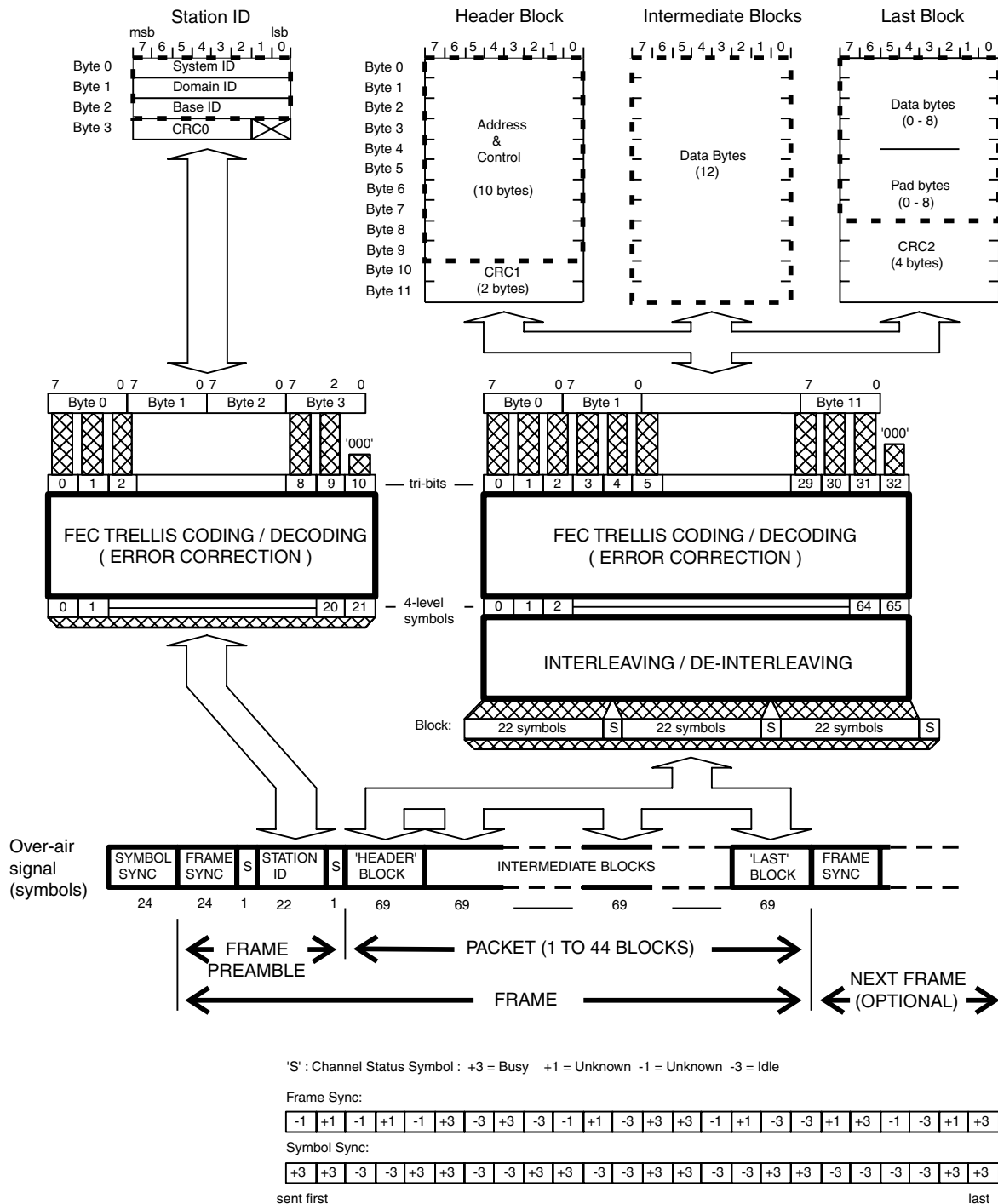

Figure 6: RD-LAP Over Air Signal Format

4.5 The Programmer's View

The modem appears to the programmer as 4 write only 8-bit registers shadowed by 3 read only registers, individual registers being selected by the A0 and A1 chip inputs: Note that there is a minimum allowable time between accesses of the modem's registers, see Section 6.1 for details.

A1	A0	Write to Modem	Read from Modem
0	0	Data Buffer	Data Buffer
0	1	Command Register	Status Register
1	0	Control Register	Data Quality Register
1	1	Mode Register	Reserved for other uses.

4.5.1 Data Block Buffer

This is a 12-byte read/write buffer that is used to transfer data (as opposed to command, status, mode, data quality or control information) between the modem and the host μ C. It appears to the μ C as a single 8-bit register; the modem ensuring that sequential μ C reads or writes to the buffer are routed to the correct locations within the buffer.

The μ C should only access this buffer when the Status Register BFREE (Buffer Free) bit is '1'.

The buffer should only be written to while in Tx mode and read from while in Rx mode. Note that in receive mode the modem will function correctly even if the μ C does not read the received data from the Data Buffer.

4.5.2 Control Register

This 8-bit write-only register controls the modem's operating mode (RD-LAP or MDC), symbol rate and the response times of the receive clock extraction and signal level measurement circuits.

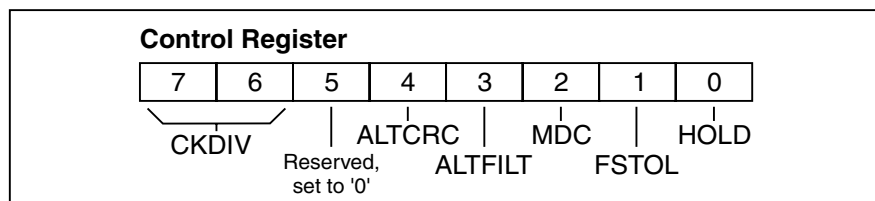

4.5.2.1 Control Register B7, B6: CKDIV - Clock Division Ratio

These bits control a frequency divider driven from the clock signal present at the $\overline{\text{XTAL}}$ pin, and hence determine the nominal symbol and bit rates. The following table shows the settings of B7 and B6 needed for 19200bps RD-LAP and 4800bps MDC4800 operation.

B7	B6	Xtal Frequency	Division ratio:	
			Xtal frequency / RD-LAP Symbol Rate	Xtal frequency / MDC4800 Symbol Rate
0	0	4.9152 MHz	512	1024
0	1	7.3728 MHz	768	1536
1	0	9.8304 MHz	1024	2048
1	1	See note	1536	3072

Note: The setting B7 = 1 and B6 = 1 cannot be used with 19200bps RD-LAP / 4800bps MDC4800 as this would require a Xtal frequency above the oscillator operating range.

The CMX969 may also be used with a 9600bps RD-LAP system if the Xtal frequency is 4.9152 or 7.3728MHz and Control register bits 7-6 set to '1 0' or '1 1'

4.5.2.2 Control Register B5: Reserved for future use.

This bit should always be set to '0'.

4.5.2.3 Control Register B4: ALTCRC - Alternative CRC

This bit should always be set to '0' for standard RD-LAP and MDC systems. Setting it to '1' in RD-LAP mode selects an alternative CRC generation/checking algorithm.

4.5.2.4 Control Register B3: ALTFILT - Alternative Filtering

This bit should always be set to '0' for standard RD-LAP and MDC systems. Setting it to '1' in RD-LAP mode selects slightly different transmit and receive lowpass filter characteristics more suitable for some non-standard systems.

4.5.2.5 Control Register B2: MDC - MDC Mode

If this bit is '0' the CMX969 operates in RD-LAP mode, setting this bit to '1' selects MDC mode. Changing between RD-LAP and MDC modes will cancel any current task.

4.5.2.6 Control Register B1: FSTOL - Frame Sync Detect Tolerance

In RD-LAP mode, this bit affects the number of errors tolerated by the Frame Sync detector. The allowable errors are approximately 3 bits when FSTOL = 0, 7 bits when FSTOL = 1. In MDC mode, this bit has no effect and the Frame Sync detector will accept up to 5 incorrect bits in a received Frame Sync pattern.

4.5.2.7 Control Register B0: HOLD - Freeze Rx Level and Timing Corrections

Setting this bit to 1 disables the receive level and symbol timing error correction circuits.

4.5.3 Mode Register

The contents of this 8-bit write only register control the basic operating modes of the modem:

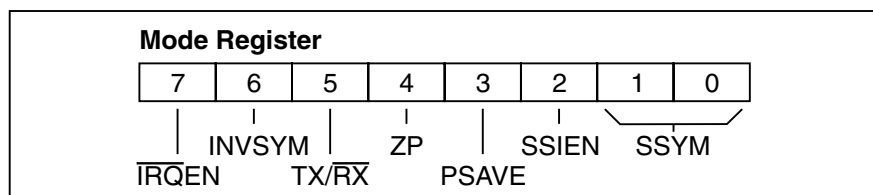

4.5.3.4 Mode Register B4: ZP - Zero Power

Setting this bit to '1' removes power from all of the CMX969's circuitry, including the Xtal oscillator, the V_{BIAS} supply and the Tx output buffer. The μC interface will continue to operate except for the Command Register which will not recognize or execute commands when ZP is '1' as it relies on a clock source for correct operation.

To obtain the lowest power consumption in Zero-Power mode, the Mode Register TX/RX bit (B5) should be set to 0 when the ZP bit (B4) is set to '1'.

4.5.3.5 Mode Register B3: PSAVE - Powersave

When this bit is a '1', the modem will be in a 'powersave' mode in which the internal filters, the Rx Symbol and Clock extraction circuits and the Tx output buffer will be disabled, and the TXOUT pin will be connected to V_{BIAS} through a high value resistance. The Xtal Clock oscillator, Rx input amplifier and the μC interface logic will continue to operate.

Setting the PSAVE bit to '0' when the ZP bit is '0' restores power to all of the chip circuitry. Note that the internal filters - and hence the TXOUT pin in transmit mode - will take about 20 symbol-times to settle after the PSAVE bit is taken from '1' to '0'.

4.5.3.6 Mode Register B2: SSIEN - 'S' Symbol IRQ Enable

In receive mode, setting this bit to '1' causes the IRQ bit of the status register to be set to '1' whenever a new channel status 'S' symbol has been received. (The SRDY bit of the Status Register will also be set to '1' at the same time, and the SVAL bits updated to reflect the received 'S' symbol.)

In transmit mode, setting this bit to '1' causes the IRQ bit of the Status Register to be set to '1' whenever a 'S' symbol or channel status bit has been transmitted. (The SRDY bit of the Status Register will also be set to '1' at the same time.)

In MDC mode, no interrupt is generated for the unused '94th' bit in each block.

4.5.3.7 Mode Register B1, 0: SSYM - 'S' Symbol To Be Transmitted

In transmit mode these two bits define the next 'S' symbol or channel status bit to be transmitted. These bits have no effect in receive mode.

B1	B0	RD-LAP	MDC
1	1	'+3'	'+1'
1	0	'+1'	'+1'
0	0	'-1'	'-1'
0	1	'-3'	'-1'

4.5.4 Command Register

Writing to this register tells the modem to perform a specific action or actions, depending on the setting of the AFSD and TASK bits, and controls the RxEye function.

Note: The Command Register uses internal clocks derived from the XTAL input to decode and carry out any task written to it. To allow time for the Xtal oscillator to start up, it is advisable to postpone writing to the Command Register until about 20ms after power is applied to the CMX969 or the Mode Register ZP bit is changed from '1' to '0'.

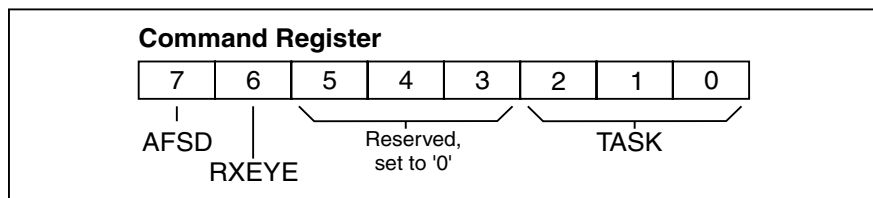

When it has no action to perform, the modem will be in an 'idle' state. If the modem is in transmit mode the input to the Tx filter will be connected to V_{BIAS} . In receive mode the modem will continue to measure the received data quality and extract symbols from the received signal, supplying them to the de-interleave buffer, but will otherwise ignore the received data.

4.5.4.1 Command Register B7: AFSD - Autonomous Frame Sync Detect

Setting this bit to '1' in receive mode enables the Autonomous Frame Sync Detect function. It has no effect in transmit mode.

4.5.4.2 Command Register B6: RXEYE - Show Rx Eye

This bit should normally be set to '0'.

Setting it to '1' when the modem is in receive mode connects the input of the Tx output buffer to the Rx filter output (see Figure 1). This allows the filtered and equalized receive signal to be monitored with an oscilloscope (at the TXOUT pin itself), to assess the quality of the complete radio channel including the Tx and Rx modem filters, the Tx modulator and the Rx IF filters and FM demodulator. In transmit mode this bit has no effect.

In RD-LAP mode the resulting eye diagram (for reasonably random data) should ideally be as shown in Figure 7, with 4 'crisp' and equally spaced crossing points.

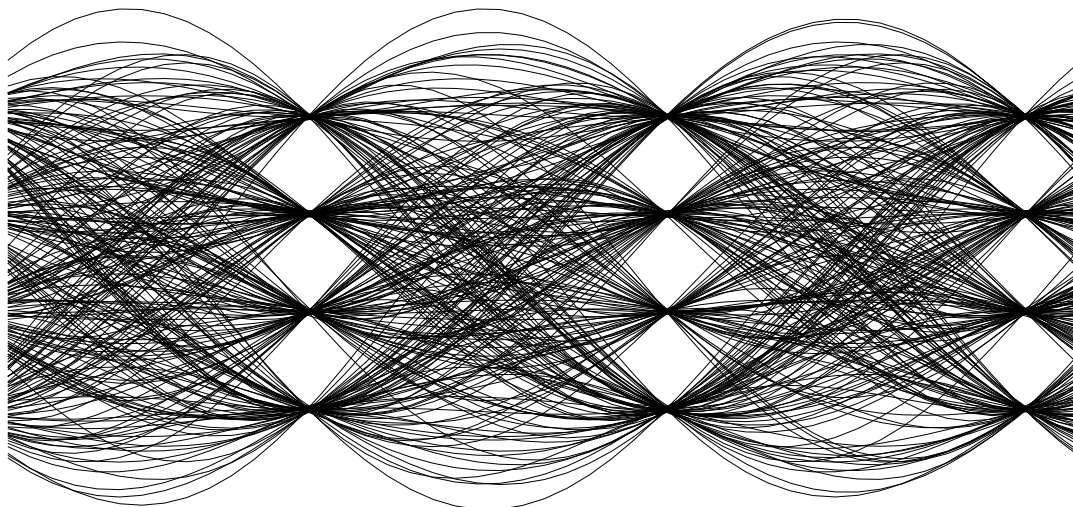

Figure 7: Ideal 'RXEYE' Signal: RD-LAP Mode

In MDC mode the eye diagram should be as shown in Figure 8.

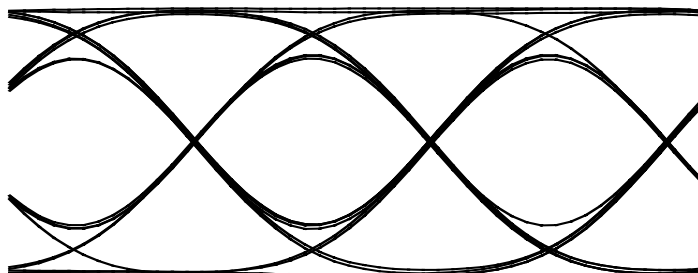

Figure 8: Ideal 'RXEYE' Signal: MDC Mode

4.5.4.3 Command Register B5-3

These bits are reserved for future use and should always be set to '0'.

4.5.4.4 Command Register B2, B1, B0: TASK

Operations such as transmitting or receiving a data block are treated by the modem as 'tasks' and are initiated when the μ C writes a byte to the Command Register with the TASK bits set to anything other than the 'NULL' code.

The μ C should not write a task (other than NULL or RESET) to the Command Register or write to or read from the Data Buffer when the BFREE (Buffer Free) bit of the Status Register is '0'.

Different tasks apply in RD-LAP and MDC receive and transmit modes.

4.6 CMX969 Modem Tasks

4.6.1 Transmit Mode

B2	B1	B0	RD-LAP		MDC	
0	0	0	NULL		NULL	
0	0	1	T24S	Transmit 24 symbols	T40B	Transmit 40 bits
0	1	0	THB	Transmit Header Block	THB	Transmit Header Block
0	1	1	TIB	Transmit Intermediate Block	TIB	Transmit Intermediate Block
1	0	0	TLB	Transmit Last Block	TLB	Transmit Last Block
1	0	1	T4S	Transmit 4 symbols	T8B	Transmit 8 bits
1	1	0	TSID	Transmit Station ID	-	Unused
1	1	1	RESET	Cancel any current action	RESET	Cancel any current action

When the modem is in transmit mode, all tasks other than NULL or RESET instruct the modem to transmit data from the Data Buffer, formatting it as required. The μ C should therefore wait until the BFREE (Buffer Free) bit of the Status Register is '1', before writing the data to the Data Block Buffer, then it should write the desired task to the Command Register. If more than 1 byte needs to be written to the Data Block Buffer, byte number 0 of the block should be written first.

Once the byte containing the desired task has been written to the Command Register, the modem will:

Set the BFREE (Buffer Free) bit of the Status Register to '0'.

Take the data from the Data Block Buffer as quickly as it can - transferring it to the Interleave Buffer for eventual transmission. This operation will start immediately if the modem is 'idle' (i.e. not transmitting data from a previous task), otherwise it will be delayed until there is sufficient room in the Interleave Buffer.

Once all of the data has been transferred from the Data Block Buffer, the modem will set the BFREE and IRQ bits of the Status Register to '1' (causing the chip $\overline{\text{IRQ}}$ output to go low if the $\overline{\text{IRQEN}}$ bit of the Mode Register has been set to '1'). This tells the μ C that it may write new data and the next task to the modem.

This lets the μ C write a task and the associated data to the modem while the modem is still transmitting the data from the previous task.

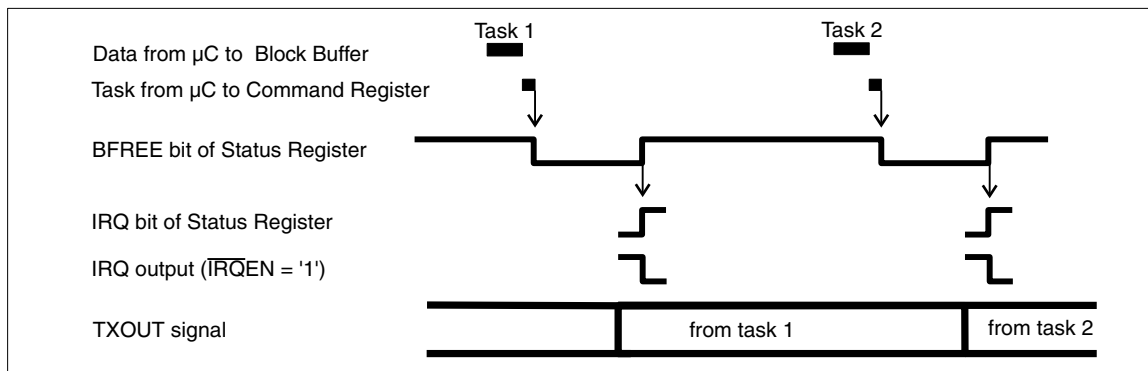

Figure 9: Transmit Task Overlapping

4.6.1.1 T24S: Transmit 24 Symbols (RD-LAP only)

This task, which is intended to facilitate the transmission of Symbol and Frame Sync patterns as well as special test sequences, takes 6 bytes of data from the Data Block Buffer and transmits them as 24 4-level symbols without any CRC, FEC, interleaving or adding any 'S' symbols.

Byte 0 of the Data Block Buffer is sent first, byte 5 last.

Once the modem has read the data bytes from the Data Block Buffer, the BFREE and IRQ bits of the Status Register will be set to '1', indicating to the μ C that it may write the data and command byte for the next task to the modem.

The following tables show what data has to be written to the Data Block Buffer to transmit the CMX969 Symbol and Frame Sync sequences:

'Symbol Sync' Symbols				Values written to Data Block Buffer		
					Binary	Hex
+3	+3	-3	-3	Byte 0:	11110101	F5
+3	+3	-3	-3	Byte 1:	11110101	F5
+3	+3	-3	-3	Byte 2:	11110101	F5
+3	+3	-3	-3	Byte 3:	11110101	F5
+3	+3	-3	-3	Byte 4:	11110101	F5
-3	-3	+3	+3	Byte 5 :	01011111	5F

'Frame Sync' Symbols				Values written to Data Block Buffer		
					Binary	Hex
-1	+1	-1	+1	Byte 0:	00100010	22
-1	+3	-3	+3	Byte 1:	00110111	37
-3	-1	+1	-3	Byte 2:	01001001	49
+3	+3	-1	+1	Byte 3:	11110010	F2
-3	-3	+1	+3	Byte 4:	01011011	5B
-1	-3	+1	+3	Byte 5:	00011011	1B

4.6.1.2 NULL:

This 'task' has no effect in transmit mode.

4.6.1.3 T40B: Transmit 40 Bits (MDC only)

This task is similar to the RD-LAP mode T24S task, but transmits 40 bits taken from the first 5 bytes in the Data Block Buffer. Data block buffer byte 0 is transmitted first, byte 4 last, within each byte the MSB is transmitted first, LSB last. (See Section 4.6.5.8)

4.6.1.4 THB: Transmit Header Block (RD-LAP and MDC)

In RD-LAP mode this task takes 10 bytes of data from the Data Block Buffer, calculates and appends the 2-byte CRC1 checksum, translates the result to 4-level symbols (with FEC), interleaves the symbols and transmits the result as a formatted 'Header' Block, inserting 'S' symbols at 22-symbol intervals.

In MDC mode this task takes 4 bytes of data from the Data Block Buffer, calculates and appends the 2-byte checksum, adds FEC bits, interleaves the result, inserts channel status bits and transmits the result as a formatted 'Header' Block.

Once the modem has read the data bytes from the Data Block Buffer, the BFREE and IRQ bits of the Status Register will be set to '1'.

4.6.1.5 TIB: Transmit Intermediate Block (RD-LAP and MDC)

In RD-LAP mode this task takes 12 bytes of data from the Data Block Buffer, updates the 4-byte CRC2 checksum for inclusion in the 'Last' block, translates the 12 data bytes to 4-level symbols (with FEC), interleaves the symbols and transmits the result as a formatted 'Intermediate' Block, inserting 'S' symbols at 22-symbol intervals.

In MDC mode this task takes 6 bytes of data from the Data Block Buffer, updates the 2-byte CRC checksum for inclusion in the 'Last' block, adds FEC bits, interleaves the result, inserts channel status bits and transmits the result as a formatted 'Intermediate' Block.

Once the modem has read the data bytes from the Data Block Buffer, the BFREE and IRQ bits of the Status Register will be set to '1'.

4.6.1.6 TLB: Transmit Last Block (RD-LAP and MDC)

In RD-LAP mode this task takes 8 bytes of data from the Data Block Buffer, updates and appends the 4-byte CRC2 checksum, translates the resulting 12 bytes to 4-level symbols (with FEC), interleaves the symbols and transmits the result as a formatted 'Last' Block, inserting 'S' symbols at 22-symbol intervals.

In MDC mode this task takes 4 bytes of data from the Data Block Buffer, updates and appends the 2-byte checksum, adds FEC bits, interleaves the result, inserts channel status bits and transmits the result as a formatted 'Last' Block.

Once the modem has read the data bytes from the Data Block Buffer, the BFREE and IRQ bits of the Status Register will be set to '1'.

4.6.1.7 T4S: Transmit 4 Symbols (RD-LAP only)

This task is similar to T24S but takes only one byte from the Data Block Buffer, transmitting it as four 4-level symbols most significant bit first.

4.6.1.8 T8B: Transmit 8 Bits (MDC only)

This task is similar to T40B but takes only one byte from the Data Block Buffer, transmitting it as 8 bits.

4.6.1.9 TSID: Transmit Station ID (RD-LAP only)

This task takes 3 ID bytes from the Data Block Buffer, calculates and appends the 6-bit CRC0 checksum, translates the result to 4-level symbols (with FEC) and transmits the resulting 22 symbols preceded and followed by 'S' symbols.

Once the modem has read the data bytes from the Data Block Buffer, the BFREE and IRQ bits of the Status Register will be set to '1'.

4.6.1.10 RESET: Stop any current action

This 'task' takes effect immediately, and terminates any current task the modem may be performing and sets the BFREE bit of the Status Register to '1', without setting the IRQ bit. It should be used (after a delay to allow the Xtal oscillator to start up) when V_{DD} is applied or the ZP bit of the Mode Register changed from '1' to '0' to set the modem into a known state.

Note that due to delays in the transmit low pass filter, it will take several symbol times for any change to appear at the TXOUT pin.

4.6.2 Receive Mode:

B2	B1	B0	RD-LAP		MDC	
0	0	0	NULL		NULL	
0	0	1	SFP	Search for Frame Preamble	-	Unused
0	1	0	RHB	Read Header Block	RHB	Read Header Block
0	1	1	RILB	Read Intermediate or Last Block	RILB	Read Intermediate or Last Block
1	0	0	SFS	Search for Frame Sync	SFS	Search for Frame Sync
1	0	1	R4S	Read 4 symbols	R8B	Read 8 bits
1	1	0	RSID	Read Station ID	-	Unused
1	1	1	RESET	Cancel any current action	RESET	Cancel any current action

When the modem is in receive mode, the μC should wait until the BFREE bit of the Status Register is '1', then write the desired task to the Command Register.

Once the byte containing the desired task has been written to the Command Register, the modem will:

Set the BFREE bit of the Status Register to '0'.

Wait until enough received symbols are in the De-interleave Buffer.

Decode them as needed, and transfer the resulting binary data to the Data Block Buffer

Then the modem will set the BFREE and IRQ bits of the Status Register to '1', (causing the $\overline{\text{IRQ}}$ output to go low if the $\overline{\text{IRQEN}}$ bit of the Mode Register has been set to '1') to tell the μC that it may read from the Data Block Buffer and write the next task to the modem. If more than 1 byte is contained in the buffer, byte number 0 of the data will be read out first.

In this way, the μC can read data and write a new task to the modem while the received symbols needed for this new task are being received and stored in the De-interleave Buffer.

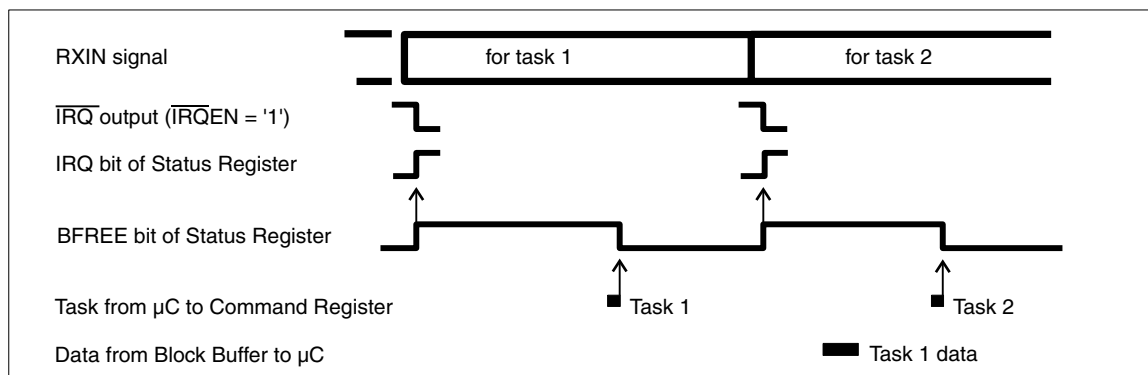

Figure 10: Receive Task Overlapping

Detailed timings for the various tasks are given in Figure 11 and Figure 12.

4.6.2.1 NULL:

This 'task' allows the AFSD or RXEYE bits to be changed without any other effect.

4.6.2.2 SFP: Search for Frame Preamble (RD-LAP only)

This task causes the modem to search the received signal for a valid Frame Preamble, consisting of a 24-symbol Frame Sync sequence followed by Station ID data, which has a correct CRC0 checksum.

The task continues until a valid Frame Preamble has been found.

The search consists of four stages:

First of all the modem will attempt to match the incoming symbols against the Frame Synchronization pattern

Once a match has been found, the modem will read in the following 'S' symbol, place it in the SVAL bits of the Status Register then set the SRDY bit to '1'. (The IRQ bit of the Status Register will also be set to '1' at this time if the SSIEN bit of the Mode Register is '1').

The modem will then read the next 22 symbols as station ID data. They will be decoded and the CRC0 checked. If this is incorrect, the modem will resume the search, looking for a fresh Frame Sync pattern.

If the received CRC0 is correct, the following 'S' symbol will be read into the SVAL bits of the Status Register and the SRDY, BFREE and IRQ bits set to '1', the CRCERR bit cleared to '0', and the three decoded Station ID bytes placed into the Data Block Buffer.

On detecting that the BFREE bit of the Status Register has gone to '1', the μ C should read the 3 Station ID bytes from the Data Block Buffer then write the next task to the modem's Command Register.

4.6.2.3 RHB: Read Header Block (RD-LAP and MDC)

In RD-LAP mode, this task causes the modem to read the next 69 symbols as a 'Header' Block. It will strip out the 'S' symbols then de-interleave and decode the remaining 66 symbols, placing the resulting 10 data bytes and the 2 received CRC1 bytes into the Data Block Buffer, and setting the BFREE and IRQ bits of the Status Register to '1' when the task is complete to indicate that the μ C may read the data from the Data Block Buffer and write the next task to the modem's Command Register.

In MDC mode, this task causes the modem to read the next 112 bits as a 'Header' Block. It will strip out the channel status bits then de-interleave and decode the remaining bits, placing the resulting 4 data bytes and the 2 received CRC bytes into the Data Block Buffer, and setting the BFREE and IRQ bits of the Status Register to '1' when the task is complete to indicate that the μ C may read the data from the Data Block Buffer and write the next task to the modem's Command Register.

In both cases the CRCERR bit of the Status Register will be set to '1' or '0' depending on the validity of the received CRC checksum bytes.

As each of the 'S' symbols or channel status bits of a block is received, the SVAL bits of the Status Register will be updated and the SRDY bit set to '1'. (If the SSIEN bit of the Mode Register is '1', then the Status Register IRQ bit will also be set to '1'.) Note that when the third 'S' symbol is received in RD-LAP mode the SRDY bit will be set to '1' coincidentally with the BFREE bit also being set to '1'.

4.6.2.4 RILB: Read 'Intermediate' or 'Last' Block (RD-LAP and MDC)

This task causes the modem to read the next 69 symbols (RD-LAP) or 112 bits (MDC) as an 'Intermediate' or 'Last' block (the μ C can tell from the 'Header' block how many blocks are in the frame, and hence when to expect the 'Last' block).

In each case, it will strip out the 'S' symbols or channel status bits, de-interleave and decode the remaining symbols and place the resulting 12 (RD-LAP) or 6 (MDC) bytes into the Data Block Buffer, setting the BFREE and IRQ bits of the Status Register to '1' when the task is complete.

If an 'Intermediate' block is received then the μ C should read out all 12 or 6 bytes from the Data Block Buffer and ignore the CRCERR bit of the Status Register, for a 'Last' block the μ C need only read the first 8 or 4 bytes from the Data Block Buffer, and the CRCERR bit in the Status Register will reflect the validity of the received checksum.

As each of the 'S' symbols or channel status bits of the block is received, the SVAL bits of the Status Register will be updated and the SRDY bit set to '1'. (If the SSIEN bit of the Mode Register is '1', then the Status Register IRQ bit will also be set to '1'.) Note that when the third 'S' symbol is received in RD-LAP mode the SRDY bit will be set to '1' coincidentally with the BFREE bit also being set to '1'.

4.6.2.5 SFS: Search for Frame Sync (RD-LAP and MDC)

This task causes the modem to search the received signal for a 24-symbol (RD-LAP) or 40-bit (MDC) sequence which matches the required Frame Synchronization pattern(s). The allowable errors are described in Section 4.5.2.6.

In RD-LAP mode when a match is found the modem will read in the following 'S' symbol, then set the BFREE, IRQ and SRDY bits of the Status Register to '1' and update the SVAL bits. The μ C may then write the next task to the Command Register.

In MDC mode when a match is found the modem will set the BFREE, IRQ bits of the Status Register to '1' and set the FSTYPE bit according to the type of Frame Synchronization pattern received. The μ C may then write the next task to the Command Register.

4.6.2.6 R4S: Read 4 Symbols (RD-LAP only)

This task causes the modem to read the next 4 symbols and translate them directly (without de-interleaving or FEC) to an 8-bit byte which is placed into the Data Block Buffer. The BFREE and IRQ bits of the Status Register will then be set to '1' to indicate that the μ C may read the data byte from the Data Block Buffer and write the next task to the Command Register.

This task is intended for special tests and channel monitoring - perhaps preceded by SFS task.

Note that although it is possible to construct message formats which do not rely on the block formatting of the THB, TIB and TLB tasks by using T4S or T24S tasks to transmit and R4S to receive the user's data, anyone attempting this should be aware that the receive level and timing measurement circuits need to see a reasonably 'random' distribution of all four possible symbols in the received signal to operate correctly, and should therefore 'scramble' the binary data before transmission.

4.6.2.7 R8B: Read 8 Bits (MDC only)

This task reads the next 8 received bits and places the resulting 8-bit byte directly (without any attempt to de-interleave, remove channel status bits or apply FEC) into the Data Block Buffer. The BFREE and IRQ bits of the Status Register will then be set to '1' to indicate that the μ C may read the data byte from the Data Block Buffer and write the next task to the Command Register.

4.6.2.8 RSID: Read Station ID (RD-LAP only)

This task causes the modem to read in and decode the following 23 symbols as Station ID data followed by an 'S' symbol. It is similar to the last two parts of a SFP task except that it will not re-start if the received CRC0 is incorrect. It would normally follow a SFS task.

The 3 decoded bytes will be placed into the Data Block Buffer, and the CRCERR bit of the Status Register set to '1' if the received CRC0 was incorrect, otherwise it will be cleared to '0'. The SVAL bits of the Status Register will be updated and the BFREE, SRDY and IRQ bits set to '1' to indicate that the μ C may read the 3 received bytes from the Data Block Buffer and write the next task to the modem's Command Register.

4.6.3 Task Timings

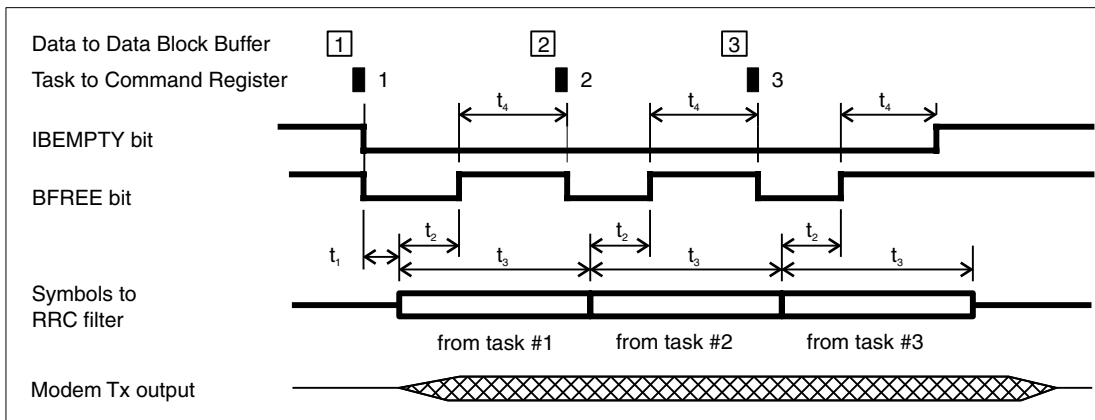

Figure 11: Transmit Task Timing Diagram

RD-LAP Transmit Task Timings		Task	Time (symbol times)
t_1	Modem in idle state. Time from writing first task to application of first transmit bit to Tx filter	Any	1 to 2
t_2	Time from application of first symbol of the task to the Tx filter until BFREE goes to a logic '1' (high).	T24S TSID THB/TIB/TLB T4S	5 6 16 0
t_3	Time to transmit all symbols of the task	T24S/TSID THB/TIB/TLB T4S	24 69 4
t_4	Max time allowed from BFREE going to a logic '1' (high) for next task (and data) to be written to modem	T24S TSID THB/TIB/TLB T4S	18 17 52 3

MDC Transmit Task Timings		Task	Time (bit times)
t_1	Modem in idle state. Time from writing first task to application of first transmit bit to Tx filter	Any	TBD
t_2	Time from application of first symbol of the task to the Tx filter until BFREE goes to a logic '1' (high).	T40B THB/TIB/TLB T8B	TBD TBD TBD
t_3	Time to transmit all symbols of the task	T40B THB/TIB/TLB T8B	TBD TBD TBD
t_4	Max time allowed from BFREE going to a logic '1' (high) for next task (and data) to be written to modem	T40B THB/TIB/TLB T8B	TBD TBD TBD

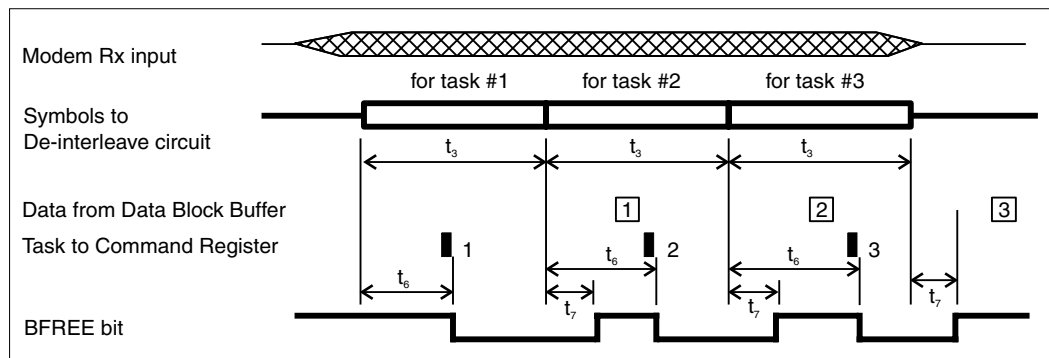

Figure 12: Receive Task Timing Diagram

RD-LAP Receive Task Timings		Task	Time (symbol times)
t_3	Time to receive all symbols of task	SFS SFP RSID RHB/RILB R4S	25 (minimum) 48 (minimum) 23 69 4
t_6	Maximum time between first symbol of task entering the de-interleave circuit and the task being written to modem.	SFS SFP RSID RHB/RILB R4S	21 21 15 51 3
t_7	Maximum time from the last bit of the task entering the de-interleave circuit to BFREE going to a logic '1' (high)	Any	1

MDC Receive Task Timings		Task	Time (symbol times)
t_3	Time to receive all symbols of task	SFS RHB/RILB R8B	TBD TBD TBD
t_6	Maximum time between first symbol of task entering the de-interleave circuit and the task being written to modem.	SFS RHB/RILB R8B	TBD TBD TBD
t_7	Maximum time from the last bit of the task entering the de-interleave circuit to BFREE going to a logic '1' (high)	Any	TBD

4.6.4 Lowpass Filter Delay

The previous task timing figures are based on the signal at the input to the low pass filter (in transmit mode) or the input to the de-interleave buffer (in receive mode). In RD-LAP mode there is an additional delay of about 8 symbol times through to the RRC filter in both transmit and receive modes, as illustrated below: The corresponding delay in MDC mode is about 3 symbol times.

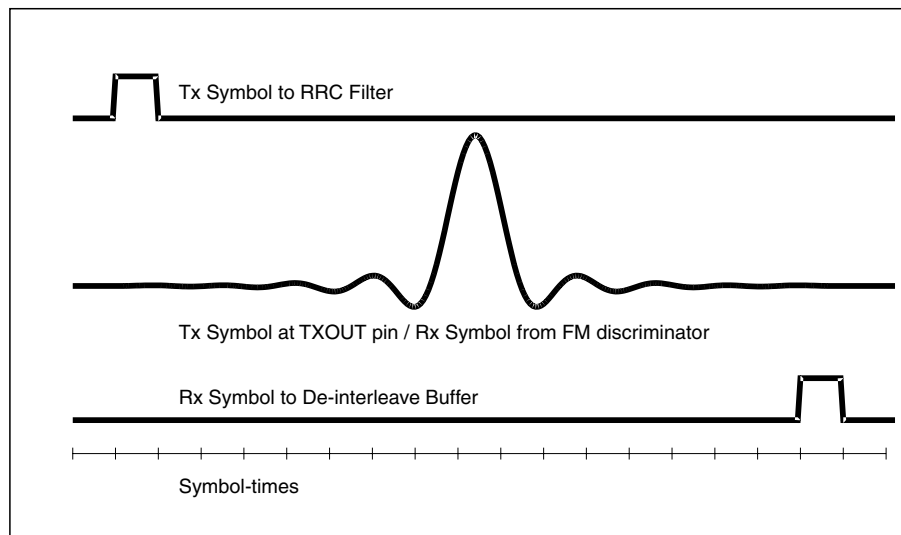
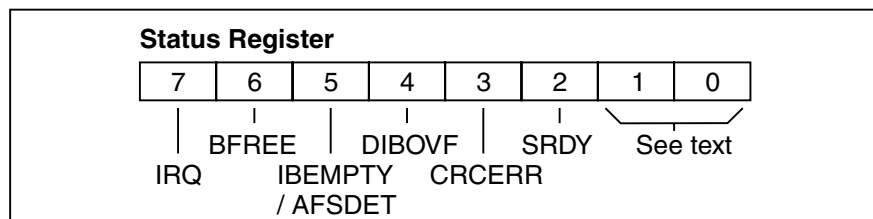

Figure 13: RRC Low Pass Filter Delay (RD-LAP mode)

4.6.5 Status Register

This register may be read by the μ C to determine the current state of the modem.



4.6.5.1 Status Register B7: IRQ - Interrupt Request

This bit is set to '1' by:

- The Status Register BFREE bit going from '0' to '1', unless this is caused by a RESET task or by a change to the Mode Register TX/RX, ZP or PSAVE bits.
- or* The Status Register IBEMPTY/AFSDET bit going from '0' to '1', unless this is caused by a RESET task or by changing the Mode Register TX/RX, ZP or PSAVE bits.
- or* The Status Register DIBOVF bit going from '0' to '1'.
- or* The Status Register SRDY bit being set to '1' (due to a 'S' symbol or channel status bit being received or transmitted) if the Mode Register SSIEN bit is '1'.

The IRQ bit is cleared to '0' immediately after a read of the Status Register.

If the $\overline{\text{IRQEN}}$ bit of the Mode Register is '1', then the chip $\overline{\text{IRQ}}$ output will be pulled low (to V_{SS}) whenever the IRQ bit is set to '1', and will go high impedance when the Status Register is read.

4.6.5.2 Status Register B6: BFREE - Data Block Buffer Free

This bit reflects the availability of the Data Block Buffer and is cleared to '0' whenever a task other than NULL or RESET is written to the Command Register.

In transmit mode, the BFREE bit will be set to '1' (also setting the Status Register IRQ bit to '1') by the modem when the modem is ready for the μ C to write new data to the Data Block Buffer and the next task to the Command Register.

In receive mode, the BFREE bit is set to '1' (also setting the Status Register IRQ bit to '1') by the modem when it has completed a task and any data associated with that task has been placed into the Data Block Buffer. The μ C may then read that data and write the next task to the Command Register.

The BFREE bit is also set to '1' - but without setting the IRQ bit - by a RESET task or when the Mode Register TX/RX, ZP or PSAVE bits are changed.

4.6.5.3 Status Register B5: IBEMPTY - Interleave Buffer Empty / AFSDET - Autonomous Frame Sync Detect

In transmit mode, this bit signals 'Interleave Buffer Empty' and will be set to '1' - also setting the IRQ bit - when less than two symbols remain in the Interleave Buffer. Any transmit task written to the modem after this bit goes to '1' will be too late to avoid a gap in the transmit output signal.

In transmit mode this bit is also set to '1' by a RESET task or by a change of the Mode Register TX/RX, ZP or PSAVE bits, but in these cases the IRQ bit will not be set.

In transmit mode this bit is cleared to '0' within one symbol time after a task other than NULL or RESET is written to the Command Register.

Note: When the modem is in transmit mode and the Interleave Buffer is empty, a mid level (half-way between '+1' and '-1') signal will be sent to the RRC filter.

In receive mode this bit is set to '1' - also setting the IRQ bit - when the Autonomous Frame Sync circuit is enabled (by setting b7 of the Command Register) and a received Frame Sync pattern is detected. The bit is cleared to '0' immediately after reading the Status Register. To avoid confusion this bit is not set when Frame Sync is detected as part of a RD-LAP SFP task.

In receive mode this bit is also cleared to '0' by a RESET task or by a change of the Mode Register TX/RX, ZP or PSAVE bits.

4.6.5.4 Status Register B4: DIBOVF - De-Interleave Buffer Overflow

In receive mode this bit will be set to '1' - also setting the IRQ bit - when a RHB, RILB, RSID, R8B or R4S task is written to the Command Register too late to allow continuous reception.

The bit is cleared to '0' immediately after reading the Status Register, by writing a RESET task to the Command Register or by changing the TX/RX, ZP or PSAVE bits of the Mode Register.

In transmit mode this bit is '0'.

4.6.5.5 Status Register B3: CRCERR - CRC Checksum Error

In receive mode this bit will be updated at the end of a SFP, RHB, RILB or RSID task (when BFREE goes high) to reflect the result of the receive CRC check. '0' indicates that the CRC was received correctly, '1' indicates an error. In transmit mode this bit will be '0'.

Note that this bit should be ignored when an 'Intermediate' block (which does not have an integral CRC) is received.

The bit is cleared to '0' by a RESET task, or by changing the TX/RX, ZP or PSAVE bits of the Mode Register.

4.6.5.6 Status Register B2: SRDY - 'S' Symbol Ready

In receive mode this bit is set to '1' whenever an 'S' symbol or channel status bit (other than the 94th bit) has been received. In RD-LAP mode the μ C may then read the value of the symbol from the SVAL field of the Status Register. In MDC mode the value of the received channel status bit will be in bit 0 of the Status Register.

In transmit mode this bit is set to '1' whenever an 'S' symbol or channel status bit (other than the 94th bit) has been transmitted.

The bit is cleared to '0' immediately after a read of the Status Register, by a RESET task or by changing the TX/RX, ZP or PSAVE bits of the Mode Register.

4.6.5.7 Status Register B1, B0: RD-LAP Mode: SVAL - Received 'S' Symbol Value

In receive RD-LAP mode these two bits reflect the value of the latest received 'S' symbol. In transmit mode, these two bits will be '0'.

4.6.5.8 Status Register B1: MDC Mode: Received Frame Sync Type

In receive MDC mode this bit reflects the type of Frame Synchronization pattern received:

'0' indicates Frame Sync SYNC1 (\$07092A446F, MSB first)

'1' indicates Frame Sync SYNC2 (logical inverse of SYNC1)

4.6.5.9 Status Register B0: MDC Mode: SBIT - Received Channel Status Bit

In receive MDC mode this bit reflects the value of the latest received channel status bit. In transmit mode, this bit will be '0'.

4.6.6 Data Quality Register

In receive mode, the CMX969 continually measures the 'quality' of the received signal, by comparing the actual received waveform against an internally generated 'ideal' 2 or 4-level FSK baseband signal.

The result is placed into bits 3-7 of the Data Quality Register for the μ C to read at any time, bits 0-2 being always set to '0'. Figure 14 shows how the value (0-255) read from the Data Quality Register varies with received raw (uncorrected) bit error rate:

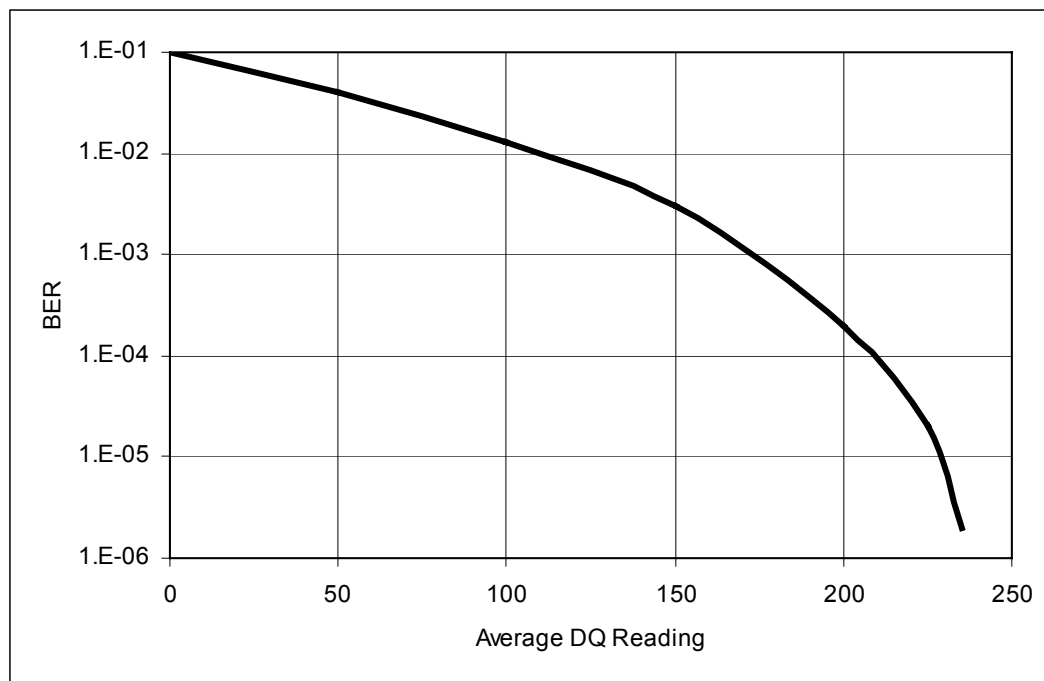

Figure 14: Typical Data Quality Reading vs. BER (uncorrected)

The Data Quality readings are only valid when the modem has successfully acquired signal level and timing lock for at least 64 symbol times. A low reading will be obtained if the received signal waveform is distorted in any significant way.

5 Application Notes

5.1 Autonomous Frame Sync Detect Function

In receive mode the CMX969 needs to know the received signal levels and symbol timing in order to successfully extract the received data from the incoming signal. This can be done by using the AFSD function to establish the levels and timing from the Frame Sync pattern at the start of a received message.

The AFSD function is enabled whenever bit 7 of the Command Register is 1 and operates in parallel with any other receive task that may be running. It monitors the received signal for the presence of a Frame Sync pattern without regard for any preconceived idea of the symbol timing or levels. When a Frame Sync pattern is found the AFSD function then uses it to establish the optimum timing and levels for extracting the following data.

This contrasts with the SFS and SFP (Search for Frame Sync and Search for Frame Preamble) tasks that rely on previously established timing and level information and - when a Frame Sync pattern is detected - do not change these timing and level settings.

On detecting a Frame Sync pattern, the AFSD function sets the AFSDDET and IRQ bits of the Status Register and terminates any other current task.

AFSD should be enabled to look for a Frame Sync pattern whenever the CMX969 is switched to receive mode or the radio is switched to a new receive channel or when the transmitter may have been switched off - in fact in any circumstance where the correct levels and timing need to be re-established.

Once Frame Sync has been detected, the AFSD function may be switched off if it is known that the transmitter is sending continuous concatenated frames, in which case SFS or SFP tasks should be used to find subsequent Frame Sync patterns. Alternatively, the AFSD function may be used instead of SFS to find all received Frame Sync patterns.

If the system is operating in SFR (Single Frequency Re-use) mode and so has to be able to detect the start of a new (stronger) transmission then AFSD should be left running so that it can detect the new transmitter and automatically abort any current task and adjust the timing and level settings to suit the new signal.

5.2 Rx Control Procedure

The following procedure illustrates how the CMX969 can be controlled to receive one or more messages in MDC mode. RD-LAP mode is similar except that the first block of each message will be a Station ID block.

Step	Action	Description
0	Switch radio onto receive channel. CMX969 Mode Register $\overline{\text{IRQEN}}$, INVSYM , and SSIEN bits should be set as required, other bits 0. Control Register should have CKDIV bits set as required, MDC bit = 1, all other bits 0.	
1	Write $\text{RESET} + \text{AFSD}$ (87h) to Command Register	Reset the device and start searching for a Frame Sync pattern using AFSD. AFSD should always be used instead of SFS to look for the first Frame Sync when switching into Rx mode or when the Rx channel is changed.
2	Wait for Status Register AFSDET bit to go to 1	AFSDET will go to 1 when Frame Sync is detected.
3	Write $\text{RHB} + \text{AFSD}$ (82h) to Command Register	Tell the CMX969 to receive and decode the first Header block. Keep AFSD function running in case a false Frame Sync had been detected or in case a new transmitter starts up on this radio channel.
4	Wait for Status Register AFSDET or BFREE bits to go to 1 If AFSDET bit = 1 then a new Frame Sync has been detected so go to step 3. If $\text{AFSDET} = 0$ and $\text{BFREE} = 1$, the previous Rx task (RHB and RILB) has completed. Read Rx data from Data Buffer. Check the Status Register CRCERR bit if it was a Header block or the 'last' Data block.	Wait for the CMX969 to finish the current task or for the AFSD function to recognize a new Frame Sync. If a new Frame Sync has been detected then it is the start of a new message so abandon the 'old' one and start to receive and decode the 'new' one. CMX969 has received and decoded a Header, Intermediate, or Last block. Read the data and check the CRC if the block contained one.
5	To receive and decode the next block from this Rx message write $\text{AFSD} + \text{RHB}$ or RILB (82h or 83h) to the Command Register and go to step 4	If we want to continue receiving the rest of this Rx message then tell the CMX969 to receive and decode the next block. Keep the AFSD function running in case a new transmitter starts up on this channel (SFR)
	If we have received all of the blocks in the message or wish to ignore any following blocks in this message then write AFSD (80h) to the Command Register and go to step 2.	AFSD will detect the next Frame Sync pattern. See Note.

Note: Once a Frame Sync pattern has been detected with AFSD then if the radio is receiving concatenated messages and if the system does not employ Single Frequency Reuse techniques subsequent Frame Sync patterns may be detected by using a SFS task (04h) instead of AFSD. Using SFS will reduce the very small chance of a false Frame Sync detection. Note that the SFS task signals that it has found a Frame Sync pattern by setting the Status Register BFREE bit to 1, whereas AFSD sets the AFSDET bit.

6 Performance Specification

6.1 Electrical Performance

6.1.1 Absolute Maximum Ratings

Exceeding these maximum ratings can result in damage to the device.

	Min.	Max.	Units
Supply ($V_{DD} - V_{SS}$)	-0.3	7.0	V
Voltage on any pin to V_{SS}	-0.3	$V_{DD} + 0.3$	V
Current into or out of V_{DD} and V_{SS} pins	-30	+30	mA
Current into or out of any other pin	-20	+20	mA
P4 Package			
Total Allowable Power Dissipation at $T_{AMB} = 25^{\circ}\text{C}$		800	mW
Derating above 25°C		13	mW/ $^{\circ}\text{C}$ above 25°C
Storage Temperature	-55	+125	$^{\circ}\text{C}$
Operating Temperature	-40	+85	$^{\circ}\text{C}$
E2 Package			
Total Allowable Power Dissipation at $T_{AMB} = 25^{\circ}\text{C}$		400	mW
Derating above 25°C		5.3	mW/ $^{\circ}\text{C}$ above 25°C
Storage Temperature	-55	+125	$^{\circ}\text{C}$
Operating Temperature	-40	+85	$^{\circ}\text{C}$
D5 Package			
Total Allowable Power Dissipation at $T_{AMB} = 25^{\circ}\text{C}$		550	mW
Derating above 25°C		9	mW/ $^{\circ}\text{C}$ above 25°C
Storage Temperature	-55	+125	$^{\circ}\text{C}$
Operating Temperature	-40	+85	$^{\circ}\text{C}$

6.1.2 Operating Limits

Correct operation of the device outside these limits is not implied.

Correct operation for supply voltages less than 3.0V are subject to a restricted temperature range.

	Notes	Min.	Max.	Units
Supply ($V_{DD} - V_{SS}$)		2.7	5.5	V
Operating Temperature		-40	+85	$^{\circ}\text{C}$
Symbol Rate		2000	9700	Symbols/sec
Xtal Frequency		1.0	10.0	MHz

6.1.3 Operating Characteristics

Details in this section represent design target values and are not currently guaranteed.

For the following conditions unless otherwise specified:

Xtal Frequency = 4.9152MHz.

Symbol Rate = RD-LAP mode 9600 symbols/sec, MDC mode 4800 symbols/sec.

V_{DD} = 3.0V to 5.5V, T_{AMB} = - 40°C to +85°C.

	Notes	Min.	Typ.	Max.	Units
DC Parameters					
I_{DD}					
$V_{DD} = 5.0V$	1		4.0	9.0	mA
$V_{DD} = 3.3V$	1		2.5	5.0	mA
Powersave Mode, $V_{DD} = 5.0V$	1		1.5		mA
Powersave Mode, $V_{DD} = 3.3V$	1		0.8		mA
Zero Power Mode, $V_{DD} = 5.0V$ (Mode Register TX/RX bit set to 0)	1			10.0	μA
AC Parameters					
Tx Output					
TXOUT Impedance	2		1.0	2.5	k Ω
Signal Level RD-LAP	3	1.6	2.0	2.4	V_{P-P}
Signal Level MDC	3	0.71	0.89	1.07	V_{P-P}
Output DC Offset with respect to $V_{DD}/2$	4	-0.25		+0.25	V
Rx Input					
RXIN Impedance (at 100Hz)			10.0		M Ω
RXIN Amp Voltage Gain (Input = 1mV _{RMS} at 100Hz)			300		V/V
Input Signal Level RD-LAP	5	1.0		2.5	V_{P-P}
Input Signal Level MDC	5	0.5		1.2	V_{P-P}
DC Offset with respect to $V_{DD}/2$	5	-1.0		+1.0	V
Xtal Input					
'High' Pulse Width	6	40.0			ns
'Low' Pulse Width	6	40.0			ns
Input Impedance (at 100Hz)		10.0			M Ω
Inverter Gain (Input = 1mV _{RMS} at 100Hz)		20.0			dB
μC Interface					
Input Logic "1" Level	7, 8	70%			V_{DD}
Input Logic "0" Level	7, 8			30%	V_{DD}
Input Leakage Current ($V_{IN} = 0$ to V_{DD})	7, 8	-5.0		+5.0	μA
Input Capacitance	7, 8		10.0		pF
Output Logic "1" Level ($I_{OH} = 120\mu A$)	8	92%			V_{DD}
Output Logic "0" Level ($I_{OL} = 360\mu A$)	8, 9			8%	V_{DD}
'Off' State Leakage Current ($V_{OUT} = V_{DD}$)	9			10.0	μA

Operating Characteristics Notes:

1. At 25°C. Not including any current drawn from the modem pins by external circuitry other than the Xtal oscillator.
2. Small signal impedance, at $V_{DD} = 5.0V$ and $T_{AMB} = 25^{\circ}C$.
3. For a "+3 +3 -3 -3..." symbol sequence in RD-LAP mode, "+1 -1 .." in MDC mode, at $V_{DD} = 5.0V$ and $T_{AMB} = 25^{\circ}C$ (Tx output level is proportional to V_{DD}).
4. Measured at the TXOUT pin with the modem in Rx or Tx idle mode.
5. For optimum performance, measured at RXFB pin, for a "...+3 +3 -3 -3..." symbol sequence in RD-LAP mode, "+1 -1 " in MDC mode, at $V_{DD} = 5.0V$ and $T_{AMB} = 25^{\circ}C$. The optimum input level and DC offset values are proportional to V_{DD} . Signal peaks should not go outside of the range ($V_{SS} + 0.25V$) to ($V_{DD} - 0.25V$).
6. Timing for an external input to the XTAL pin.
7. \overline{WR} , \overline{RD} , \overline{CS} , A0 and A1 pins.
8. D0 - D7 pins.
9. \overline{IRQ} pin.

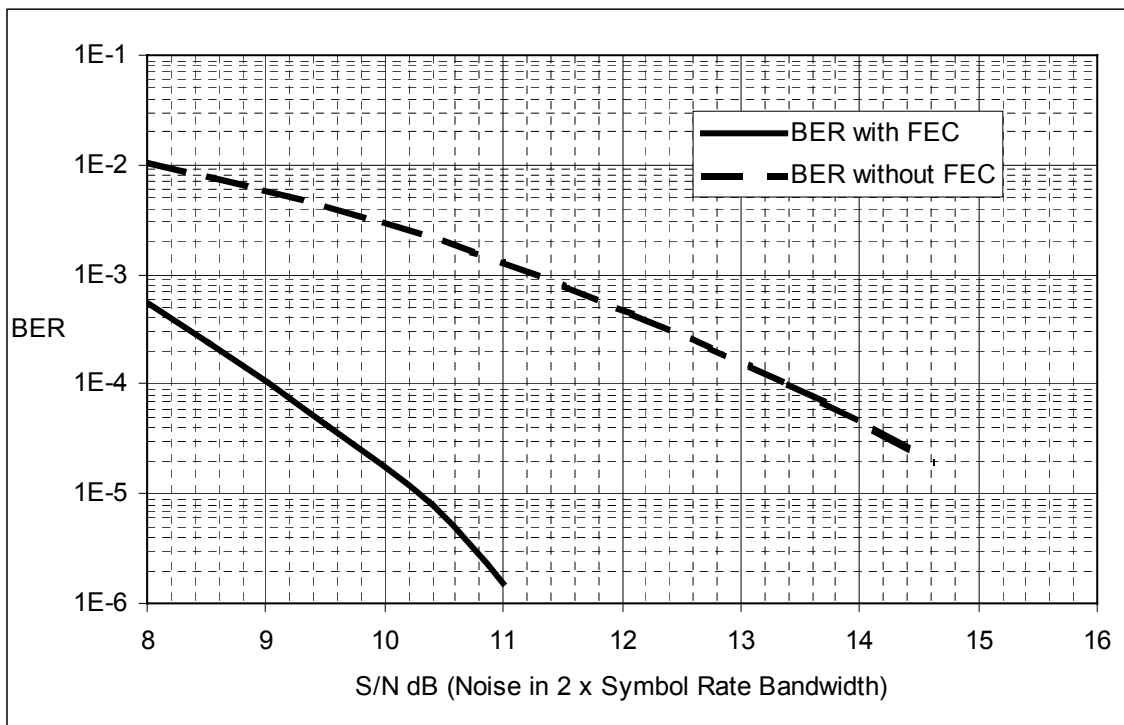

Figure 15: Typical Bit Error Rate With and Without FEC: RD-LAP Mode

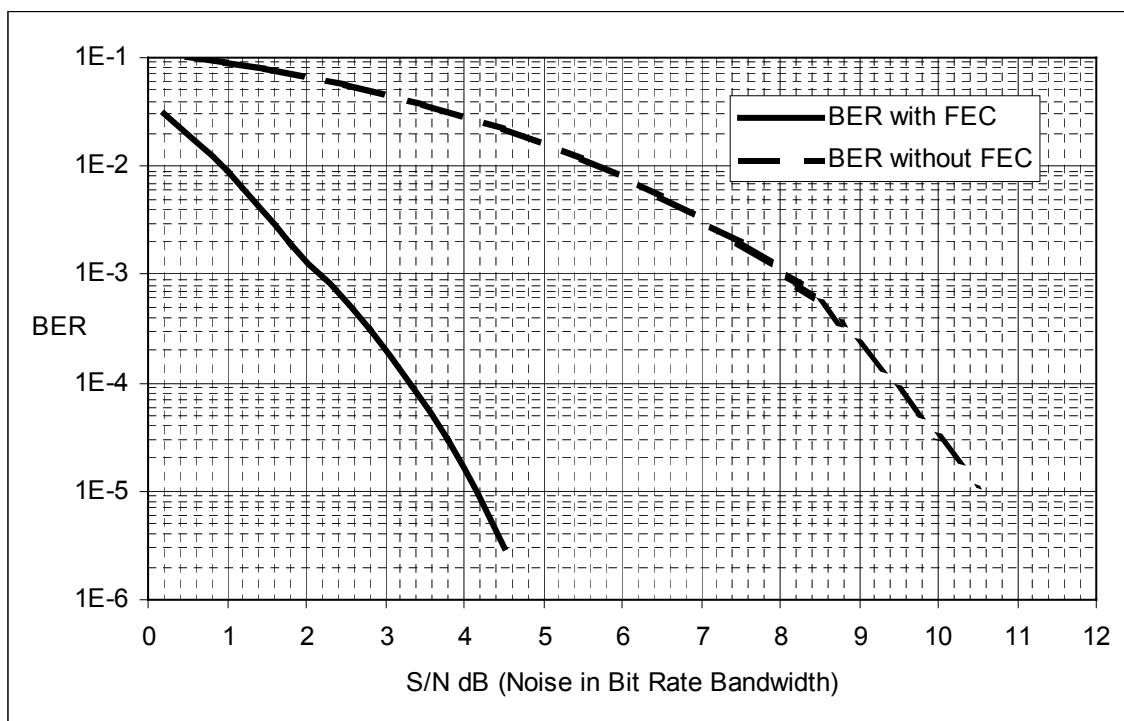

Figure 16: Typical Bit Error Rate With and Without FEC: MDC Mode

Note: BER vs. S/N measured under nominal working conditions, after a Frame Sync has been detected using AFSD, with pseudo-random data.

μ C Parallel Interface Timings (ref. Figure 17)		Notes	Min.	Typ.	Max.	Units
t_{ACSL}	Address valid to \overline{CS} low time		0			ns
t_{AH}	Address hold time		0			ns
t_{CSH}	\overline{CS} hold time		0			ns
t_{CSHI}	\overline{CS} high time	1	6.0			clock cycles
t_{CSRWL}	\overline{CS} to \overline{WR} or \overline{RD} low time		0			ns
t_{DHR}	Read data hold time		0			ns
t_{DHW}	Write data hold time		0			ns
t_{DSW}	Write data setup time		90.0			ns
t_{RHCSL}	\overline{RD} high to \overline{CS} low time (write)		0			ns
t_{RACL}	Read access time from \overline{CS} low	2			175	ns
t_{RARL}	Read access time from \overline{RD} low	2			145	ns
t_{RL}	\overline{RD} low time		200			ns
t_{RX}	\overline{RD} high to D0-D7 3-state time				50.0	ns
t_{WHCSL}	\overline{WR} high to \overline{CS} low time (read)		0			ns
t_{WL}	\overline{WR} low time		200			ns

Notes:

1. Xtal clock cycles at the XTAL pin.
2. With 30pF max to V_{SS} on D0 - D7 pins.

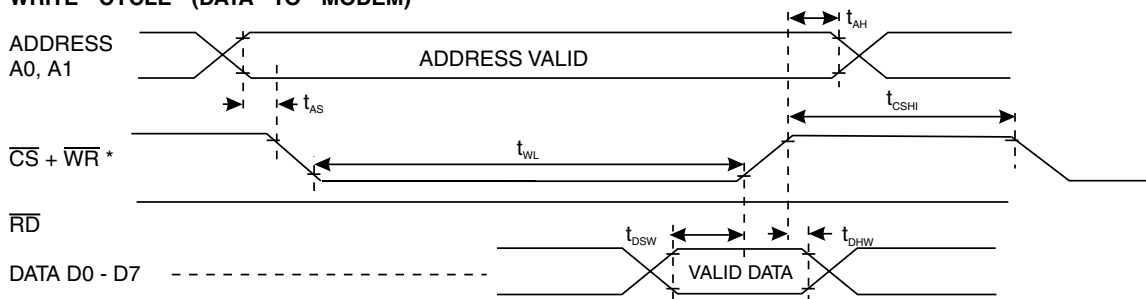
WRITE CYCLE (DATA TO MODEM)

* logical 'or' of \overline{CS} and \overline{WR} signals

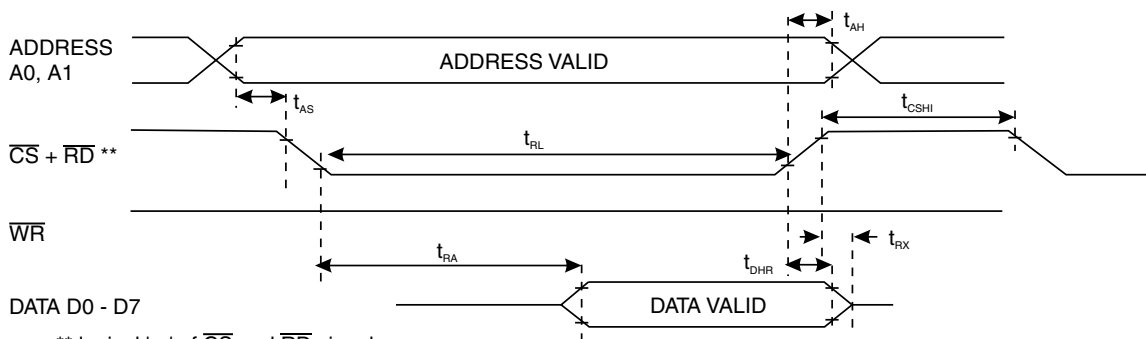
READ CYCLE (DATA FROM MODEM)

** logical 'or' of \overline{CS} and \overline{RD} signals

Figure 17: μ C Parallel Interface Timings

6.2 Packaging

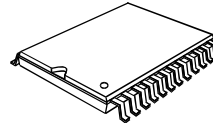
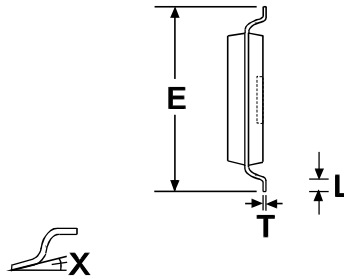
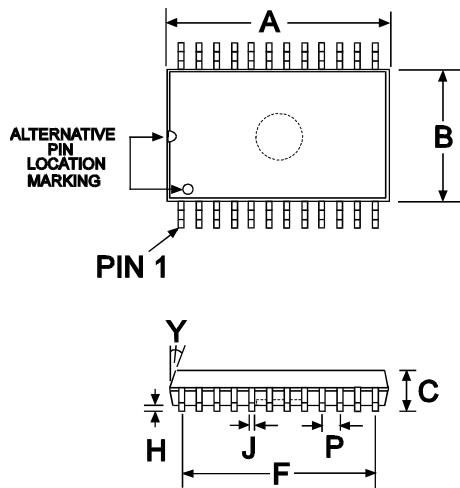

DIM.	MIN.	TYP.	MAX.
* A	0.303 (7.70)		0.311 (7.90)
* B	0.169 (4.30)		0.177 (4.50)
C	-----		0.047 (1.20)
E	0.248 (6.30)		0.256 (6.50)
F		0.286 (7.15)	
H	0.002 (0.05)		0.006 (0.15)
J	0.007 (0.17)		0.012 (0.30)
L	0.020 (0.50)		0.030 (0.75)
P		0.026 (0.65)	
T	0.003 (0.08)		0.008 (0.20)
X	0°		7°
Y		12°	

NOTE :

* A & B are reference datum's and do not include mold deflash or protrusions.

All dimensions in inches (mm.)
Angles are in degrees

Figure 18: 24-pin TSSOP (E2) Mechanical Outline: *Order as part no. CMX969E2*

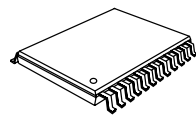
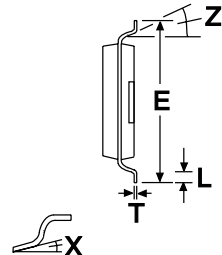
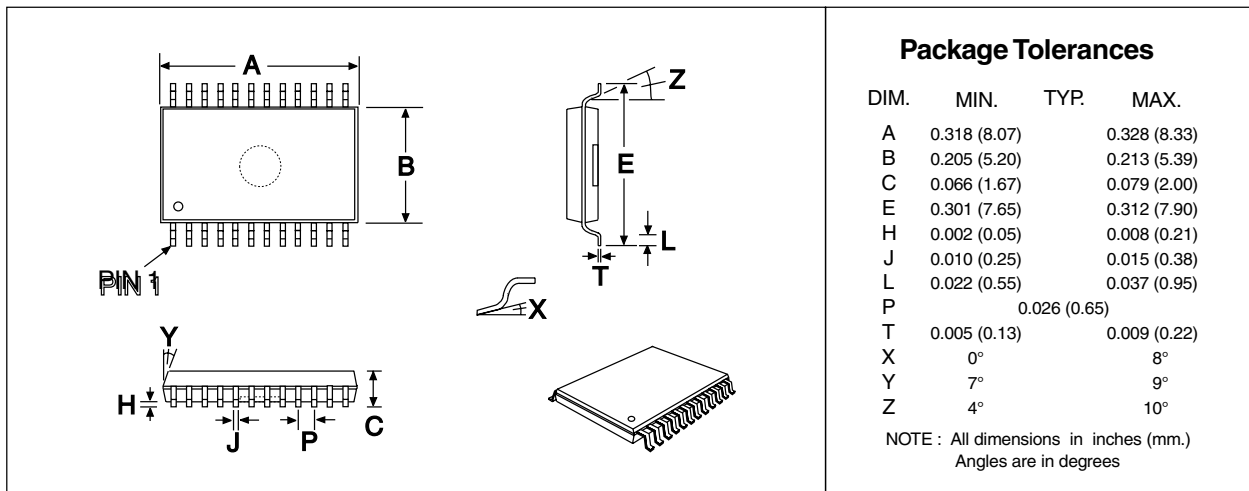

Package Tolerances

DIM.	MIN.	TYP.	MAX.
A	0.318 (8.07)		0.328 (8.33)
B	0.205 (5.20)		0.213 (5.39)
C	0.066 (1.67)		0.079 (2.00)
E	0.301 (7.65)		0.312 (7.90)
H	0.002 (0.05)		0.008 (0.21)
J	0.010 (0.25)		0.015 (0.38)
L	0.022 (0.55)		0.037 (0.95)
P		0.026 (0.65)	
T	0.005 (0.13)		0.009 (0.22)
X	0°		8°
Y	7°		9°
Z	4°		10°

NOTE : All dimensions in inches (mm.)
Angles are in degrees

Figure 19: 24-pin SSOP (D5) Mechanical Outline: *Order as part no. CMX969D5*

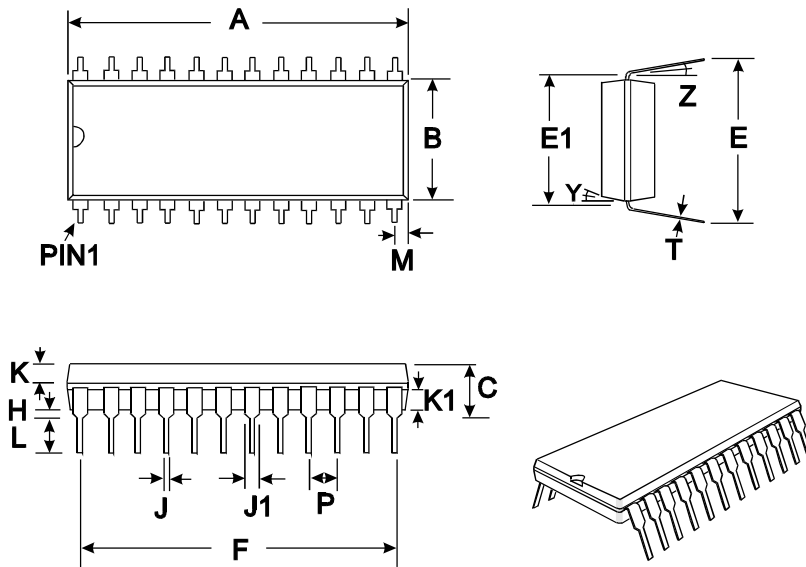

DIM.	MIN.	TYP.	MAX.
* A	1.200 (30.48)		1.270 (32.26)
* B	0.500 (12.70)		0.555 (14.10)
C	0.151 (3.84)		0.220 (5.59)
E	0.600 (15.24)		0.670 (17.02)
E1	0.590 (14.99)		0.625 (15.88)
F		1.10 (27.94)	
H	0.015 (0.38)		0.045 (1.14)
J	0.015 (0.38)		0.023 (0.58)
J1	0.040 (1.02)		0.065 (1.65)
K	0.066 (1.68)		0.074 (1.88)
K1	0.060 (1.52)		0.074 (1.88)
L	0.121 (3.07)		0.160 (4.06)
M		0.180 (4.58)	
P		0.100 (2.54)	
T	0.008 (0.20)		0.015 (0.38)
Y		7°	
Z		4°	

NOTE :

* A & B are reference datum's and do not include mold deflash or protrusions.

All dimensions in inches (mm.)
Angles are in degrees

Figure 20: 24-pin PDIP (P4) Mechanical Outline: *Order as part no. CMX969P4*