

NPN Darlington Power Silicon Transistor

Rev. V1

Features

- Available in JAN, JANTX, JANTXV per MIL-PRF-19500/518
- TO-66 (TO-213AA) Package



Electrical Characteristics

Parameter	Test Conditions	Symbol	Units	Min.	Max.
Off Characteristics					
Collector - Emitter Breakdown Voltage	$I_C = 100 \text{ mAdc}$, 2N6300 $I_C = 100 \text{ mAdc}$, 2N6301	$V_{(BR)CEO}$	Vdc	60 80	—
Collector - Emitter Cutoff Current	$V_{CE} = 30 \text{ Vdc}$, 2N6300 $V_{CE} = 40 \text{ Vdc}$, 2N6301	I_{CEO}	μAdc	—	500 500
Collector - Emitter Cutoff Current	$V_{CE} = 60 \text{ Vdc}$, $V_{BE} = 1.5 \text{ Vdc}$, 2N6300 $V_{CE} = 80 \text{ Vdc}$, $V_{BE} = 1.5 \text{ Vdc}$, 2N6301	I_{CEX}	μAdc	—	10 10
Emitter - Base Cutoff Current	$V_{EB} = 6 \text{ Vdc}$	I_{EBO}	μAdc	—	500
On Characteristics¹					
Forward Current Transfer Ratio	$I_C = 1 \text{ Adc}$, $V_{CE} = 3 \text{ Vdc}$ $I_C = 4 \text{ Adc}$, $V_{CE} = 3 \text{ Vdc}$ $I_C = 8 \text{ Adc}$, $V_{CE} = 3 \text{ Vdc}$	H_{FE}	-	500 700 100	18,000
Collector - Emitter Saturation Voltage	$I_C = 4 \text{ Adc}$, $I_B = 16 \text{ Adc}$ $I_C = 8 \text{ Adc}$, $I_B = 80 \text{ Adc}$	$V_{CE(SAT)}$	Vdc	—	2.0 3.0
Base - Emitter Saturation Voltage	$I_C = 8 \text{ Adc}$, $I_B = 80 \text{ Adc}$	$V_{CE(SAT)}$	Vdc	—	4.0
Base - Emitter Voltage	$I_C = 1 \text{ Adc}$, $V_{CE} = 10 \text{ Vdc}$	$V_{BE(ON)}$	Vdc	—	2.8
Dynamic Characteristics					
Magnitude of Common Emitter Small-Signal Short-Circuit Forward Current Transfer Ratio	$I_C = 3 \text{ Adc}$, $V_{CE} = 3 \text{ Vdc}$, $f = 1.0 \text{ kHz}$	$ H_{FE} $	-	25	350
Small-Signal Short-Circuit Forward Current Transfer Ratio	$I_C = 3 \text{ Adc}$, $V_{CE} = 3 \text{ Vdc}$, $f = 1.0 \text{ kHz}$	$ H_{FE} $	-	300	—
Output Capacitance	$V_{CB} = 10 \text{ Vdc}$, $I_E = 0$, $100 \text{ kHz} \leq f \leq 1 \text{ MHz}$	C_{OBO}	pF	—	200
Switching Characteristics					
Turn-On Time	$V_{CC} = 30 \text{ Vdc}$; $I_C = 4.0 \text{ Adc}$; $I_{B1} = 16 \text{ mAdc}$	T_{ON}	μs	—	2.0
Turn-Off Time	$V_{CC} = 30 \text{ Vdc}$; $I_C = 4.0 \text{ Adc}$; $I_{B1} = 16 \text{ mAdc}$	T_{OFF}	μs	—	8.0
Safe Operating Area					
DC Tests:	$T_C = +25 \text{ }^\circ\text{C}$, 1 Cycle, $t = 1.0 \text{ s}$				
Test 1:	$V_{CE} = 8.0 \text{ Vdc}$, $I_C = 8.0 \text{ Adc}$				
Test 2:	$V_{CE} = 20 \text{ Vdc}$, $I_C = 2.0 \text{ Adc}$				
Test 3:	$V_{CE} = 60 \text{ Vdc}$, $I_C = 100 \text{ Adc}$, 2N6300				
	$V_{CE} = 80 \text{ Vdc}$, $I_C = 100 \text{ Adc}$, 2N6301				

1. Pulse Test: Pulse Width = 300 μs , Duty Cycle $\leq 2.0\%$.

Absolute Maximum Ratings

Ratings	Symbol	Value
Collector - Emitter Voltage 2N6300 2N6301	V_{CEO}	60 Vdc 80 Vdc
Collector - Base Voltage 2N6300 2N6301	V_{CBO}	60 Vdc 80 Vdc
Emitter - Base Voltage	V_{EBO}	5 Vdc
Base Current	I_B	120 mAdc
Collector Current	I_C	8 Adc
Total Power Dissipation @ $T_C = 0^\circ\text{C}$ @ $T_C = 100^\circ\text{C}$	P_T	75 W 37 W
Operating & Storage Temperature Range	T_{OP}, T_{STG}	-55°C to $+200^\circ\text{C}$

1. Derate linearly @ 143 mW / °C between $T_C = 25^\circ\text{C}$ and $T_C = 200^\circ\text{C}$

Thermal Characteristics

Characteristics	Symbol	Max. Value
Thermal Resistance, Junction to Case	$R_{\theta JC}$	2.66°C/W

Outline Drawing

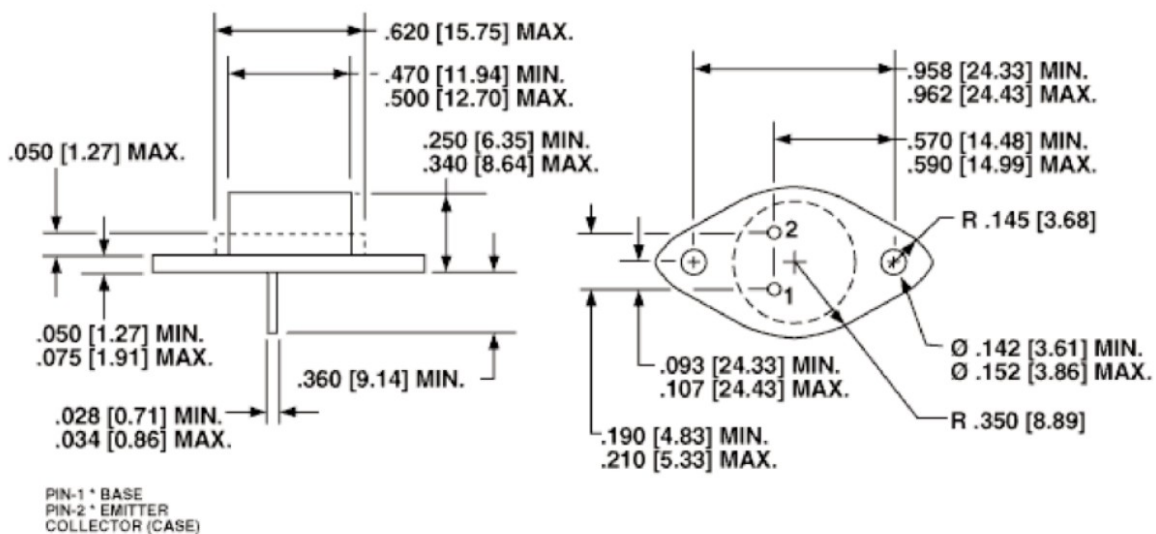

NOTE: Dimensions in Inches [mm]

MACOM Technology Solutions Inc. All rights reserved.

Information in this document is provided in connection with MACOM Technology Solutions Inc ("MACOM") products. These materials are provided by MACOM as a service to its customers and may be used for informational purposes only. Except as provided in MACOM's Terms and Conditions of Sale for such products or in any separate agreement related to this document, MACOM assumes no liability whatsoever. MACOM assumes no responsibility for errors or omissions in these materials. MACOM may make changes to specifications and product descriptions at any time, without notice. MACOM makes no commitment to update the information and shall have no responsibility whatsoever for conflicts or incompatibilities arising from future changes to its specifications and product descriptions. No license, express or implied, by estoppel or otherwise, to any intellectual property rights is granted by this document.

THESE MATERIALS ARE PROVIDED "AS IS" WITHOUT WARRANTY OF ANY KIND, EITHER EXPRESS OR IMPLIED, RELATING TO SALE AND/OR USE OF MACOM PRODUCTS INCLUDING LIABILITY OR WARRANTIES RELATING TO FITNESS FOR A PARTICULAR PURPOSE, CONSEQUENTIAL OR INCIDENTAL DAMAGES, MERCHANTABILITY, OR INFRINGEMENT OF ANY PATENT, COPYRIGHT OR OTHER INTELLECTUAL PROPERTY RIGHT. MACOM FURTHER DOES NOT WARRANT THE ACCURACY OR COMPLETENESS OF THE INFORMATION, TEXT, GRAPHICS OR OTHER ITEMS CONTAINED WITHIN THESE MATERIALS. MACOM SHALL NOT BE LIABLE FOR ANY SPECIAL, INDIRECT, INCIDENTAL, OR CONSEQUENTIAL DAMAGES, INCLUDING WITHOUT LIMITATION, LOST REVENUES OR LOST PROFITS, WHICH MAY RESULT FROM THE USE OF THESE MATERIALS.

MACOM products are not intended for use in medical, lifesaving or life sustaining applications. MACOM customers using or selling MACOM products for use in such applications do so at their own risk and agree to fully indemnify MACOM for any damages resulting from such improper use or sale.