

Description

Description

The M16C/30L group of single-chip microcomputers are built using the high-performance silicon gate CMOS process using a M16C/60 Series CPU core and are packaged in a 100-pin plastic molded QFP. These single-chip microcomputers operate using sophisticated instructions featuring a high level of instruction efficiency. With 1M bytes of address space, low voltage (2.2V to 3.6V), they are capable of executing instructions at high speed. They also feature a built-in multiplier and DMAC, making them ideal for controlling office, communications, industrial equipment, and other high-speed processing applications. The M16C/30L group includes a wide range of products with different internal memory sizes and various package types.

Features

- Memory capacity ROM (See Figure 1.1.4. ROM Expansion)
 RAM 2K to 3K bytes
- Shortest instruction execution time 62.5ns (f(XIN)=16MHz, VCC=3.0V to 3.6V)
 142.9ns (f(XIN)=7MHz, VCC=2.4V to 3.6V without software wait)
- Supply voltage 3.0V to 3.6V (f(XIN)=16MHz, without software wait)
 2.4V to 3.6V (f(XIN)=7MHz, without software wait)
 2.2V to 3.6V (f(XIN)=7MHz, with software one-wait)
- Low power consumption 34.0mW (VCC = 3V, f(XIN)=10MHz, without software wait)
 66.0mW (VCC = 3.3V, f(XIN)=16MHz, without software wait)
- Interrupts 16 internal and 5 external interrupt sources, 4 software
 interrupt sources; 7 levels (including key input interrupt)
- Multifunction 16-bit timer 3 output timers + 2 input timers
- Serial I/O 3 channels (3 for UART or clock synchronous)
- DMAC 1 channels (trigger: 14 sources)
- A-D converter 10 bits X 8 channels (Expandable up to 10 channels)
- Watchdog timer 1 line
- Programmable I/O port 87 lines
- Input port 1 line (P85 shared with $\overline{\text{NMI}}$ pin)
- Memory expansion Available (to a maximum of 1M bytes)
- Chip select output 4 lines
- Clock generating circuit 2 built-in clock generation circuits
 (built-in feedback resistor, and external ceramic or quartz oscillator)

Applications

Audio, cameras, office equipment, communications equipment, portable equipment

-----Table of Contents-----

Central Processing Unit (CPU)	11	Timer	75
Reset	14	Serial I/O	93
Processor Mode	21	A-D Converter	130
Clock Generating Circuit	34	Programmable I/O Ports	136
Protection	43	Electrical characteristics	146
Interrupt	44		
Watchdog Timer	64		
DMAC	66		

Pin Configuration

Figures 1.1.1 and 1.1.2 show the pin configurations (top view).

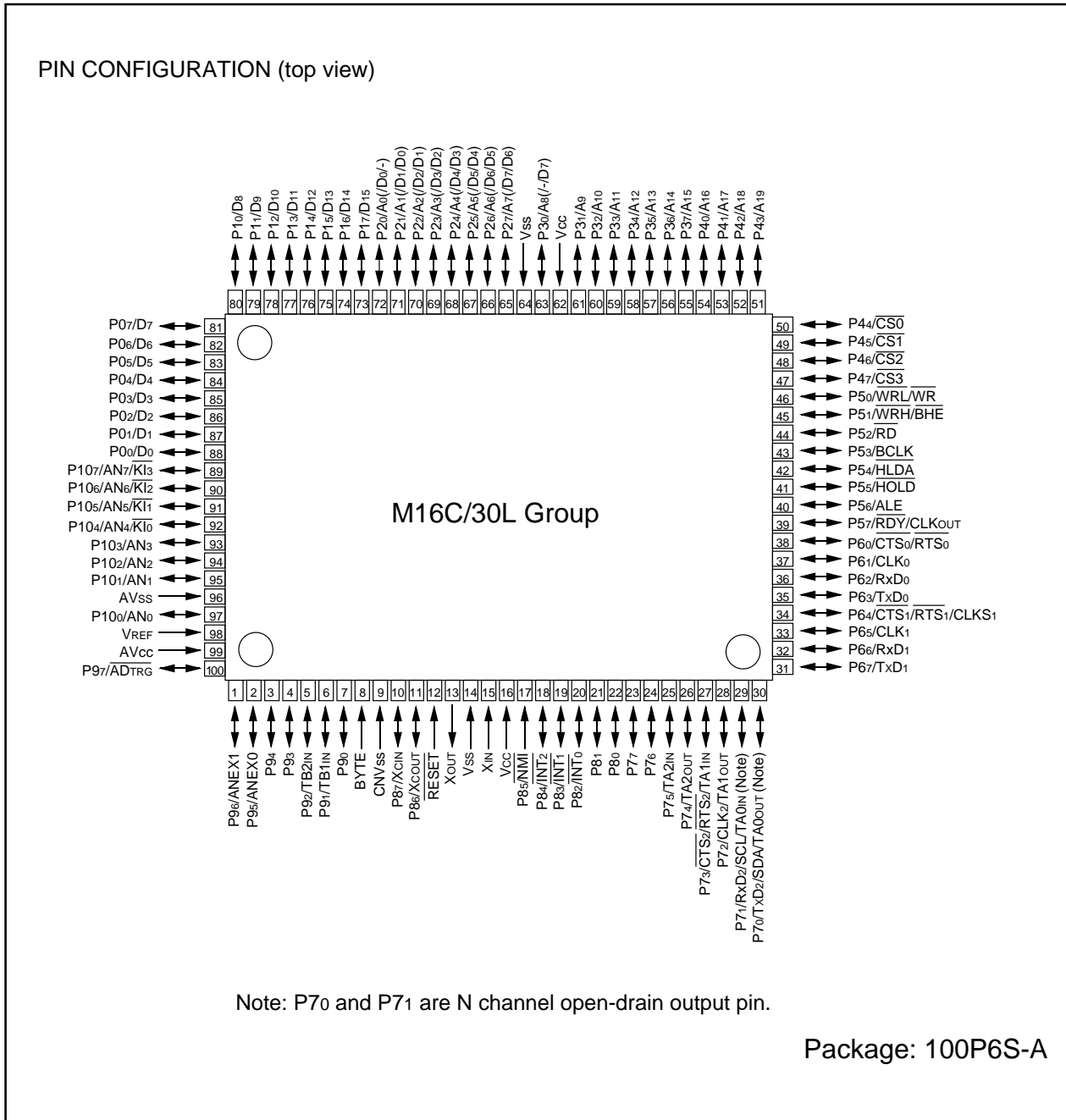

Figure 1.1.1. Pin configuration (top view)

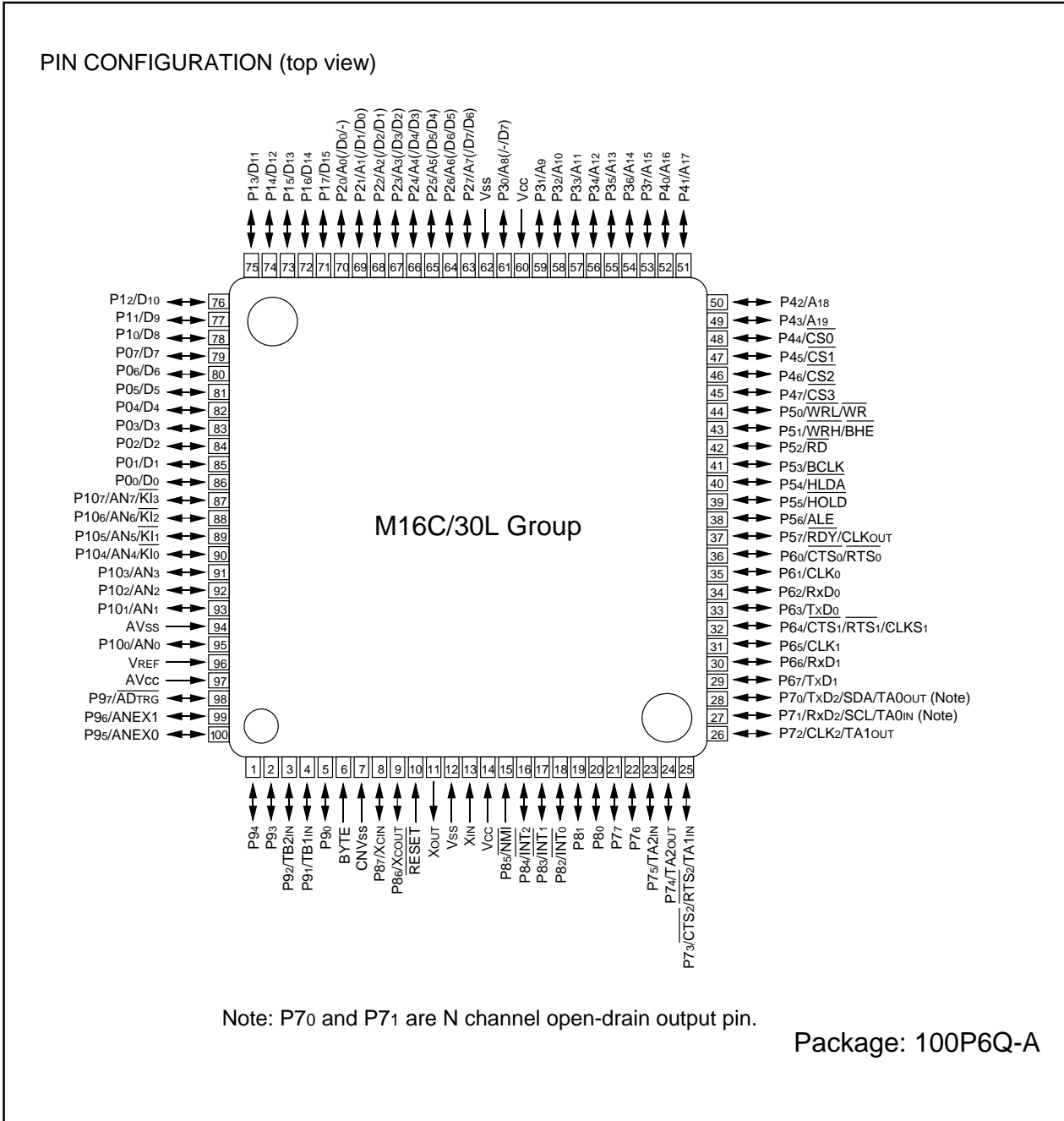

Figure 1.1.2. Pin configuration (top view)

Description

Block Diagram

Figure 1.1.3 is a block diagram of the M16C/30L group.

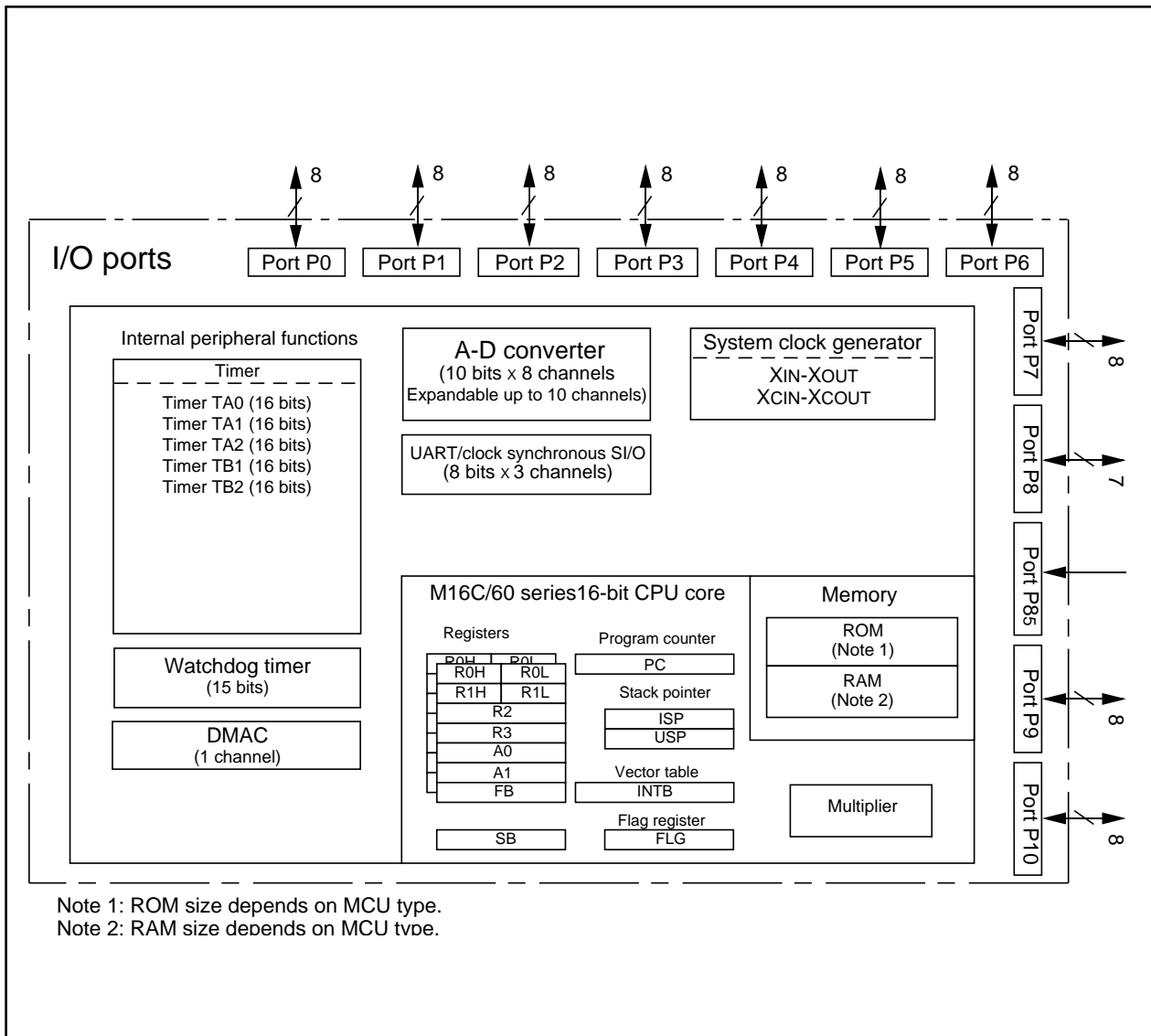

Figure 1.1.3. Block diagram of M16C/30L group

Performance Outline

Table 1.1.1 is a performance outline of M16C/30L group.

Table 1.1.1. Performance outline of M16C/30L group

Item		Performance
Number of basic instructions		91 instructions
Shortest instruction execution time		62.5ns($f(X_{IN})=16\text{MHz}$, $V_{CC}=3.0\text{V}$ to 3.6V) 142.9ns($f(X_{IN})=7\text{MHz}$, $V_{CC}=2.4\text{V}$ to 3.6V , without software wait)
Memory capacity	ROM	(See the figure 1.1.4. ROM Expansion)
	RAM	2K to 3K bytes
I/O port	P0 to P10 (except P85)	8 bits x 10, 7 bits x 1
Input port	P85	1 bit x 1
Multifunction timer	TA0, TA1, TA2	16 bits x 3
	TB1, TB2	16 bits x 2
Serial I/O	UART0, UART1, UART2	(UART or clock synchronous) x 3
A-D converter		10 bits x (8+2) channels
DMAC		1 channels (trigger: 14 sources)
Watchdog timer		15 bits x 1 (with prescaler)
Interrupt		16 internal and 5 external sources, 4 software sources, 7 levels
Clock generating circuit		2 built-in clock generation circuits (built-in feedback resistor, and external ceramic or quartz oscillator)
Supply voltage		3.0V to 3.6V ($f(X_{IN})=16\text{MHz}$, without software wait) 2.4V to 3.6V ($f(X_{IN})=7\text{MHz}$, without software wait) 2.2V to 3.6V ($f(X_{IN})=7\text{MHz}$, with software one-wait)
Power consumption		34.0mW ($V_{CC}=3\text{V}$, $f(X_{IN})=10\text{MHz}$, without software wait) 66.0mW ($V_{CC}=3.3\text{V}$, $f(X_{IN})=16\text{MHz}$, without software wait)
I/O characteristics	I/O withstand voltage	3.3V
	Output current	1mA
Memory expansion		Available (to a maximum of 1M bytes)
Device configuration		CMOS high performance silicon gate
Package		100-pin plastic mold QFP

Description

Mitsubishi plans to release the following products in the M16C/30L group:

- (1) Support for mask ROM version
- (2) ROM capacity
- (3) Package
 - 100P6S-A : Plastic molded QFP
 - 100P6Q-A : Plastic molded QFP

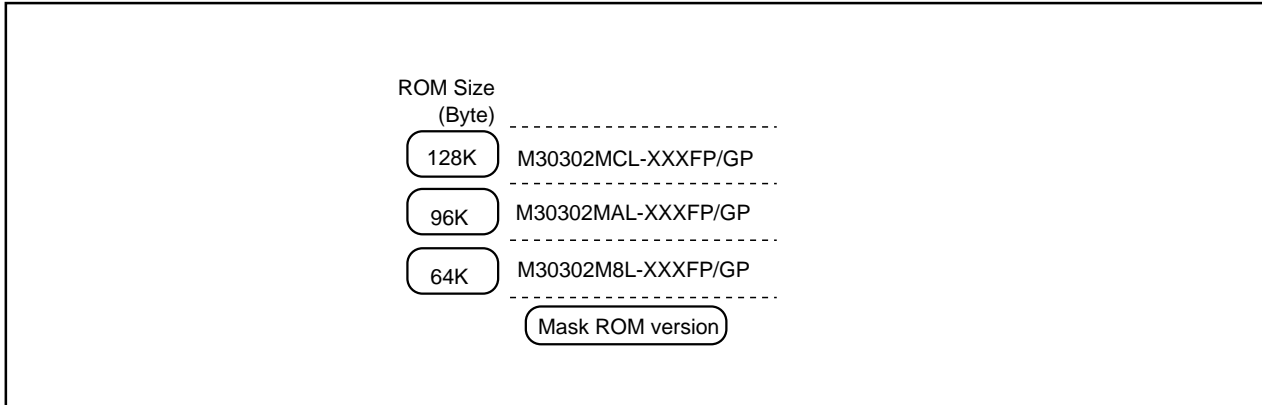

Figure 1.1.4. ROM expansion

The M16C/30L group products currently supported are listed in Table 1.1.2.

Table 1.1.2. M16C/30L group

June, 2002

Type No.	ROM capacity	RAM capacity	Package type	Remarks
M30302M8L-XXXFP **	64K byte	2K byte	100P6S-A	Mask ROM version
M30302M8L-XXXGP **			100P6Q-A	
M30302MAL-XXXFP **	96K byte	3K byte	100P6S-A	
M30302MAL-XXXGP **			100P6Q-A	
M30302MCL-XXXFP *	128K byte		100P6S-A	
M30302MCL-XXXGP *			100P6Q-A	

** : Under development

* : New product

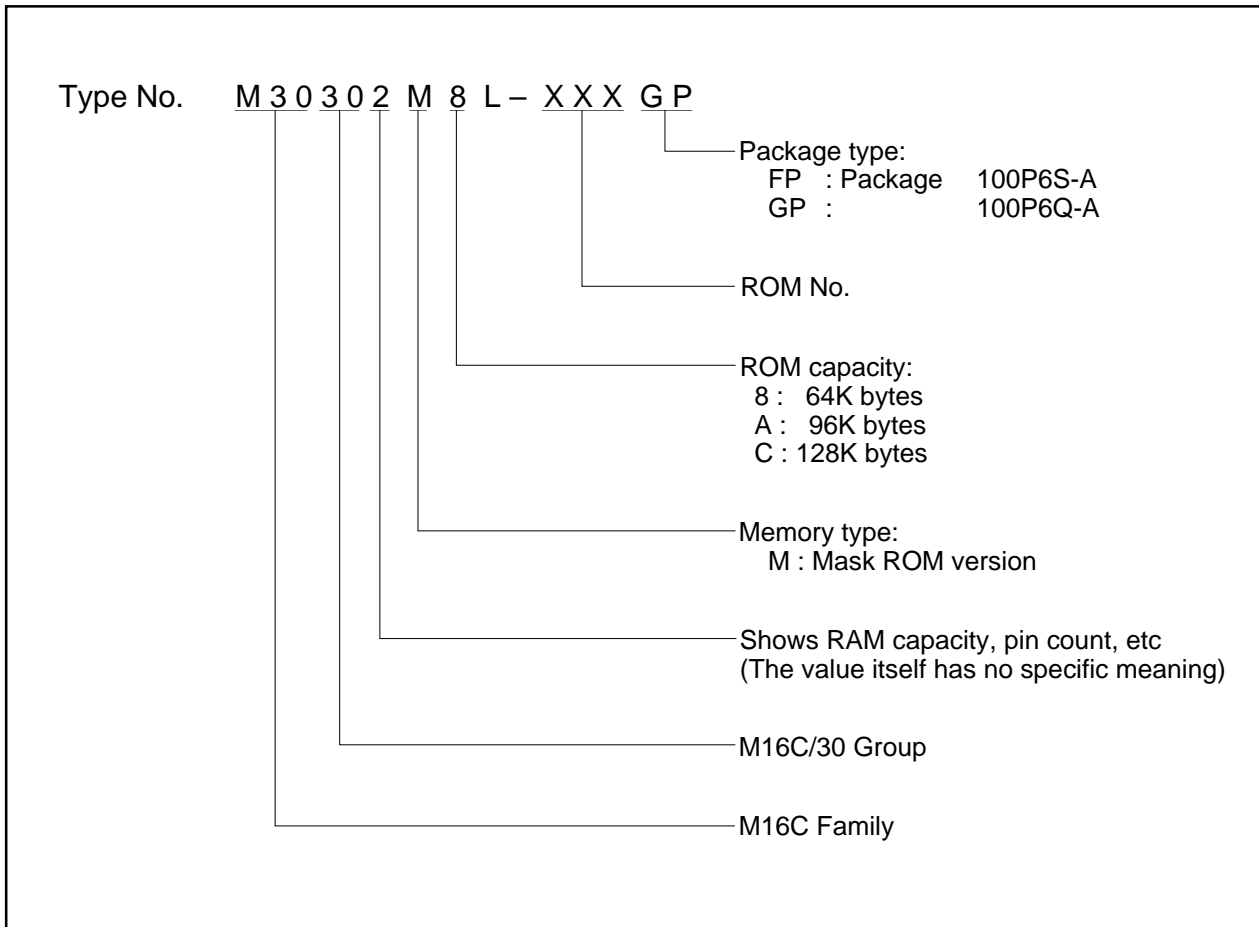

Figure 1.1.5. Type No., memory size, and package

Pin Description

Pin Description

Pin name	Signal name	I/O type	Function
VCC, VSS	Power supply input		Supply 2.2V to 3.6 V to the VCC pin. Supply 0 V to the VSS pin.
CNVSS	CNVSS	Input	This pin switches between processor modes. Connect this pin to the VSS pin when after a reset you want to start operation in single-chip mode (memory expansion mode) or the VCC pin when starting operation in microprocessor mode.
$\overline{\text{RESET}}$	Reset input	Input	A "L" on this input resets the microcomputer.
XIN	Clock input	Input	These pins are provided for the main clock generating circuit. Connect a ceramic resonator or crystal between the XIN and the XOUT pins. To use an externally derived clock, input it to the XIN pin and leave the XOUT pin open.
XOUT	Clock output	Output	
BYTE	External data bus width select input	Input	This pin selects the width of an external data bus. A 16-bit width is selected when this input is "L"; an 8-bit width is selected when this input is "H". This input must be fixed to either "H" or "L". Connect this pin to the VSS pin when not using external data bus.
AVCC	Analog power supply input		This pin is a power supply input for the A-D converter. Connect this pin to VCC.
AVSS	Analog power supply input		This pin is a power supply input for the A-D converter. Connect this pin to VSS.
VREF	Reference voltage input	Input	This pin is a reference voltage input for the A-D converter.
P00 to P07	I/O port P0	Input/output	This is an 8-bit CMOS I/O port. It has an input/output port direction register that allows the user to set each pin for input or output individually. When used for input in single-chip mode, the port can be set to have or not have a pull-up resistor in units of four bits by software. In memory expansion and microprocessor modes, selection of the internal pull-resistor is not available.
D0 to D7		Input/output	
P10 to P17	I/O port P1	Input/output	This is an 8-bit I/O port equivalent to P0.
D8 to D15		Input/output	When set as a separate bus, these pins input and output data (D8–D15).
P20 to P27	I/O port P2	Input/output	This is an 8-bit I/O port equivalent to P0.
A0 to A7		Output	These pins output 8 low-order address bits (A0–A7).
A0/D0 to A7/D7		Input/output	If the external bus is set as an 8-bit wide multiplexed bus, these pins input and output data (D0–D7) and output 8 low-order address bits (A0–A7) separated in time by multiplexing.
A0 A1/D0 to A7/D6		Output Input/output	If the external bus is set as a 16-bit wide multiplexed bus, these pins input and output data (D0–D6) and output address (A1–A7) separated in time by multiplexing. They also output address (A0).
P30 to P37	I/O port P3	Input/output	This is an 8-bit I/O port equivalent to P0.
A8 to A15		Output	These pins output 8 middle-order address bits (A8–A15).
A8/D7, A9 to A15		Input/output Output	If the external bus is set as a 16-bit wide multiplexed bus, these pins input and output data (D7) and output address (A8) separated in time by multiplexing. They also output address (A9–A15).
P40 to P47	I/O port P4	Input/output	This is an 8-bit I/O port equivalent to P0.
A16 to A19, CS0 to CS3		Output Output	These pins output A16–A19 and $\overline{\text{CS}}_0$ – $\overline{\text{CS}}_3$ signals. A16–A19 are 4 high-order address bits. CS0–CS3 are chip select signals used to specify an access space.

Pin Description

Pin Description

Pin name	Signal name	I/O type	Function
P50 to P57	I/O port P5	Input/output	This is an 8-bit I/O port equivalent to P0. In single-chip mode, P57 in this port outputs a divide-by-8 or divide-by-32 clock of XIN or a clock of the same frequency as XCIN as selected by software.
\overline{WRL} / \overline{WR} , \overline{WRH} / BHE, RD, BCLK, HLDA, HOLD, ALE, RDY		Output Output Output Output Input Output Input	Output \overline{WRL} , \overline{WRH} (\overline{WR} and BHE), RD, BCLK, HLDA, and ALE signals. \overline{WRL} and \overline{WRH} , and BHE and \overline{WR} can be switched using software control. <ul style="list-style-type: none"> ■ \overline{WRL}, \overline{WRH}, and \overline{RD} selected With a 16-bit external data bus, data is written to even addresses when the \overline{WRL} signal is "L" and to the odd addresses when the \overline{WRH} signal is "L". Data is read when RD is "L". ■ \overline{WR}, BHE, and RD selected Data is written when \overline{WR} is "L". Data is read when \overline{RD} is "L". Odd addresses are accessed when BHE is "L". Use this mode when using an 8-bit external data bus. While the input level at the HOLD pin is "L", the microcomputer is placed in the hold state. While in the hold state, HLDA outputs a "L" level. ALE is used to latch the address. While the input level of the RDY pin is "L", the microcomputer is in the ready state.
P60 to P67	I/O port P6	Input/output	This is an 8-bit I/O port equivalent to P0. When used for input in single-chip, memory expansion, and microprocessor modes, the port can be set to have or not have a pull-up resistor in units of four bits by software. Pins in this port also function as UART0 and UART1 I/O pins as selected by software.
P70 to P77	I/O port P7	Input/output	This is an 8-bit I/O port equivalent to P6 (P70 and P71 are N channel open-drain output). Pins in this port also function as timer A0–A2, or UART2 I/O pins as selected by software.
P80 to P84, P86, P87, P85	I/O port P8 I/O port P85	Input/output Input/output Input/output Input	P80 to P84, P86, and P87 are I/O ports with the same functions as P6. Using software, they can be made to function as the I/O pins for the input pins for external interrupts. P86 and P87 can be set using software to function as the I/O pins for a sub clock generation circuit. In this case, connect a quartz oscillator between P86 (XCOUT pin) and P87 (XCIN pin). P85 is an input-only port that also functions for NMI. The NMI interrupt is generated when the input at this pin changes from "H" to "L". The NMI function cannot be cancelled using software. The pull-up cannot be set for this pin.
P90 to P97	I/O port P9	Input/output	This is an 8-bit I/O port equivalent to P6. Pins in this port also function as, timer B1, B2 input pins, A-D converter extended input pins, or A-D trigger input pins as selected by software.
P100 to P107	I/O port P10	Input/output	This is an 8-bit I/O port equivalent to P6. Pins in this port also function as A-D converter input pins as selected by software. Furthermore, P104–P107 also function as input pins for the key input interrupt function.

Operation of Functional Blocks

The M16C/30L group accommodates certain units in a single chip. These units include ROM and RAM to store instructions and data and the central processing unit (CPU) to execute arithmetic/logic operations. Also included are peripheral units such as timers, serial I/O, DMAC, A-D converter, and I/O ports.

The following explains each unit.

Memory

Figure 1.3.1 is a memory map of the M16C/30L group. The address space extends the 1M bytes from address 00000₁₆ to FFFFF₁₆. From FFFFF₁₆ down is ROM. For example, in the M30302MCL-XXXGP, there is 128K bytes of internal ROM from E0000₁₆ to FFFFF₁₆. The vector table for fixed interrupts such as the reset and $\overline{\text{NMI}}$ are mapped to FFFDC₁₆ to FFFFF₁₆. The starting address of the interrupt routine is stored here. The address of the vector table for timer interrupts, etc., can be set as desired using the internal register (INTB). See the section on interrupts for details.

From 00400₁₆ up is RAM. For example, in the M30302MCL-XXXGP, 3K bytes of internal RAM is mapped to the space from 00400₁₆ to 00FFF₁₆. In addition to storing data, the RAM also stores the stack used when calling subroutines and when interrupts are generated.

The SFR area is mapped to 00000₁₆ to 003FF₁₆. This area accommodates the control registers for peripheral devices such as I/O ports, A-D converter, serial I/O, and timers, etc. Figures 1.6.1 to 1.6.3 are location of peripheral unit control registers. Any part of the SFR area that is not occupied is reserved and cannot be used for other purposes.

The special page vector table is mapped to FFE00₁₆ to FFFDB₁₆. If the starting addresses of subroutines or the destination addresses of jumps are stored here, subroutine call instructions and jump instructions can be used as 2-byte instructions, reducing the number of program steps.

In memory expansion mode and microprocessor mode, a part of the spaces are reserved and cannot be used. For example, in the M30302MCL-XXXGP, the following spaces cannot be used.

- The space between 01800₁₆ and 03FFF₁₆ (Memory expansion and microprocessor modes)
- The space between D0000₁₆ and DFFFF₁₆ (Memory expansion mode)

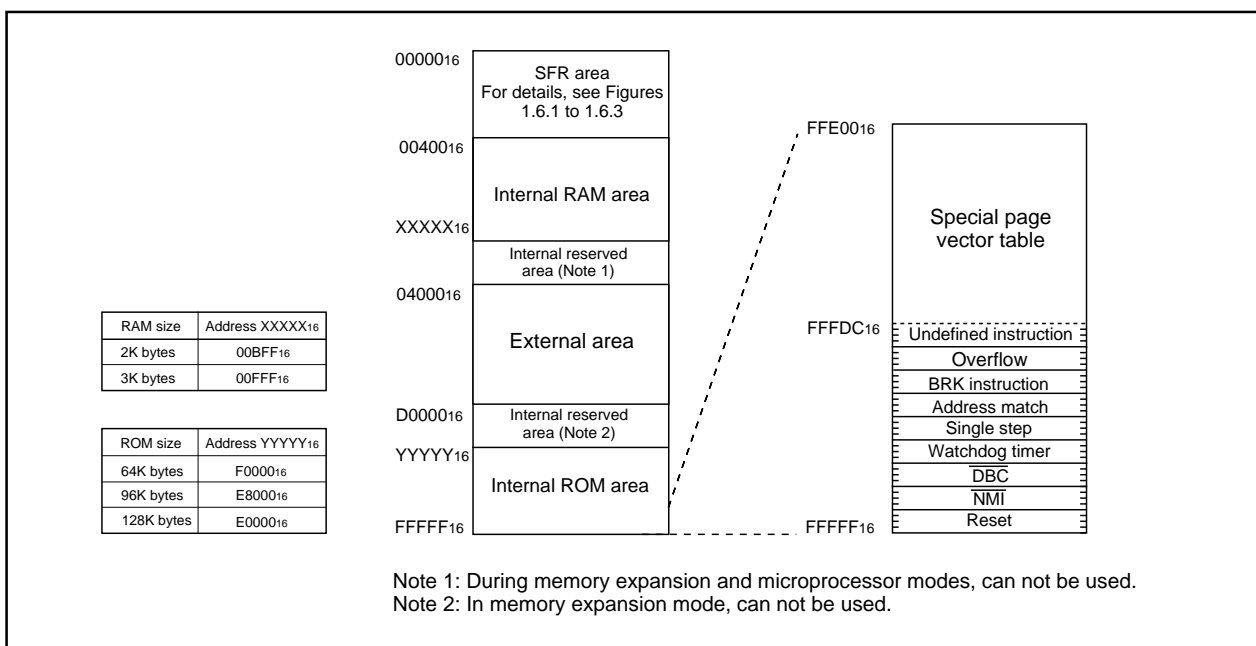

Figure 1.3.1. Memory map

Central Processing Unit (CPU)

The CPU has a total of 13 registers shown in Figure 1.4.1. Seven of these registers (R0, R1, R2, R3, A0, A1, and FB) come in two sets; therefore, these have two register banks.

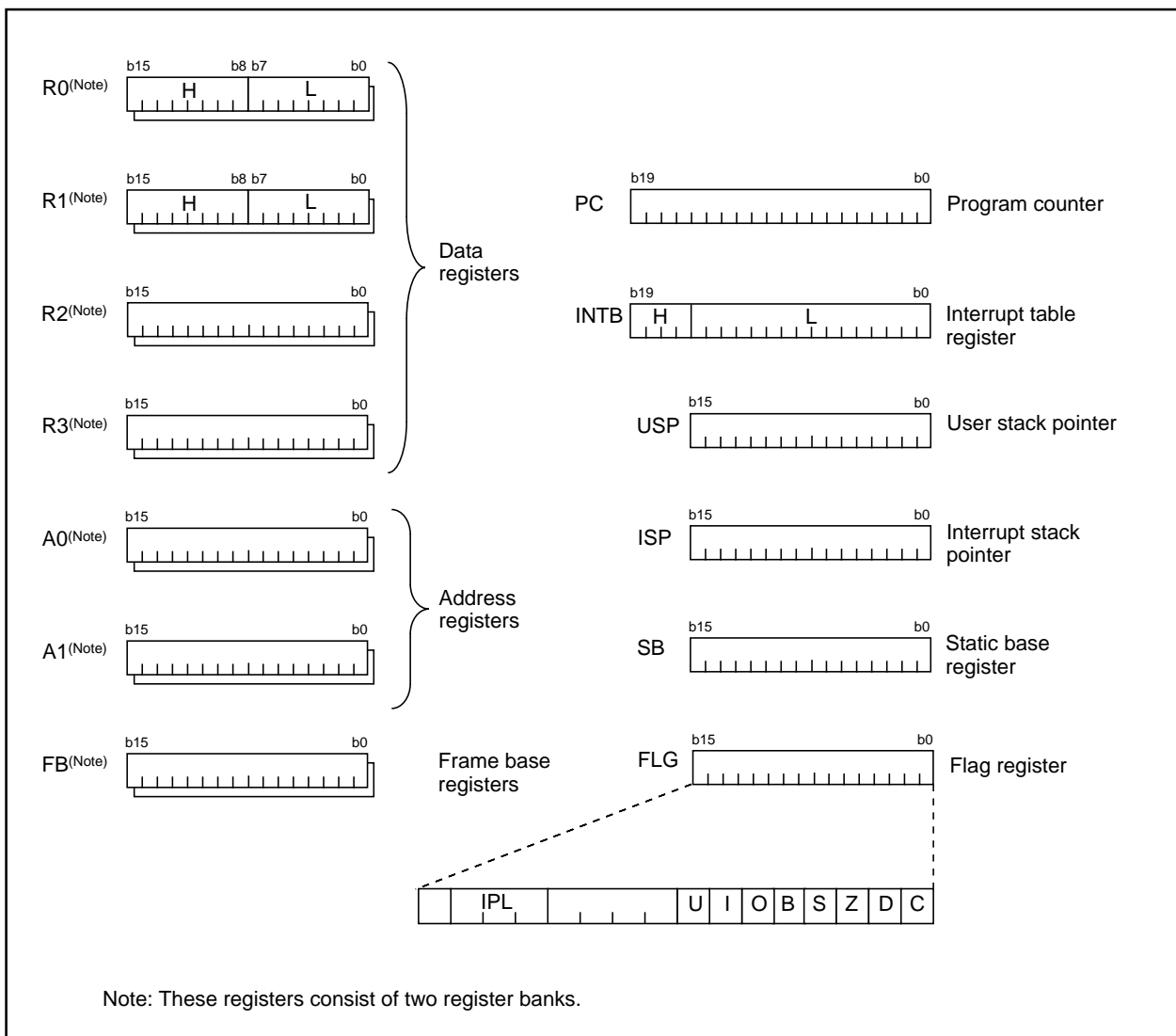

Figure 1.4.1. Central processing unit register

(1) Data registers (R0, R1, R1H, R2, and R3)

Data registers (R0, R1, R2, and R3) are configured with 16 bits, and are used primarily for transfer and arithmetic/logic operations.

Register R0 can be used as separate 8-bit data registers, R0H and R0L. Register R1 can be used as separate 8-bit data registers, R1H and R1L. In some instructions, registers R2 and R0, as well as R3 and R1 can use as 32-bit data registers (R2R0 or R3R1).

(2) Address registers (A0 and A1)

Address registers (A0 and A1) are configured with 16 bits, and have functions equivalent to those of data registers. These registers can also be used for address register indirect addressing and address register relative addressing.

In some instructions, registers A1 and A0 can be combined for use as a 32-bit address register (A1A0).

(3) Frame base register (FB)

Frame base register (FB) is configured with 16 bits, and is used for FB relative addressing.

(4) Program counter (PC)

Program counter (PC) is configured with 20 bits, indicating the address of an instruction to be executed.

(5) Interrupt table register (INTB)

Interrupt table register (INTB) is configured with 20 bits, indicating the start address of an interrupt vector table.

(6) Stack pointer (USP or ISP)

Stack pointer comes in two types: user stack pointer (USP) and interrupt stack pointer (ISP), each configured with 16 bits.

Your desired type of stack pointer (USP or ISP) can be selected by a stack pointer select flag (U flag).

This flag is located at the position of bit 7 in the flag register (FLG).

(7) Static base register (SB)

Static base register (SB) is configured with 16 bits, and is used for SB relative addressing.

(8) Flag register (FLG)

Flag register (FLG) is configured with 11 bits, each bit is used as a flag. Figure 1.4.2 shows the flag register (FLG). The following explains the function of each flag:

- **Bit 0: Carry flag (C flag)**

This flag retains a carry, borrow, or shift-out bit that has occurred in the arithmetic/logic unit.

- **Bit 1: Debug flag (D flag)**

This flag enables a single-step interrupt.

When this flag is "1", a single-step interrupt is generated after instruction execution. This flag is cleared to "0" when the interrupt is acknowledged.

- **Bit 2: Zero flag (Z flag)**

This flag is set to "1" when an arithmetic operation resulted in 0; otherwise, cleared to "0".

- **Bit 3: Sign flag (S flag)**

This flag is set to "1" when an arithmetic operation resulted in a negative value; otherwise, cleared to "0".

- **Bit 4: Register bank select flag (B flag)**

This flag chooses a register bank. Register bank 0 is selected when this flag is "0"; register bank 1 is selected when this flag is "1".

- **Bit 5: Overflow flag (O flag)**

This flag is set to "1" when an arithmetic operation resulted in overflow; otherwise, cleared to "0".

- **Bit 6: Interrupt enable flag (I flag)**

This flag enables a maskable interrupt.

An interrupt is disabled when this flag is "0", and is enabled when this flag is "1". This flag is cleared to "0" when the interrupt is acknowledged.

• **Bit 7: Stack pointer select flag (U flag)**

Interrupt stack pointer (ISP) is selected when this flag is “0” ; user stack pointer (USP) is selected when this flag is “1”.

This flag is cleared to “0” when a hardware interrupt is acknowledged or an INT instruction of software interrupt Nos. 0 to 31 is executed.

• **Bits 8 to 11: Reserved area**

• **Bits 12 to 14: Processor interrupt priority level (IPL)**

Processor interrupt priority level (IPL) is configured with three bits, for specification of up to eight processor interrupt priority levels from level 0 to level 7.

If a requested interrupt has priority greater than the processor interrupt priority level (IPL), the interrupt is enabled.

• **Bit 15: Reserved area**

The C, Z, S, and O flags are changed when instructions are executed. See the software manual for details.

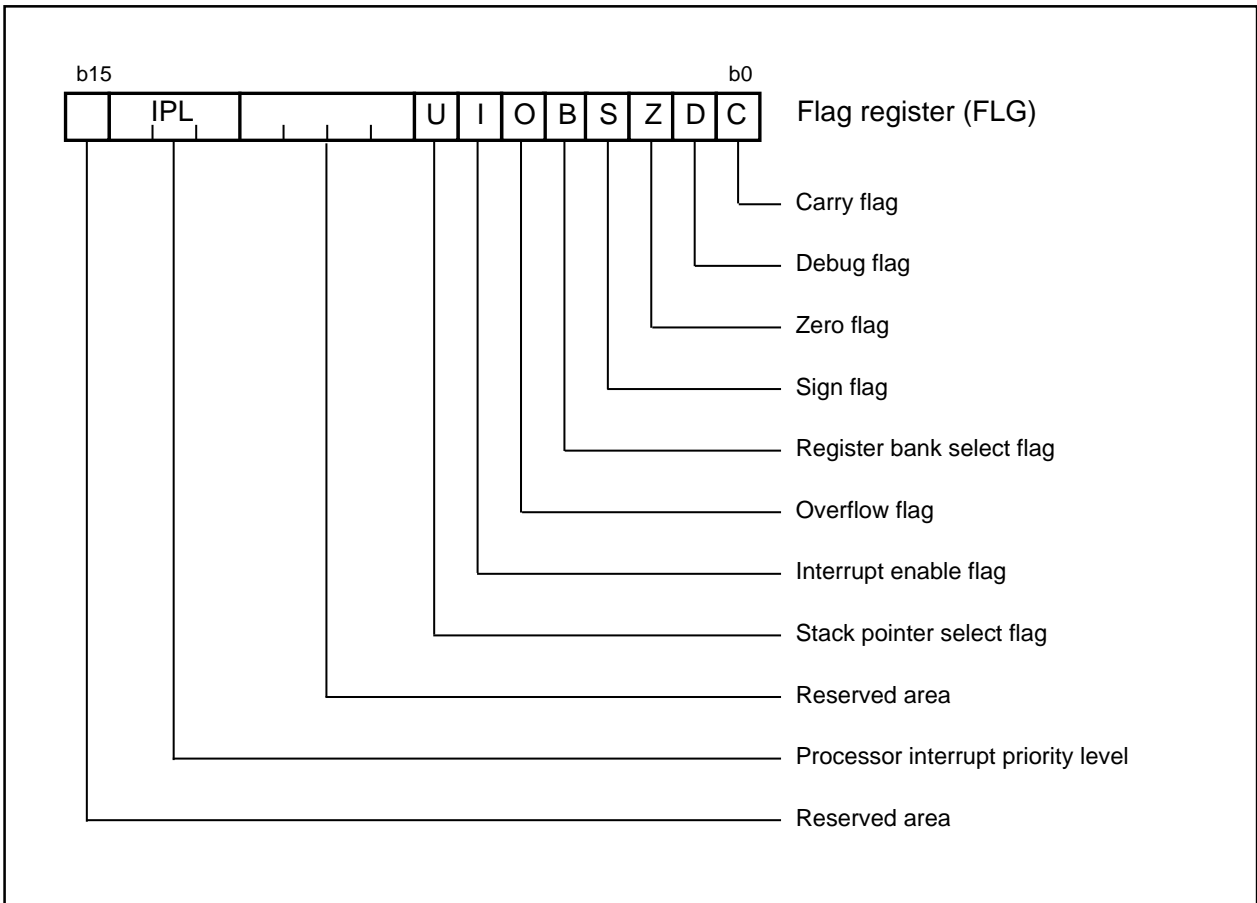

Figure 1.4.2. Flag register (FLG)

Reset

Reset

There are two kinds of resets; hardware and software. In both cases, operation is the same after the reset. (See "Software Reset" for details of software resets.) This section explains on hardware resets.

When the supply voltage is in the range where operation is guaranteed, a reset is effected by holding the reset pin level "L" (0.2V_{CC} max.) for at least 20 cycles. When the reset pin level is then returned to the "H" level while main clock is stable, the reset status is cancelled and program execution resumes from the address in the reset vector table.

The RAM is undefined at power on. The initial value must therefore be set. When a reset signal is applied while the CPU is writing a value to the RAM, the value may be set as unknown due to the termination of the CPU access.

Figure 1.5.1 shows the example reset circuit. Figure 1.5.2 shows the reset sequence.

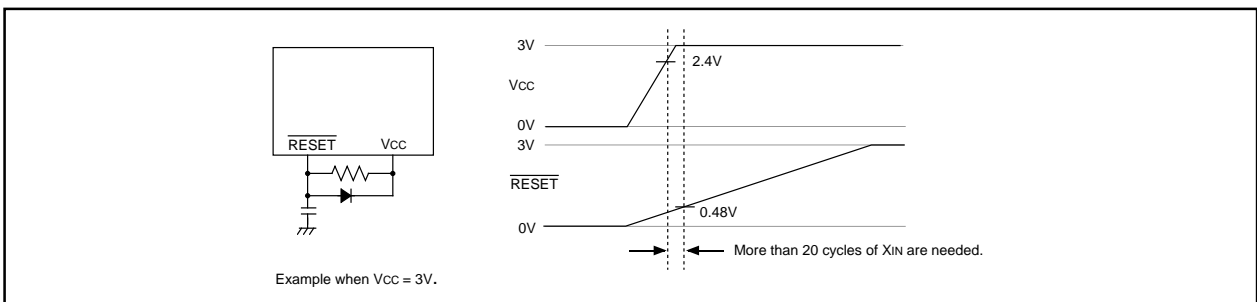

Figure 1.5.1. Example reset circuit

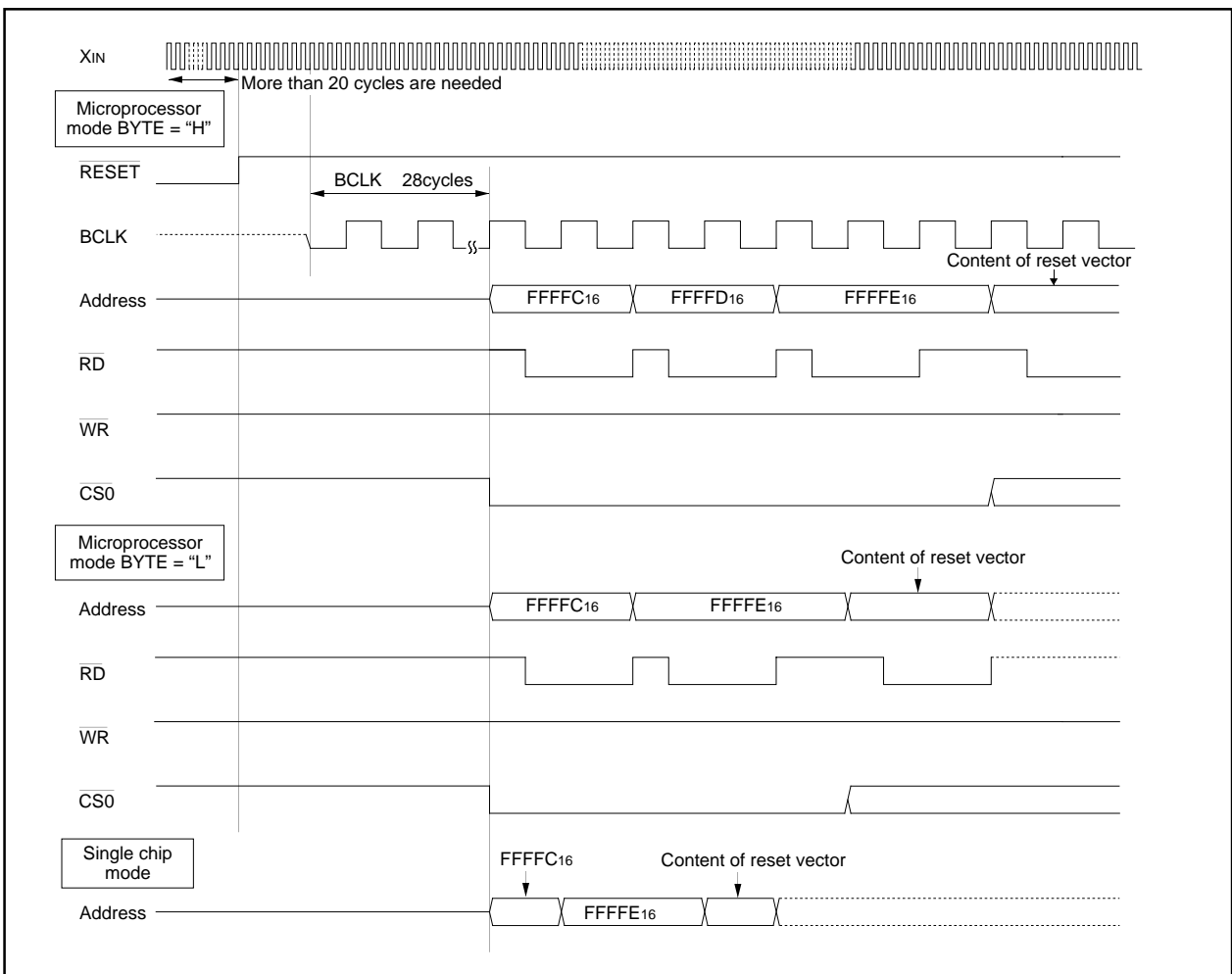

Figure 1.5.2. Reset sequence

Table 1.5.1 shows the statuses of the other pins while the $\overline{\text{RESET}}$ pin level is "L". Figures 1.5.3 and 1.5.4 show the internal status of the microcomputer immediately after the reset is cancelled.

Table 1.5.1. Pin status when $\overline{\text{RESET}}$ pin level is "L"

Pin name	Status		
	CNVss = Vss	CNVss = Vcc	
		BYTE = Vss	BYTE = Vcc
P0	Input port (floating)	Data input (floating)	Data input (floating)
P1	Input port (floating)	Data input (floating)	Input port (floating)
P2, P3, P40 to P43	Input port (floating)	Address output (undefined)	Address output (undefined)
P44	Input port (floating)	$\overline{\text{CS0}}$ output ("H" level is output)	$\overline{\text{CS0}}$ output ("H" level is output)
P45 to P47	Input port (floating)	Input port (floating) (pull-up resistor is on)	Input port (floating) (pull-up resistor is on)
P50	Input port (floating)	$\overline{\text{WR}}$ output ("H" level is output)	$\overline{\text{WR}}$ output ("H" level is output)
P51	Input port (floating)	$\overline{\text{BHE}}$ output (undefined)	$\overline{\text{BHE}}$ output (undefined)
P52	Input port (floating)	$\overline{\text{RD}}$ output ("H" level is output)	$\overline{\text{RD}}$ output ("H" level is output)
P53	Input port (floating)	BCLK output	BCLK output
P54	Input port (floating)	$\overline{\text{HLDA}}$ output (The output value depends on the input to the HOLD pin)	$\overline{\text{HLDA}}$ output (The output value depends on the input to the HOLD pin)
P55	Input port (floating)	HOLD input (floating)	HOLD input (floating)
P56	Input port (floating)	ALE output ("L" level is output)	ALE output ("L" level is output)
P57	Input port (floating)	$\overline{\text{RDY}}$ input (floating)	$\overline{\text{RDY}}$ input (floating)
P6, P7, P80 to P84, P86, P87, P9, P10	Input port (floating)	Input port (floating)	Input port (floating)

(1) Processor mode register 0 (Note)	(0004 ₁₆)...	00 ₁₆	(20) UART1 transmit interrupt control register	(0053 ₁₆)...	XXXXXXXX?000
(2) Processor mode register 1	(0005 ₁₆)...	0000000X0	(21) UART1 receive interrupt control register	(0054 ₁₆)...	XXXXXXXX?000
(3) System clock control register 0	(0006 ₁₆)...	010001000	(22) Timer A0 interrupt control register	(0055 ₁₆)...	XXXXXXXX?000
(4) System clock control register 1	(0007 ₁₆)...	001000000	(23) Timer A1 interrupt control register	(0056 ₁₆)...	XXXXXXXX?000
(5) Chip select control register	(0008 ₁₆)...	000000001	(24) Timer A2 interrupt control register	(0057 ₁₆)...	XXXXXXXX?000
(6) Address match interrupt enable register	(0009 ₁₆)...	XXXXXXXXX00	(25) Timer B1 interrupt control register	(005B ₁₆)...	XXXXXXXX?000
(7) Protect register	(000A ₁₆)...	XXXXXXXX000	(26) Timer B2 interrupt control register	(005C ₁₆)...	XXXXXXXX?000
(8) Watchdog timer control register	(000F ₁₆)...	000?? ?? ?	(27) INT0 interrupt control register	(005D ₁₆)...	XXXX00?000
(9) Address match interrupt register 0	(0010 ₁₆)...	00 ₁₆	(28) INT1 interrupt control register	(005E ₁₆)...	XXXX00?000
	(0011 ₁₆)...	00 ₁₆	(29) INT2 interrupt control register	(005F ₁₆)...	XXXX00?000
	(0012 ₁₆)...	XXXXXXXX0000	(30) Interrupt cause select register	(035F ₁₆)...	00 ₁₆
(10) Address match interrupt register 1	(0014 ₁₆)...	00 ₁₆	(31) UART2 special mode register 3	(0375 ₁₆)...	00 ₁₆
	(0015 ₁₆)...	00 ₁₆	(32) UART2 special mode register 2	(0376 ₁₆)...	00 ₁₆
	(0016 ₁₆)...	XXXXXXXX0000	(33) UART2 special mode register	(0377 ₁₆)...	80 ₁₆
(11) DMA0 control register	(002C ₁₆)...	000000?00	(34) UART2 transmit/receive mode register	(0378 ₁₆)...	00 ₁₆
(12) Bus collision detection interrupt control register	(004A ₁₆)...	XXXXXXXX?000	(35) UART2 transmit/receive control register 0	(037C ₁₆)...	0000010000
(13) DMA0 interrupt control register	(004B ₁₆)...	XXXXXXXX?000	(36) UART2 transmit/receive control register 1	(037D ₁₆)...	000000010
(14) Key input interrupt control register	(004D ₁₆)...	XXXXXXXX?000	(37) Count start flag	(0380 ₁₆)...	00 ₁₆
(15) A-D conversion interrupt control register	(004E ₁₆)...	XXXXXXXX?000	(38) Clock prescaler reset flag	(0381 ₁₆)...	0XXXXXXXXX
(16) UART2 transmit interrupt control register	(004F ₁₆)...	XXXXXXXX?000	(39) One-shot start flag	(0382 ₁₆)...	000000000
(17) UART2 receive interrupt control register	(0050 ₁₆)...	XXXXXXXX?000	(40) Trigger select flag	(0383 ₁₆)...	00 ₁₆
(18) UART0 transmit interrupt control register	(0051 ₁₆)...	XXXXXXXX?000	(41) Up-down flag	(0384 ₁₆)...	00 ₁₆
(19) UART0 receive interrupt control register	(0052 ₁₆)...	XXXXXXXX?000			

x : Nothing is mapped to this bit
? : Undefined

The content of other registers are undefined when the microcomputer is reset. The initial values must therefore be set. The RAM is undefined at power on. The initial values must therefore be set. When a reset signal is applied while the CPU is writing a value to the RAM, the value may be set as unknown due to the termination of the CPU access.

Note: When the VCC level is applied to the CNVSS pin, it is 0316 at a reset.

Figure 1.5.3. Device's internal status after a reset is cleared

(42) Timer A0 mode register	(0396 ₁₆)...	00 ₁₆	(62) Port P4 direction register	(03EA ₁₆)...	00 ₁₆
(43) Timer A1 mode register	(0397 ₁₆)...	00 ₁₆	(63) Port P5 direction register	(03EB ₁₆)...	00 ₁₆
(44) Timer A2 mode register	(0398 ₁₆)...	00 ₁₆	(64) Port P6 direction register	(03EE ₁₆)...	00 ₁₆
(45) Timer B1 mode register	(039C ₁₆)...	0 0 ? x 0 0 0 0	(65) Port P7 direction register	(03EF ₁₆)...	00 ₁₆
(46) Timer B2 mode register	(039D ₁₆)...	0 0 ? x 0 0 0 0	(66) Port P8 direction register	(03F2 ₁₆)...	0 0 x 0 0 0 0 0
(47) UART0 transmit/receive mode register	(03A0 ₁₆)...	00 ₁₆	(67) Port P9 direction register	(03F3 ₁₆)...	00 ₁₆
(48) UART0 transmit/receive control register 0	(03A4 ₁₆)...	0 0 0 0 1 0 0 0	(68) Port P10 direction register	(03F6 ₁₆)...	00 ₁₆
(49) UART0 transmit/receive control register 1	(03A5 ₁₆)...	0 0 0 0 0 0 1 0	(69) Pull-up control register 0	(03FC ₁₆)...	00 ₁₆
(50) UART1 transmit/receive mode register	(03A8 ₁₆)...	00 ₁₆	(70) Pull-up control register 1(Note)	(03FD ₁₆)...	00 ₁₆
(51) UART1 transmit/receive control register 0	(03AC ₁₆)...	0 0 0 0 1 0 0 0	(71) Pull-up control register 2	(03FE ₁₆)...	00 ₁₆
(52) UART1 transmit/receive control register 1	(03AD ₁₆)...	0 0 0 0 0 0 1 0	(72) Port control register	(03FF ₁₆)...	00 ₁₆
(53) UART transmit/receive control register 2	(03B0 ₁₆)...	x 0 0 0 0 0 0 0	(73) Data registers (R0/R1/R2/R3)		0000 ₁₆
(54) DMA0 cause select register	(03B8 ₁₆)...	00 ₁₆	(74) Address registers (A0/A1)		0000 ₁₆
(55) A-D control register 2	(03D4 ₁₆)...	0 0 0 0 ? ? ? 0	(75) Frame base register (FB)		0000 ₁₆
(56) A-D control register 0	(03D6 ₁₆)...	0 0 0 0 0 ? ? ?	(76) Interrupt table register (INTB)		00000 ₁₆
(57) A-D control register 1	(03D7 ₁₆)...	00 ₁₆	(77) User stack pointer (USP)		0000 ₁₆
(58) Port P0 direction register	(03E2 ₁₆)...	00 ₁₆	(78) Interrupt stack pointer (ISP)		0000 ₁₆
(59) Port P1 direction register	(03E3 ₁₆)...	00 ₁₆	(79) Static base register (SB)		0000 ₁₆
(60) Port P2 direction register	(03E6 ₁₆)...	00 ₁₆	(80) Flag register (FLG)		0000 ₁₆
(61) Port P3 direction register	(03E7 ₁₆)...	00 ₁₆			

x : Nothing is mapped to this bit
? : Undefined

The content of other registers are undefined when the microcomputer is reset. The initial values must therefore be set. The RAM is undefined at power on. The initial values must therefore be set. When a reset signal is applied while the CPU is writing a value to the RAM, the value may be set as unknown due to the termination of the CPU access.

Note: When the VCC level is applied to the CNVSS pin, it is 02₁₆ at a reset.

Figure 1.5.4. Device's internal status after a reset is cleared

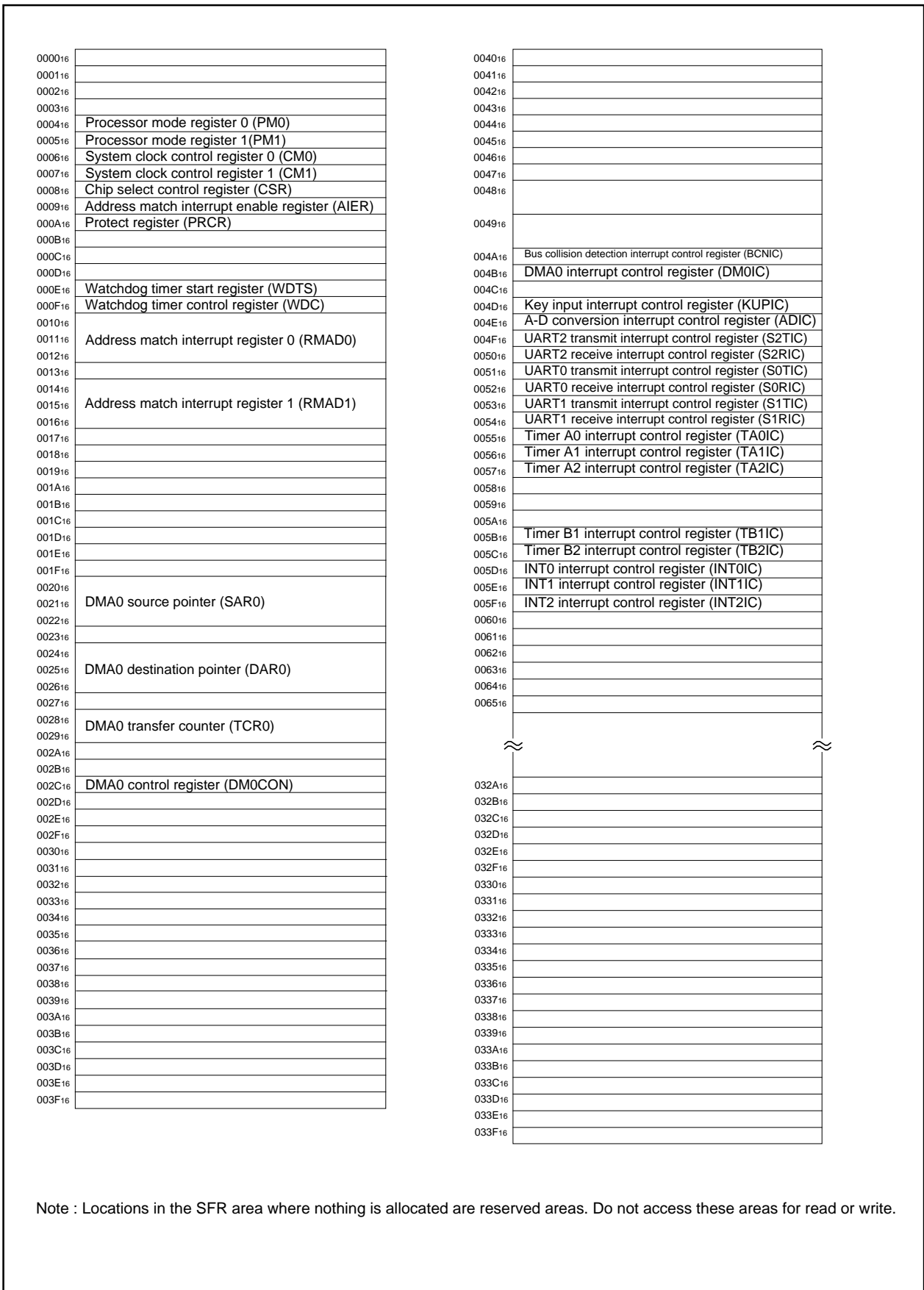

Figure 1.6.1. Location of peripheral unit control registers (1)

0340 ₁₆		0380 ₁₆	Count start flag (TABSR)	
0341 ₁₆		0381 ₁₆	Clock prescaler reset flag (CPSRF)	
0342 ₁₆		0382 ₁₆	One-shot start flag (ONSF)	
0343 ₁₆		0383 ₁₆	Trigger select register (TRGSR)	
0344 ₁₆		0384 ₁₆	Up-down flag (UDF)	
0345 ₁₆		0385 ₁₆		
0346 ₁₆		0386 ₁₆	Timer A0 register (TA0)	
0347 ₁₆		0387 ₁₆		
0348 ₁₆		0388 ₁₆	Timer A1 register (TA1)	
0349 ₁₆		0389 ₁₆		
034A ₁₆		038A ₁₆	Timer A2 register (TA2)	
034B ₁₆		038B ₁₆		
034C ₁₆		038C ₁₆		
034D ₁₆		038D ₁₆		
034E ₁₆		038E ₁₆		
034F ₁₆		038F ₁₆		
0350 ₁₆		0390 ₁₆		
0351 ₁₆		0391 ₁₆		
0352 ₁₆		0392 ₁₆	Timer B1 register (TB1)	
0353 ₁₆		0393 ₁₆		
0354 ₁₆		0394 ₁₆	Timer B2 register (TB2)	
0355 ₁₆		0395 ₁₆		
0356 ₁₆		0396 ₁₆	Timer A0 mode register (TA0MR)	
0357 ₁₆		0397 ₁₆	Timer A1 mode register (TA1MR)	
0358 ₁₆		0398 ₁₆	Timer A2 mode register (TA2MR)	
0359 ₁₆		0399 ₁₆		
035A ₁₆		039A ₁₆		
035B ₁₆		039B ₁₆		
035C ₁₆		039C ₁₆	Timer B1 mode register (TB1MR)	
035D ₁₆		039D ₁₆	Timer B2 mode register (TB2MR)	
035E ₁₆		039E ₁₆		
035F ₁₆	Interrupt cause select register (IFSR)	039F ₁₆		
0360 ₁₆		03A0 ₁₆	UART0 transmit/receive mode register (U0MR)	
0361 ₁₆		03A1 ₁₆	UART0 bit rate generator (U0BRG)	
0362 ₁₆		03A2 ₁₆	UART0 transmit buffer register (U0TB)	
0363 ₁₆		03A3 ₁₆		
0364 ₁₆		03A4 ₁₆	UART0 transmit/receive control register 0 (U0C0)	
0365 ₁₆		03A5 ₁₆	UART0 transmit/receive control register 1 (U0C1)	
0366 ₁₆		03A6 ₁₆	UART0 receive buffer register (U0RB)	
0367 ₁₆		03A7 ₁₆		
0368 ₁₆		03A8 ₁₆	UART1 transmit/receive mode register (U1MR)	
0369 ₁₆		03A9 ₁₆	UART1 bit rate generator (U1BRG)	
036A ₁₆		03AA ₁₆	UART1 transmit buffer register (U1TB)	
036B ₁₆		03AB ₁₆		
036C ₁₆		03AC ₁₆	UART1 transmit/receive control register 0 (U1C0)	
036D ₁₆		03AD ₁₆	UART1 transmit/receive control register 1 (U1C1)	
036E ₁₆		03AE ₁₆	UART1 receive buffer register (U1RB)	
036F ₁₆		03AF ₁₆		
0370 ₁₆		03B0 ₁₆	UART transmit/receive control register 2 (U0CON)	
0371 ₁₆		03B1 ₁₆		
0372 ₁₆		03B2 ₁₆		
0373 ₁₆		03B3 ₁₆		
0374 ₁₆		03B4 ₁₆		
0375 ₁₆	UART2 special mode register 3(U2SMR3)	03B5 ₁₆		
0376 ₁₆	UART2 special mode register 2(U2SMR2)	03B6 ₁₆		
0377 ₁₆	UART2 special mode register (U2SMR)	03B7 ₁₆		
0378 ₁₆	UART2 transmit/receive mode register (U2MR)	03B8 ₁₆	DMA0 request cause select register (DM0SL)	
0379 ₁₆	UART2 bit rate generator (U2BRG)	03B9 ₁₆		
037A ₁₆	UART2 transmit buffer register (U2TB)	03BA ₁₆		
037B ₁₆			03BB ₁₆	
037C ₁₆	UART2 transmit/receive control register 0 (U2C0)	03BC ₁₆		
037D ₁₆	UART2 transmit/receive control register 1 (U2C1)	03BD ₁₆		
037E ₁₆	UART2 receive buffer register (U2RB)	03BE ₁₆		
037F ₁₆			03BF ₁₆	

Note : Locations in the SFR area where nothing is allocated are reserved areas. Do not access these areas for read or write.

Figure 1.6.2. Location of peripheral unit control registers (2)

03C0 ₁₆	A-D register 0 (AD0)
03C1 ₁₆	
03C2 ₁₆	A-D register 1 (AD1)
03C3 ₁₆	
03C4 ₁₆	A-D register 2 (AD2)
03C5 ₁₆	
03C6 ₁₆	A-D register 3 (AD3)
03C7 ₁₆	
03C8 ₁₆	A-D register 4 (AD4)
03C9 ₁₆	
03CA ₁₆	A-D register 5 (AD5)
03CB ₁₆	
03CC ₁₆	A-D register 6 (AD6)
03CD ₁₆	
03CE ₁₆	A-D register 7 (AD7)
03CF ₁₆	
03D0 ₁₆	
03D1 ₁₆	
03D2 ₁₆	
03D3 ₁₆	
03D4 ₁₆	A-D control register 2 (ADCON2)
03D5 ₁₆	
03D6 ₁₆	A-D control register 0 (ADCON0)
03D7 ₁₆	A-D control register 1 (ADCON1)
03D8 ₁₆	
03D9 ₁₆	
03DA ₁₆	
03DB ₁₆	
03DC ₁₆	
03DD ₁₆	
03DE ₁₆	
03DF ₁₆	
03E0 ₁₆	Port P0 register (P0)
03E1 ₁₆	Port P1 register (P1)
03E2 ₁₆	Port P0 direction register (PD0)
03E3 ₁₆	Port P1 direction register (PD1)
03E4 ₁₆	Port P2 register (P2)
03E5 ₁₆	Port P3 register (P3)
03E6 ₁₆	Port P2 direction register (PD2)
03E7 ₁₆	Port P3 direction register (PD3)
03E8 ₁₆	Port P4 register (P4)
03E9 ₁₆	Port P5 register (P5)
03EA ₁₆	Port P4 direction register (PD4)
03EB ₁₆	Port P5 direction register (PD5)
03EC ₁₆	Port P6 register (P6)
03ED ₁₆	Port P7 register (P7)
03EE ₁₆	Port P6 direction register (PD6)
03EF ₁₆	Port P7 direction register (PD7)
03F0 ₁₆	Port P8 register (P8)
03F1 ₁₆	Port P9 register (P9)
03F2 ₁₆	Port P8 direction register (PD8)
03F3 ₁₆	Port P9 direction register (PD9)
03F4 ₁₆	Port P10 register (P10)
03F5 ₁₆	
03F6 ₁₆	Port P10 direction register (PD10)
03F7 ₁₆	
03F8 ₁₆	
03F9 ₁₆	
03FA ₁₆	
03FB ₁₆	
03FC ₁₆	Pull-up control register 0 (PUR0)
03FD ₁₆	Pull-up control register 1 (PUR1)
03FE ₁₆	Pull-up control register 2 (PUR2)
03FF ₁₆	Port control register (PCR)

Note : Locations in the SFR area where nothing is allocated are reserved areas. Do not access these areas for read or write.

Figure 1.6.3. Location of peripheral unit control registers (3)

Software Reset

Writing “1” to bit 3 of the processor mode register 0 (address 000416) applies a (software) reset to the microcomputer. A software reset has the same effect as a hardware reset. The contents of internal RAM are preserved.

Processor Mode

(1) Types of Processor Mode

One of three processor modes can be selected: single-chip mode, memory expansion mode, and microprocessor mode. The functions of some pins, the memory map, and the access space differ according to the selected processor mode.

- **Single-chip mode**

In single-chip mode, only internal memory space (SFR, internal RAM, and internal ROM) can be accessed. However, after the reset has been released and the operation of shifting from the microprocessor mode has started (“H” applied to the CNVss pin), the internal ROM area cannot be accessed even if the CPU shifts to the single-chip mode.

Ports P0 to P10 can be used as programmable I/O ports or as I/O ports for the internal peripheral functions.

- **Memory expansion mode**

In memory expansion mode, external memory can be accessed in addition to the internal memory space (SFR, internal RAM, and internal ROM). However, after the reset has been released and the operation of shifting from the microprocessor mode has started (“H” applied to the CNVss pin), the internal ROM area cannot be accessed even if the CPU shifts to the memory expansion mode.

In this mode, some of the pins function as the address bus, the data bus, and as control signals. The number of pins assigned to these functions depends on the bus and register settings. (See “Bus Settings” for details.)

- **Microprocessor mode**

In microprocessor mode, the SFR, internal RAM, and external memory space can be accessed. The internal ROM area cannot be accessed.

In this mode, some of the pins function as the address bus, the data bus, and as control signals. The number of pins assigned to these functions depends on the bus width and register settings. (See “Bus Settings” for details.)

(2) Setting Processor Modes

The processor mode is set using the CNVss pin and the processor mode bits (bits 1 and 0 at address 000416). Do not set the processor mode bits to “102”.

Regardless of the level of the CNVss pin, changing the processor mode bits selects the mode. Therefore, never change the processor mode bits when changing the contents of other bits. Do not change the processor mode bits simultaneously with other bits when changing the processor mode bits “012” or “112”. Change the processor mode bits after changing the other bits. Also do not attempt to shift to or from the microprocessor mode within the program stored in the internal ROM area.

- **Applying Vss to CNVss pin**

The microcomputer begins operation in single-chip mode after being reset. Memory expansion mode is selected by writing “012” to the processor mode bits.

- **Applying Vcc to CNVss pin**

The microcomputer starts to operate in microprocessor mode after being reset.

Processor Mode

Figure 1.7.1 shows the processor mode register 0 and 1.

Figure 1.7.2 shows the memory maps in each processor modes.

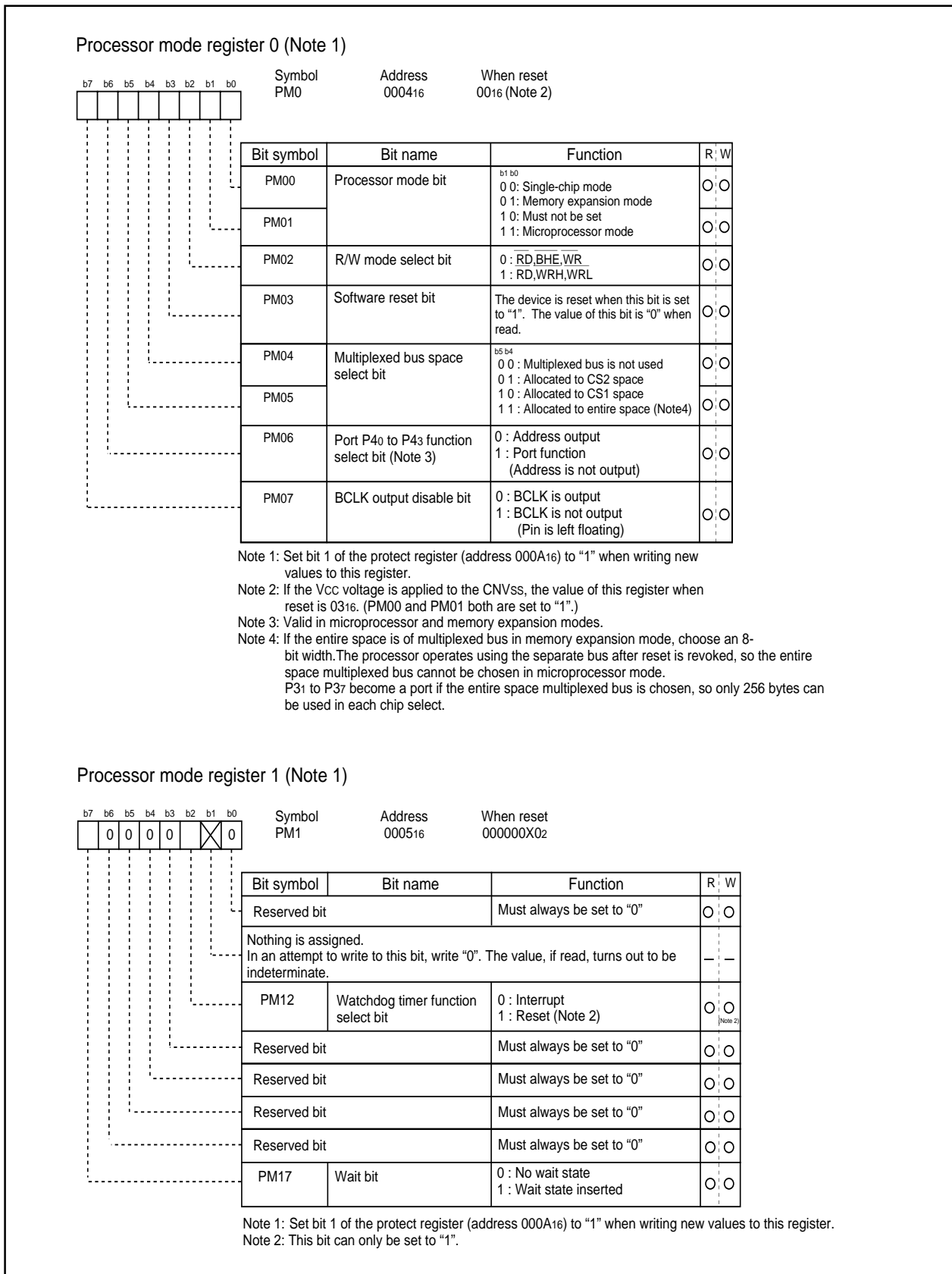

Figure 1.7.1. Processor mode register 0 and 1

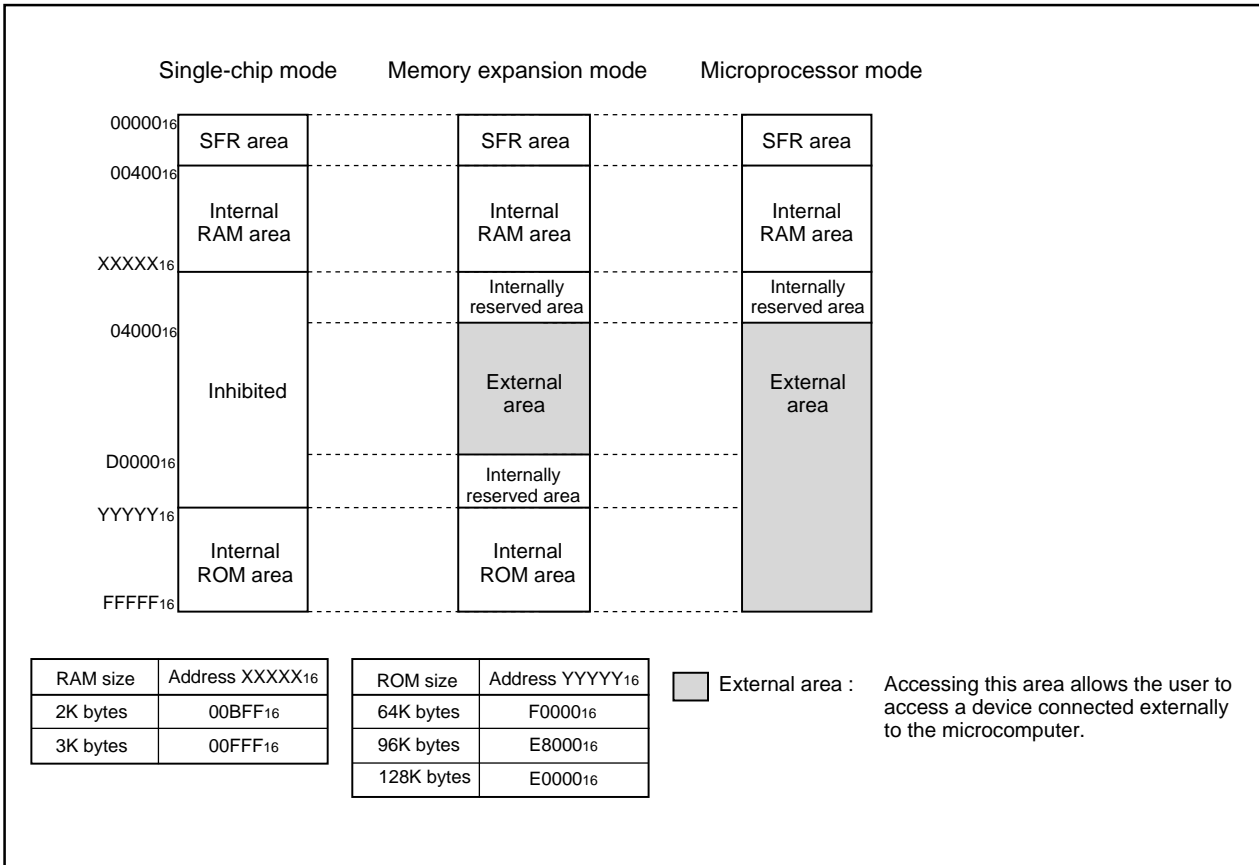

Figure 1.7.2. Memory maps in each processor modes

Bus Settings

The BYTE pin and bits 4 to 6 of the processor mode register 0 (address 000416) are used to change the bus settings. Table 1.8.1 shows the factors used to change the bus settings.

Table 1.8.1. Factors for switching bus settings

Bus setting	Switching factor
Switching external address bus width	Bit 6 of processor mode register 0
Switching external data bus width	BYTE pin
Switching between separate and multiplex bus	Bits 4 and 5 of processor mode register 0

(1) Selecting external address bus width

The address bus width for external output in the 1M bytes of address space can be set to 16 bits (64K bytes address space) or 20 bits (1M bytes address space). When bit 6 of the processor mode register 0 is set to "1", the external address bus width is set to 16 bits, and P2 and P3 become part of the address bus. P40 to P43 can be used as programmable I/O ports. When bit 6 of processor mode register 0 is set to "0", the external address bus width is set to 20 bits, and P2, P3, and P40 to P43 become part of the address bus.

(2) Selecting external data bus width

The external data bus width can be set to 8 or 16 bits. (Note, however, that only the separate bus can be set.) When the BYTE pin is "L", the bus width is set to 16 bits; when "H", it is set to 8 bits. (The internal bus width is permanently set to 16 bits.) While operating, fix the BYTE pin either to "H" or to "L".

(3) Selecting separate/multiplex bus

The bus format can be set to multiplex or separate bus using bits 4 and 5 of the processor mode register 0.

- **Separate bus**

In this mode, the data and address are input and output separately. The data bus can be set using the BYTE pin to be 8 or 16 bits. When the BYTE pin is "H", the data bus is set to 8 bits and P0 functions as the data bus and P1 as a programmable I/O port. When the BYTE pin is "L", the data bus is set to 16 bits and P0 and P1 are both used for the data bus.

When the separate bus is used for access, a software wait can be selected.

- **Multiplex bus**

In this mode, data and address I/O are time multiplexed. With the BYTE pin = "H", the 8 bits from D0 to D7 are multiplexed with A0 to A7.

With the BYTE pin = "L", the 8 bits from D0 to D7 are multiplexed with A1 to A8. D8 to D15 are not multiplexed. In this case, the external devices connected to the multiplexed bus are mapped to the microcomputer's even addresses (every 2nd address). To access these external devices, access the even addresses as bytes.

The ALE signal latches the address. It is output from P56.

Before using the multiplex bus for access, be sure to insert a software wait.

If the entire space is of multiplexed bus in memory expansion mode, choose an 8-bit width.

The processor operates using the separate bus after reset is revoked, so the entire space multiplexed bus cannot be chosen in microprocessor mode.

P31 to P37 become a port if the entire space multiplexed bus is chosen, so only 256 bytes can be used in each chip select.

Table 1.8.2. Pin functions for each processor mode

Processor mode	Single-chip mode	Memory expansion mode/microprocessor modes				Memory expansion mode
Multiplexed bus space select bit	/	"01", "10" [Either CS1 or CS2 is for multiplexed bus and others are for separate bus]		"00" (separate bus)		"11" (Note 1) [multiplexed bus for the entire space]
Data bus width BYTE pin level		8 bits "H"	16 bits "L"	8 bits "H"	16 bits "L"	8 bit "H"
P00 to P07	I/O port	Data bus	Data bus	Data bus	Data bus	I/O port
P10 to P17	I/O port	I/O port	Data bus	I/O port	Data bus	I/O port
P20	I/O port	Address bus /data bus(Note 2)	Address bus	Address bus	Address bus	Address bus /data bus
P21 to P27	I/O port	Address bus /data bus(Note 2)	Address bus /data bus(Note 2)	Address bus	Address bus	Address bus /data bus
P30	I/O port	Address bus	Address bus /data bus(Note 2)	Address bus	Address bus	A8/D7
P31 to P37	I/O port	Address bus	Address bus	Address bus	Address bus	I/O port
P40 to P43 Port P40 to P43 function select bit = 1	I/O port	I/O port	I/O port	I/O port	I/O port	I/O port
P40 to P43 Port P40 to P43 function select bit = 0	I/O port	Address bus	Address bus	Address bus	Address bus	I/O port
P44 to P47	I/O port	\overline{CS} (chip select) or programmable I/O port (For details, refer to "Bus control")				
P50 to P53	I/O port	Outputs \overline{RD} , \overline{WRL} , \overline{WRH} , and \overline{BCLK} or \overline{RD} , \overline{BHE} , \overline{WR} , and \overline{BCLK} (For details, refer to "Bus control")				
P54	I/O port	\overline{HLDA}	\overline{HLDA}	\overline{HLDA}	\overline{HLDA}	\overline{HLDA}
P55	I/O port	\overline{HOLD}	\overline{HOLD}	\overline{HOLD}	\overline{HOLD}	\overline{HOLD}
P56	I/O port	ALE	ALE	ALE	ALE	ALE
P57	I/O port	\overline{RDY}	\overline{RDY}	\overline{RDY}	\overline{RDY}	\overline{RDY}

Note 1: If the entire space is of multiplexed bus in memory expansion mode, choose an 8-bit width.
 The processor operates using the separate bus after reset is revoked, so the entire space multiplexed bus cannot be chosen in microprocessor mode.
 P31 to P37 become a port if the entire space multiplexed bus is chosen, so only 256 bytes can be used in each chip select.

Note 2: Address bus when in separate bus mode.

Bus Control

The following explains the signals required for accessing external devices and software waits. The signals required for accessing the external devices are valid when the processor mode is set to memory expansion mode and microprocessor mode. The software waits are valid in all processor modes.

(1) Address bus/data bus

The address bus consists of the 20 pins A0 to A19 for accessing the 1M bytes of address space.

The data bus consists of the pins for data I/O. When the BYTE pin is "H", the 8 ports D0 to D7 function as the data bus. When BYTE is "L", the 16 ports D0 to D15 function as the data bus.

When a change is made from single-chip mode to memory expansion mode, the value of the address bus is undefined until external memory is accessed.

(2) Chip select signal

The chip select signal is output using the same pins as P44 to P47. Bits 0 to 3 of the chip select control register (address 0008₁₆) set each pin to function as a port or to output the chip select signal. The chip select control register is valid in memory expansion mode and microprocessor mode. In single-chip mode, P44 to P47 function as programmable I/O ports regardless of the value in the chip select control register.

In microprocessor mode, only $\overline{CS0}$ outputs the chip select signal after the reset state has been cancelled. $\overline{CS1}$ to $\overline{CS3}$ function as input ports. Figure 1.9.1 shows the chip select control register.

The chip select signal can be used to split the external area into as many as four blocks. Tables 1.9.1 shows the external memory areas specified using the chip select signal.

Table 1.9.1. External areas specified by the chip select signals

Processor mode	Chip select signal			
	$\overline{CS0}$	$\overline{CS1}$	$\overline{CS2}$	$\overline{CS3}$
Memory expansion mode	30000 ₁₆ to CFFFF ₁₆ (640K bytes)	28000 ₁₆ to 2FFFF ₁₆ (32K bytes)	08000 ₁₆ to 27FFF ₁₆ (128K bytes)	04000 ₁₆ to 07FFF ₁₆ (16K bytes)
Microprocessor mode	30000 ₁₆ to FFFFF ₁₆ (832K bytes)			

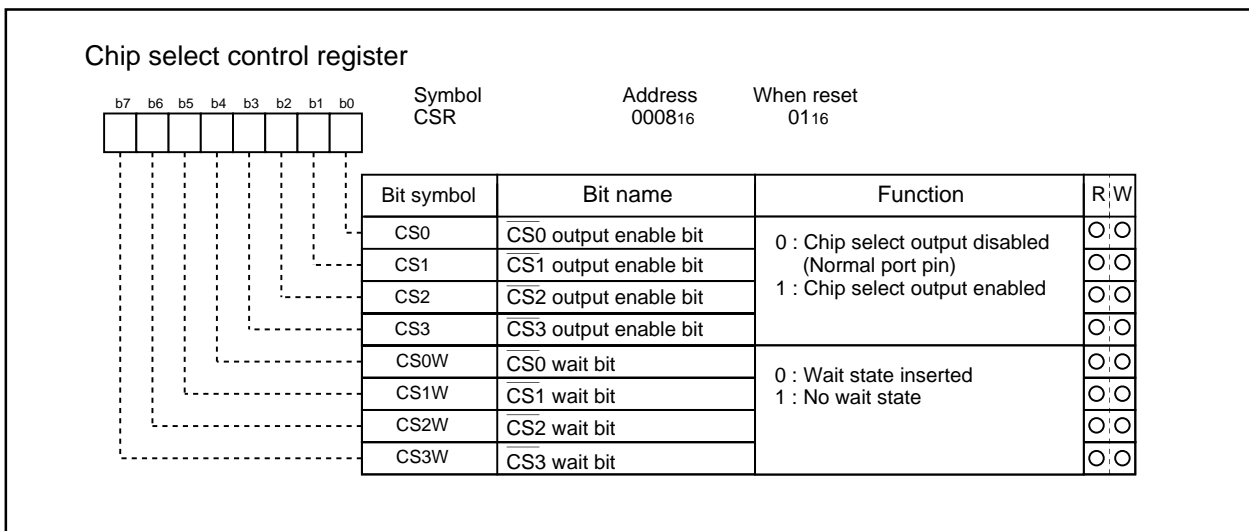

Figure 1.9.1. Chip select control register

The timing of the chip select signal changing to “L”(active) is synchronized with the address bus. But the timing of the chip select signal changing to “H” depends on the area which will be accessed in the next cycle. Figure 1.9.2 shows the output example of the address bus and chip select signal.

Bus Control

Example 1) After access the external area, both the address signal and the chip select signal change concurrently in the next cycle.

In this example, after access to the external area(i), an access to the area indicated by the other chip select signal(j) will occur in the next cycle. In this case, both the address bus and the chip select signal change between the two cycles.

Example 2) After access the external area, only the chip select signal changes in the next cycle (the address bus does not change).

In this example, an access to the internal ROM or the internal RAM in the next cycle will occur, after access to the external area. In this case, the chip select signal changes between the two cycles, but the address does not change.

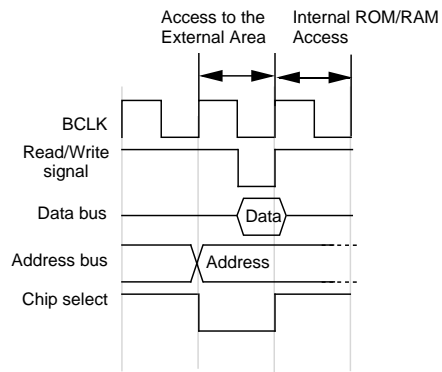
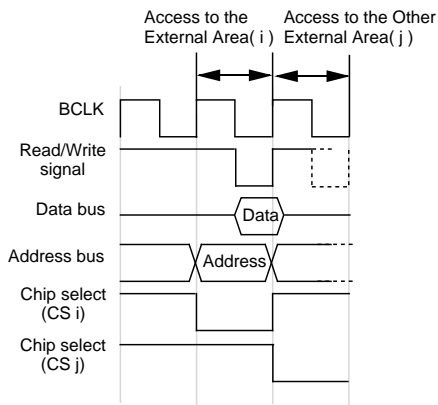

Example 3) After access the external area, only the address bus changes in the next cycle (the chip select signal does not change).

In this example, after access to the external area(i), an access to the area indicated by the same chip select signal(i) will occur in the next cycle. In this case, the address bus changes between the two cycles, but the chip select signal does not change.

Example 4) After access the external area, either the address signal and the chip select signal do not change in the next cycle.

In this example, any access to any area does not occur in the next cycle (either instruction prefetch does not occur). In this case, either the address bus and chip select signal do not change between the two cycles.

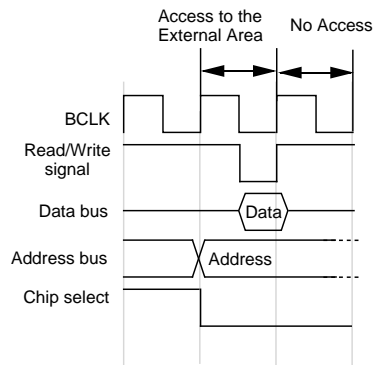
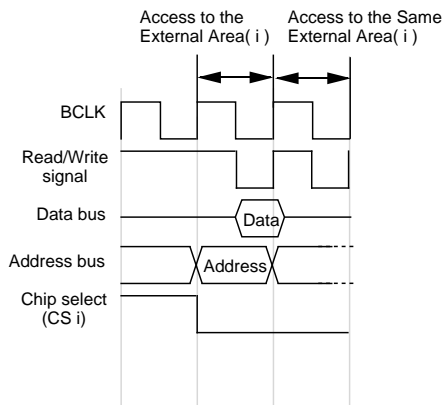

Note : These examples show the address bus and chip select signal within the successive two cycles. According to the combination of these examples, the chip select can be elongated to over 2cycles.

Figure 1.9.2. Output Examples about Address Bus and Chip Select Signal (Separated Bus without Wait)

(3) Read/write signals

With a 16-bit data bus (BYTE pin = "L"), bit 2 of the processor mode register 0 (address 0004₁₆) select the combinations of \overline{RD} , \overline{BHE} , and \overline{WR} signals or \overline{RD} , \overline{WRL} , and \overline{WRH} signals. With an 8-bit data bus (BYTE pin = "H"), use the combination of \overline{RD} , \overline{WR} , and \overline{BHE} signals. (Set bit 2 of the processor mode register 0 (address 0004₁₆) to "0".) Tables 1.9.3 and 1.9.4 show the operation of these signals.

After a reset has been cancelled, the combination of \overline{RD} , \overline{WR} , and \overline{BHE} signals is automatically selected. When switching to the \overline{RD} , \overline{WRL} , and \overline{WRH} combination, do not write to external memory until bit 2 of the processor mode register 0 (address 0004₁₆) has been set (Note).

Note: Before attempting to change the contents of the processor mode register 0, set bit 1 of the protect register (address 000A₁₆) to "1".

Table 1.9.3. Operation of \overline{RD} , \overline{WRL} , and \overline{WRH} signals

Data bus width	\overline{RD}	\overline{WRL}	\overline{WRH}	Status of external data bus
16-bit (BYTE = "L")	L	H	H	Read data
	H	L	H	Write 1 byte of data to even address
	H	H	L	Write 1 byte of data to odd address
	H	L	L	Write data to both even and odd addresses

Table 1.9.4. Operation of \overline{RD} , \overline{WR} , and \overline{BHE} signals

Data bus width	\overline{RD}	\overline{WR}	\overline{BHE}	A0	Status of external data bus
16-bit (BYTE = "L")	H	L	L	H	Write 1 byte of data to odd address
	L	H	L	H	Read 1 byte of data from odd address
	H	L	H	L	Write 1 byte of data to even address
	L	H	H	L	Read 1 byte of data from even address
	H	L	L	L	Write data to both even and odd addresses
	L	H	L	L	Read data from both even and odd addresses
8-bit (BYTE = "H")	H	L	Not used	H / L	Write 1 byte of data
	L	H	Not used	H / L	Read 1 byte of data

(4) ALE signal

The ALE signal latches the address when accessing the multiplex bus space. Latch the address when the ALE signal falls.

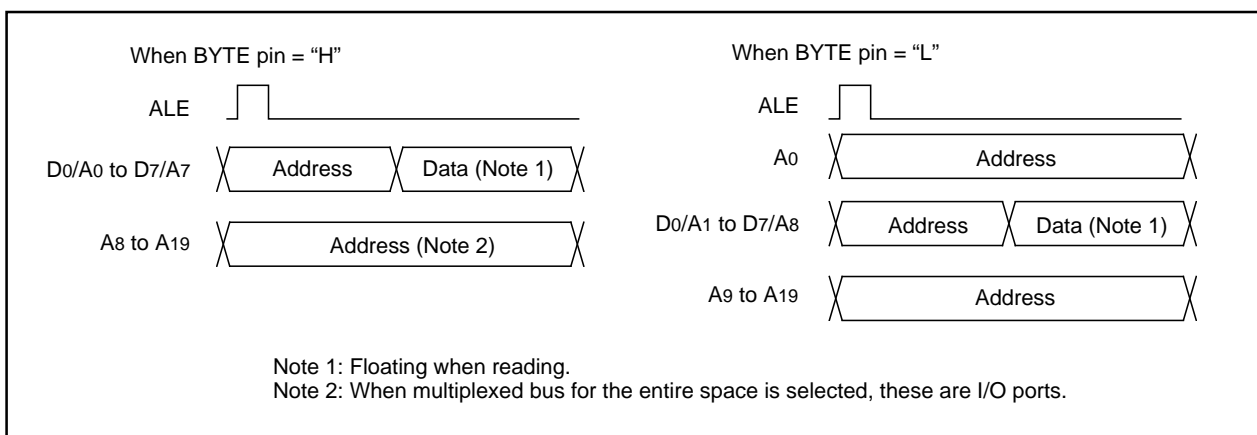

Figure 1.9.3. ALE signal and address/data bus

(5) The \overline{RDY} signal

\overline{RDY} is a signal that facilitates access to an external device that requires long access time. As shown in Figure 1.9.4, if an “L” is being input to the \overline{RDY} at the BCLK falling edge, the bus turns to the wait state. If an “H” is being input to the \overline{RDY} pin at the BCLK falling edge, the bus cancels the wait state. Table 1.9.5 shows the state of the microcomputer with the bus in the wait state, and Figure 1.9.4 shows an example in which the \overline{RD} signal is prolonged by the \overline{RDY} signal.

The \overline{RDY} signal is valid when accessing the external area during the bus cycle in which bits 4 to 7 of the chip select control register (address 000816) are set to “0”. The \overline{RDY} signal is invalid when setting “1” to all bits 4 to 7 of the chip select control register (address 000816), but the \overline{RDY} pin should be treated as properly as in non-using.

Table 1.9.5. Microcomputer status in wait state (Note)

Item	Status
Oscillation	On
R/W signal, address bus, data bus, \overline{CS} ALE signal, \overline{HLDA} , programmable I/O ports	Maintain status when \overline{RDY} signal received
Internal peripheral circuits	On

Note: The \overline{RDY} signal cannot be received immediately prior to a software wait.

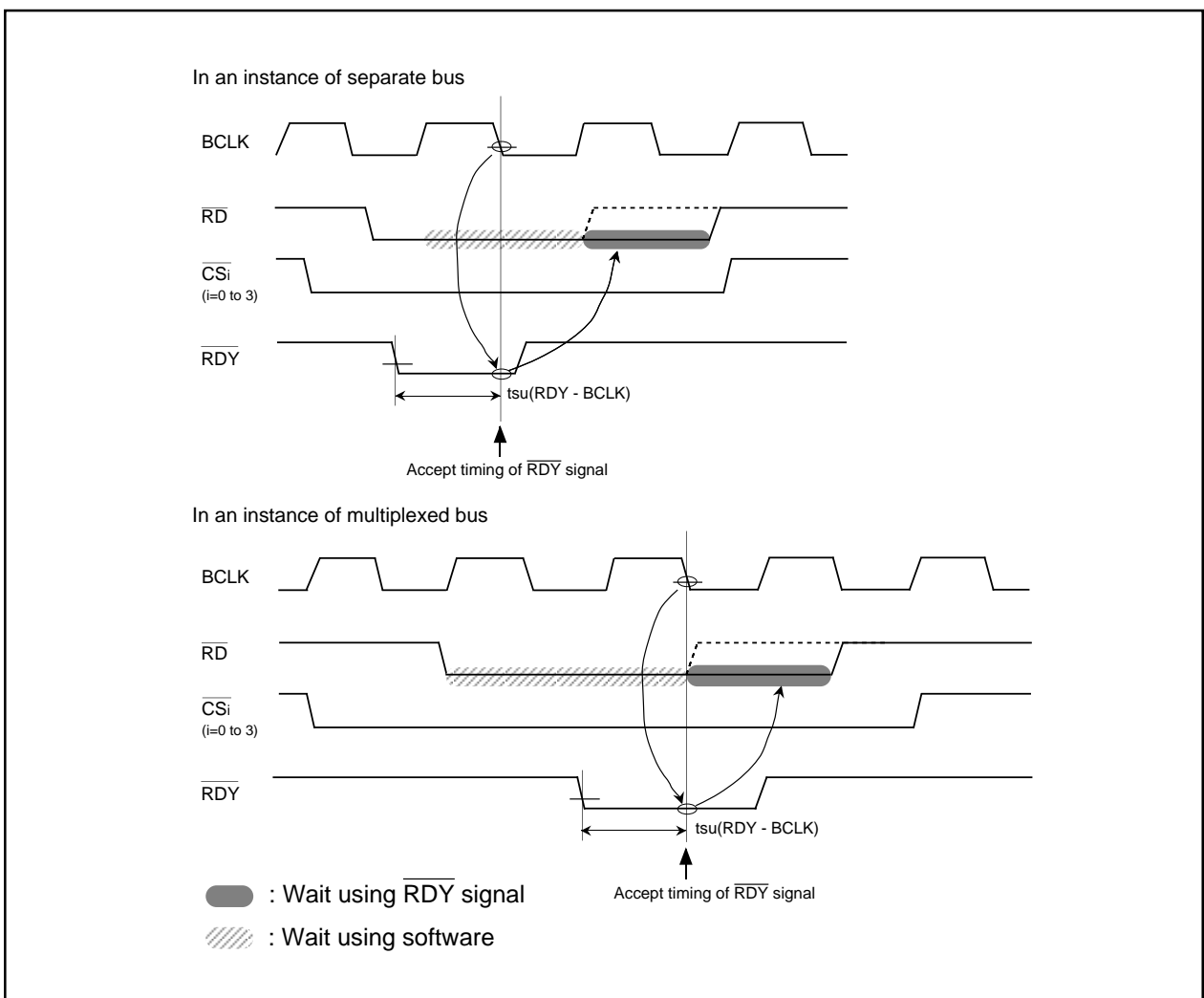

Figure 1.9.4. Example of \overline{RD} signal extended by \overline{RDY} signal

(6) Hold signal

The hold signal is used to transfer the bus privileges from the CPU to the external circuits. Inputting “L” to the $\overline{\text{HOLD}}$ pin places the microcomputer in the hold state at the end of the current bus access. This status is maintained and “L” is output from the $\overline{\text{HLDA}}$ pin as long as “L” is input to the $\overline{\text{HOLD}}$ pin. Table 1.9.6 shows the microcomputer status in the hold state.

Bus-using priorities are given to $\overline{\text{HOLD}}$, DMAC, and CPU in order of decreasing precedence.



Figure 1.9.5. Bus-using priorities

Table 1.9.6. Microcomputer status in hold state

Item		Status
Oscillation		ON
R/ $\overline{\text{W}}$ signal, address bus, data bus, $\overline{\text{CS}}$, $\overline{\text{BHE}}$		Floating
Programmable I/O ports	P0, P1, P2, P3, P4, P5	Floating
	P6, P7, P8, P9, P10	Maintains status when hold signal is received
$\overline{\text{HLDA}}$		Output “L”
Internal peripheral circuits		ON (but watchdog timer stops)
ALE signal		Undefined

(7) External bus status when the internal area is accessed

Table 1.9.7 shows the external bus status when the internal area is accessed.

Table 1.9.7. External bus status when the internal area is accessed

Item		SFR accessed	Internal ROM/RAM accessed
Address bus		Address output	Maintain status before accessed address of external area
Data bus	When read	Floating	Floating
	When write	Output data	Undefined
$\overline{\text{RD}}$, $\overline{\text{WR}}$, $\overline{\text{WRL}}$, $\overline{\text{WRH}}$		$\overline{\text{RD}}$, $\overline{\text{WR}}$, $\overline{\text{WRL}}$, $\overline{\text{WRH}}$ output	Output “H”
$\overline{\text{BHE}}$		$\overline{\text{BHE}}$ output	Maintain status before accessed status of external area
$\overline{\text{CS}}$		Output “H”	Output “H”
ALE		Output “L”	Output “L”

(8) BCLK output

The user can choose the BCLK output by use of bit 7 of processor mode register 0 (0004₁₆) (Note). When set to "1", the output floating.

Note: Before attempting to change the contents of the processor mode register 0, set bit 1 of the protect register (address 000A₁₆) to "1".

(9) Software wait

A software wait can be inserted by setting the wait bit (bit 7) of the processor mode register 1 (address 0005₁₆) (Note) and bits 4 to 7 of the chip select control register (address 0008₁₆).

A software wait is inserted in the internal ROM/RAM area and in the external memory area by setting the wait bit of the processor mode register 1. When set to "0", each bus cycle is executed in one BCLK cycle. When set to "1", each bus cycle is executed in two or three BCLK cycles. After the microcomputer has been reset, this bit defaults to "0". When set to "1", a wait is applied to all memory areas (two or three BCLK cycles), regardless of the contents of bits 4 to 7 of the chip select control register. Set this bit after referring to the recommended operating conditions (main clock input oscillation frequency) of the electric characteristics. However, when the user is using the $\overline{\text{RDY}}$ signal, the relevant bit in the chip select control register's bits 4 to 7 must be set to "0".

When the wait bit of the processor mode register 1 is "0", software waits can be set independently for each of the 4 areas selected using the chip select signal. Bits 4 to 7 of the chip select control register correspond to chip selects $\overline{\text{CS0}}$ to $\overline{\text{CS3}}$. When one of these bits is set to "1", the bus cycle is executed in one BCLK cycle. When set to "0", the bus cycle is executed in two or three BCLK cycles. These bits default to "0" after the microcomputer has been reset.

The SFR area is always accessed in two BCLK cycles regardless of the setting of these control bits. Also, insert a software wait if using the multiplex bus to access the external memory area.

Table 1.9.8 shows the software wait and bus cycles. Figure 1.9.6 shows example of bus timing when using software waits.

Note: Before attempting to change the contents of the processor mode register 1, set bit 1 of the protect register (address 000A₁₆) to "1".

Table 1.9.8. Software waits and bus cycles

Area	Bus status	Wait bit	Bits 4 to 7 of chip select control register	Bus cycle
SFR	———	Invalid	Invalid	2 BCLK cycles
Internal ROM/RAM	———	0	Invalid	1 BCLK cycle
	———	1	Invalid	2 BCLK cycles
External memory area	Separate bus	0	1	1 BCLK cycle
	Separate bus	0	0	2 BCLK cycles
	Separate bus	1	0 (Note)	2 BCLK cycles
	Multiplex bus	0	0	3 BCLK cycles
	Multiplex bus	1	0 (Note)	3 BCLK cycles

Note: When using the $\overline{\text{RDY}}$ signal, always set to "0".

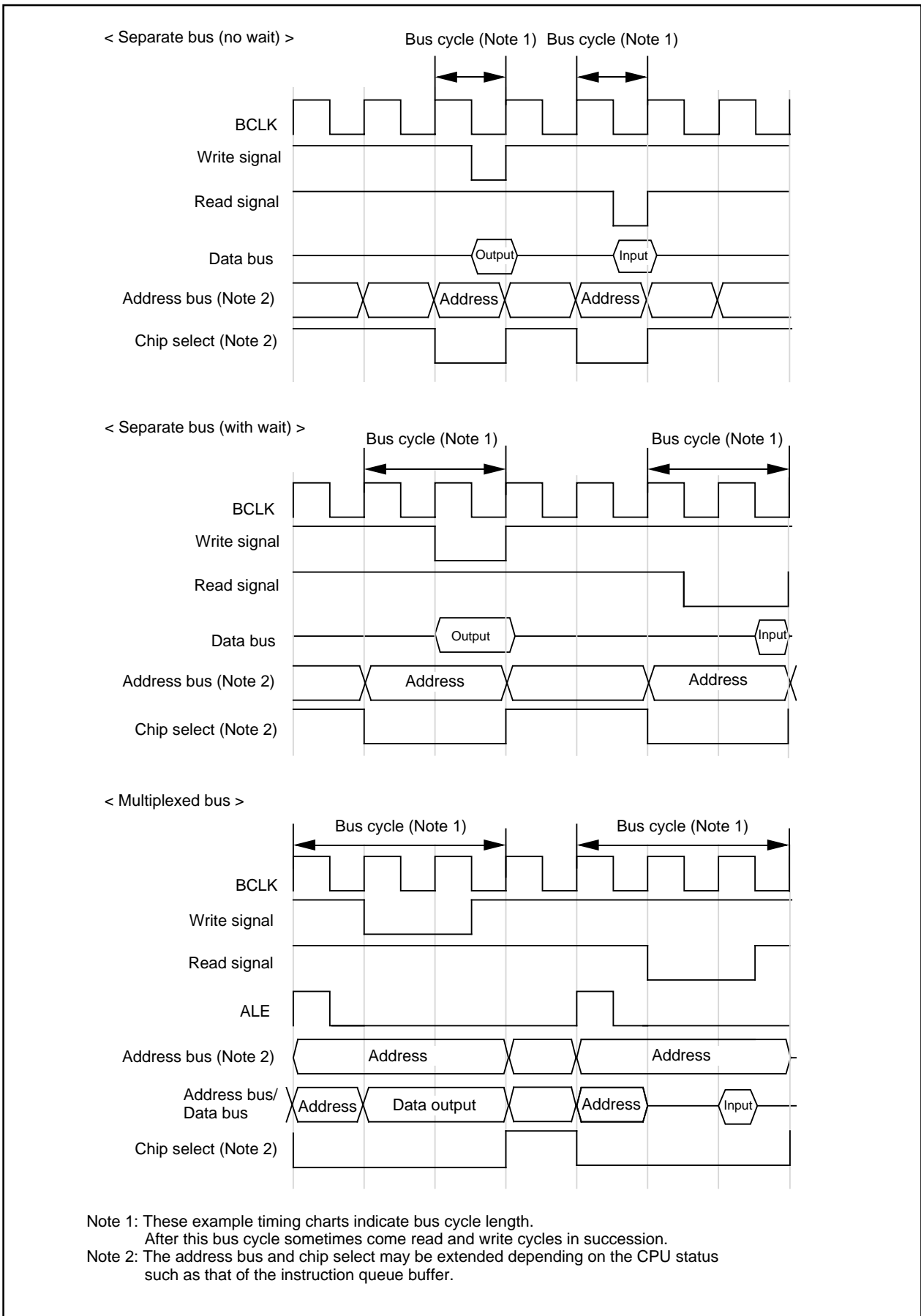

Figure 1.9.6. Typical bus timings using software wait

Clock Generating Circuit

Clock Generating Circuit

The clock generating circuit contains two oscillator circuits that supply the operating clock sources to the CPU and internal peripheral units.

Table 1.10.1. Main clock and sub-clock generating circuits

	Main clock generating circuit	Sub-clock generating circuit
Use of clock	<ul style="list-style-type: none"> • CPU's operating clock source • Internal peripheral units' operating clock source 	<ul style="list-style-type: none"> • CPU's operating clock source • Timer A/B's count clock source
Usable oscillator	Ceramic or crystal oscillator	Crystal oscillator
Pins to connect oscillator	XIN, XOUT	XCIN, XCOUT
Oscillation stop/restart function	Available	Available
Oscillator status immediately after reset	Oscillating	Stopped
Other	Externally derived clock can be input	

Example of oscillator circuit

Figure 1.10.1 shows some examples of the main clock circuit, one using an oscillator connected to the circuit, and the other one using an externally derived clock for input. Figure 1.10.2 shows some examples of sub-clock circuits, one using an oscillator connected to the circuit, and the other one using an externally derived clock for input. Circuit constants in Figures 1.10.1 and 1.10.2 vary with each oscillator used. Use the values recommended by the manufacturer of your oscillator.

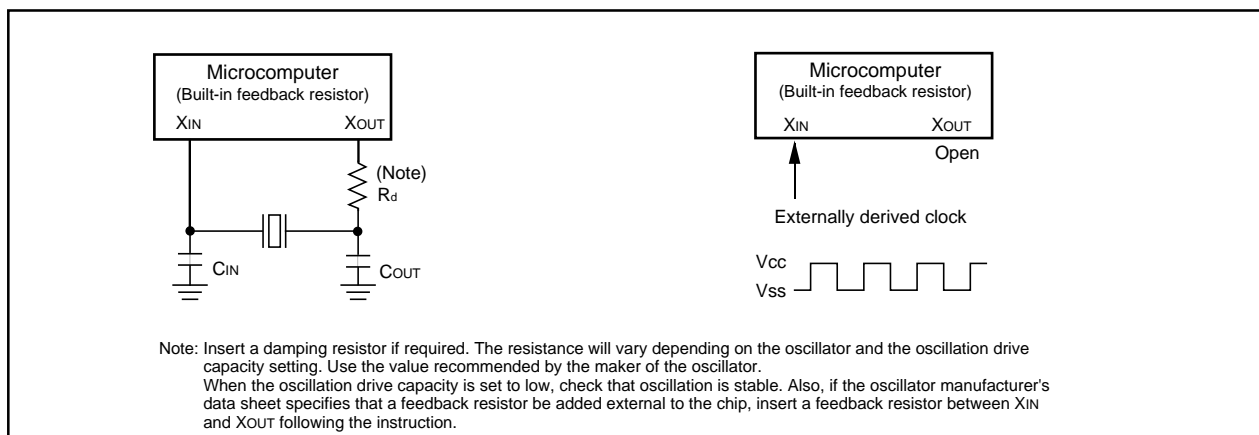

Figure 1.10.1. Examples of main clock

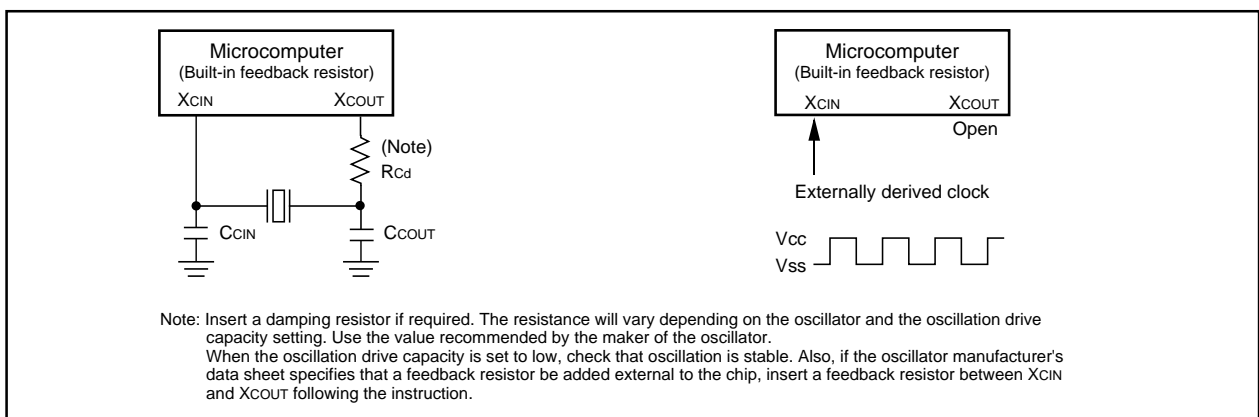

Figure 1.10.2. Examples of sub-clock

Clock Control

Figure 1.10.3 shows the block diagram of the clock generating circuit.

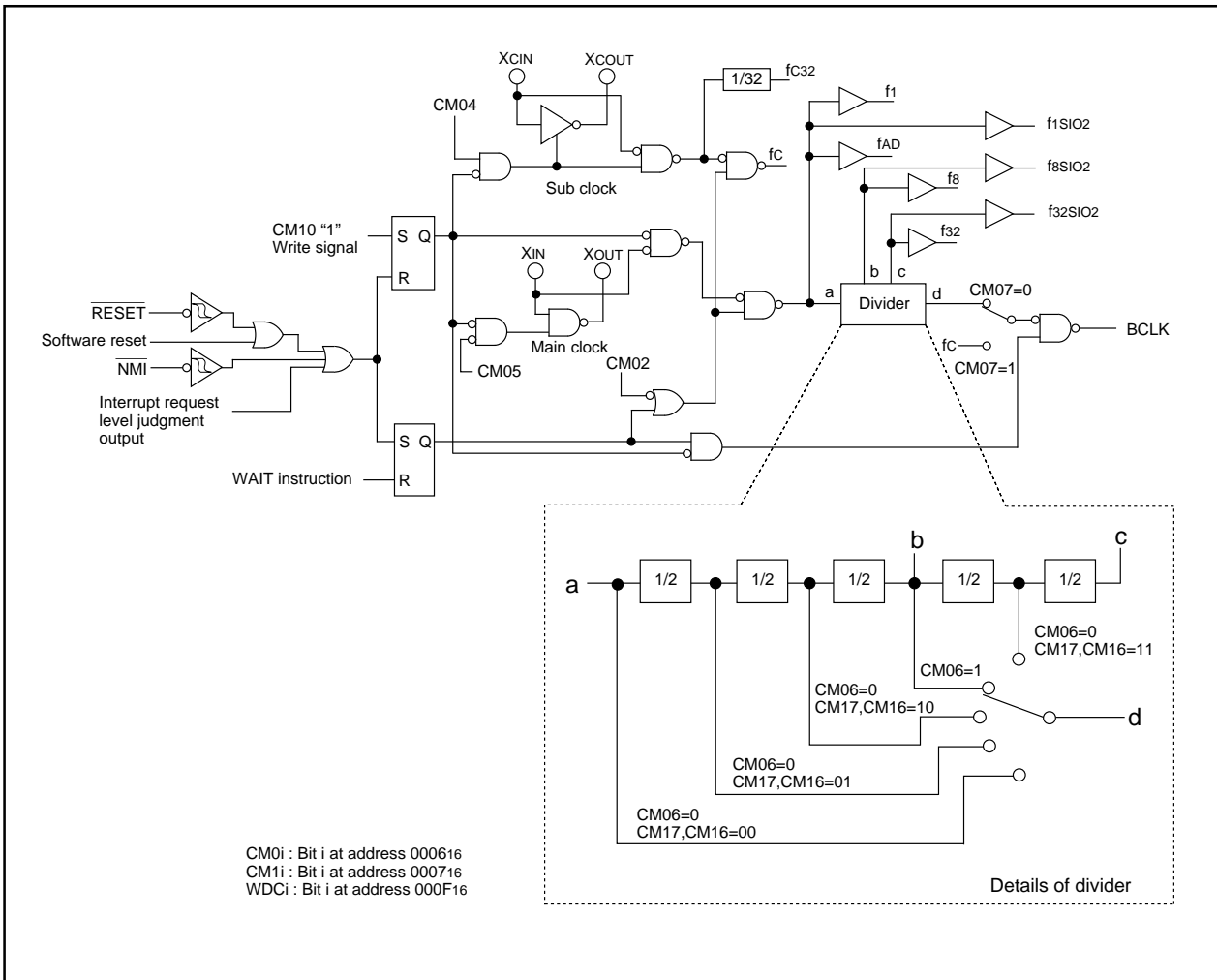

Figure 1.10.3. Clock generating circuit

The following paragraphs describes the clocks generated by the clock generating circuit.

(1) Main clock

The main clock is generated by the main clock oscillation circuit. After a reset, the clock is divided by 8 to the BCLK. The clock can be stopped using the main clock stop bit (bit 5 at address 0006₁₆). Stopping the clock, after switching the operating clock source of CPU to the sub-clock, reduces the power dissipation. After the oscillation of the main clock oscillation circuit has stabilized, the drive capacity of the main clock oscillation circuit can be reduced using the XIN-XOUT drive capacity select bit (bit 5 at address 0007₁₆). Reducing the drive capacity of the main clock oscillation circuit reduces the power dissipation. This bit changes to "1" when shifting from high-speed/medium-speed mode to stop mode, shifting to low power dissipation mode and at a reset. When shifting from high-speed/medium-speed mode to low-speed mode, the value before high-speed/medium-speed mode is retained.

(2) Sub-clock

The sub-clock is generated by the sub-clock oscillation circuit. No sub-clock is generated after a reset. After oscillation is started using the port Xc select bit (bit 4 at address 0006₁₆), the sub-clock can be selected as the BCLK by using the system clock select bit (bit 7 at address 0006₁₆). However, be sure that the sub-clock oscillation has fully stabilized before switching. After the oscillation of the sub-clock oscillation circuit has stabilized, the drive capacity of the sub-clock oscillation circuit can be reduced using the XCIN-XCOUT drive capacity select bit (bit 3 at address 0006₁₆). Reducing the drive capacity of the sub-clock oscillation circuit reduces the power dissipation. This bit changes to "1" when the port Xc select bit (bit 4 at address 0006₁₆) is set to "0", shifting to stop mode and at a reset.

When the XCIN/XCOUT is used, set ports P86 and P87 as the input ports without pull-up.

(3) BCLK

The BCLK is the clock that drives the CPU, and is fc or the clock is derived by dividing the main clock by 1, 2, 4, 8, or 16. The BCLK is derived by dividing the main clock by 8 after a reset. The BCLK signal can be output from BCLK pin by the BCLK output disable bit (bit 7 at address 0004₁₆) in the memory expansion and the microprocessor modes.

The main clock division select bit 0 (bit 6 at address 0006₁₆) changes to "1" when shifting from high-speed/medium-speed to stop mode, shifting to low power dissipation mode and at reset. When shifting from high-speed/medium-speed mode to low-speed mode, the value before high-speed/medium-speed mode is retained.

(4) Peripheral function clock(f1, f8, f32, f1SIO2, f8SIO2, f32SIO2, fAD)

The clock for the peripheral devices is derived from the main clock or by dividing it by 1, 8, or 32. The peripheral function clock is stopped by stopping the main clock or by setting the WAIT peripheral function clock stop bit (bit 2 at 0006₁₆) to "1" and then executing a WAIT instruction.

(5) fc32

This clock is derived by dividing the sub-clock by 32. It is used for the timer A and timer B counts.

(6) fc

This clock has the same frequency as the sub-clock. It is used for the BCLK and for the watchdog timer.

Figure 1.10.4 shows the system clock control registers 0 and 1.

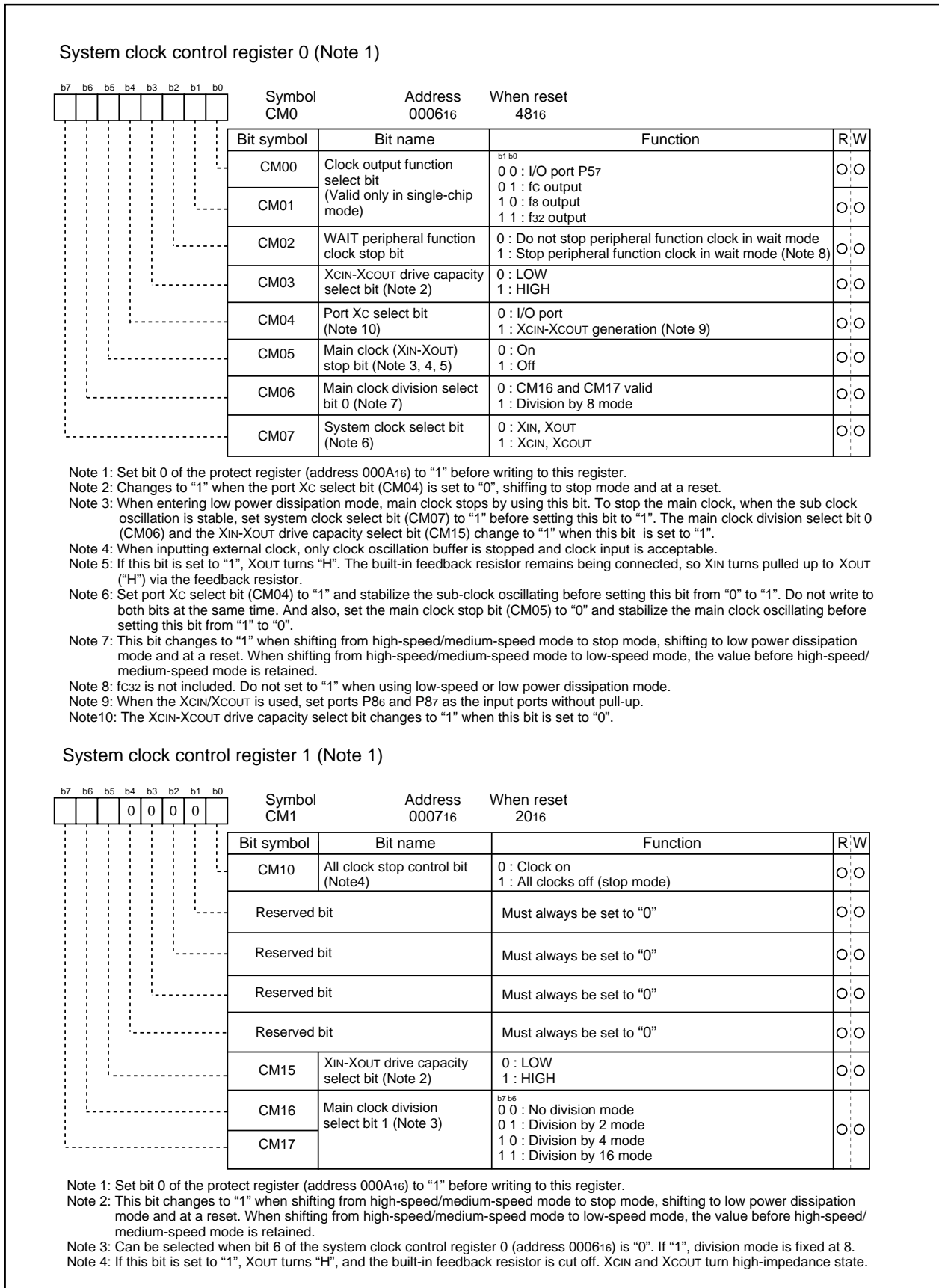

Figure 1.10.4. Clock control registers 0 and 1

Clock Generating Circuit

Clock Output

In single-chip mode, the clock output function select bits (bits 0 and 1 at address 0006₁₆) enable f₈, f₃₂, or fc to be output from the P57/CLKOUT pin. When the WAIT peripheral function clock stop bit (bit 2 at address 0006₁₆) is set to "1", the output of f₈ and f₃₂ stops when a WAIT instruction is executed.

Stop Mode

Writing "1" to the all-clock stop control bit (bit 0 at address 0007₁₆) stops all oscillation and the microcomputer enters stop mode. In stop mode, the content of the internal RAM is retained provided that VCC remains above 2V.

Because the oscillation, BCLK, f₁ to f₃₂, f₁SIO₂ to f₃₂SIO₂, fc, fc₃₂, and fAD stops in stop mode, peripheral functions such as the A-D converter and watchdog timer do not function. However, timer A and timer B operate provided that the event counter mode is set to an external pulse, and UART_i(i = 0 to 2) functions provided an external clock is selected. Table 1.10.2 shows the status of the ports in stop mode.

Stop mode is cancelled by a hardware reset or an interrupt. If an interrupt is to be used to cancel stop mode, that interrupt must first have been enabled, and the priority level of the interrupt which is not used to cancel must have been changed to 0. If returning by an interrupt, that interrupt routine is executed. If only a hardware reset or an $\overline{\text{NMI}}$ interrupt is used to cancel stop mode, change the priority level of all interrupt to 0, then shift to stop mode.

The main clock division select bit 0 (bit 6 at address 0006₁₆) changes to "1" when shifting from high-speed/medium-speed mode to stop mode, shifting to low power dissipation mode and at reset. When shifting from high-speed/medium-speed mode to low-speed mode, the value before high-speed/medium-speed mode is retained.

Table 1.10.2. Port status during stop mode

Pin		Memory expansion mode Microprocessor mode	Single-chip mode
Address bus, data bus, $\overline{\text{CS}}_0$ to $\overline{\text{CS}}_3$, $\overline{\text{BHE}}$		Retains status before stop mode	/
RD, WR, WRL, WRH		"H"	
HLDA, BCLK		"H"	
ALE		"H"	
Port		Retains status before stop mode	
CLKOUT	When fc selected	Valid only in single-chip mode	"H"
	When f ₈ , f ₃₂ selected	Valid only in single-chip mode	Retains status before stop mode

Wait Mode

When a WAIT instruction is executed, the BCLK stops and the microcomputer enters the wait mode. In this mode, oscillation continues but the BCLK and watchdog timer stop. Writing "1" to the WAIT peripheral function clock stop bit and executing a WAIT instruction stops the clock being supplied to the internal peripheral functions, allowing power dissipation to be reduced. However, peripheral function clock fc32 does not stop so that the peripherals using fc32 do not contribute to the power saving. When the MCU running in low-speed or low power dissipation mode, do not enter WAIT mode with this bit set to "1". Table 1.10.3 shows the status of the ports in wait mode.

Wait mode is cancelled by a hardware reset or an interrupt. If an interrupt is used to cancel wait mode, that interrupt must first have been enabled, and the priority level of the interrupt which is not used to cancel must have been changed to 0. If returning by an interrupt, the clock in which the WAIT instruction executed is set to BCLK by the microcomputer, and the action is resumed from the interrupt routine. If only a hardware reset or an $\overline{\text{NMI}}$ interrupt is used to cancel wait mode, change the priority level of all interrupt to 0, then shift to wait mode.

Table 1.10.3. Port status during wait mode

Pin		Memory expansion mode Microprocessor mode	Single-chip mode
Address bus, data bus, $\overline{\text{CS0}}$ to $\overline{\text{CS3}}$, $\overline{\text{BHE}}$		Retains status before wait mode	/
RD, WR, $\overline{\text{WRL}}$, $\overline{\text{WRH}}$		"H"	
HLDA, BCLK		"H"	
ALE		"H"	
Port		Retains status before wait mode	
CLKOUT	When fc selected	Valid only in single-chip mode	Does not stop
	When f8, f32 selected	Valid only in single-chip mode	Does not stop when the WAIT peripheral function clock stop bit is "0". When the WAIT peripheral function clock stop bit is "1", the status immediately prior to entering wait mode is maintained.

Status Transition of BCLK

Status Transition of BCLK

Power dissipation can be reduced and low-voltage operation achieved by changing the count source for BCLK. Table 1.10.4 shows the operating modes corresponding to the settings of system clock control registers 0 and 1.

When reset, the device starts in division by 8 mode. The main clock division select bit 0 (bit 6 at address 0006₁₆) and the XIN-XOUT drive capacity select bit (bit 5 at address 0007₁₆) change to “1” when shifting from high-speed/medium-speed mode to stop mode, shifting to low power dissipation mode and at a reset. When shifting from high-speed/medium-speed mode to low-speed mode, the value before high-speed/medium-speed mode is retained. The following shows the operational modes of BCLK.

(1) Division by 2 mode

The main clock is divided by 2 to obtain the BCLK.

(2) Division by 4 mode

The main clock is divided by 4 to obtain the BCLK.

(3) Division by 8 mode

The main clock is divided by 8 to obtain the BCLK. When reset, the device starts operating from this mode. Before the user can go from this mode to no division mode, division by 2 mode, or division by 4 mode, the main clock must be oscillating stably. When going to low-speed or lower power consumption mode, make sure the sub-clock is oscillating stably.

(4) Division by 16 mode

The main clock is divided by 16 to obtain the BCLK.

(5) No-division mode

The main clock is divided by 1 to obtain the BCLK.

(6) Low-speed mode

fc is used as the BCLK. Note that oscillation of both the main and sub-clocks must have stabilized before transferring from this mode to another or vice versa. At least 2 to 3 seconds are required after the sub-clock starts. Therefore, the program must be written to wait until this clock has stabilized immediately after powering up and after stop mode is cancelled.

(7) Low power dissipation mode

fc is the BCLK and the main clock is stopped.

Note : Before the count source for BCLK can be changed from XIN to XCIN or vice versa, the clock to which the count source is going to be switched must be oscillating stably. Allow a wait time in software for the oscillation to stabilize before switching over the clock.

Table 1.10.4. Operating modes dictated by settings of system clock control registers 0 and 1

CM17	CM16	CM07	CM06	CM05	CM04	Operating mode of BCLK
0	1	0	0	0	Invalid	Division by 2 mode
1	0	0	0	0	Invalid	Division by 4 mode
Invalid	Invalid	0	1	0	Invalid	Division by 8 mode
1	1	0	0	0	Invalid	Division by 16 mode
0	0	0	0	0	Invalid	No-division mode
Invalid	Invalid	1	Invalid	0	1	Low-speed mode
Invalid	Invalid	1	Invalid	1	1	Low power dissipation mode

CM1i : Bit i of the address 0007₁₆

CM0i : Bit i of the address 0006₁₆

Power control

The following is a description of the three available power control modes:

Modes

Power control is available in three modes.

(a) Normal operation mode

- **High-speed mode**

Divide-by-1 frequency of the main clock becomes the BCLK. The CPU operates with the BCLK. Each peripheral function operates according to its assigned clock.

- **Medium-speed mode**

Divide-by-2, divide-by-4, divide-by-8, or divide-by-16 frequency of the main clock becomes the BCLK. The CPU operates with the BCLK. Each peripheral function operates according to its assigned clock.

- **Low-speed mode**

fc becomes the BCLK. The CPU operates according to the fc clock. The fc clock is supplied by the subclock. Each peripheral function operates according to its assigned clock.

- **Low power dissipation mode**

The main clock operating in low-speed mode is stopped. The CPU operates according to the fc clock. The fc clock is supplied by the subclock. The only peripheral functions that operate are those with the subclock selected as the count source.

(b) Wait mode

The CPU operation is stopped. The oscillators do not stop.

(c) Stop mode

All oscillators stop. The CPU and all built-in peripheral functions stop. This mode, among the three modes listed here, is the most effective in decreasing power consumption.

Figure 1.10.5 is the state transition diagram of the above modes.



Figure 1.10.5. State transition diagram of Power control mode

Protection

Protection

The protection function is provided so that the values in important registers cannot be changed in the event that the program runs out of control. Figure 1.10.6 shows the protect register. The values in the processor mode register 0 (address 0004₁₆), processor mode register 1 (address 0005₁₆), system clock control register 0 (address 0006₁₆), system clock control register 1 (address 0007₁₆), port P9 direction register (address 03F3₁₆) can only be changed when the respective bit in the protect register is set to "1". Therefore, important outputs can be allocated to port P9.

If, after "1" (write-enabled) has been written to the port P9 direction register write-enable bit (bit 2 at address 000A₁₆), a value is written to any address, the bit automatically reverts to "0" (write-inhibited). However, the system clock control registers 0 and 1 write-enable bit (bit 0 at 000A₁₆) and processor mode register 0 and 1 write-enable bit (bit 1 at 000A₁₆) do not automatically return to "0" after a value has been written to an address. The program must therefore be written to return these bits to "0".

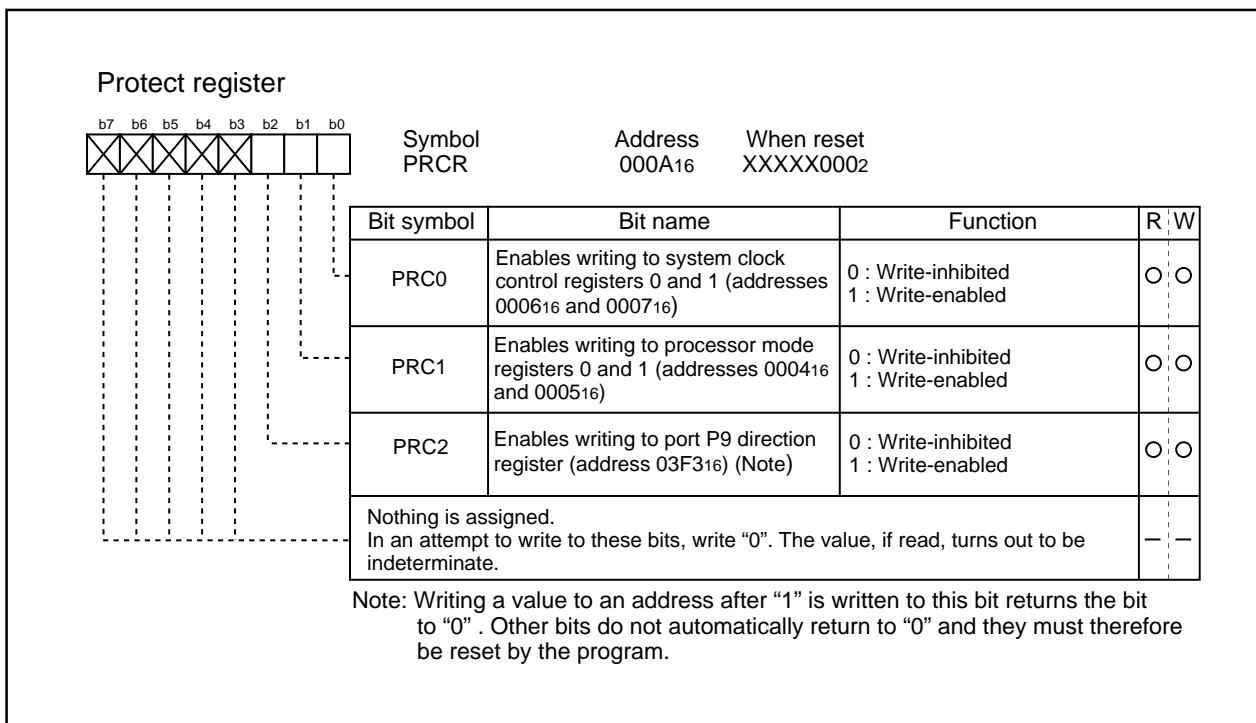

Figure 1.10.6. Protect register

Overview of Interrupt

Type of Interrupts

Figure 1.11.1 lists the types of interrupts.

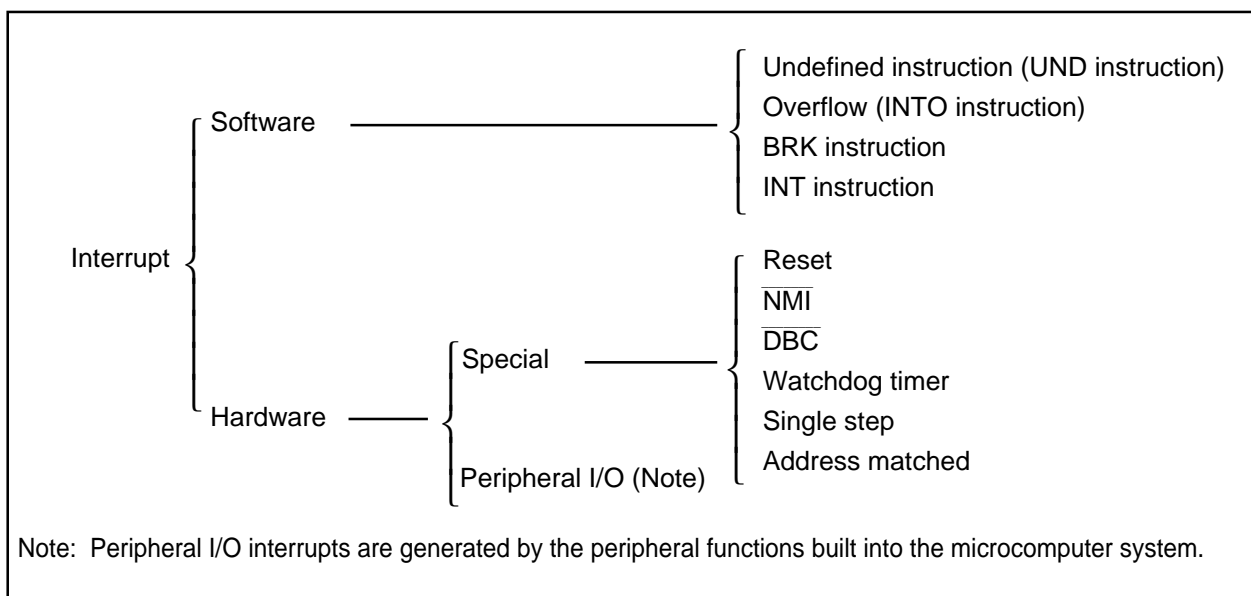

Figure 1.11.1. Classification of interrupts

- Maskable interrupt : An interrupt which can be enabled (disabled) by the interrupt enable flag (I flag) or whose interrupt priority **can be changed** by priority level.
- Non-maskable interrupt : An interrupt which cannot be enabled (disabled) by the interrupt enable flag (I flag) or whose interrupt priority **cannot be changed** by priority level.

Software Interrupts

A software interrupt occurs when executing certain instructions. Software interrupts are non-maskable interrupts.

- **Undefined instruction interrupt**

An undefined instruction interrupt occurs when executing the UND instruction.

- **Overflow interrupt**

An overflow interrupt occurs when executing the INTO instruction with the overflow flag (O flag) set to "1". The following are instructions whose O flag changes by arithmetic:

ABS, ADC, ADCF, ADD, CMP, DIV, DIVU, DIVX, NEG, RMPA, SBB, SHA, SUB

- **BRK interrupt**

A BRK interrupt occurs when executing the BRK instruction.

- **INT interrupt**

An INT interrupt occurs when specifying one of software interrupt numbers 0 through 63 and executing the INT instruction. Software interrupt numbers 0 through 31 are assigned to peripheral I/O interrupts, so executing the INT instruction allows executing the same interrupt routine that a peripheral I/O interrupt does.

The stack pointer (SP) used for the INT interrupt is dependent on which software interrupt number is involved.

So far as software interrupt numbers 0 through 31 are concerned, the microcomputer saves the stack pointer assignment flag (U flag) when it accepts an interrupt request. If change the U flag to "0" and select the interrupt stack pointer (ISP), and then execute an interrupt sequence. When returning from the interrupt routine, the U flag is returned to the state it was before the acceptance of interrupt request. So far as software numbers 32 through 63 are concerned, the stack pointer does not make a shift.

Hardware Interrupts

Hardware interrupts are classified into two types — special interrupts and peripheral I/O interrupts.

(1) Special interrupts

Special interrupts are non-maskable interrupts.

- **Reset**

Reset occurs if an “L” is input to the $\overline{\text{RESET}}$ pin.

- **$\overline{\text{NMI}}$ interrupt**

An $\overline{\text{NMI}}$ interrupt occurs if an “L” is input to the $\overline{\text{NMI}}$ pin.

- **$\overline{\text{DBC}}$ interrupt**

This interrupt is exclusively for the debugger, do not use it in other circumstances.

- **Watchdog timer interrupt**

Generated by the watchdog timer. Write to the watchdog timer start register after the watchdog timer interrupt occurs (initialize watchdog timer).

- **Single-step interrupt**

This interrupt is exclusively for the debugger, do not use it in other circumstances. With the debug flag (D flag) set to “1”, a single-step interrupt occurs after one instruction is executed.

- **Address match interrupt**

An address match interrupt occurs immediately before the instruction held in the address indicated by the address match interrupt register is executed with the address match interrupt enable bit set to “1”. If an address other than the first address of the instruction in the address match interrupt register is set, no address match interrupt occurs.

(2) Peripheral I/O interrupts

A peripheral I/O interrupt is generated by one of built-in peripheral functions. Built-in peripheral functions are dependent on classes of products, so the interrupt factors too are dependent on classes of products. The interrupt vector table is the same as the one for software interrupt numbers 0 through 31 the INT instruction uses. Peripheral I/O interrupts are maskable interrupts.

- **Bus collision detection interrupt**

This is an interrupt that the serial I/O bus collision detection generates.

- **DMA0 interrupt**

This is an interrupts that DMA generates.

- **Key-input interrupt**

A key-input interrupt occurs if an “L” is input to the $\overline{\text{KI}}$ pin.

- **A-D conversion interrupt**

This is an interrupt that the A-D converter generates.

- **UART0, UART1, UART2/NACK transmission interrupt**

These are interrupts that the serial I/O transmission generates.

- **UART0, UART1, UART2/ACK reception interrupt**

These are interrupts that the serial I/O reception generates.

- **Timer A0 interrupt through timer A2 interrupt**

These are interrupts that timer A generates

- **Timer B1, timer B2 interrupt**

These are interrupts that timer B generates.

- **$\overline{\text{INT0}}$ interrupt through $\overline{\text{INT2}}$ interrupt**

An $\overline{\text{INT}}$ interrupt occurs if either a rising edge or a falling edge or a both edge is input to the $\overline{\text{INT}}$ pin.

Interrupts and Interrupt Vector Tables

If an interrupt request is accepted, a program branches to the interrupt routine set in the interrupt vector table. Set the first address of the interrupt routine in each vector table. Figure 1.11.2 shows the format for specifying the address.

Two types of interrupt vector tables are available — fixed vector table in which addresses are fixed and variable vector table in which addresses can be varied by the setting.

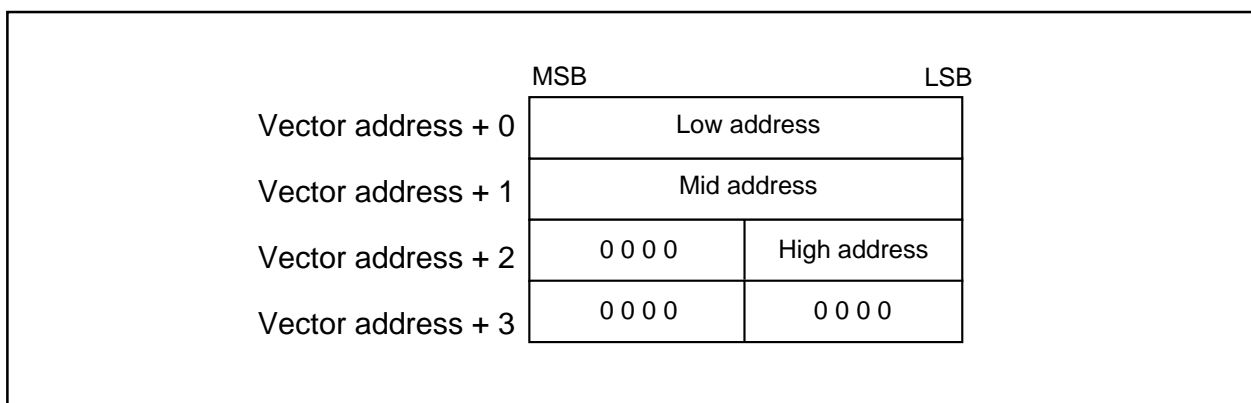

Figure 1.11.2. Format for specifying interrupt vector addresses

• **Fixed vector tables**

The fixed vector table is a table in which addresses are fixed. The vector tables are located in an area extending from FFFDC₁₆ to FFFFF₁₆. One vector table comprises four bytes. Set the first address of interrupt routine in each vector table. Table 1.11.1 shows the interrupts assigned to the fixed vector tables and addresses of vector tables.

Table 1.11.1. Interrupts assigned to the fixed vector tables and addresses of vector tables

Interrupt source	Vector table addresses Address (L) to address (H)	Remarks
Undefined instruction	FFFD _{C16} to FFFD _{F16}	Interrupt on UND instruction
Overflow	FFFE ₀₁₆ to FFFE ₃₁₆	Interrupt on INTO instruction
BRK instruction	FFFE ₄₁₆ to FFFE ₇₁₆	If the vector contains FF ₁₆ , program execution starts from the address shown by the vector in the variable vector table
Address match	FFFE ₈₁₆ to FFFE _{B16}	There is an address-matching interrupt enable bit
Single step (Note)	FFFE _{C16} to FFFE _{F16}	Do not use
Watchdog timer	FFFF ₀₁₆ to FFFF ₃₁₆	
DBC (Note)	FFFF ₄₁₆ to FFFF ₇₁₆	Do not use
NMI	FFFF ₈₁₆ to FFFF _{B16}	External interrupt by input to $\overline{\text{NMI}}$ pin
Reset	FFFF _{C16} to FFFF _{F16}	

Note: Interrupts used for debugging purposes only.

- **Variable vector tables**

The addresses in the variable vector table can be modified, according to the user's settings. Indicate the first address using the interrupt table register (INTB). The 256-byte area subsequent to the address the INTB indicates becomes the area for the variable vector tables. One vector table comprises four bytes. Set the first address of the interrupt routine in each vector table. Table 1.11.2 shows the interrupts assigned to the variable vector tables and addresses of vector tables.

Table 1.11.2. Interrupts assigned to the variable vector tables and addresses of vector tables

Software interrupt number	Vector table address Address (L) to address (H)	Interrupt source	Remarks
Software interrupt number 0	+0 to +3 (Note 1)	BRK instruction	Cannot be masked I flag
Software interrupt number 10	+40 to +43 (Note 1)	Bus collision detection	
Software interrupt number 11	+44 to +47 (Note 1)	DMA0	
Software interrupt number 13	+52 to +55 (Note 1)	Key input interrupt	
Software interrupt number 14	+56 to +59 (Note 1)	A-D	
Software interrupt number 15	+60 to +63 (Note 1)	UART2 transmit/NACK (Note 2)	
Software interrupt number 16	+64 to +67 (Note 1)	UART2 receive/ACK (Note 2)	
Software interrupt number 17	+68 to +71 (Note 1)	UART0 transmit	
Software interrupt number 18	+72 to +75 (Note 1)	UART0 receive	
Software interrupt number 19	+76 to +79 (Note 1)	UART1 transmit	
Software interrupt number 20	+80 to +83 (Note 1)	UART1 receive	
Software interrupt number 21	+84 to +87 (Note 1)	Timer A0	
Software interrupt number 22	+88 to +91 (Note 1)	Timer A1	
Software interrupt number 23	+92 to +95 (Note 1)	Timer A2	
Software interrupt number 27	+108 to +111 (Note 1)	Timer B1	
Software interrupt number 28	+112 to +115 (Note 1)	Timer B2	
Software interrupt number 29	+116 to +119 (Note 1)	$\overline{\text{INT0}}$	
Software interrupt number 30	+120 to +123 (Note 1)	$\overline{\text{INT1}}$	
Software interrupt number 31	+124 to +127 (Note 1)	$\overline{\text{INT2}}$	
Software interrupt number 32 to Software interrupt number 63	+128 to +131 (Note 1) to +252 to +255 (Note 1)	Software interrupt	Cannot be masked I flag

Note 1: Address relative to address in interrupt table register (INTB).

Note 2: When IIC mode is selected, NACK and ACK interrupts are selected.

Interrupt Control

Descriptions are given here regarding how to enable or disable maskable interrupts and how to set the priority to be accepted. What is described here does not apply to non-maskable interrupts.

Enable or disable a maskable interrupt using the interrupt enable flag (I flag), interrupt priority level selection bit, or processor interrupt priority level (IPL). Whether an interrupt request is present or absent is indicated by the interrupt request bit. The interrupt request bit and the interrupt priority level selection bit are located in the interrupt control register of each interrupt. Also, the interrupt enable flag (I flag) and the IPL are located in the flag register (FLG).

Figure 1.11.3 shows the memory map of the interrupt control registers.

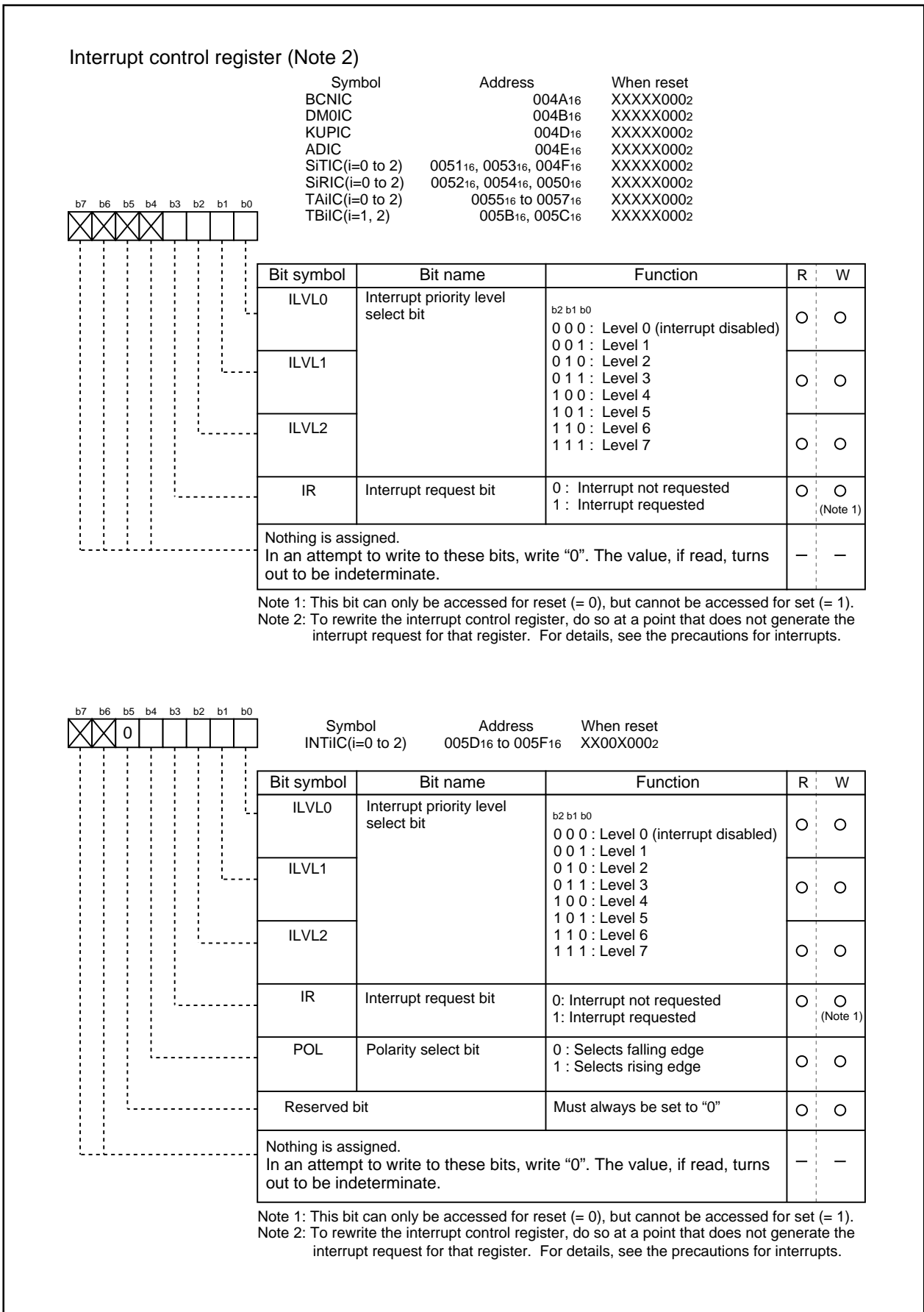

Figure 1.11.3. Interrupt control registers

Interrupt Enable Flag (I flag)

The interrupt enable flag (I flag) controls the enabling and disabling of maskable interrupts. Setting this flag to “1” enables all maskable interrupts; setting it to “0” disables all maskable interrupts. This flag is set to “0” after reset.

Interrupt Request Bit

The interrupt request bit is set to “1” by hardware when an interrupt is requested. After the interrupt is accepted and jumps to the corresponding interrupt vector, the request bit is set to “0” by hardware. The interrupt request bit can also be set to “0” by software. (Do not set this bit to “1”).

Interrupt Priority Level Select Bit and Processor Interrupt Priority Level (IPL)

Set the interrupt priority level using the interrupt priority level select bit, which is one of the component bits of the interrupt control register. When an interrupt request occurs, the interrupt priority level is compared with the IPL. The interrupt is enabled only when the priority level of the interrupt is higher than the IPL. Therefore, setting the interrupt priority level to “0” disables the interrupt.

Table 1.11.3 shows the settings of interrupt priority levels and Table 1.11.4 shows the interrupt levels enabled, according to the contents of the IPL.

The following are conditions under which an interrupt is accepted:

- interrupt enable flag (I flag) = “1”
- interrupt request bit = “1”
- interrupt priority level > IPL

The interrupt enable flag (I flag), the interrupt request bit, the interrupt priority select bit, and the IPL are independent, and they are not affected by one another.

Table 1.11.3. Settings of interrupt priority levels

Interrupt priority level select bit	Interrupt priority level	Priority order
b2 b1 b0 0 0 0	Level 0 (interrupt disabled)	————
0 0 1	Level 1	Low ↓ High
0 1 0	Level 2	
0 1 1	Level 3	
1 0 0	Level 4	
1 0 1	Level 5	
1 1 0	Level 6	
1 1 1	Level 7	

Table 1.11.4. Interrupt levels enabled according to the contents of the IPL

IPL	Enabled interrupt priority levels
IPL ₂ IPL ₁ IPL ₀ 0 0 0	Interrupt levels 1 and above are enabled
0 0 1	Interrupt levels 2 and above are enabled
0 1 0	Interrupt levels 3 and above are enabled
0 1 1	Interrupt levels 4 and above are enabled
1 0 0	Interrupt levels 5 and above are enabled
1 0 1	Interrupt levels 6 and above are enabled
1 1 0	Interrupt levels 7 and above are enabled
1 1 1	All maskable interrupts are disabled

Rewrite the interrupt control register

To rewrite the interrupt control register, do so at a point that does not generate the interrupt request for that register. If there is possibility of the interrupt request occur, rewrite the interrupt control register after the interrupt is disabled. The program examples are described as follow:

Example 1:

```
INT_SWITCH1:
  FCLR  I           ; Disable interrupts.
  AND.B #00h, 0055h ; Clear TA0IC int. priority level and int. request bit.
  NOP                    ; Four NOP instructions are required when using HOLD function.
  NOP
  FSET  I           ; Enable interrupts.
```

Example 2:

```
INT_SWITCH2:
  FCLR  I           ; Disable interrupts.
  AND.B #00h, 0055h ; Clear TA0IC int. priority level and int. request bit.
  MOV.W MEM, R0     ; Dummy read.
  FSET  I           ; Enable interrupts.
```

Example 3:

```
INT_SWITCH3:
  PUSHC FLG         ; Push Flag register onto stack
  FCLR  I           ; Disable interrupts.
  AND.B #00h, 0055h ; Clear TA0IC int. priority level and int. request bit.
  POPC  FLG         ; Enable interrupts.
```

The reason why two NOP instructions (four when using the HOLD function) or dummy read are inserted before FSET I in Examples 1 and 2 is to prevent the interrupt enable flag I from being set before the interrupt control register is rewritten due to effects of the instruction queue.

When changing an interrupt control register in a state of interrupts being disabled, please read the following precautions on instructions used before changing the register.

Changing a non-interrupt request bit

If an interrupt request for an interrupt control register is generated during an instruction to rewrite the register is being executed, there is a case that the interrupt request bit is not set and consequently the interrupt is ignored. This will depend on the instruction. If this creates problems, use the below instructions to change the register.

Instructions : AND, OR, BCLR, BSET

Changing the interrupt request bit

When attempting to clear the interrupt request bit of an interrupt control register, the interrupt request bit is not cleared sometimes. This will depend on the instruction. If this creates problems, use the below instructions to change the register.

Instructions : MOV

Interrupt Sequence

An interrupt sequence — what are performed over a period from the instant an interrupt is accepted to the instant the interrupt routine is executed — is described here.

If an interrupt occurs during execution of an instruction, the processor determines its priority when the execution of the instruction is completed, and transfers control to the interrupt sequence from the next cycle. If an interrupt occurs during execution of either the SMOVB, SMOVF, SSTR or RMPA instruction, the processor temporarily suspends the instruction being executed, and transfers control to the interrupt sequence.

In the interrupt sequence, the processor carries out the following in sequence given:

- (1) CPU gets the interrupt information (the interrupt number and interrupt request level) by reading address 00000₁₆. After this, the corresponding interrupt request bit becomes “0”.
- (2) Saves the content of the flag register (FLG) as it was immediately before the start of interrupt sequence in the temporary register (Note) within the CPU.
- (3) Sets the interrupt enable flag (I flag), the debug flag (D flag), and the stack pointer select flag (U flag) to “0” (the U flag, however does not change if the INT instruction, in software interrupt numbers 32 through 63, is executed)
- (4) Saves the content of the temporary register (Note) within the CPU in the stack area.
- (5) Saves the content of the program counter (PC) in the stack area.
- (6) Sets the interrupt priority level of the accepted instruction in the IPL.

After the interrupt sequence is completed, the processor resumes executing instructions from the first address of the interrupt routine.

Note: This register cannot be utilized by the user.

Interrupt Response Time

'Interrupt response time' is the period between the instant an interrupt occurs and the instant the first instruction within the interrupt routine has been executed. This time comprises the period from the occurrence of an interrupt to the completion of the instruction under execution at that moment (a) and the time required for executing the interrupt sequence (b). Figure 1.11.4 shows the interrupt response time.

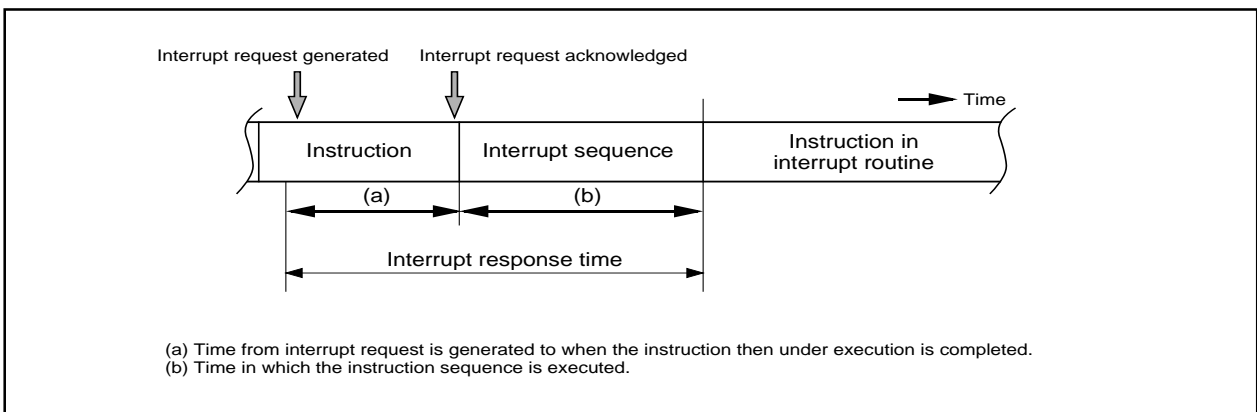

Figure 1.11.4. Interrupt response time

Time (a) is dependent on the instruction under execution. Thirty cycles is the maximum required for the DIVX instruction (without wait).

Time (b) is as shown in Table 1.11.5.

Table 1.11.5. Time required for executing the interrupt sequence

Interrupt vector address	Stack pointer (SP) value	16-Bit bus, without wait	8-Bit bus, without wait
Even	Even	18 cycles (Note 1)	20 cycles (Note 1)
Even	Odd	19 cycles (Note 1)	20 cycles (Note 1)
Odd (Note 2)	Even	19 cycles (Note 1)	20 cycles (Note 1)
Odd (Note 2)	Odd	20 cycles (Note 1)	20 cycles (Note 1)

Note 1: Add 2 cycles in the case of a DBC interrupt; add 1 cycle in the case either of an address match interrupt or of a single-step interrupt.

Note 2: Locate an interrupt vector address in an even address, if possible.

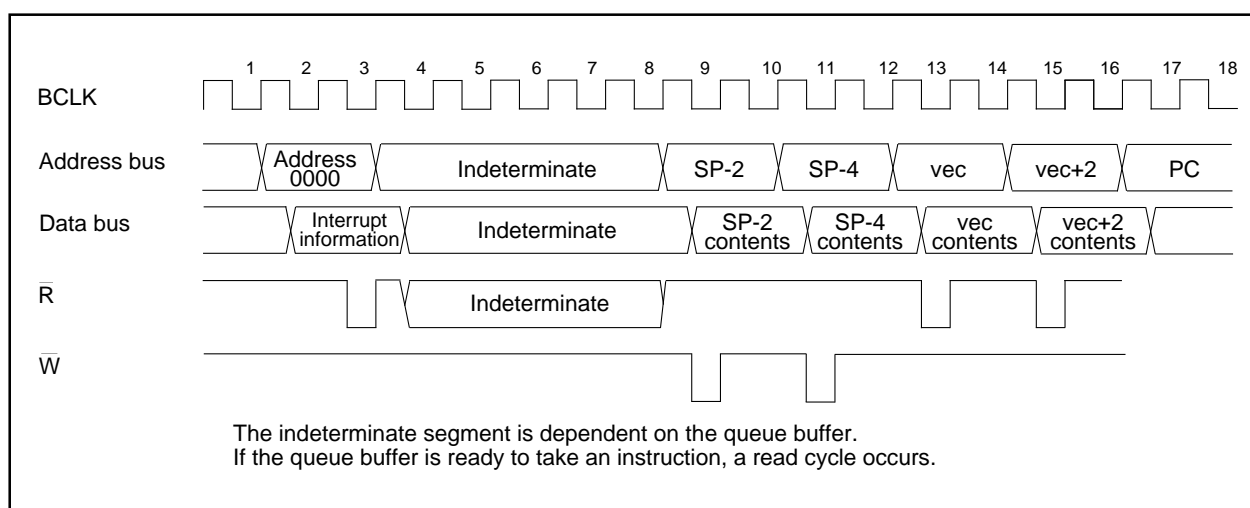

Figure 1.11.5. Time required for executing the interrupt sequence

Variation of IPL when Interrupt Request is Accepted

If an interrupt request is accepted, the interrupt priority level of the accepted interrupt is set in the IPL.

If an interrupt request, that does not have an interrupt priority level, is accepted, one of the values shown in Table 1.11.6 is set in the IPL.

Table 1.11.6. Relationship between interrupts without interrupt priority levels and IPL

Interrupt sources without priority levels	Value set in the IPL
Watchdog timer, NMI	7
Reset	0
Other	Not changed

Saving Registers

In the interrupt sequence, only the contents of the flag register (FLG) and that of the program counter (PC) are saved in the stack area.

First, the processor saves the four higher-order bits of the program counter, and 4 upper-order bits and 8 lower-order bits of the FLG register, 16 bits in total, in the stack area, then saves 16 lower-order bits of the program counter. Figure 1.11.6 shows the state of the stack as it was before the acceptance of the interrupt request, and the state the stack after the acceptance of the interrupt request.

Save other necessary registers at the beginning of the interrupt routine using software. Using the PUSHM instruction alone can save all the registers except the stack pointer (SP).

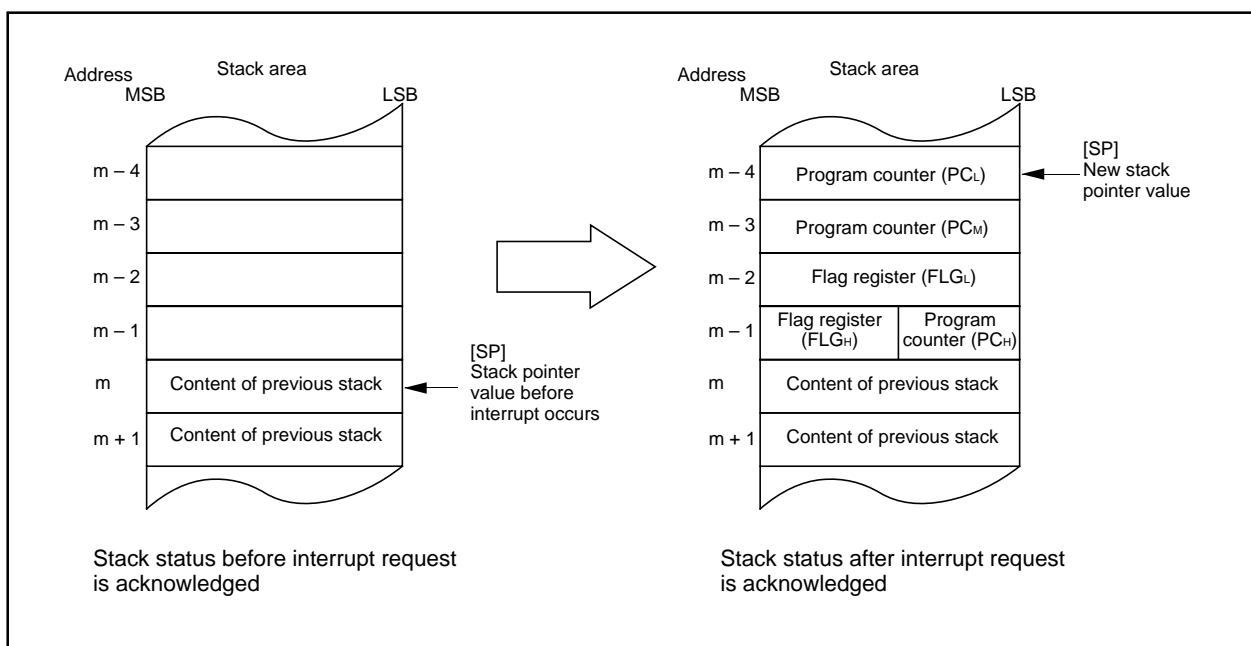

Figure 1.11.6. State of stack before and after acceptance of interrupt request

The operation of saving registers carried out in the interrupt sequence is dependent on whether the content of the stack pointer (Note) , at the time of acceptance of an interrupt request, is even or odd. If the content of the stack pointer (Note) is even, the content of the flag register (FLG) and the content of the program counter (PC) are saved, 16 bits at a time. If odd, their contents are saved in two steps, 8 bits at a time. Figure 1.11.7 shows the operation of the saving registers.

Note: When any INT instruction in software numbers 32 to 63 has been executed, this is the stack pointer indicated by the U flag. Otherwise, it is the interrupt stack pointer (ISP).

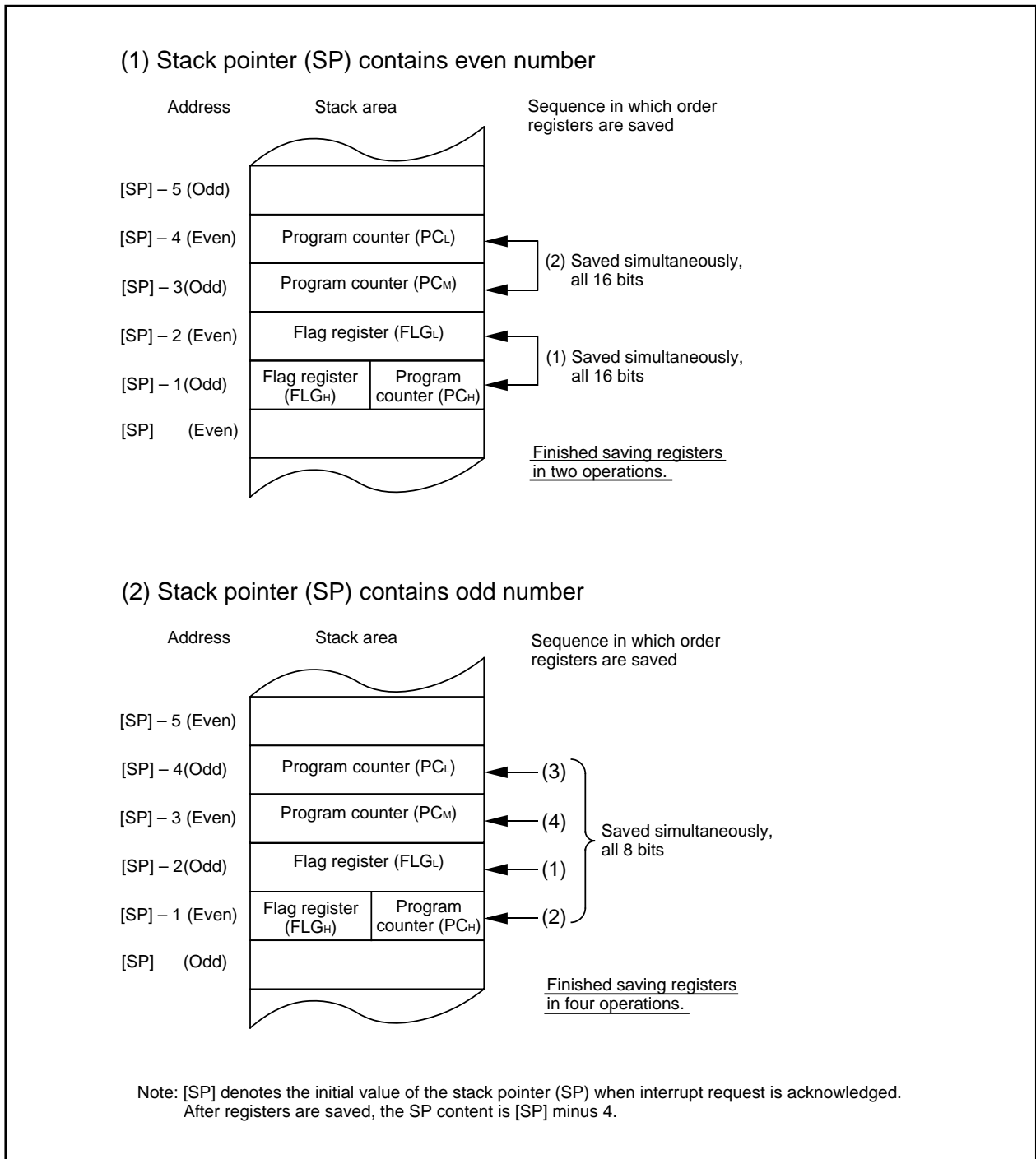

Figure 1.11.7. Operation of saving registers

Returning from an Interrupt Routine

Executing the REIT instruction at the end of an interrupt routine returns the contents of the flag register (FLG) as it was immediately before the start of interrupt sequence and the contents of the program counter (PC), both of which have been saved in the stack area. Then control returns to the program that was being executed before the acceptance of the interrupt request, so that the suspended process resumes. Return the other registers saved by software within the interrupt routine using the POPM or similar instruction before executing the REIT instruction.

Interrupt Priority

If there are two or more interrupt requests occurring at a point in time within a single sampling (checking whether interrupt requests are made), the interrupt assigned a higher priority is accepted.

Assign an arbitrary priority to maskable interrupts (peripheral I/O interrupts) using the interrupt priority level select bit. If the same interrupt priority level is assigned, however, the interrupt assigned a higher hardware priority is accepted.

Priorities of the special interrupts, such as Reset (dealt with as an interrupt assigned the highest priority), watchdog timer interrupt, etc. are regulated by hardware.

Figure 1.11.8 shows the priorities of hardware interrupts.

Software interrupts are not affected by the interrupt priority. If an instruction is executed, control branches invariably to the interrupt routine.

Reset > $\overline{\text{NMI}}$ > $\overline{\text{DBC}}$ > Watchdog timer > Peripheral I/O > Single step > Address match

Figure 1.11.8. Hardware interrupts priorities

Interrupt resolution circuit

When two or more interrupts are generated simultaneously, this circuit selects the interrupt with the highest priority level. Figure 1.11.9 shows the circuit that judges the interrupt priority level.

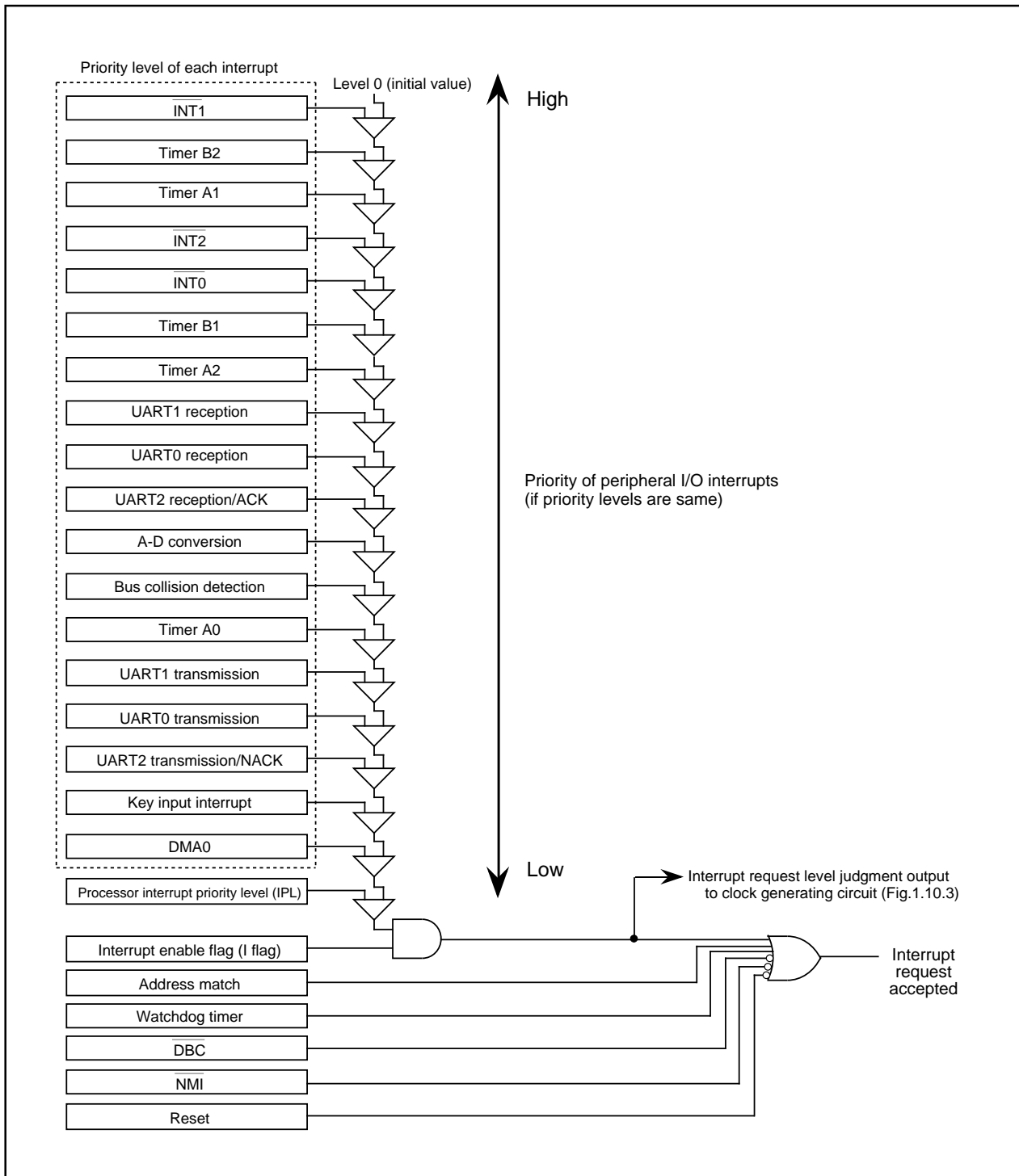

Figure 1.11.9. Maskable interrupts priorities (peripheral I/O interrupts)

INT Interrupt**INT Interrupt**

INT0 to INT2 are triggered by the edges of external inputs. The edge polarity is selected using the polarity select bit.

As for external interrupt input, an interrupt can be generated both at the rising edge and at the falling edge by setting "1" in the INTi interrupt polarity switching bit of the interrupt request cause select register (035F₁₆). To select both edges, set the polarity switching bit of the corresponding interrupt control register to 'falling edge' ("0").

Figure 1.11.10 shows the Interrupt request cause select register.

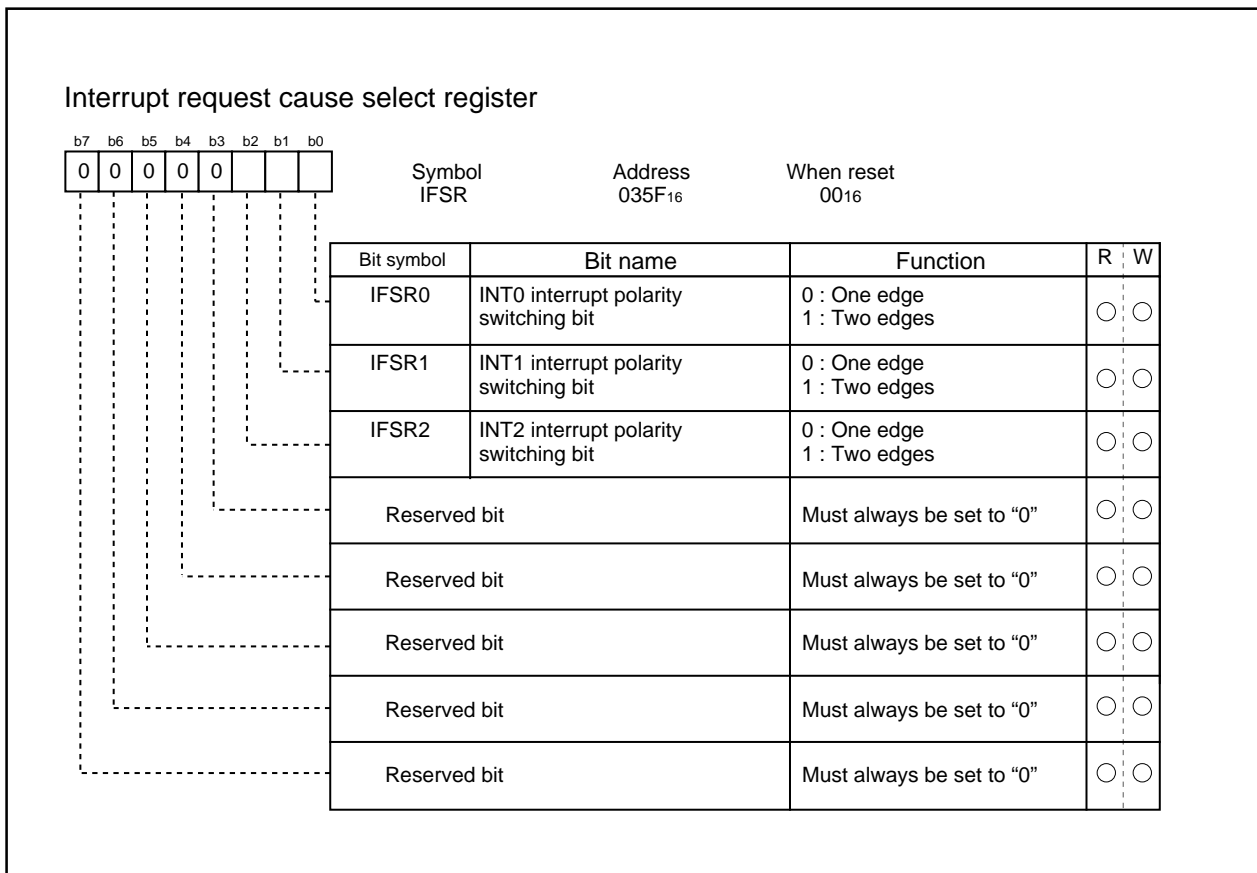

Figure 1.11.10. Interrupt request cause select register

NMI Interrupt

An $\overline{\text{NMI}}$ interrupt is generated when the input to the P85/ $\overline{\text{NMI}}$ pin changes from “H” to “L”. The $\overline{\text{NMI}}$ interrupt is a non-maskable external interrupt. The pin level can be checked in the port P85 register (bit 5 at address 03F016).

This pin cannot be used as a normal port input.

Key Input Interrupt

If the direction register of any of P104 to P107 is set for input and a falling edge is input to that port, a key input interrupt is generated. A key input interrupt can also be used as a key-on wakeup function for canceling the wait mode or stop mode. However, if you intend to use the key input interrupt, do not use P104 to P107 as A-D input ports. Figure 1.11.11 shows the block diagram of the key input interrupt. Note that if an “L” level is input to any pin that has not been disabled for input, inputs to the other pins are not detected as an interrupt.

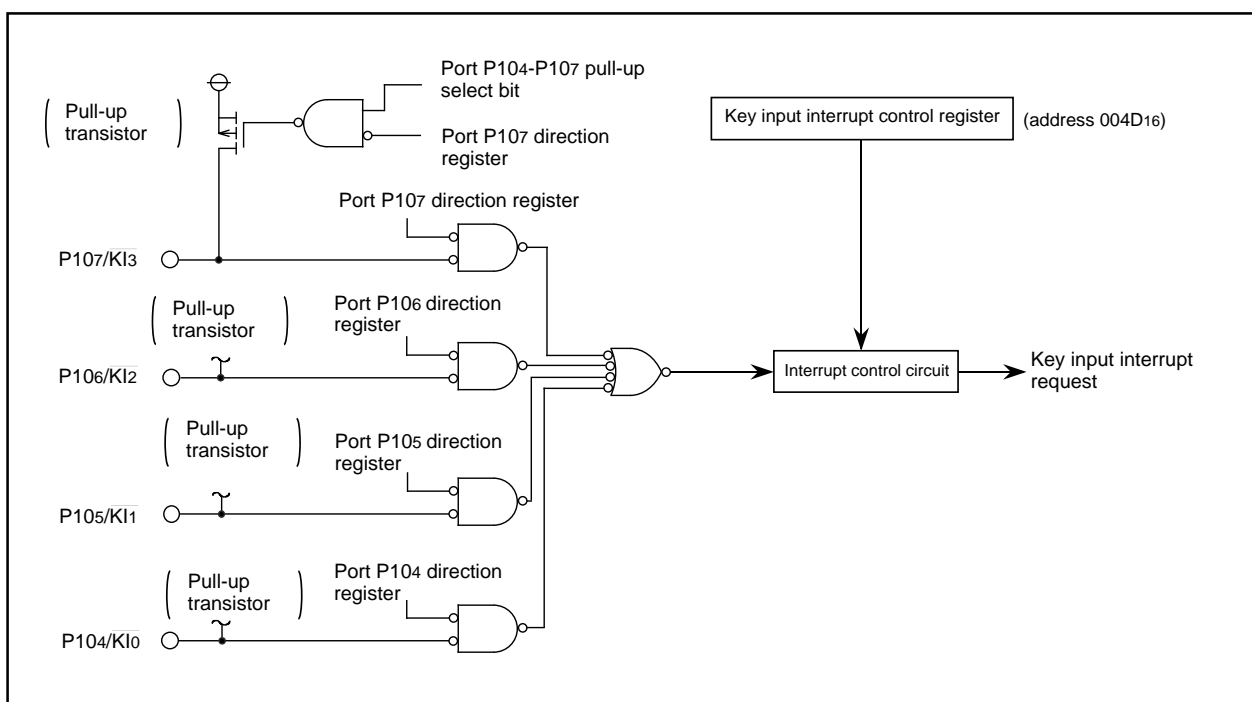

Figure 1.11.11. Block diagram of key input interrupt

Address Match Interrupt

An address match interrupt is generated when the address match interrupt address register contents match the program counter value. Two address match interrupts can be set, each of which can be enabled and disabled by an address match interrupt enable bit. Address match interrupts are not affected by the interrupt enable flag (I flag) and processor interrupt priority level (IPL). For an address match interrupt, the value of the program counter (PC) that is saved to the stack area varies depending on the instruction being executed. Note that when using the external data bus in width of 8 bits, the address match interrupt cannot be used for external area.

Figure 1.11.12 shows the address match interrupt-related registers.

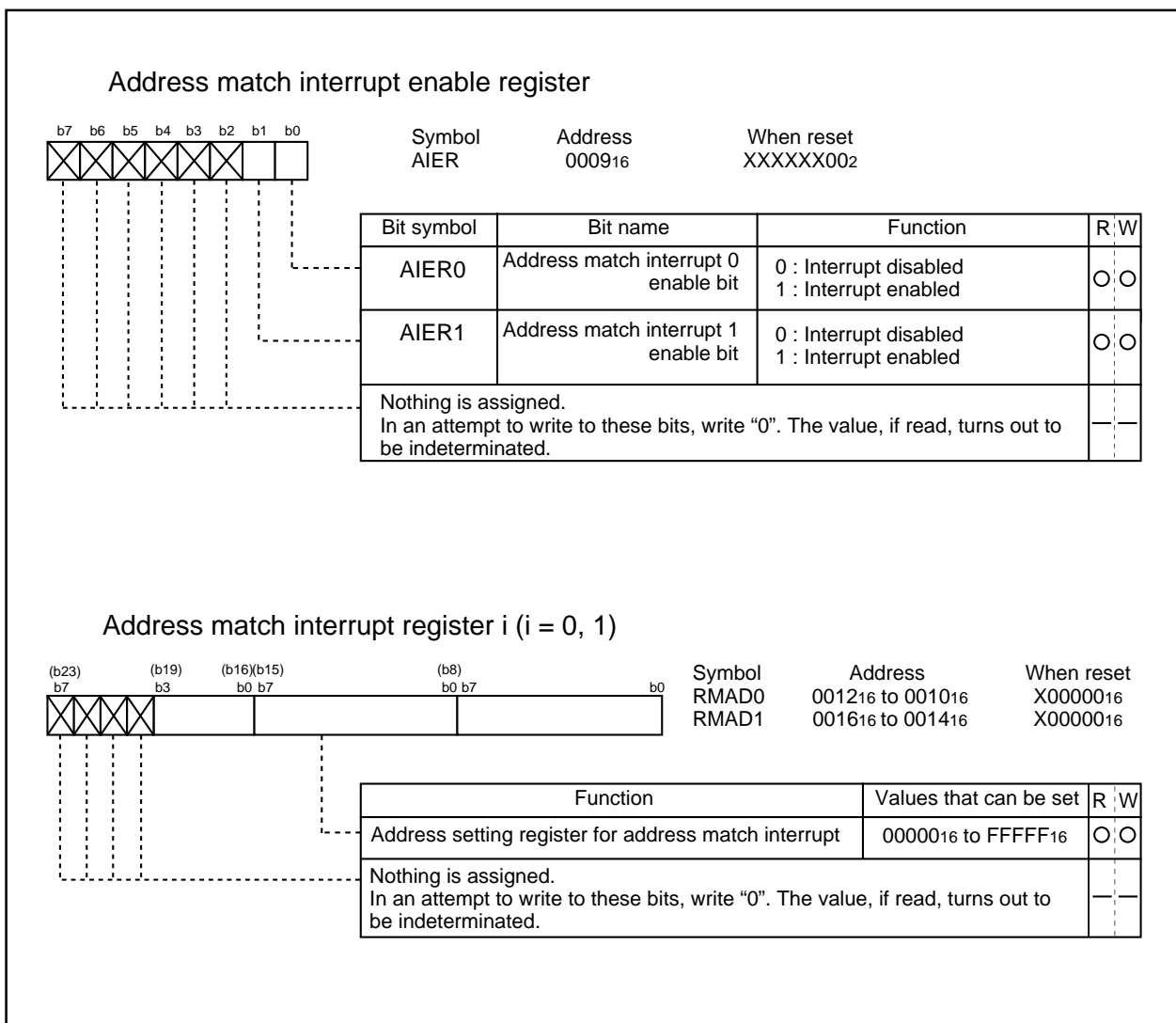

Figure 1.11.12. Address match interrupt-related registers

Precautions for Interrupts

(1) Reading address 00000₁₆

- When maskable interrupt is occurred, CPU reads the interrupt information (the interrupt number and interrupt request level) in the interrupt sequence.

The interrupt request bit of the certain interrupt written in address 00000₁₆ will then be set to "0".

Even if the address 00000₁₆ is read out by software, "0" is set to the enabled highest priority interrupt source request bit. Therefore interrupt can be canceled and unexpected interrupt can occur.

Do not read address 00000₁₆ by software.

(2) Setting the stack pointer

- The value of the stack pointer immediately after reset is initialized to 0000₁₆. Accepting an interrupt before setting a value in the stack pointer may become a factor of runaway. Be sure to set a value in the stack pointer before accepting an interrupt. When using the $\overline{\text{NMI}}$ interrupt, initialize the stack pointer at the beginning of a program. Concerning the first instruction immediately after reset, generating any interrupts including the $\overline{\text{NMI}}$ interrupt is prohibited.

(3) The $\overline{\text{NMI}}$ interrupt

- The $\overline{\text{NMI}}$ interrupt can not be disabled. Be sure to connect $\overline{\text{NMI}}$ pin to Vcc via a pull-up resistor if unused. Be sure to work on it.
- The $\overline{\text{NMI}}$ pin also serves as P85, which is exclusively input. Reading the contents of the P8 register allows reading the pin value. Use the reading of this pin only for establishing the pin level at the time when the $\overline{\text{NMI}}$ interrupt is input.
- Do not attempt to go into stop mode with the input to the $\overline{\text{NMI}}$ pin being in the "L" state. With the input to the $\overline{\text{NMI}}$ being in the "L" state, the CM10 is fixed to "0", so attempting to go into stop mode is turned down.
- Do not attempt to go into wait mode with the input to the $\overline{\text{NMI}}$ pin being in the "L" state. With the input to the $\overline{\text{NMI}}$ pin being in the "L" state, the CPU stops but the oscillation does not stop, so no power is saved. In this instance, the CPU is returned to the normal state by a later interrupt.
- Signals input to the $\overline{\text{NMI}}$ pin require "L" level and "H" level of 2 clock +300ns or more, from the operation clock of the CPU.

(4) External interrupt

- Either an "L" level or an "H" level of at least 250 ns width is necessary for the signal input to pins $\overline{\text{INT}}_0$ through $\overline{\text{INT}}_2$ regardless of the CPU operation clock.
- When the polarity of the $\overline{\text{INT}}_0$ to $\overline{\text{INT}}_2$ pins is changed, the interrupt request bit is sometimes set to "1". After changing the polarity, set the interrupt request bit to "0". Figure 1.11.13 shows the procedure for changing the $\overline{\text{INT}}$ interrupt generate factor.

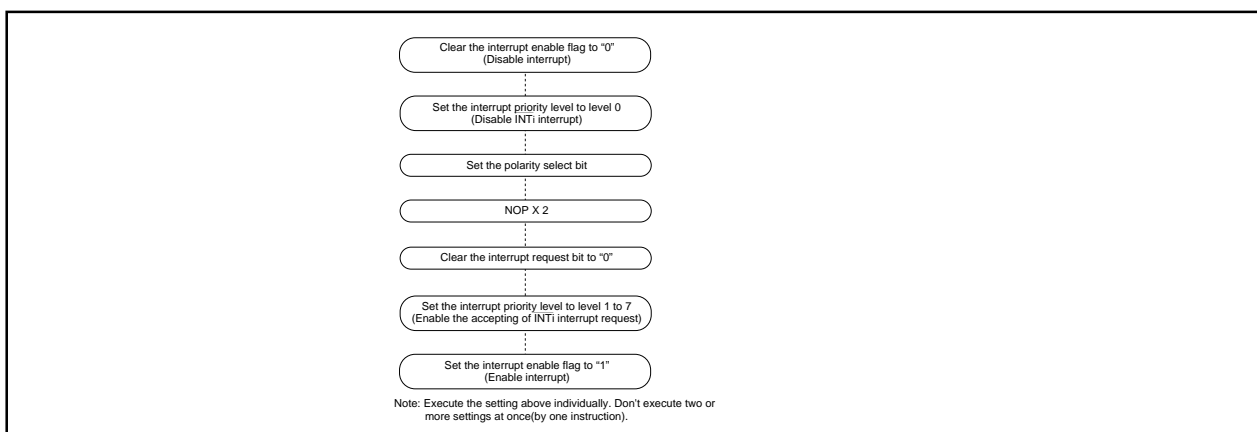

Figure 1.11.13. Switching condition of $\overline{\text{INT}}$ interrupt request

Precautions for Interrupts

(5) Watchdog timer interrupt

- Write to the watchdog timer start register after the watchdog timer interrupt occurs (initialize watchdog timer).

(6) Rewrite the interrupt control register

- To rewrite the interrupt control register, do so at a point that does not generate the interrupt request for that register. If there is possibility of the interrupt request occur, rewrite the interrupt control register after the interrupt is disabled. The program examples are described as follow:

Example 1:

```
INT_SWITCH1:
  FCLR  I           ; Disable interrupts.
  AND.B #00h, 0055h ; Clear TA0IC int. priority level and int. request bit.
  NOP      ; Four NOP instructions are required when using HOLD function.
  NOP
  FSET  I           ; Enable interrupts.
```

Example 2:

```
INT_SWITCH2:
  FCLR  I           ; Disable interrupts.
  AND.B #00h, 0055h ; Clear TA0IC int. priority level and int. request bit.
  MOV.W MEM, R0    ; Dummy read.
  FSET  I           ; Enable interrupts.
```

Example 3:

```
INT_SWITCH3:
  PUSHC FLG        ; Push Flag register onto stack
  FCLR  I           ; Disable interrupts.
  AND.B #00h, 0055h ; Clear TA0IC int. priority level and int. request bit.
  POPC  FLG        ; Enable interrupts.
```

The reason why two NOP instructions (four when using the HOLD function) or dummy read are inserted before FSET I in Examples 1 and 2 is to prevent the interrupt enable flag I from being set before the interrupt control register is rewritten due to effects of the instruction queue.

When changing an interrupt control register in a state of interrupts being disabled, please read the following precautions on instructions used before changing the register.

Changing a non-interrupt request bit

If an interrupt request for an interrupt control register is generated during an instruction to rewrite the register is being executed, there is a case that the interrupt request bit is not set and consequently the interrupt is ignored. This will depend on the instruction. If this creates problems, use the below instructions to change the register.

Instructions : AND, OR, BCLR, BSET

Changing the interrupt request bit

When attempting to clear the interrupt request bit of an interrupt control register, the interrupt request bit is not cleared sometimes. This will depend on the instruction. If this creates problems, use the below instructions to change the register.

Instructions : MOV

Watchdog Timer

The watchdog timer has the function of detecting when the program is out of control. Therefore, we recommend using the watchdog timer to improve reliability of a system. The watchdog timer is a 15-bit counter which down-counts the clock derived by dividing the BCLK using the prescaler. Whether a watchdog timer interrupt is generated or reset is selected when an underflow occurs in the watchdog timer. When the watchdog timer interrupt is selected, write to the watchdog timer start register after the watchdog timer interrupt occurs (initialize watchdog timer). Watchdog timer interrupt is selected when bit 2 (PM12) of the processor mode register 1 (address 0005₁₆) is "0" and reset is selected when PM12 is "1". No value other than "1" can be written in PM12. Once when reset is selected (PM12="1"), watchdog timer interrupt cannot be selected by software.

When X_{IN} is selected for the BCLK, bit 7 of the watchdog timer control register (address 000F₁₆) selects the prescaler division ratio (by 16 or by 128). When X_{CIN} is selected as the BCLK, the prescaler is set for division by 2 regardless of bit 7 of the watchdog timer control register (address 000F₁₆). Thus the watchdog timer's period can be calculated as given below. The watchdog timer's period is, however, subject to an error due to the prescaler.

With X_{IN} chosen for BCLK

$$\text{Watchdog timer period} = \frac{\text{prescaler dividing ratio (16 or 128)} \times \text{watchdog timer count (32768)}}{\text{BCLK}}$$

With X_{CIN} chosen for BCLK

$$\text{Watchdog timer period} = \frac{\text{prescaler dividing ratio (2)} \times \text{watchdog timer count (32768)}}{\text{BCLK}}$$

For example, suppose that BCLK runs at 16 MHz and that 16 has been chosen for the dividing ratio of the prescaler, then the watchdog timer's period becomes approximately 32.8 ms.

The watchdog timer is initialized by writing to the watchdog timer start register (address 000E₁₆) and when a watchdog timer interrupt request is generated. The prescaler is initialized only when the microcomputer is reset. After a reset is cancelled, the watchdog timer and prescaler are both stopped. The count is started by writing to the watchdog timer start register (address 000E₁₆). In stop mode, wait mode and hold state, the watchdog timer and prescaler are stopped. Counting is resumed from the held value when the modes or state are released.

Also PM12 is initialized only when reset. The watchdog timer interrupt is selected after reset is cancelled. Figure 1.12.1 shows the block diagram of the watchdog timer. Figure 1.12.2 shows the watchdog timer-related registers.

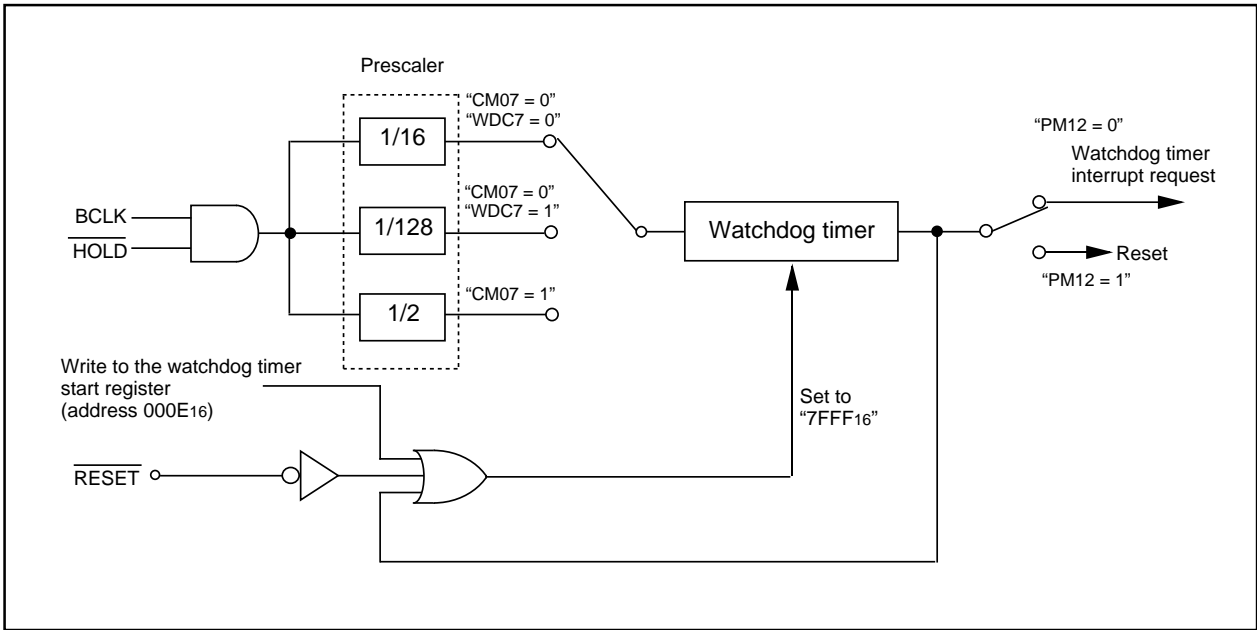

Figure 1.12.1. Block diagram of watchdog timer

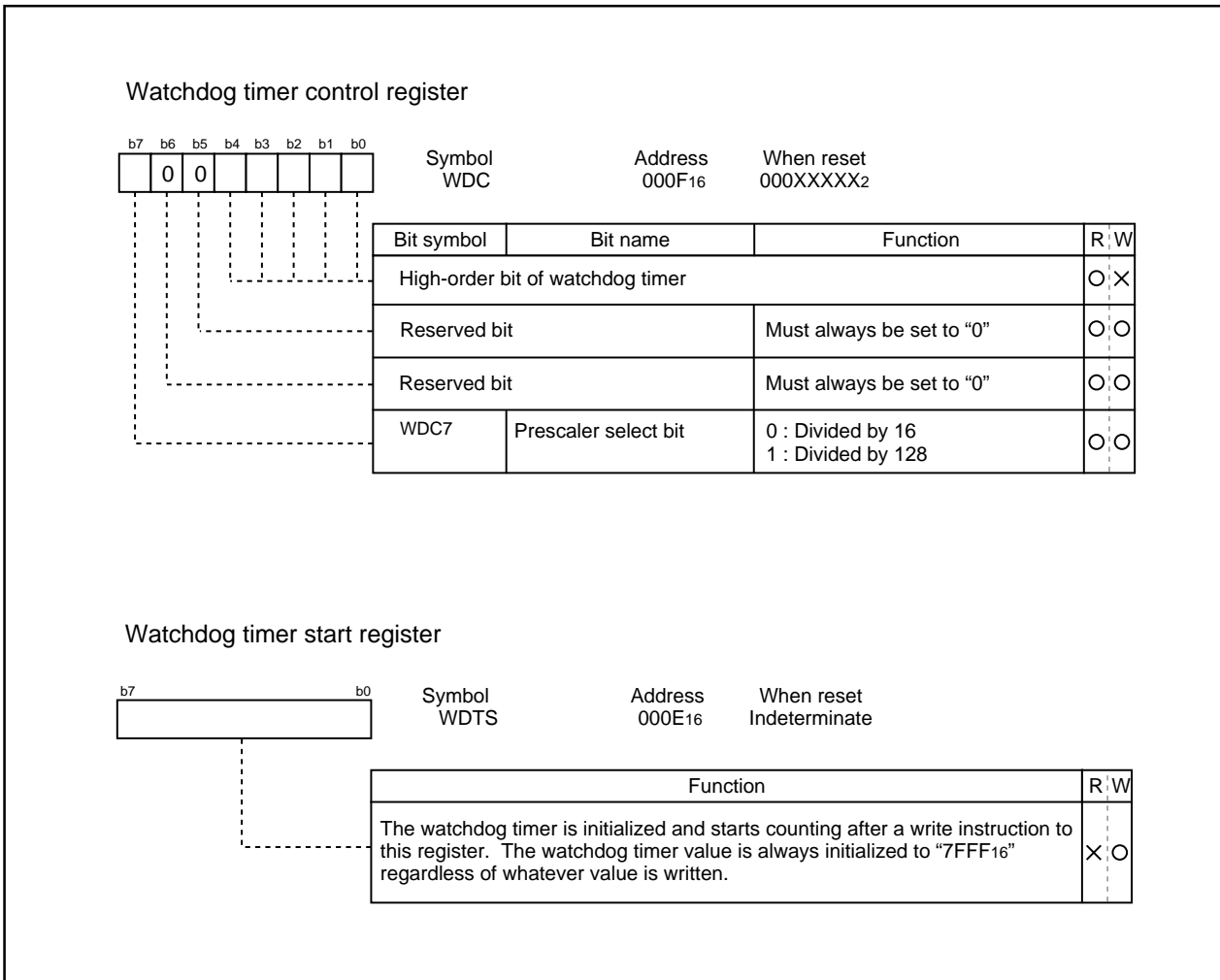

Figure 1.12.2. Watchdog timer control and start registers

DMAC

This microcomputer has one DMAC (direct memory access controller) channel that allow data to be sent to memory without using the CPU. DMAC shares the same data bus with the CPU. The DMAC is given a higher right of using the bus than the CPU, which leads to working the cycle stealing method. On this account, the operation from the occurrence of DMA transfer request signal to the completion of 1-word (16-bit) or 1-byte (8-bit) data transfer can be performed at high speed. Figure 1.13.1 shows the block diagram of the DMAC. Table 1.13.1 shows the DMAC specifications. Figures 1.13.2 to 1.13.4 show the registers used by the DMAC.

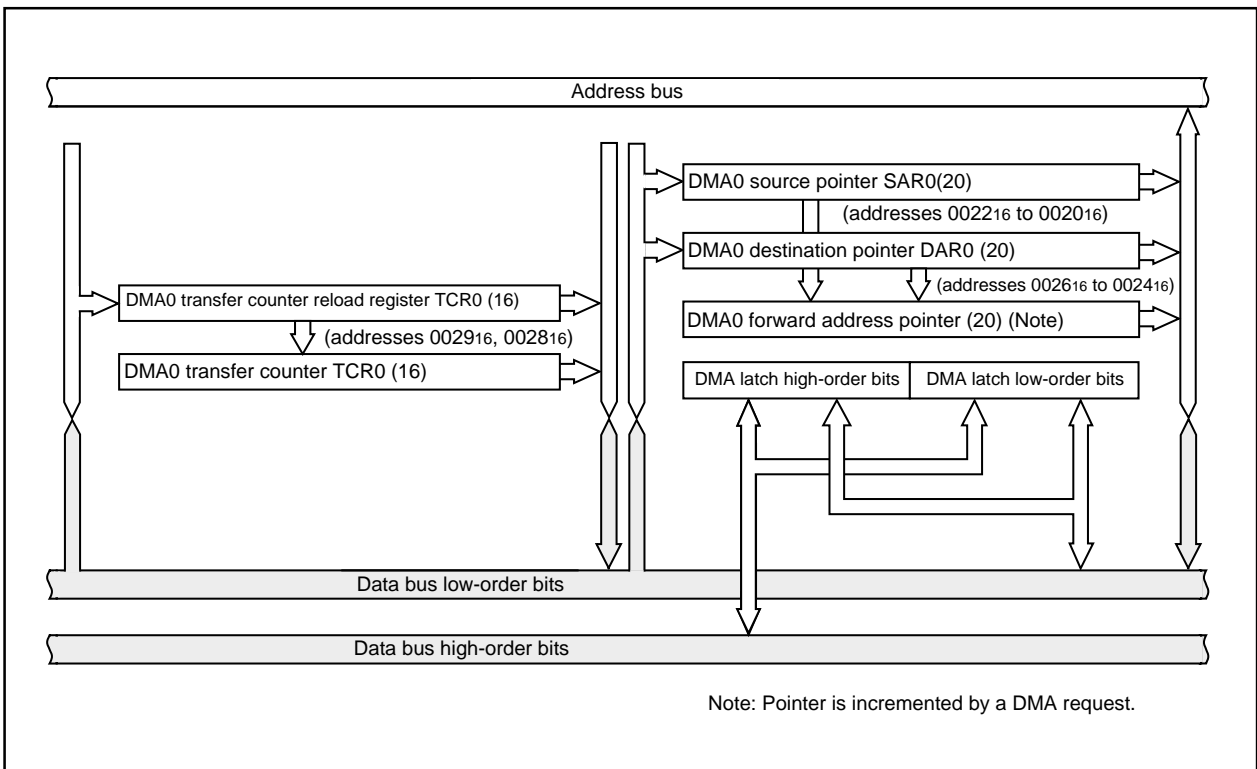

Figure 1.13.1. Block diagram of DMAC

Either a write signal to the software DMA request bit or an interrupt request signal is used as a DMA transfer request signal. But the DMA transfer is affected neither by the interrupt enable flag (I flag) nor by the interrupt priority level. The DMA transfer doesn't affect any interrupts either.

If the DMAC is active (the DMA enable bit is set to 1), data transfer starts every time a DMA transfer request signal occurs. If the cycle of the occurrences of DMA transfer request signals is higher than the DMA transfer cycle, there can be instances in which the number of transfer requests doesn't agree with the number of transfers. For details, see the description of the DMA request bit.

Table 1.13.1. DMAC specifications

Item	Specification
No. of channels	2 (cycle steal method)
Transfer memory space	<ul style="list-style-type: none"> • From any address in the 1M bytes space to a fixed address • From a fixed address to any address in the 1M bytes space • From a fixed address to a fixed address (Note that DMA-related registers [0020 ₁₆ to 003F ₁₆] cannot be accessed)
Maximum No. of bytes transferred	128K bytes (with 16-bit transfers) or 64K bytes (with 8-bit transfers)
DMA request factors (Note)	Falling edge of $\overline{\text{INT0}}$ or both edge Timer A0 to timer A2 interrupt requests Timer B1 and timer B2 interrupt requests UART0 transfer and reception interrupt requests UART1 transfer and reception interrupt requests UART2 transfer and reception interrupt requests A-D conversion interrupt requests Software triggers
Transfer unit	8 bits or 16 bits
Transfer address direction	forward/fixed (forward direction cannot be specified for both source and destination simultaneously)
Transfer mode	<ul style="list-style-type: none"> • Single transfer mode After the transfer counter underflows, the DMA enable bit turns to "0", and the DMAC turns inactive • Repeat transfer mode After the transfer counter underflows, the value of the transfer counter reload register is reloaded to the transfer counter. The DMAC remains active unless a "0" is written to the DMA enable bit.
DMA interrupt request generation timing	When an underflow occurs in the transfer counter
Active	When the DMA enable bit is set to "1". When the DMAC is active, data transfer starts every time a DMA transfer request signal occurs.
Inactive	<ul style="list-style-type: none"> • When the DMA enable bit is set to "0".
Reload timing for forward address pointer and transfer counter	At the time of starting data transfer immediately after turning the DMAC active, the value of one of source pointer and destination pointer - the one specified for the forward direction - is reloaded to the forward direction address pointer, and the value of the transfer counter reload register is reloaded to the transfer counter.
Writing to register	Registers specified for forward direction transfer are always write enabled. Registers specified for fixed address transfer are write-enabled when the DMA enable bit is "0".
Reading the register	Can be read at any time. However, when the DMA enable bit is "1", reading the register set up as the forward register is the same as reading the value of the forward address pointer.

Note: DMA transfer is not effective to any interrupt. DMA transfer is affected neither by the interrupt enable flag (I flag) nor by the interrupt priority level.

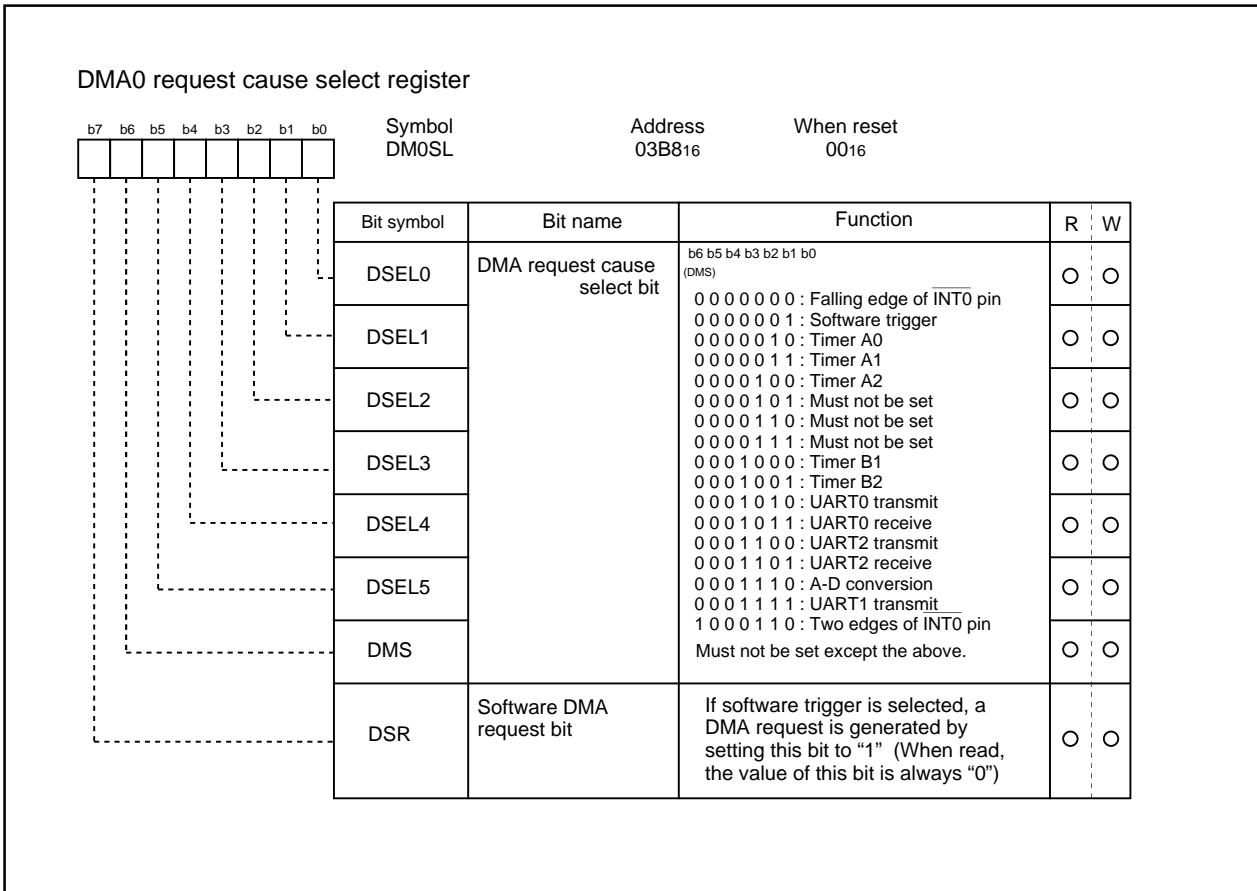

Figure 1.13.2. DMAC register (1)

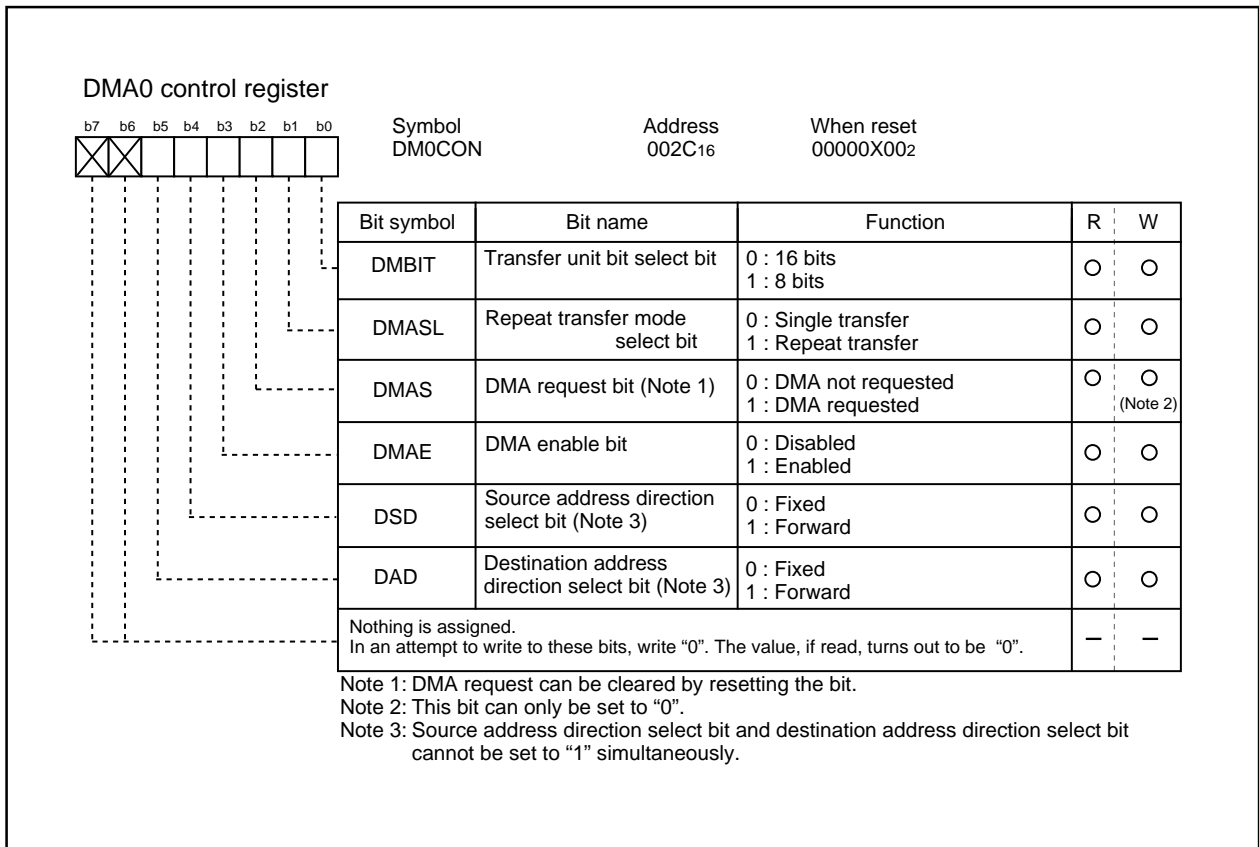

Figure 1.13.3. DMAC register (2)

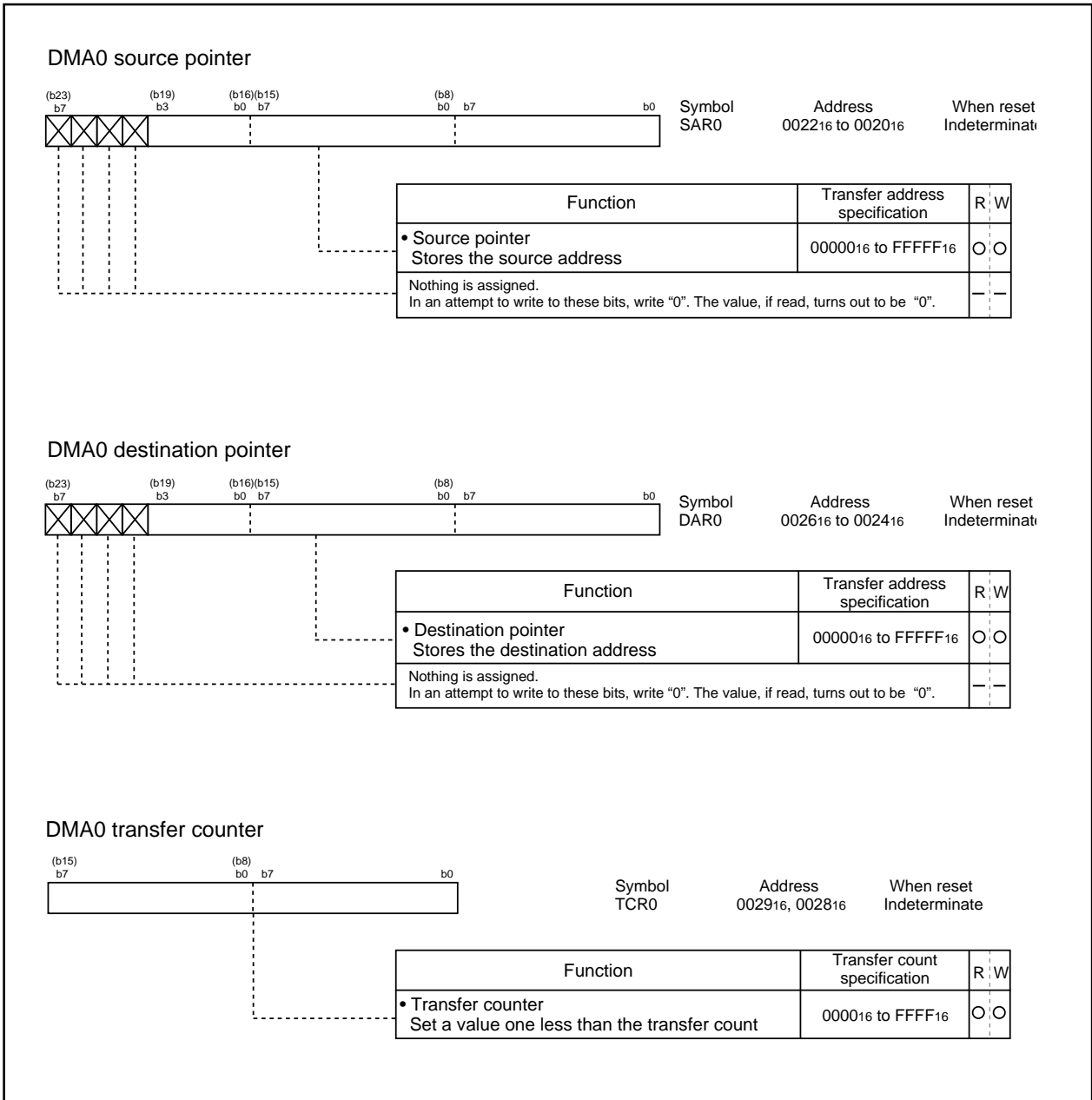

Figure 1.13.4. DMAC register (3)

(1) Transfer cycle

The transfer cycle consists of the bus cycle in which data is read from memory or from the SFR area (source read) and the bus cycle in which the data is written to memory or to the SFR area (destination write). The number of read and write bus cycles depends on the source and destination addresses. In memory expansion mode and microprocessor mode, the number of read and write bus cycles also depends on the level of the BYTE pin. Also, the bus cycle itself is longer when software waits are inserted.

(a) Effect of source and destination addresses

When 16-bit data is transferred on a 16-bit data bus, and the source and destination both start at odd addresses, there are one more source read cycle and destination write cycle than when the source and destination both start at even addresses.

(b) Effect of BYTE pin level

When transferring 16-bit data over an 8-bit data bus (BYTE pin = "H") in memory expansion mode and microprocessor mode, the 16 bits of data are sent in two 8-bit blocks. Therefore, two bus cycles are required for reading the data and two are required for writing the data. Also, in contrast to when the CPU accesses internal memory, when the DMAC accesses internal memory (internal ROM, internal RAM, and SFR), these areas are accessed using the data size selected by the BYTE pin.

(c) Effect of software wait

When the SFR area or a memory area with a software wait is accessed, the number of cycles is increased for the wait by 1 bus cycle. The length of the cycle is determined by BCLK.

Figure 1.13.5 shows the example of the transfer cycles for a source read. For convenience, the destination write cycle is shown as one cycle and the source read cycles for the different conditions are shown. In reality, the destination write cycle is subject to the same conditions as the source read cycle, with the transfer cycle changing accordingly. When calculating the transfer cycle, remember to apply the respective conditions to both the destination write cycle and the source read cycle. For example (2) in Figure 1.13.5, if data is being transferred in 16-bit units on an 8-bit bus, two bus cycles are required for both the source read cycle and the destination write cycle.

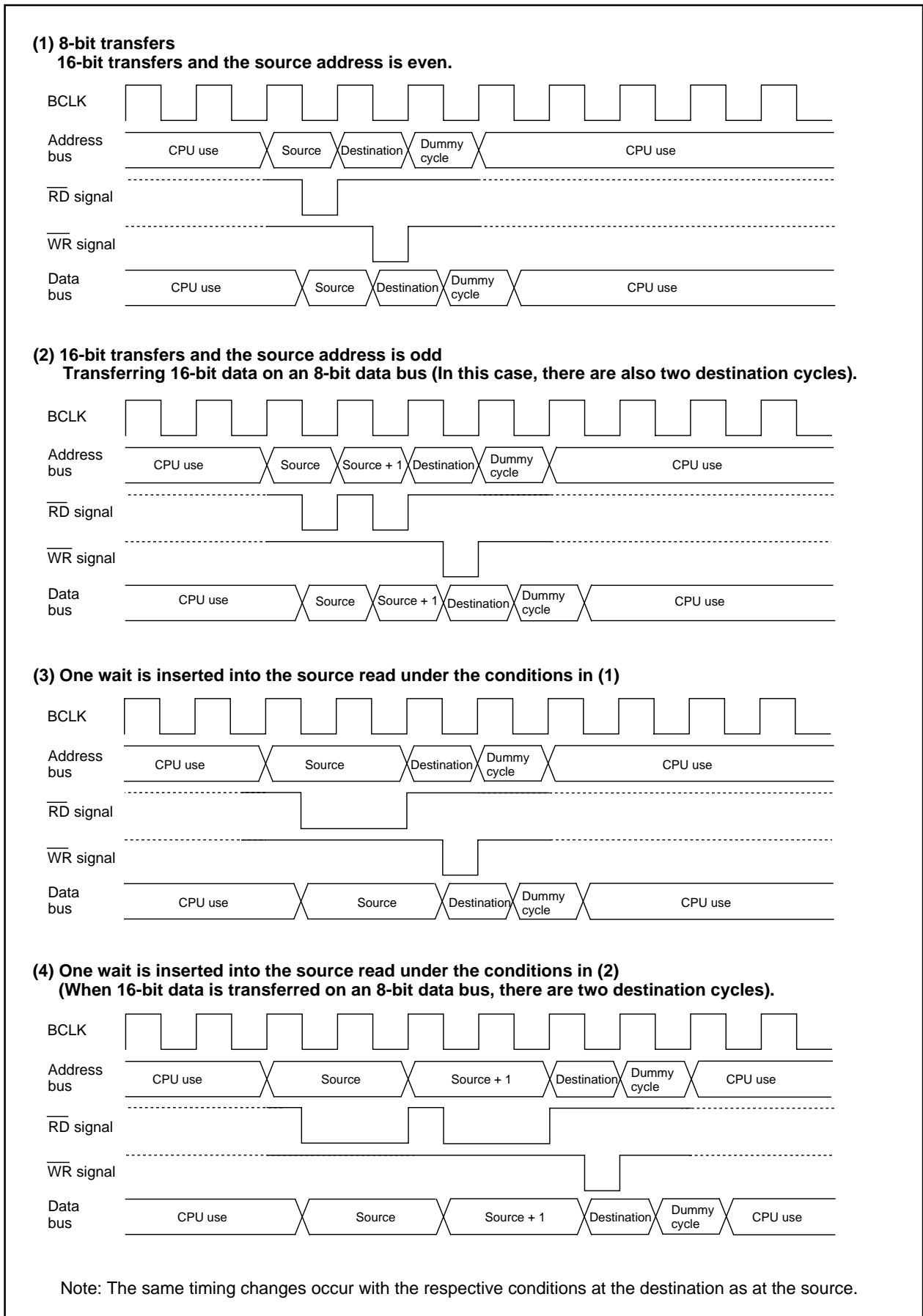

Figure 1.13.5. Example of the transfer cycles for a source read

(2) DMAC transfer cycles

Any combination of even or odd transfer read and write addresses is possible. Table 1.13.2 shows the number of DMAC transfer cycles.

The number of DMAC transfer cycles can be calculated as follows:

$$\text{No. of transfer cycles per transfer unit} = \text{No. of read cycles} \times j + \text{No. of write cycles} \times k$$

Table 1.13.2. No. of DMAC transfer cycles

Transfer unit	Bus width	Access address	Single-chip mode		Memory expansion mode Microprocessor mode	
			No. of read cycles	No. of write cycles	No. of read cycles	No. of write cycles
8-bit transfers (DMBIT= "1")	16-bit (BYTE= "L")	Even	1	1	1	1
		Odd	1	1	1	1
	8-bit (BYTE = "H")	Even	—	—	1	1
		Odd	—	—	1	1
16-bit transfers (DMBIT= "0")	16-bit (BYTE = "L")	Even	1	1	1	1
		Odd	2	2	2	2
	8-bit (BYTE = "H")	Even	—	—	2	2
		Odd	—	—	2	2

Coefficient j, k

Internal memory			External memory		
Internal ROM/RAM No wait	Internal ROM/RAM With wait	SFR area	Separate bus No wait	Separate bus With wait	Multiplex bus
1	2	2	1	2	3

DMA enable bit

Setting the DMA enable bit to "1" makes the DMAC active. The DMAC carries out the following operations at the time data transfer starts immediately after DMAC is turned active.

- (1) Reloads the value of one of the source pointer and the destination pointer - the one specified for the forward direction - to the forward direction address pointer.
- (2) Reloads the value of the transfer counter reload register to the transfer counter.

Thus overwriting "1" to the DMA enable bit with the DMAC being active carries out the operations given above, so the DMAC operates again from the initial state at the instant "1" is overwritten to the DMA enable bit.

DMA request bit

The DMAC can generate a DMA transfer request signal triggered by a factor chosen in advance out of DMA request factors.

DMA request factors include the following.

* Factors effected by using the interrupt request signals from the built-in peripheral functions and software DMA factors (internal factors) effected by a program.

* External factors effected by utilizing the input from external interrupt signals.

For the selection of DMA request factors, see the descriptions of the DMA0 factor selection register.

The DMA request bit turns to "1" if the DMA transfer request signal occurs regardless of the DMAC's state (regardless of whether the DMA enable bit is set to "1" or "0"). It turns to "0" immediately before data transfer starts.

In addition, it can be set to "0" by use of a program, but cannot be set to "1".

There can be instances in which a change in DMA request factor selection bit causes the DMA request bit to turn to "1". So be sure to set the DMA request bit to "0" after the DMA request factor selection bit is changed.

The DMA request bit turns to "1" if a DMA transfer request signal occurs, and turns to "0" immediately before data transfer starts. If the DMAC is active, data transfer starts immediately, so the value of the DMA request bit, if read by use of a program, turns out to be "0" in most cases. To examine whether the DMAC is active, read the DMA enable bit.

Here follows the timing of changes in the DMA request bit.

(1) Internal factors

Except the DMA request factors triggered by software, the timing for the DMA request bit to turn to "1" due to an internal factor is the same as the timing for the interrupt request bit of the interrupt control register to turn to "1" due to several factors.

Turning the DMA request bit to "0" due to an internal factor is timed to be effected immediately before the transfer starts.

(2) External factors

An external factor is a factor caused to occur by the leading edge of input from the $\overline{\text{INT0}}$ pin.

Selecting the $\overline{\text{INT0}}$ pins as external factors using the DMA request factor selection bit causes input from these pins to become the DMA transfer request signals.

The timing for the DMA request bit to turn to "1" when an external factor is selected synchronizes with the signal's edge applicable to the function specified by the DMA request factor selection bit (synchronizes with the trailing edge of the input signal to $\overline{\text{INT0}}$ pin, for example).

With an external factor selected, the DMA request bit is timed to turn to "0" immediately before data transfer starts similarly to the state in which an internal factor is selected.

Timer

There are five 16-bit timers. These timers can be classified by function into timers A (three) and timers B (two). All these timers function independently. Figures 1.14.1 and 1.14.2 show the block diagram of timers.

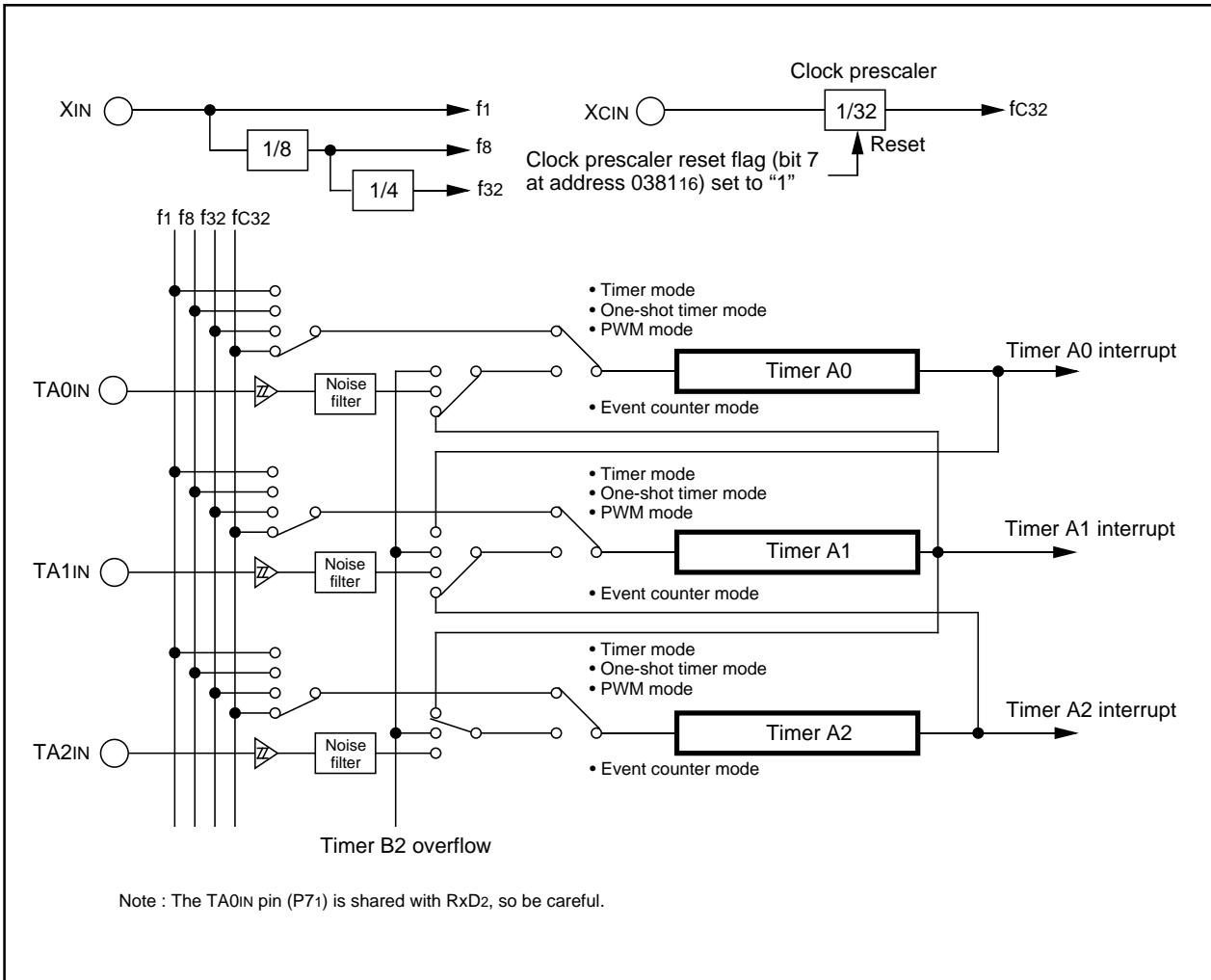

Figure 1.14.1. Timer A block diagram

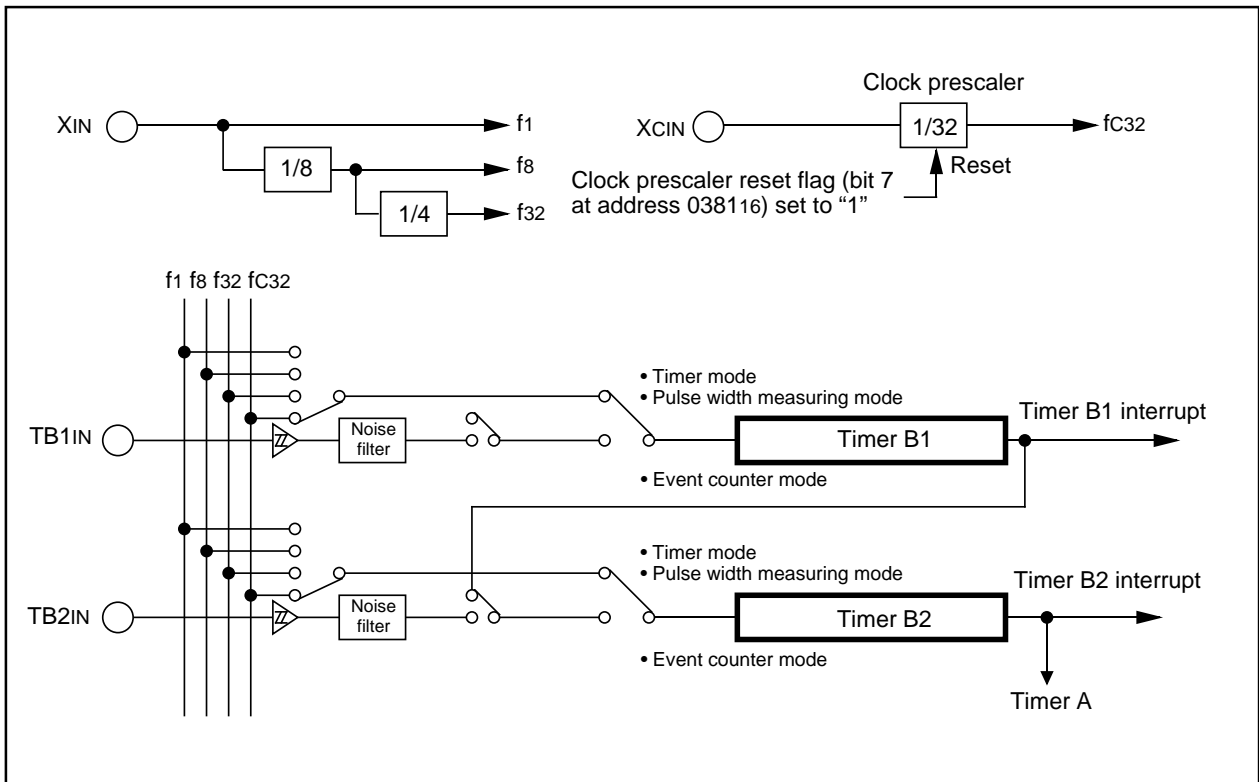

Figure 1.14.2. Timer B block diagram

Timer A

Timer A

Figure 1.14.3 shows the block diagram of timer A. Figures 1.14.4 to 1.14.6 show the timer A-related registers.

Except in event counter mode, timers A0 through A2 all have the same function. Use the timer Ai mode register (i = 0 to 2) bits 0 and 1 to choose the desired mode.

Timer A has the four operation modes listed as follows:

- Timer mode: The timer counts an internal count source.
- Event counter mode: The timer counts pulses from an external source or a timer overflow.
- One-shot timer mode: The timer stops counting when the count reaches "000016".
- Pulse width modulation (PWM) mode: The timer outputs pulses of a given width.

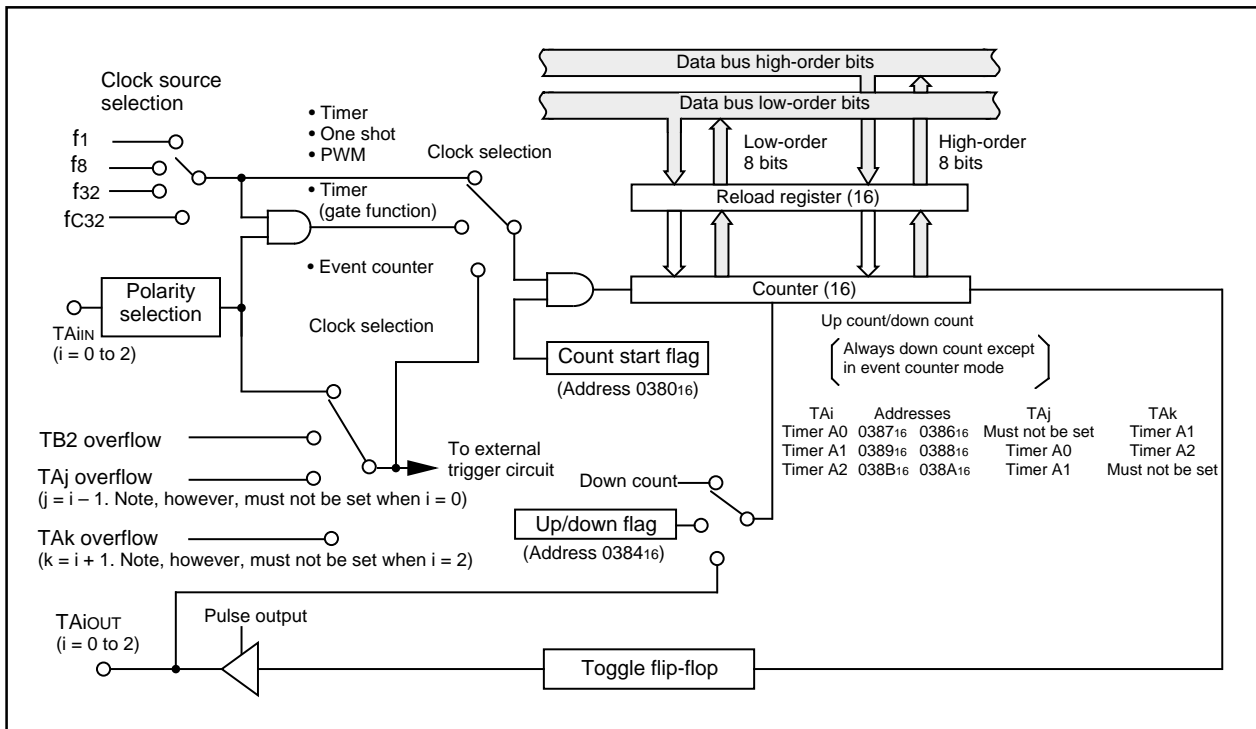

Figure 1.14.3. Block diagram of timer A

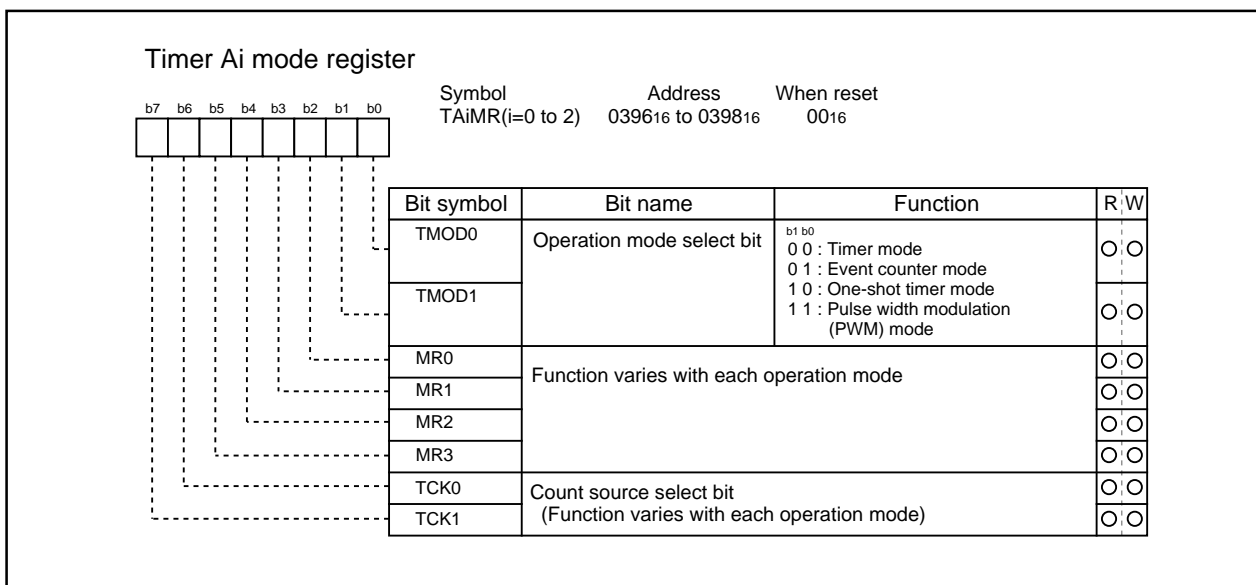

Figure 1.14.4. Timer A-related registers (1)

Timer A

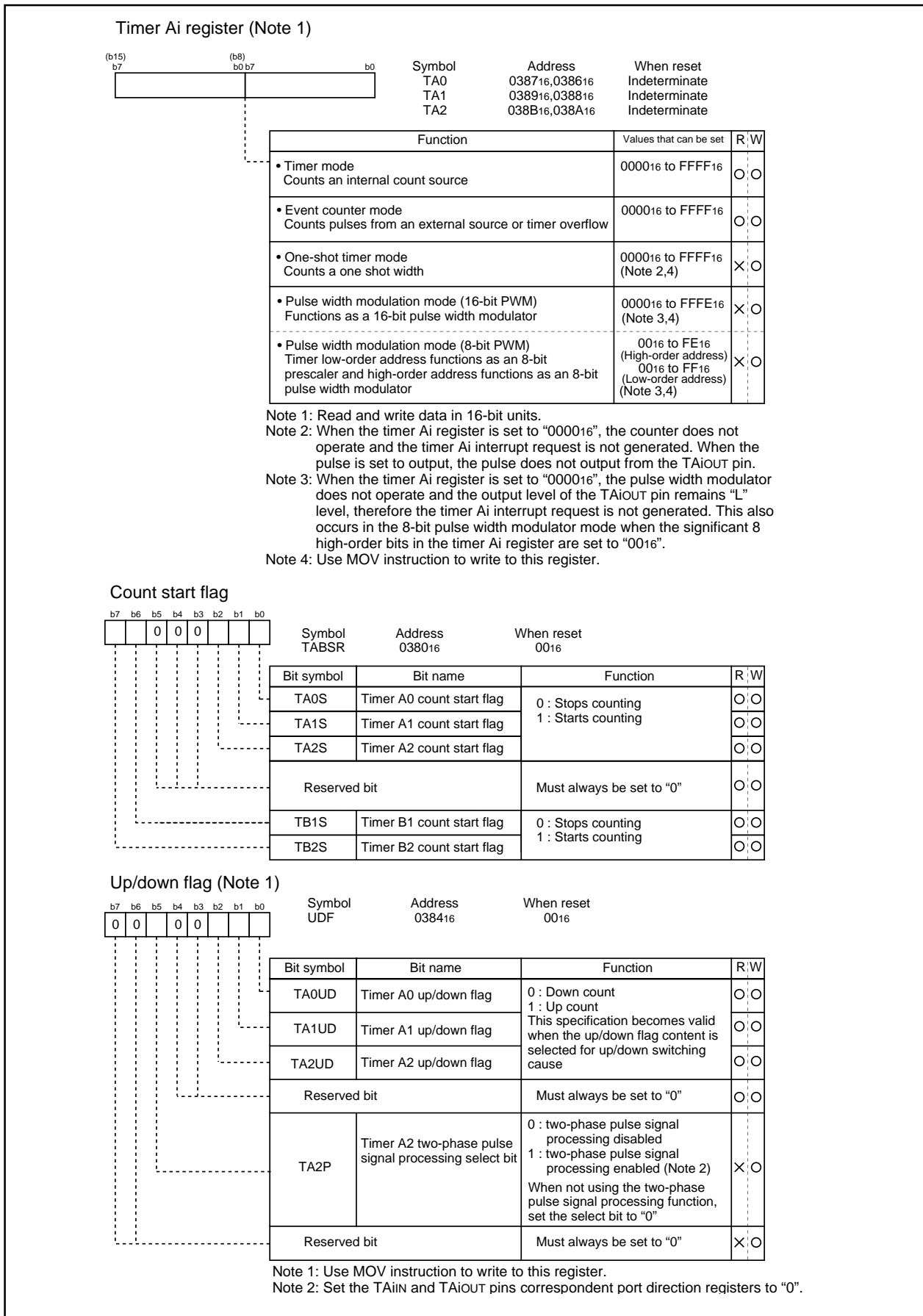

Figure 1.14.5. Timer A-related registers (2)

Timer A

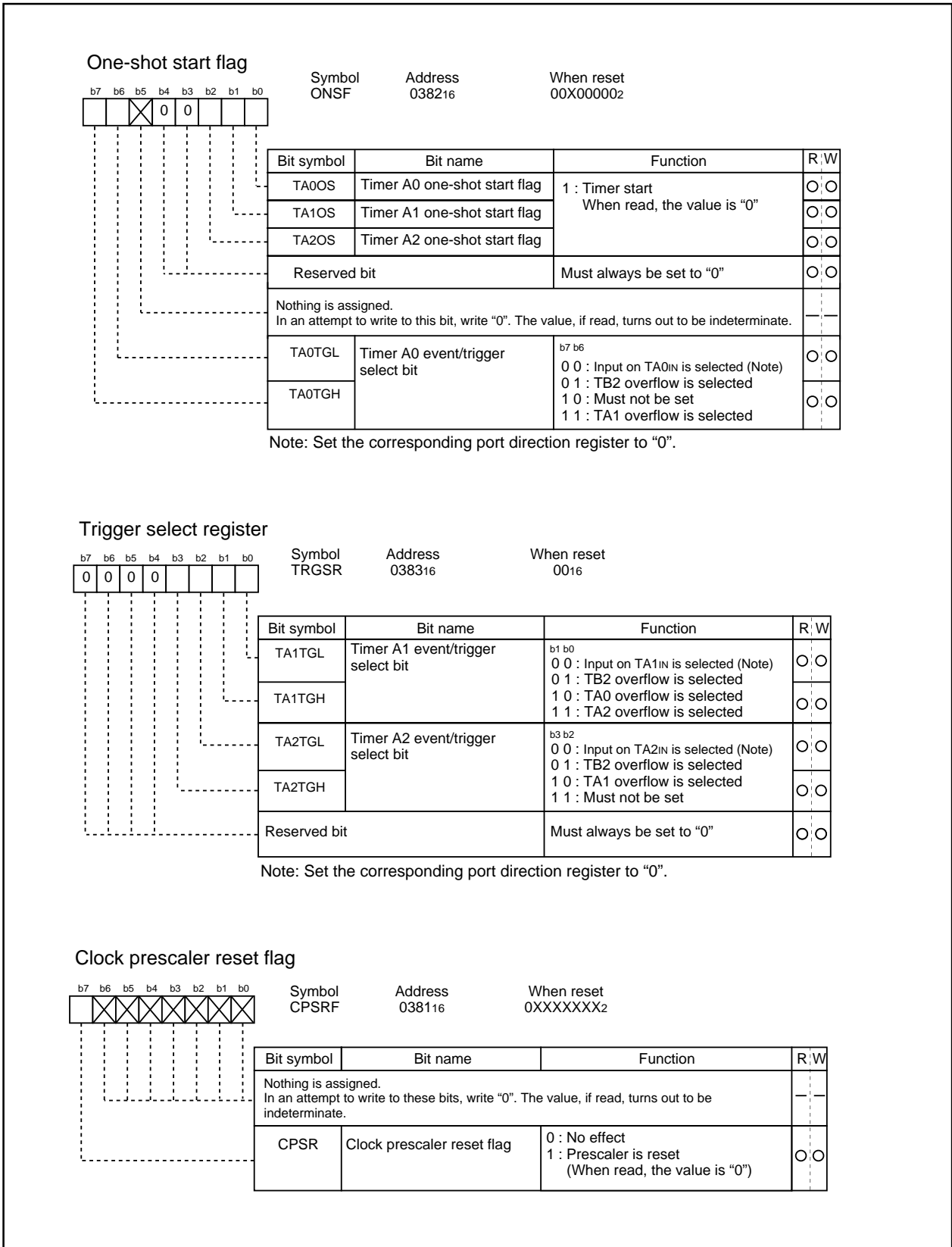

Figure 1.14.6. Timer A-related registers (3)

Timer A

(1) Timer mode

In this mode, the timer counts an internally generated count source. (See Table 1.14.1.) Figure 1.14.7 shows the timer Ai mode register in timer mode.

Table 1.14.1. Specifications of timer mode

Item	Specification
Count source	f1, f8, f32, fc32
Count operation	<ul style="list-style-type: none"> • Down count • When the timer underflows, it reloads the reload register contents before continuing counting
Divide ratio	1/(n+1) n : Set value
Count start condition	Count start flag is set (= 1)
Count stop condition	Count start flag is reset (= 0)
Interrupt request generation timing	When the timer underflows
TAiIN pin function	Programmable I/O port or gate input
TAiOUT pin function	Programmable I/O port or pulse output
Read from timer	Count value can be read out by reading timer Ai register
Write to timer	<ul style="list-style-type: none"> • When counting stopped When a value is written to timer Ai register, it is written to both reload register and counter • When counting in progress When a value is written to timer Ai register, it is written to only reload register (Transferred to counter at next reload time)
Select function	<ul style="list-style-type: none"> • Gate function Counting can be started and stopped by the TAiIN pin's input signal • Pulse output function Each time the timer underflows, the TAiOUT pin's polarity is reversed

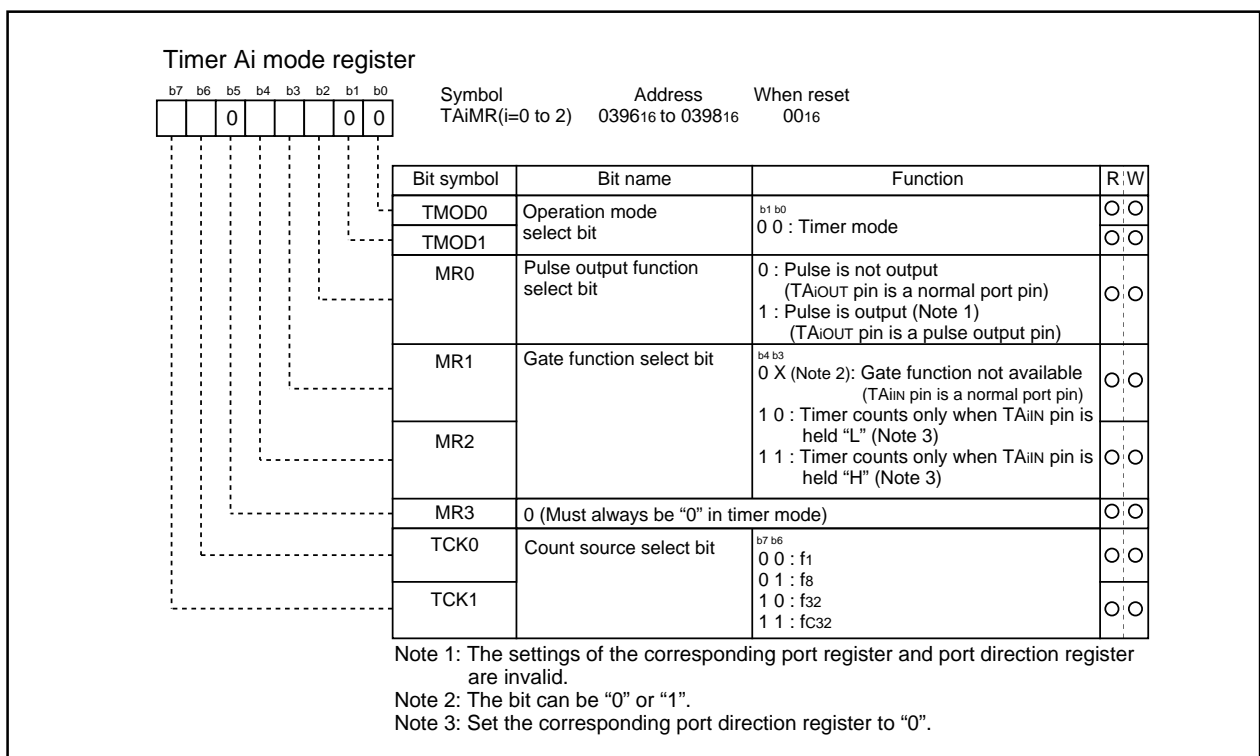

Figure 1.14.7. Timer Ai mode register in timer mode

Timer A

(2) Event counter mode

In this mode, the timer counts an external signal or an internal timer's overflow. Timers A0 and A1 can count a single-phase external signal. Timer A2 can count a single-phase and a two-phase external signal. Table 1.14.2 lists timer specifications when counting a single-phase external signal. Figure 1.14.8 shows the timer Ai mode register in event counter mode.

Table 1.14.3 lists timer specifications when counting a two-phase external signal. Figure 1.14.9 shows the timer Ai mode register in event counter mode.

Table 1.14.2. Timer specifications in event counter mode (when not processing two-phase pulse signal)

Item	Specification
Count source	<ul style="list-style-type: none"> External signals input to TAIin pin (effective edge can be selected by software) TB2 overflow, TAJ overflow
Count operation	<ul style="list-style-type: none"> Up count or down count can be selected by external signal or software When the timer overflows or underflows, it reloads the reload register contents before continuing counting (Note)
Divide ratio	$1 / (FFFF_{16} - n + 1)$ for up count $1 / (n + 1)$ for down count n : Set value
Count start condition	Count start flag is set (= 1)
Count stop condition	Count start flag is reset (= 0)
Interrupt request generation timing	The timer overflows or underflows
TAIin pin function	Programmable I/O port or count source input
TAIOUT pin function	Programmable I/O port, pulse output, or up/down count select input
Read from timer	Count value can be read out by reading timer Ai register
Write to timer	<ul style="list-style-type: none"> When counting stopped When a value is written to timer Ai register, it is written to both reload register and counter When counting in progress When a value is written to timer Ai register, it is written to only reload register (Transferred to counter at next reload time)
Select function	<ul style="list-style-type: none"> Free-run count function Even when the timer overflows or underflows, the reload register content is not reloaded to it Pulse output function Each time the timer overflows or underflows, the TAIOUT pin's polarity is reversed

Note: This does not apply when the free-run function is selected.

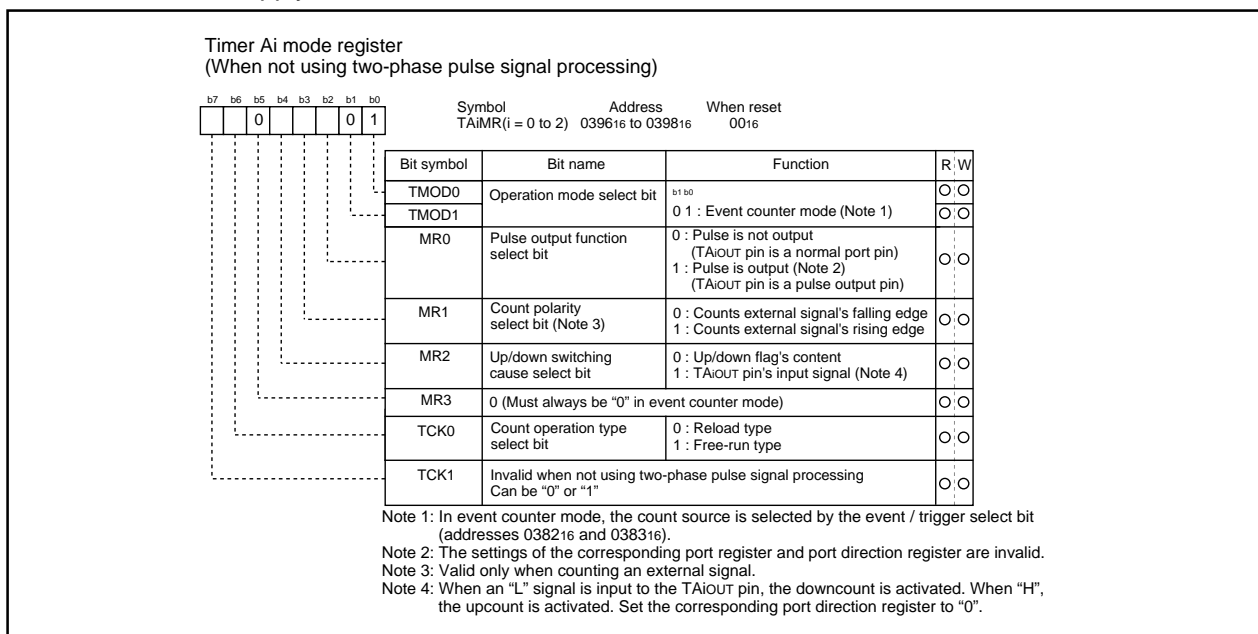
**Figure 1.14.8. Timer Ai mode register in event counter mode**

Timer A

Table 1.14.3. Timer specifications in event counter mode (when processing two-phase pulse signal with timer A2)

Item	Specification
Count source	<ul style="list-style-type: none"> Two-phase pulse signals input to TA2IN or TA2OUT pin
Count operation	<ul style="list-style-type: none"> Up count or down count can be selected by two-phase pulse signal When the timer overflows or underflows, the reload register content is reloaded and the timer starts over again (Note)
Divide ratio	$1 / (FFFF_{16} - n + 1)$ for up count $1 / (n + 1)$ for down count n : Set value
Count start condition	Count start flag is set (= 1)
Count stop condition	Count start flag is reset (= 0)
Interrupt request generation timing	Timer overflows or underflows
TA2IN pin function	Two-phase pulse input (Set the TA2IN pin correspondent port direction register to "0".)
TA2OUT pin function	Two-phase pulse input (Set the TA2OUT pin correspondent port direction register to "0".)
Read from timer	Count value can be read out by reading timer A2 register
Write to timer	<ul style="list-style-type: none"> When counting stopped When a value is written to timer A2 register, it is written to both reload register and counter When counting in progress When a value is written to timer A2 register, it is written to only reload register. (Transferred to counter at next reload time.)
Select function	<ul style="list-style-type: none"> Normal processing operation The timer counts up rising edges or counts down falling edges on the TA2IN pin when input signal on the TA2OUT pin is "H". <div style="text-align: center;"> <p>TA2OUT</p> <p>TA2IN</p> <p>Up count Up count Up count Down count Down count Down count</p> </div>

Note: This does not apply when the free-run function is selected.

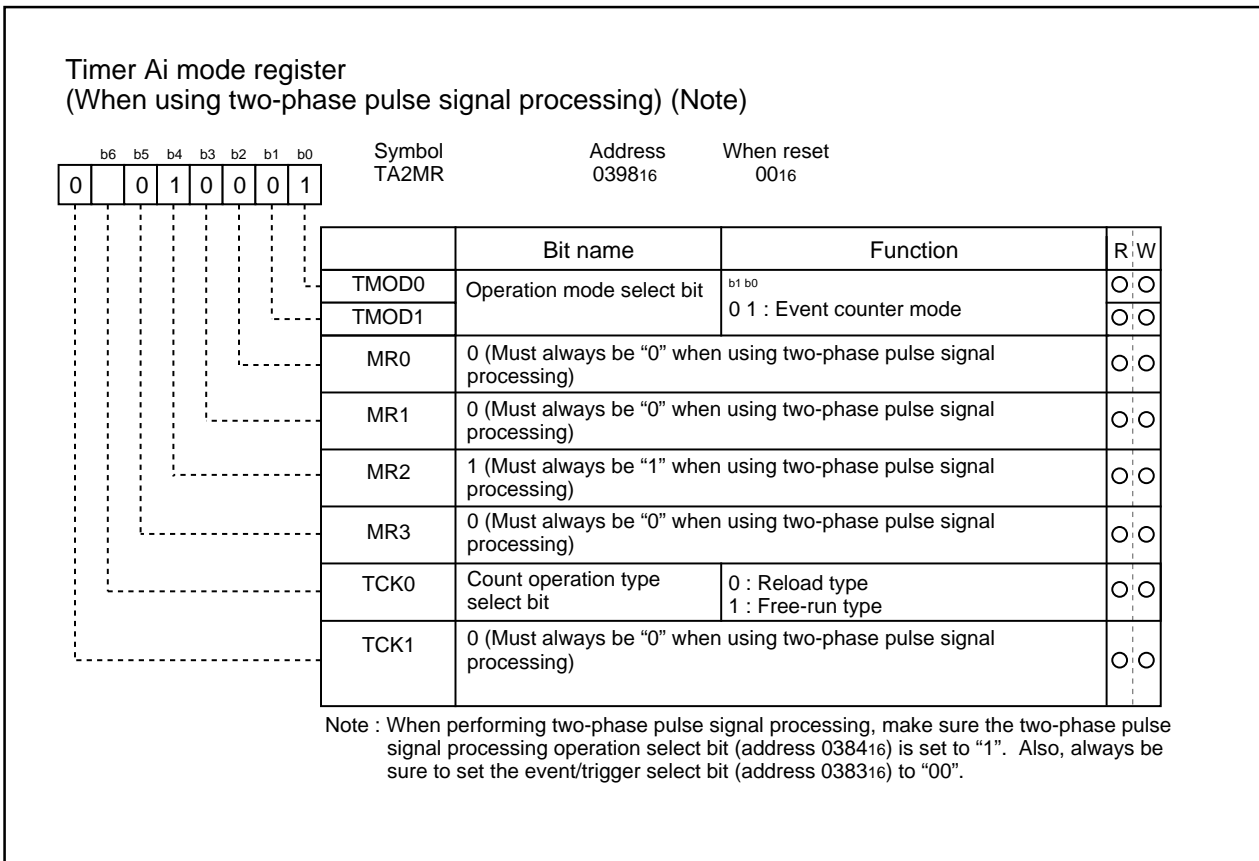

Figure 1.14.9. Timer Ai mode register in event counter mode

Timer A

(3) One-shot timer mode

In this mode, the timer operates only once. (See Table 1.14.4.) When a trigger occurs, the timer starts up and continues operating for a given period. Figure 1.14.10 shows the timer Ai mode register in one-shot timer mode.

Table 1.14.4. Timer specifications in one-shot timer mode

Item	Specification
Count source	f1, f8, f32, fc32
Count operation	<ul style="list-style-type: none"> The timer counts down When the count reaches 0000₁₆, the timer stops counting after reloading a new count If a trigger occurs when counting, the timer reloads a new count and restarts counting
Divide ratio	1/n n : Set value
Count start condition	<ul style="list-style-type: none"> An external trigger is input The timer overflows The one-shot start flag is set (= 1)
Count stop condition	<ul style="list-style-type: none"> A new count is reloaded after the count has reached 0000₁₆ The count start flag is reset (= 0)
Interrupt request generation timing	The count reaches 0000 ₁₆
TAiIN pin function	Programmable I/O port or trigger input
TAiOUT pin function	Programmable I/O port or pulse output
Read from timer	When timer Ai register is read, it indicates an indeterminate value
Write to timer	<ul style="list-style-type: none"> When counting stopped When a value is written to timer Ai register, it is written to both reload register and counter When counting in progress When a value is written to timer Ai register, it is written to only reload register (Transferred to counter at next reload time)

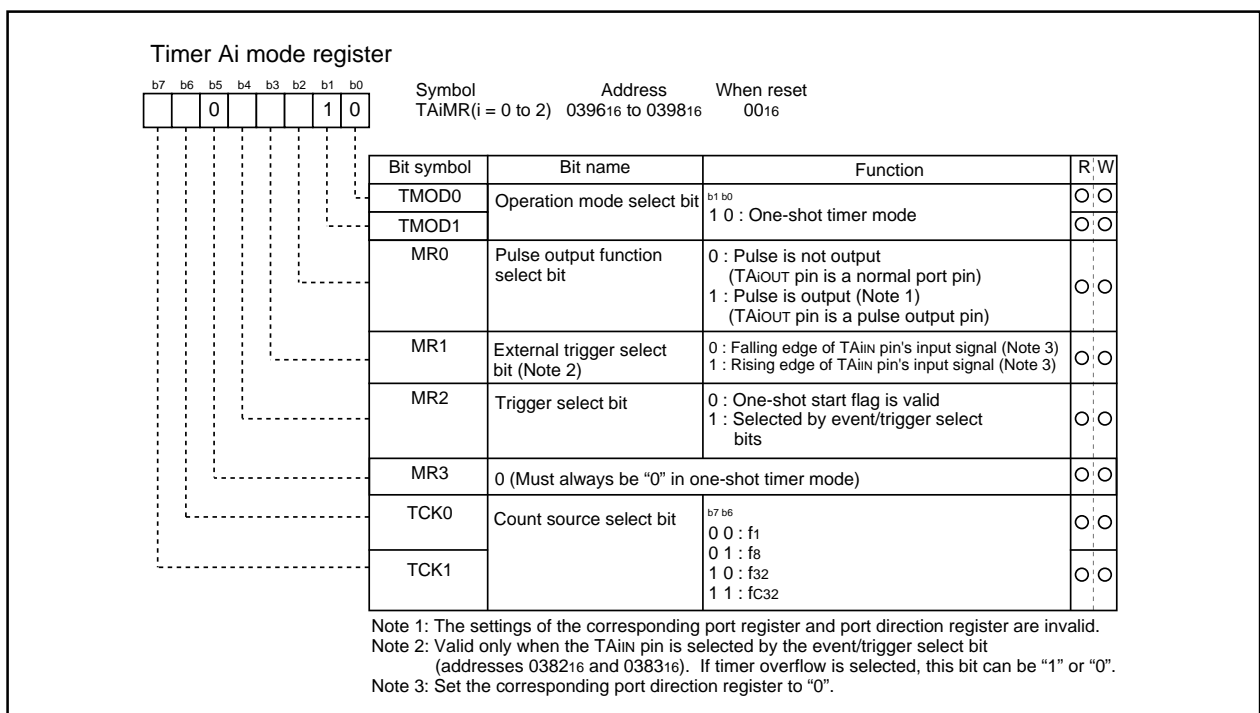

Figure 1.14.10. Timer Ai mode register in one-shot timer mode

Timer A

(4) Pulse width modulation (PWM) mode

In this mode, the timer outputs pulses of a given width in succession. (See Table 1.14.5.) In this mode, the counter functions as either a 16-bit pulse width modulator or an 8-bit pulse width modulator. Figure 1.14.11 shows the timer Ai mode register in pulse width modulation mode. Figure 1.14.12 shows the example of how a 16-bit pulse width modulator operates. Figure 1.14.13 shows the example of how an 8-bit pulse width modulator operates.

Table 1.14.5. Timer specifications in pulse width modulation mode

Item	Specification
Count source	f ₁ , f ₈ , f ₃₂ , f _{C32}
Count operation	<ul style="list-style-type: none"> The timer counts down (operating as an 8-bit or a 16-bit pulse width modulator) The timer reloads a new count at a rising edge of PWM pulse and continues counting The timer is not affected by a trigger that occurs when counting
16-bit PWM	<ul style="list-style-type: none"> High level width n / f_i n : Set value Cycle time $(2^{16}-1) / f_i$ fixed
8-bit PWM	<ul style="list-style-type: none"> High level width $n \times (m+1) / f_i$ n : values set to timer Ai register's high-order address Cycle time $(2^8-1) \times (m+1) / f_i$ m : values set to timer Ai register's low-order address
Count start condition	<ul style="list-style-type: none"> External trigger is input The timer overflows The count start flag is set (= 1)
Count stop condition	<ul style="list-style-type: none"> The count start flag is reset (= 0)
Interrupt request generation timing	PWM pulse goes "L"
TAiIN pin function	Programmable I/O port or trigger input
TAiOUT pin function	Pulse output
Read from timer	When timer Ai register is read, it indicates an indeterminate value
Write to timer	<ul style="list-style-type: none"> When counting stopped When a value is written to timer Ai register, it is written to both reload register and counter When counting in progress When a value is written to timer Ai register, it is written to only reload register (Transferred to counter at next reload time)

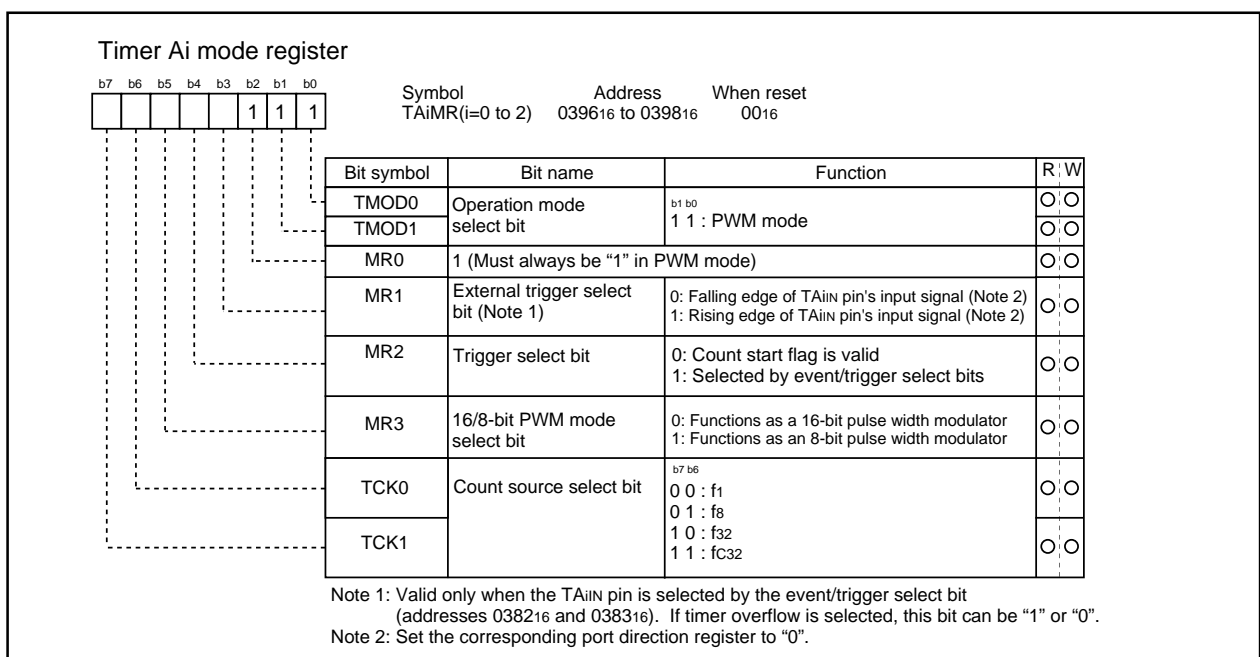
**Figure 1.14.11. Timer Ai mode register in pulse width modulation mode**

Timer A

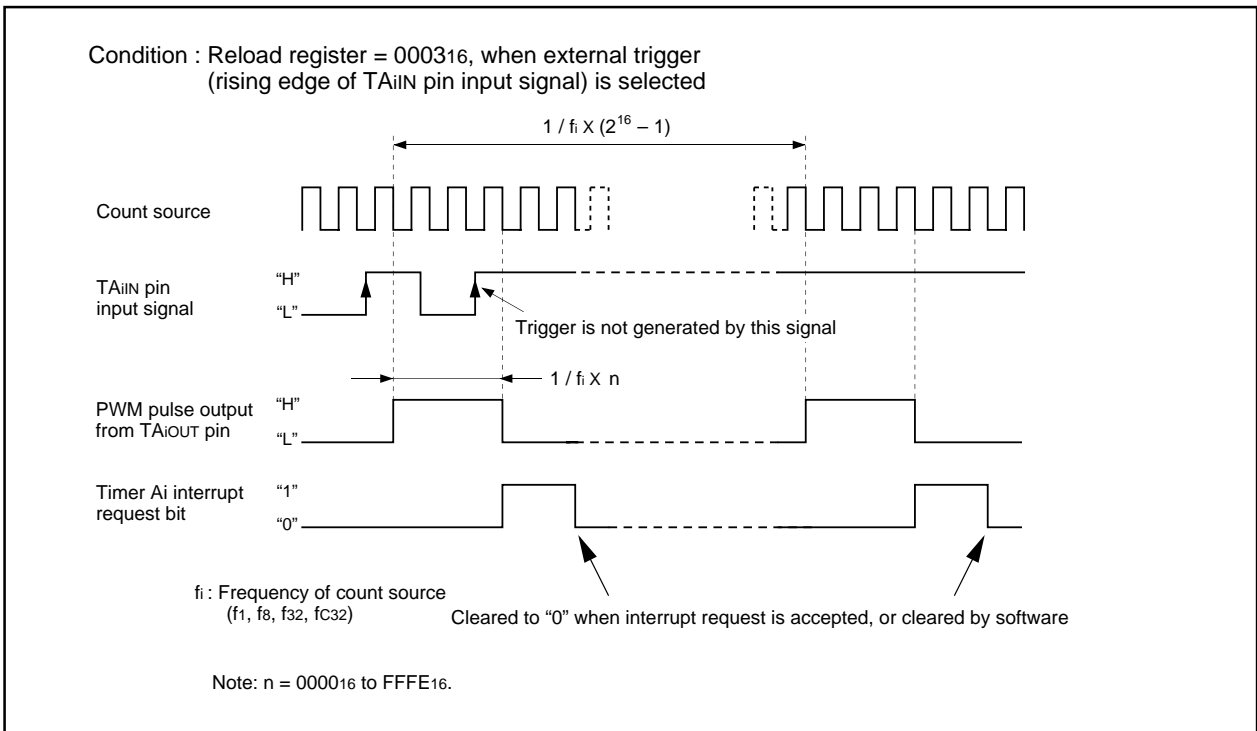

Figure 1.14.12. Example of how a 16-bit pulse width modulator operates

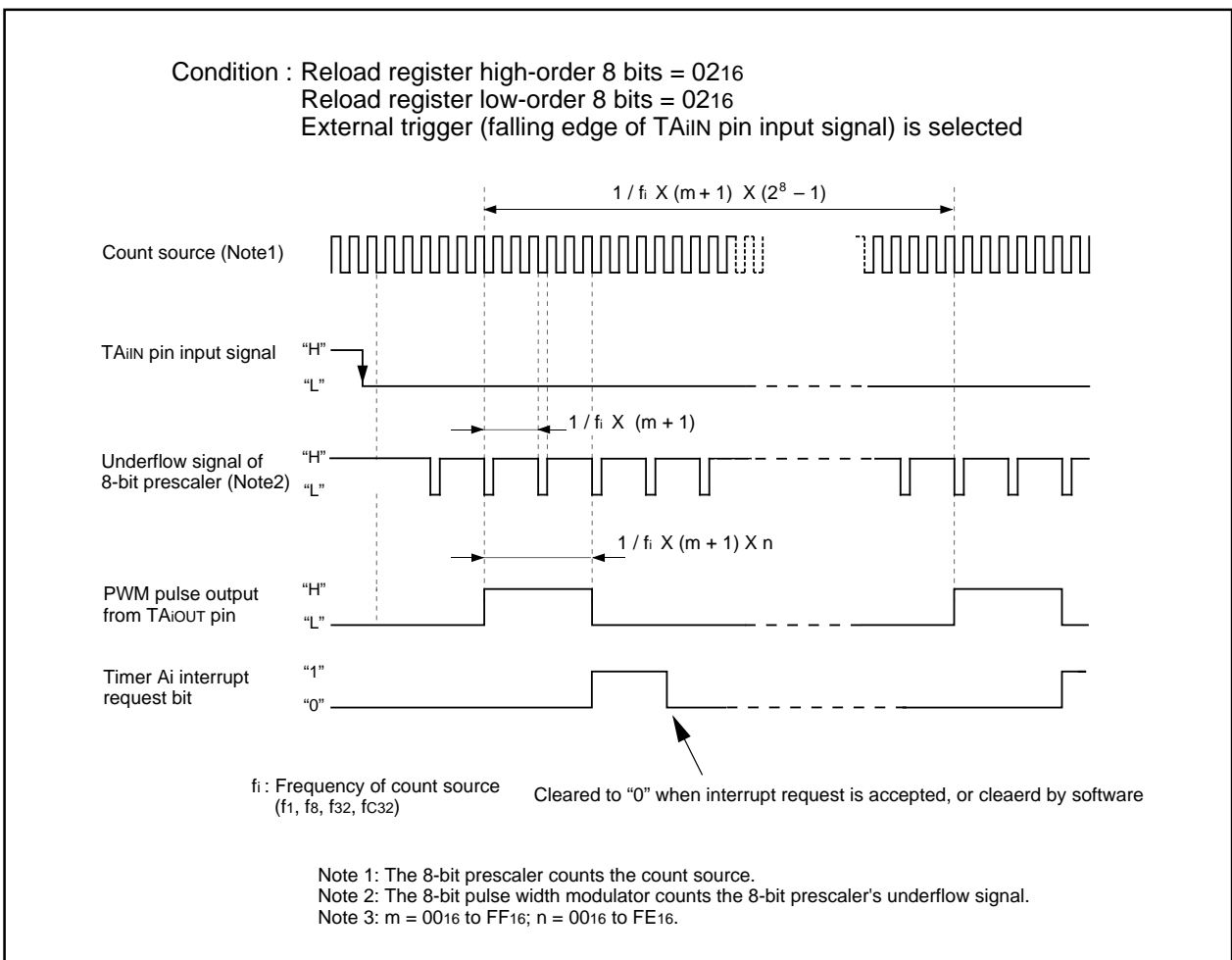

Figure 1.14.13. Example of how an 8-bit pulse width modulator operates

Timer B

Timer B

Figure 1.14.14 shows the block diagram of timer B. Figures 1.14.15 and 1.14.16 show the timer B-related registers.

Use the timer Bi mode register (i = 1, 2) bits 0 and 1 to choose the desired mode.

Timer B has three operation modes listed as follows:

- Timer mode: The timer counts an internal count source.
- Event counter mode: The timer counts pulses from an external source or a timer overflow.
- Pulse period/pulse width measuring mode: The timer measures an external signal's pulse period or pulse width.

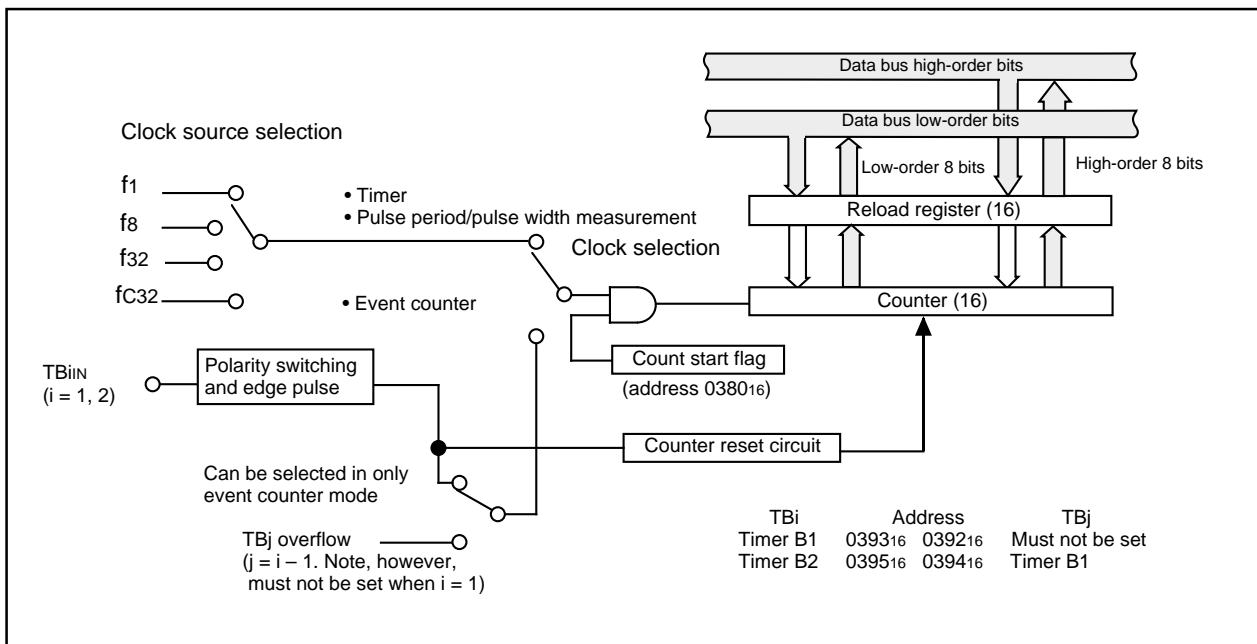

Figure 1.14.14. Block diagram of timer B

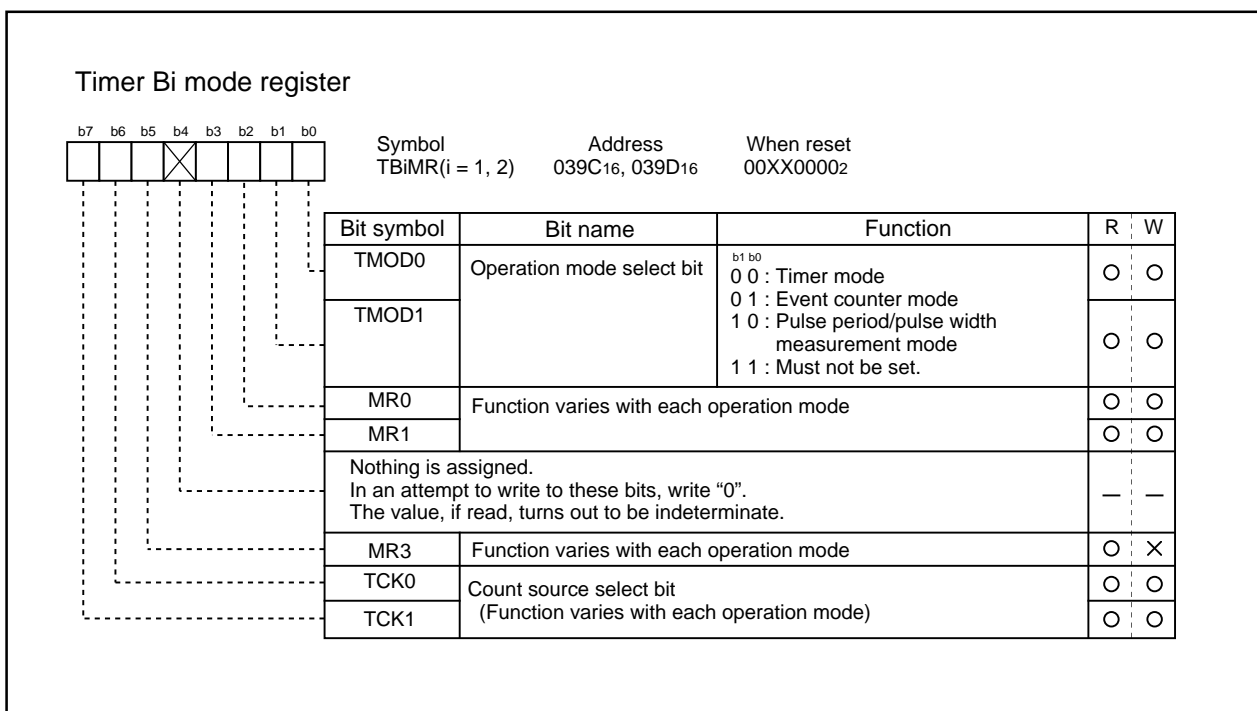

Figure 1.14.15. Timer B-related registers (1)

Timer B

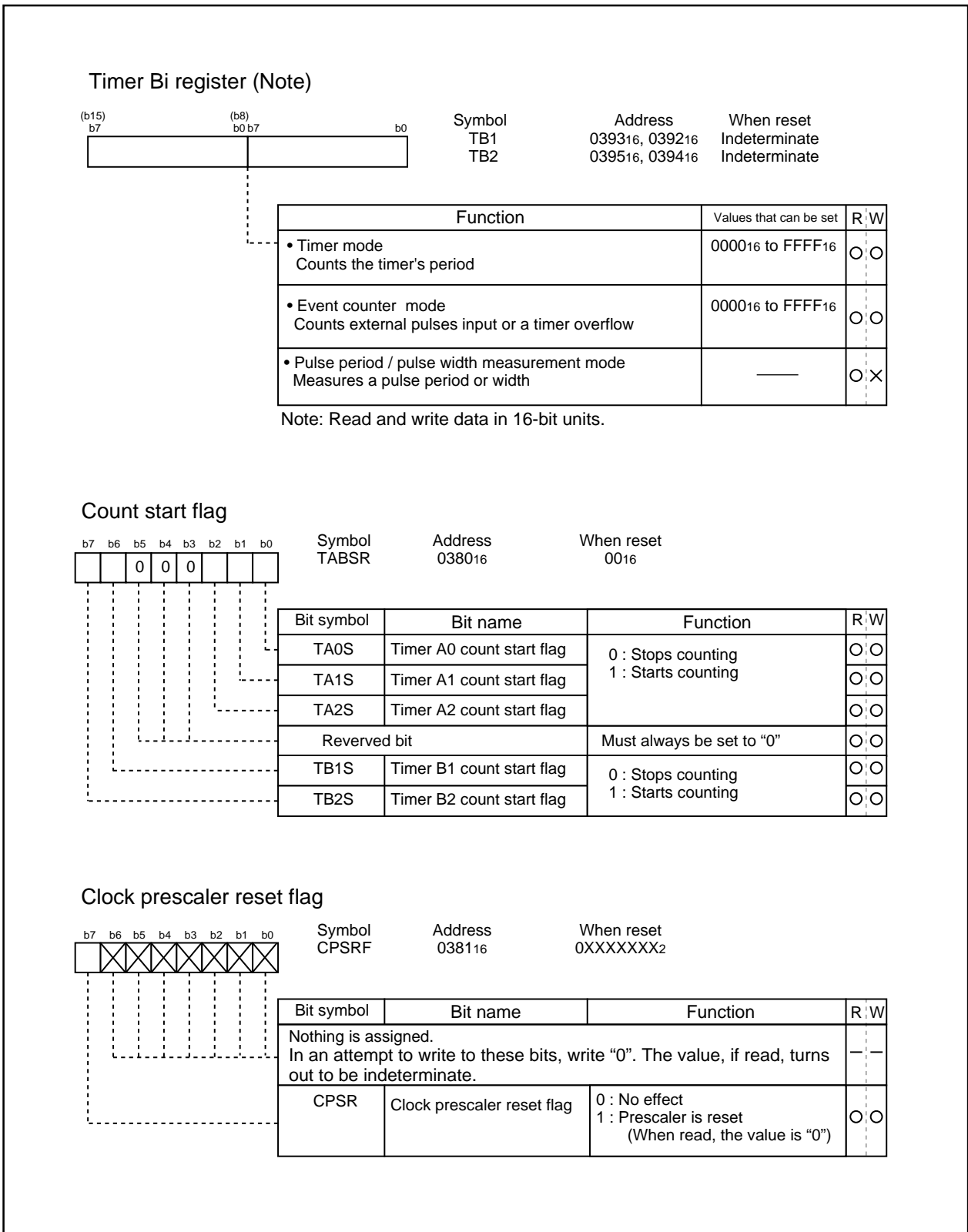

Figure 1.14.16. Timer B-related registers (2)

Timer B

(1) Timer mode

In this mode, the timer counts an internally generated count source. (See Table 1.14.6.) Figure 1.14.17 shows the timer Bi mode register in timer mode.

Table 1.14.6. Timer specifications in timer mode

Item	Specification
Count source	f1, f8, f32, fC32
Count operation	<ul style="list-style-type: none"> Counts down When the timer underflows, it reloads the reload register contents before continuing counting
Divide ratio	1/(n+1) n : Set value
Count start condition	Count start flag is set (= 1)
Count stop condition	Count start flag is reset (= 0)
Interrupt request generation timing	The timer underflows
TBiIN pin function	Programmable I/O port
Read from timer	Count value is read out by reading timer Bi register
Write to timer	<ul style="list-style-type: none"> When counting stopped When a value is written to timer Bi register, it is written to both reload register and counter When counting in progress When a value is written to timer Bi register, it is written to only reload register (Transferred to counter at next reload time)

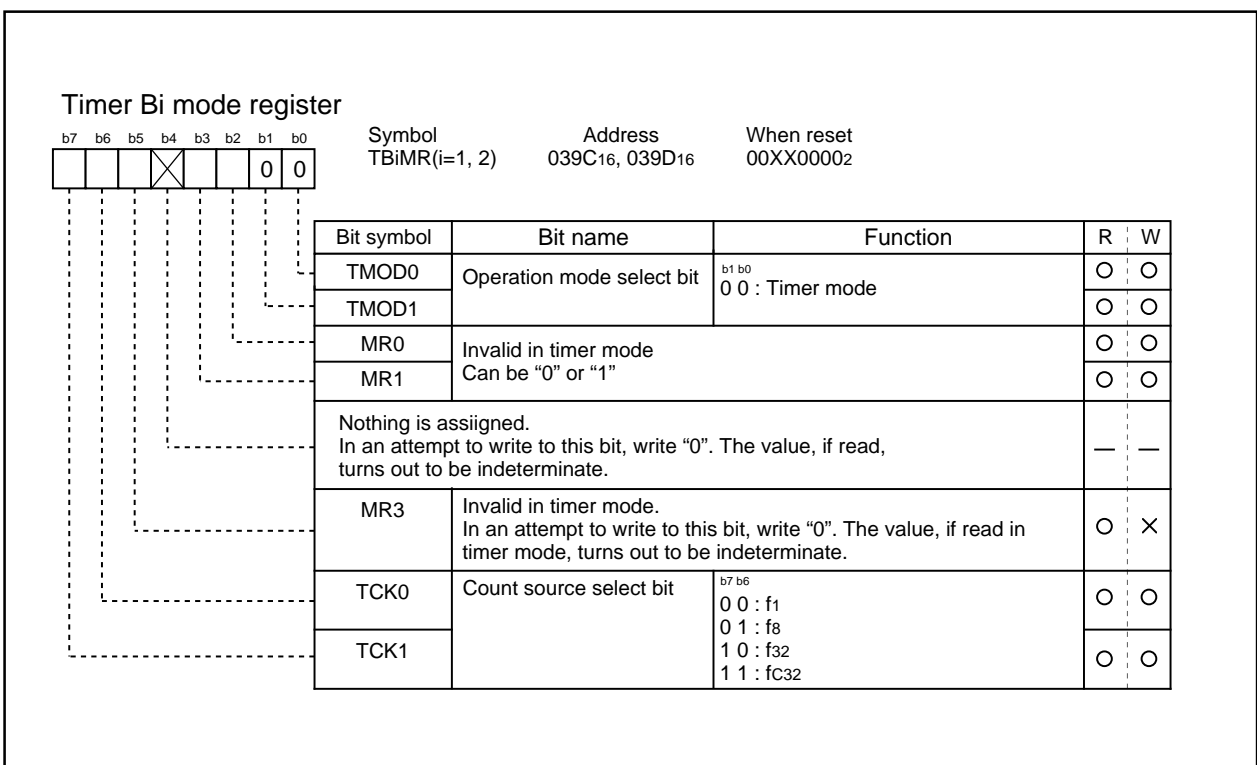

Figure 1.14.17. Timer Bi mode register in timer mode

Timer B

(2) Event counter mode

In this mode, the timer counts an external signal or an internal timer's overflow. (See Table 1.14.7.)

Figure 1.14.18 shows the timer Bi mode register in event counter mode.

Table 1.14.7. Timer specifications in event counter mode

Item	Specification
Count source	<ul style="list-style-type: none"> External signals input to TBiIN pin Effective edge of count source can be a rising edge, a falling edge, or falling and rising edges as selected by software
Count operation	<ul style="list-style-type: none"> Counts down When the timer underflows, it reloads the reload register contents before continuing counting
Divide ratio	$1/(n+1)$ n : Set value
Count start condition	Count start flag is set (= 1)
Count stop condition	Count start flag is reset (= 0)
Interrupt request generation timing	The timer underflows
TBiIN pin function	Count source input
Read from timer	Count value can be read out by reading timer Bi register
Write to timer	<ul style="list-style-type: none"> When counting stopped When a value is written to timer Bi register, it is written to both reload register and counter When counting in progress When a value is written to timer Bi register, it is written to only reload register (Transferred to counter at next reload time)

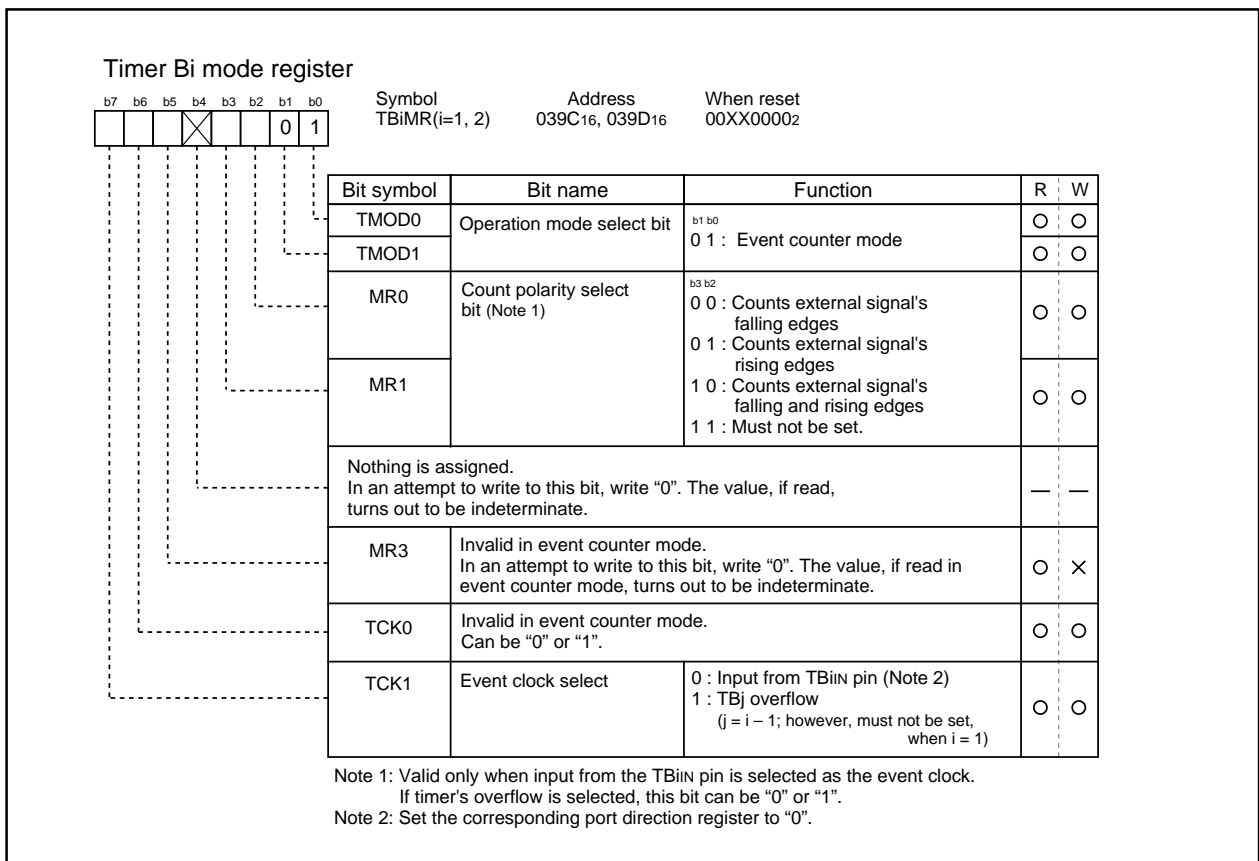

Figure 1.14.18. Timer Bi mode register in event counter mode

Timer B

(3) Pulse period/pulse width measurement mode

In this mode, the timer measures the pulse period or pulse width of an external signal. (See Table 1.14.8.) Figure 1.14.19 shows the timer Bi mode register in pulse period/pulse width measurement mode. Figure 1.14.20 shows the operation timing when measuring a pulse period. Figure 1.14.21 shows the operation timing when measuring a pulse width.

Table 1.14.8. Timer specifications in pulse period/pulse width measurement mode

Item	Specification
Count source	f1, f8, f32, fc32
Count operation	<ul style="list-style-type: none"> • Up count • Counter value "0000₁₆" is transferred to reload register at measurement pulse's effective edge and the timer continues counting
Count start condition	Count start flag is set (= 1)
Count stop condition	Count start flag is reset (= 0)
Interrupt request generation timing	<ul style="list-style-type: none"> • When measurement pulse's effective edge is input (Note 1) • When an overflow occurs. (Simultaneously, the timer Bi overflow flag changes to "1". Assume that the count start flag condition is "1" and then the timer Bi overflow flag becomes "1". If the timer Bi mode register has a write access after next count cycle of the timer from the above condition, the timer Bi overflow flag becomes "0".)
TBiIN pin function	Measurement pulse input
Read from timer	When timer Bi register is read, it indicates the reload register's content (measurement result) (Note 2)
Write to timer	Cannot be written to

Note 1: An interrupt request is not generated when the first effective edge is input after the timer has started counting.
Note 2: The value read out from the timer Bi register is indeterminate until the second effective edge is input after the timer has started counting.

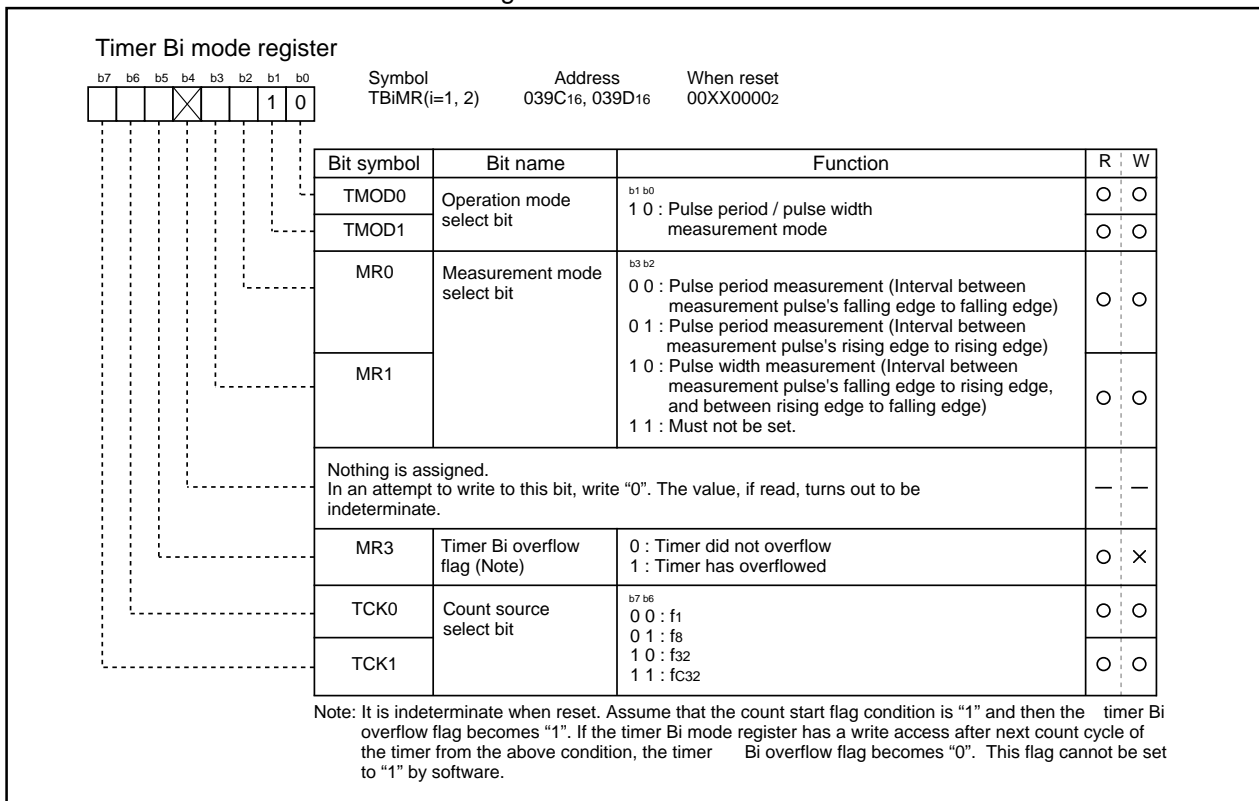

Figure 1.14.19. Timer Bi mode register in pulse period/pulse width measurement mode

Timer B

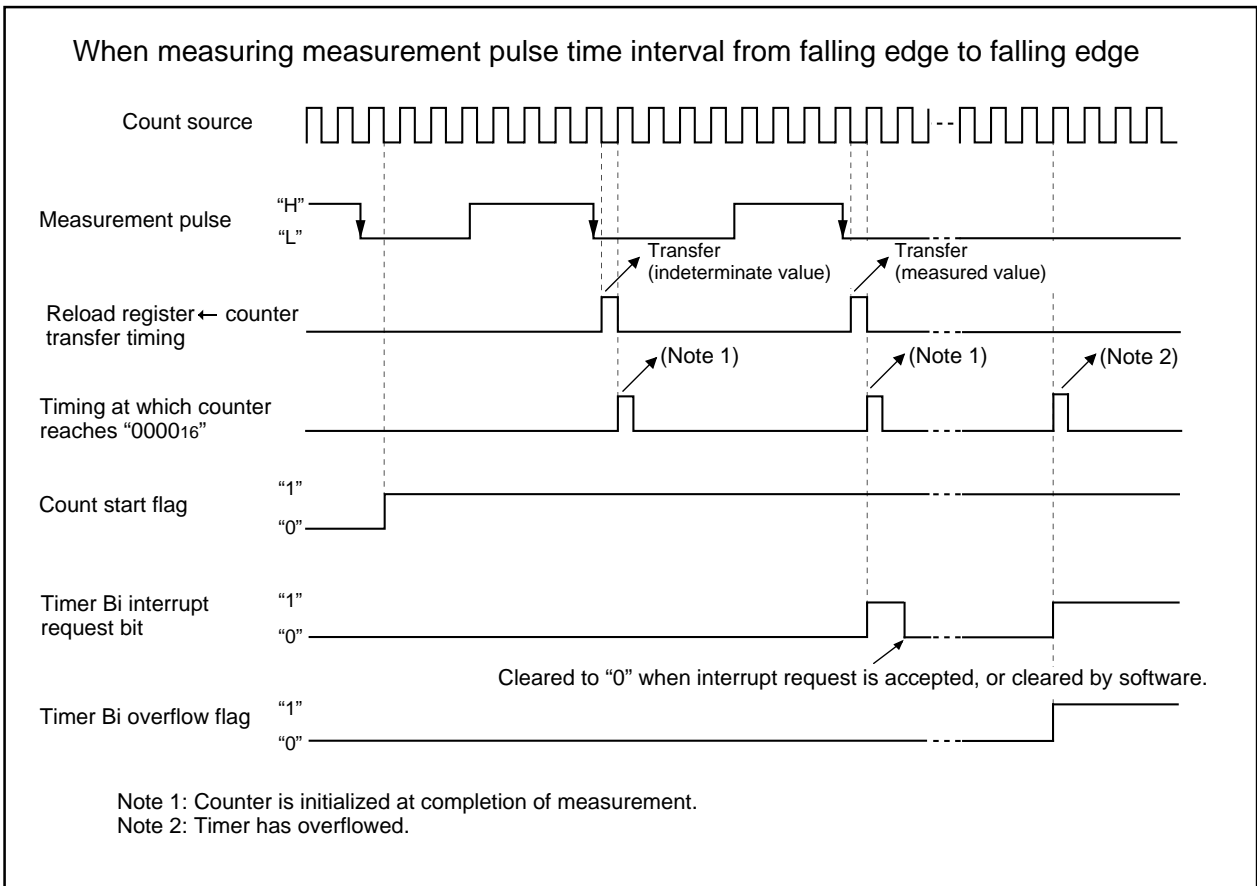

Figure 1.14.20. Operation timing when measuring a pulse period

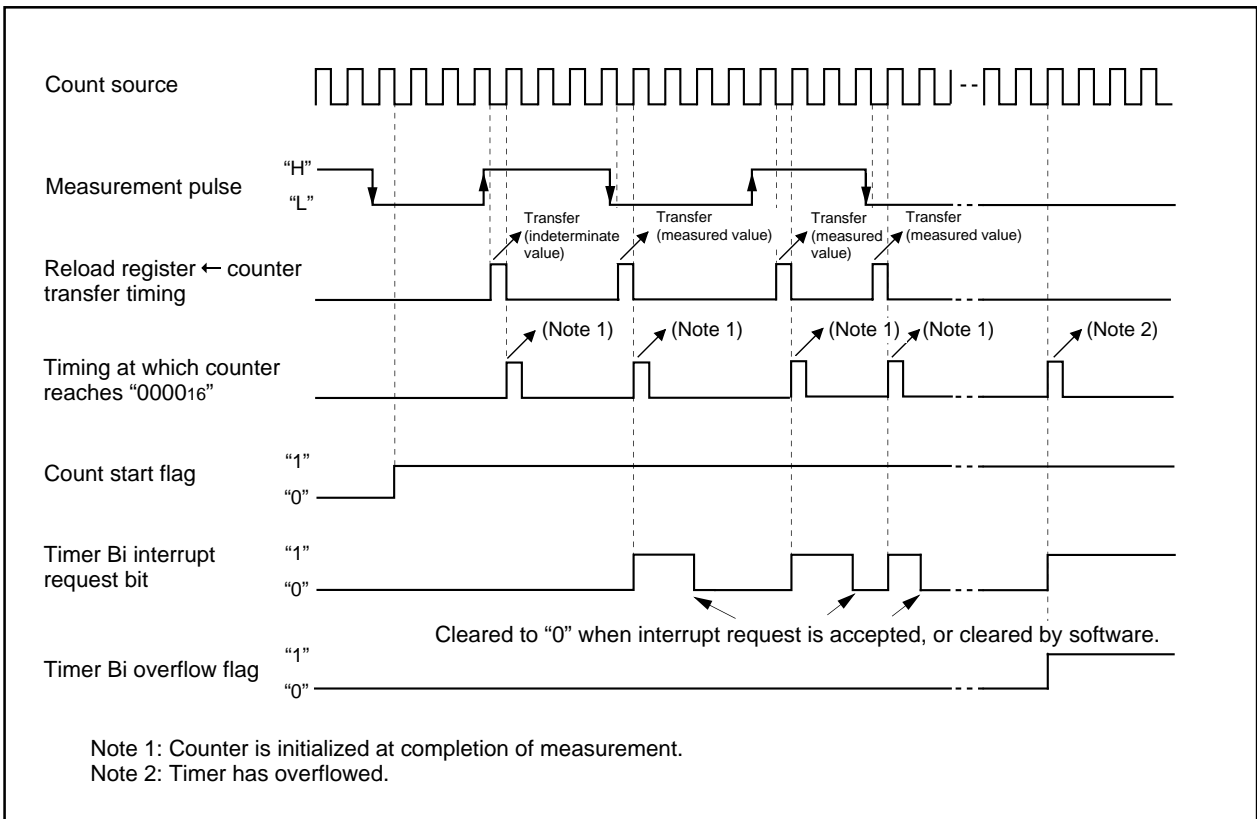

Figure 1.14.21. Operation timing when measuring a pulse width

Serial I/O

Serial I/O is configured as three channels: UART0, UART1, UART2.

UART0, UART1 and UART2 each have an exclusive timer to generate a transfer clock, so they operate independently of each other.

Figure 1.16.1 shows the block diagram of UART0, UART1 and UART2. Figures 1.16.2 and 1.16.3 show the block diagram of the transmit/receive unit.

UARTi (i = 0 to 2) has two operation modes: a clock synchronous serial I/O mode and a clock asynchronous serial I/O mode (UART mode). The contents of the serial I/O mode select bits (bits 0 to 2 at addresses 03A0₁₆, 03A8₁₆ and 0378₁₆) determine whether UARTi is used as a clock synchronous serial I/O or as a UART. Although a few functions are different, UART0, UART1 and UART2 have almost the same functions. UART2, in particular, is used for the SIM interface with some extra settings added in clock-asynchronous serial I/O mode (Note). It also has the bus collision detection function that generates an interrupt request if the TxD pin and the RxD pin are different in level.

Table 1.16.1 shows the comparison of functions of UART0 through UART2, and Figures 1.16.4 to 1.16.9 show the registers related to UARTi.

Note: SIM : Subscriber Identity Module

Table 1.16.1. Comparison of functions of UART0 through UART2

Function	UART0	UART1	UART2
CLK polarity selection	Possible (Note 1)	Possible (Note 1)	Possible (Note 1)
LSB first / MSB first selection	Possible (Note 1)	Possible (Note 1)	Possible (Note 2)
Continuous receive mode selection	Possible (Note 1)	Possible (Note 1)	Possible (Note 1)
Transfer clock output from multiple pins selection	Impossible	Possible (Note 1)	Impossible
Serial data logic switch	Impossible	Impossible	Possible (Note 4)
Sleep mode selection	Possible (Note 3)	Possible (Note 3)	Impossible
TxD, RxD I/O polarity switch	Impossible	Impossible	Possible
TxD, RxD port output format	CMOS output	CMOS output	N-channel open-drain output
Parity error signal output	Impossible	Impossible	Possible (Note 4)
Bus collision detection	Impossible	Impossible	Possible

Note 1: Only when clock synchronous serial I/O mode.

Note 2: Only when clock synchronous serial I/O mode and 8-bit UART mode.

Note 3: Only when UART mode.

Note 4: Using for SIM interface.

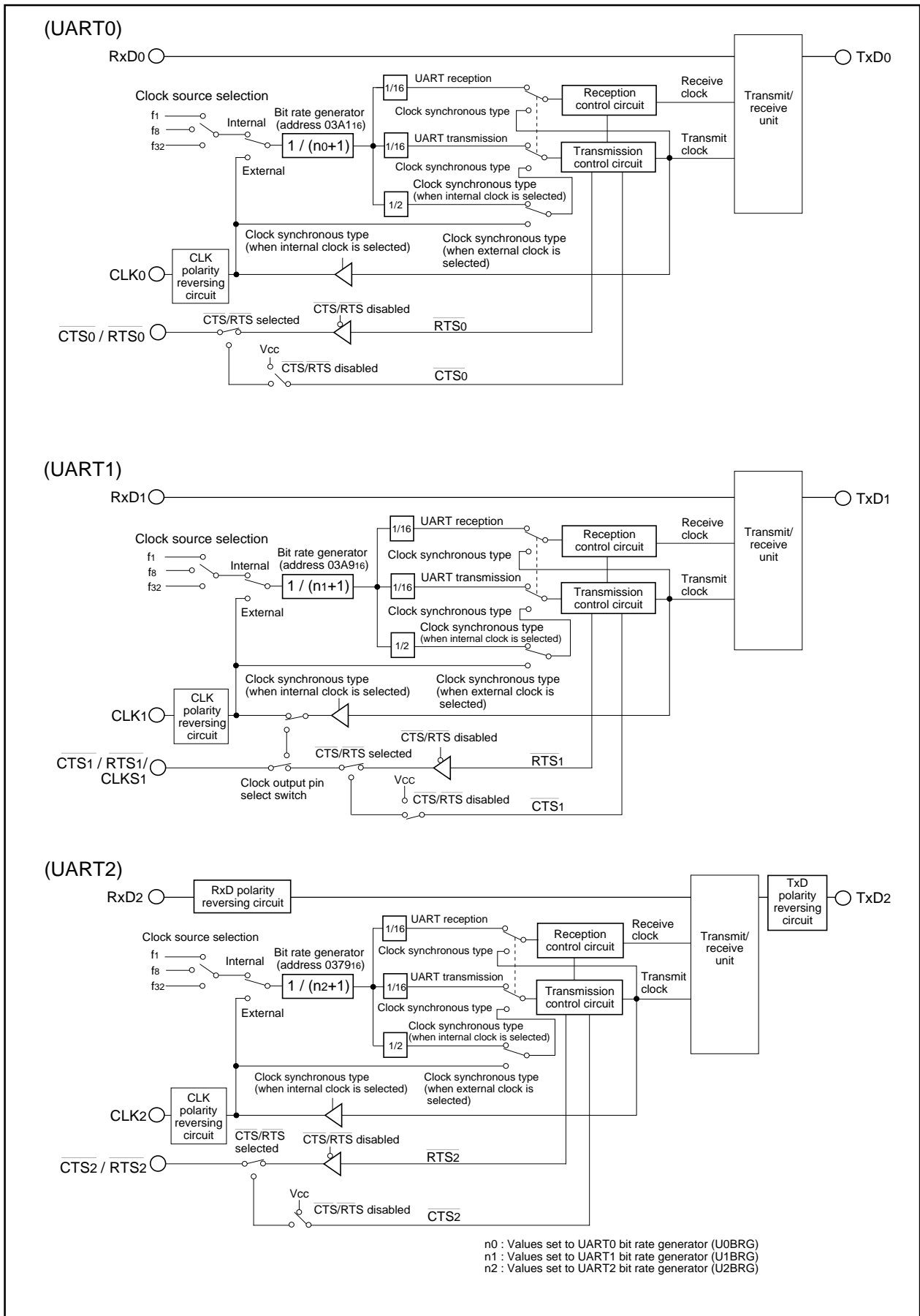

Figure 1.16.1. Block diagram of UARTi (i = 0 to 2)

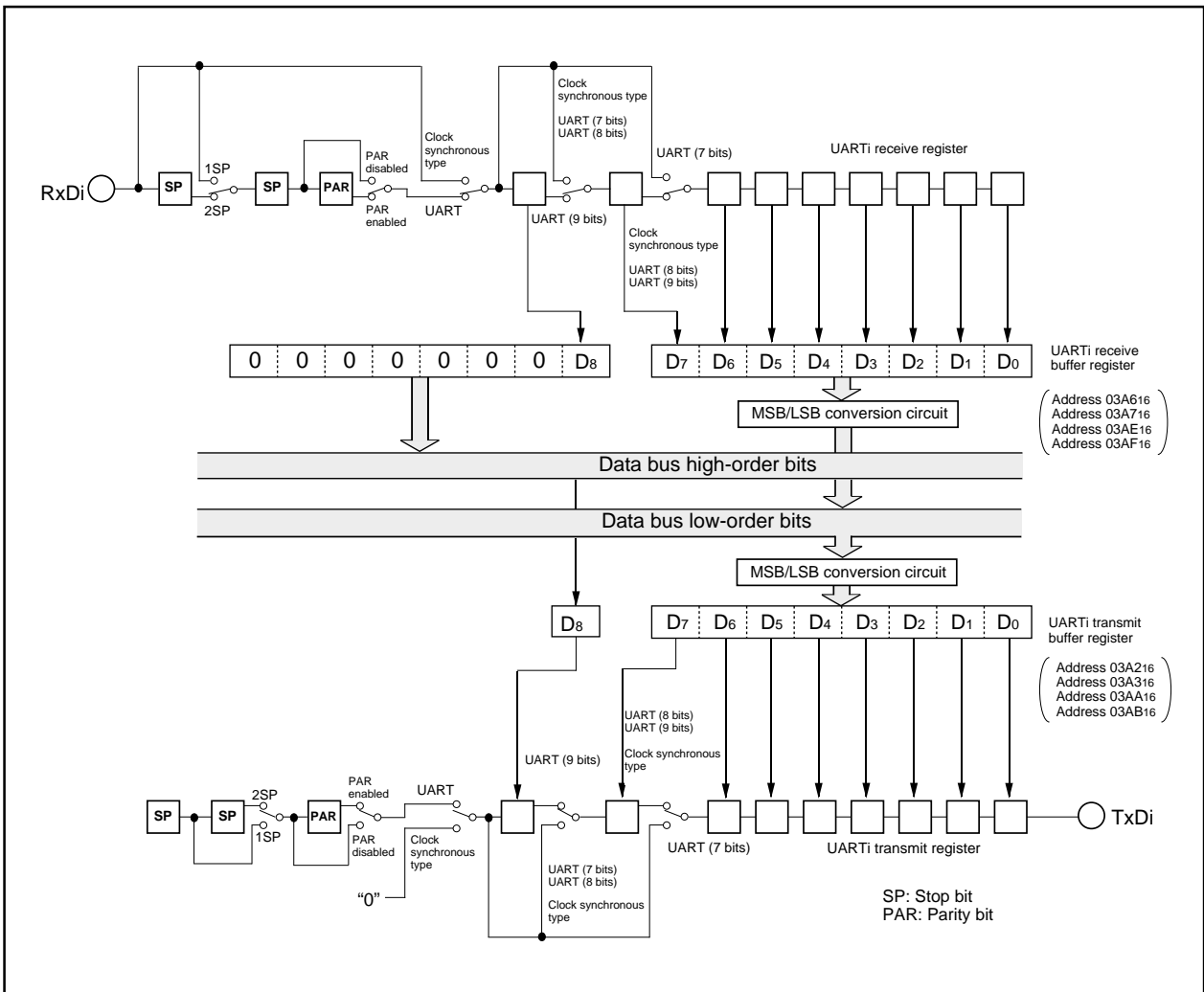

Figure 1.16.2. Block diagram of UARTi (i = 0, 1) transmit/receive unit

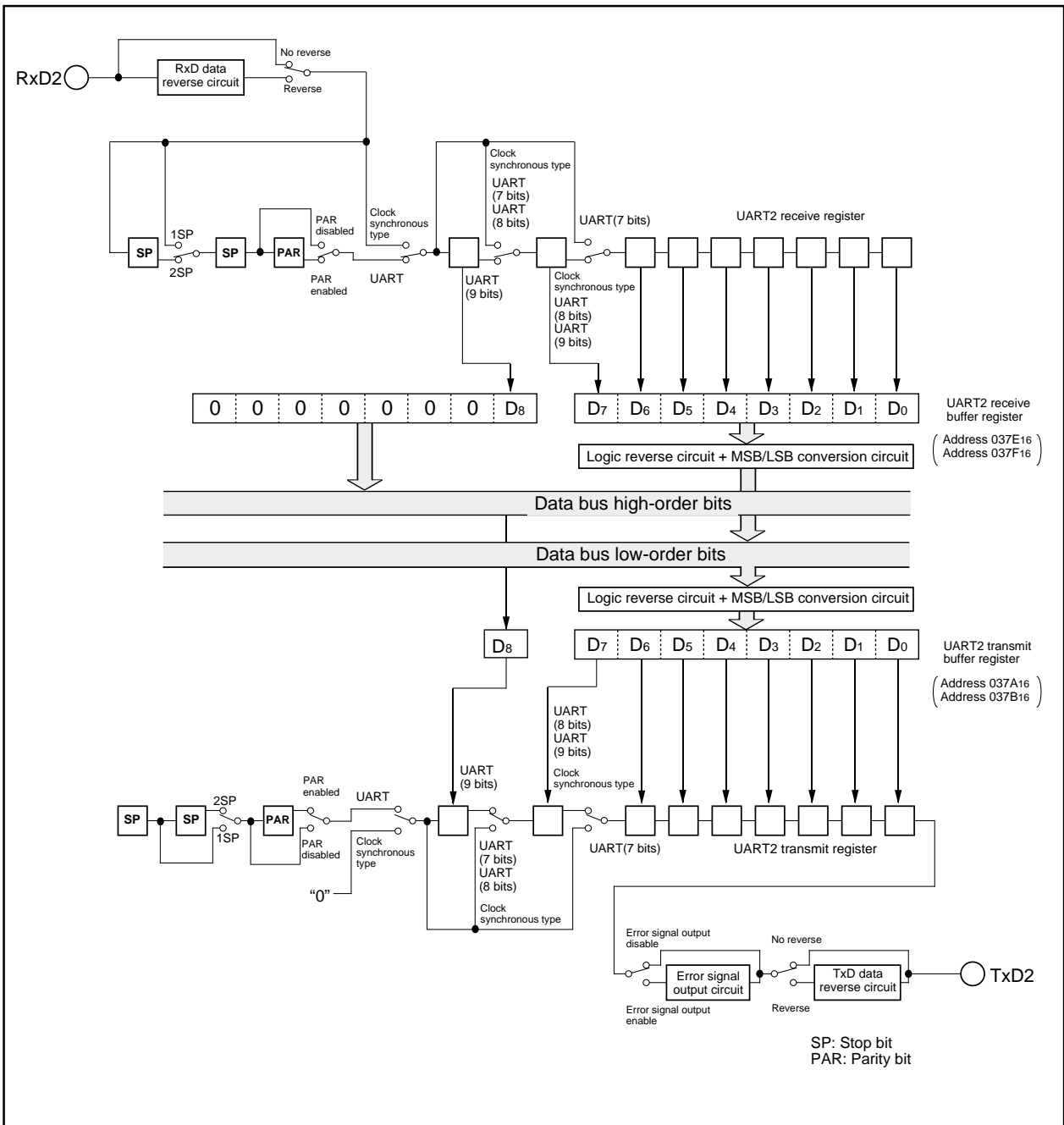

Figure 1.16.3. Block diagram of UART2 transmit/receive unit

Serial I/O

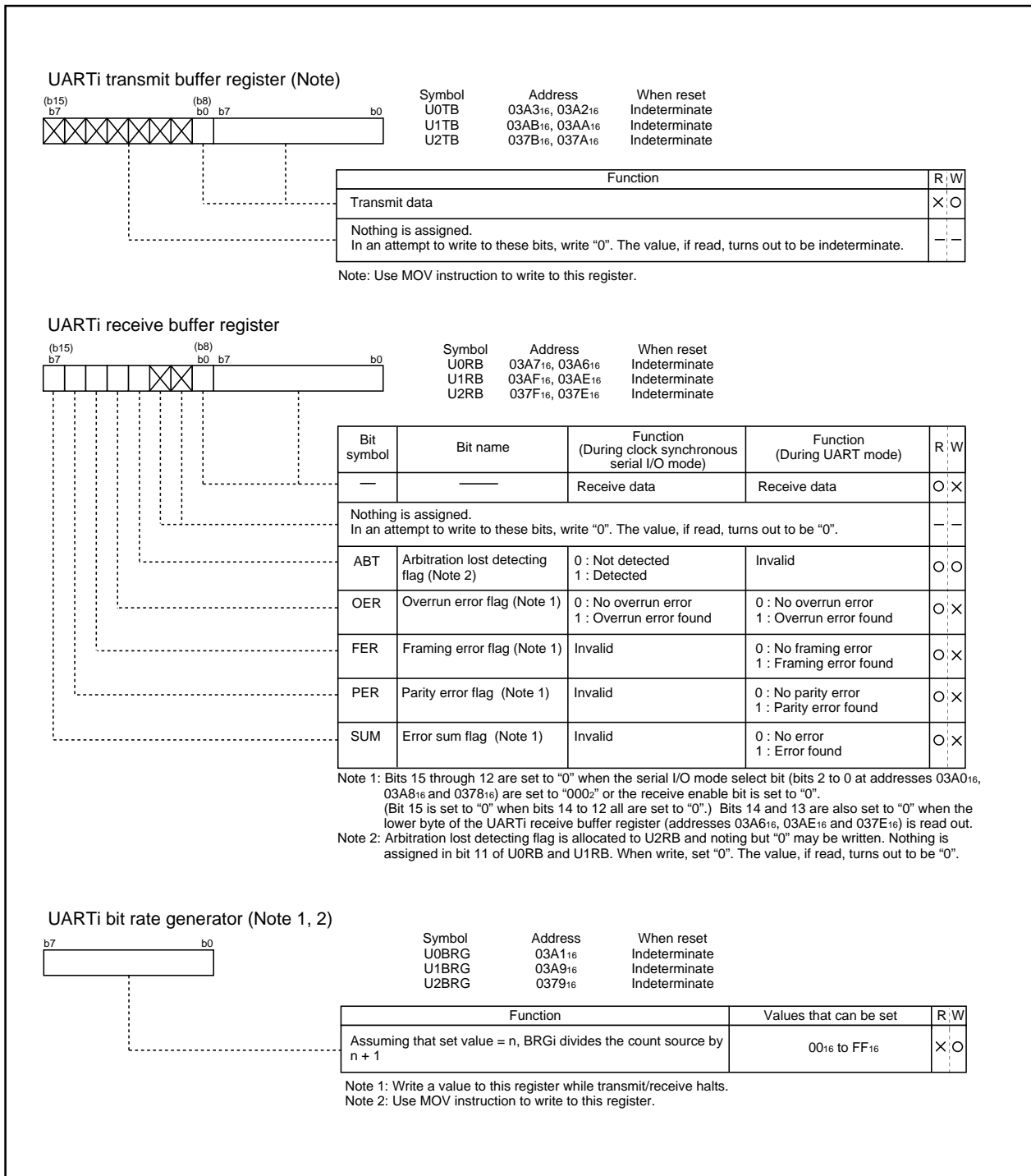

Figure 1.16.4. Serial I/O-related registers (1)

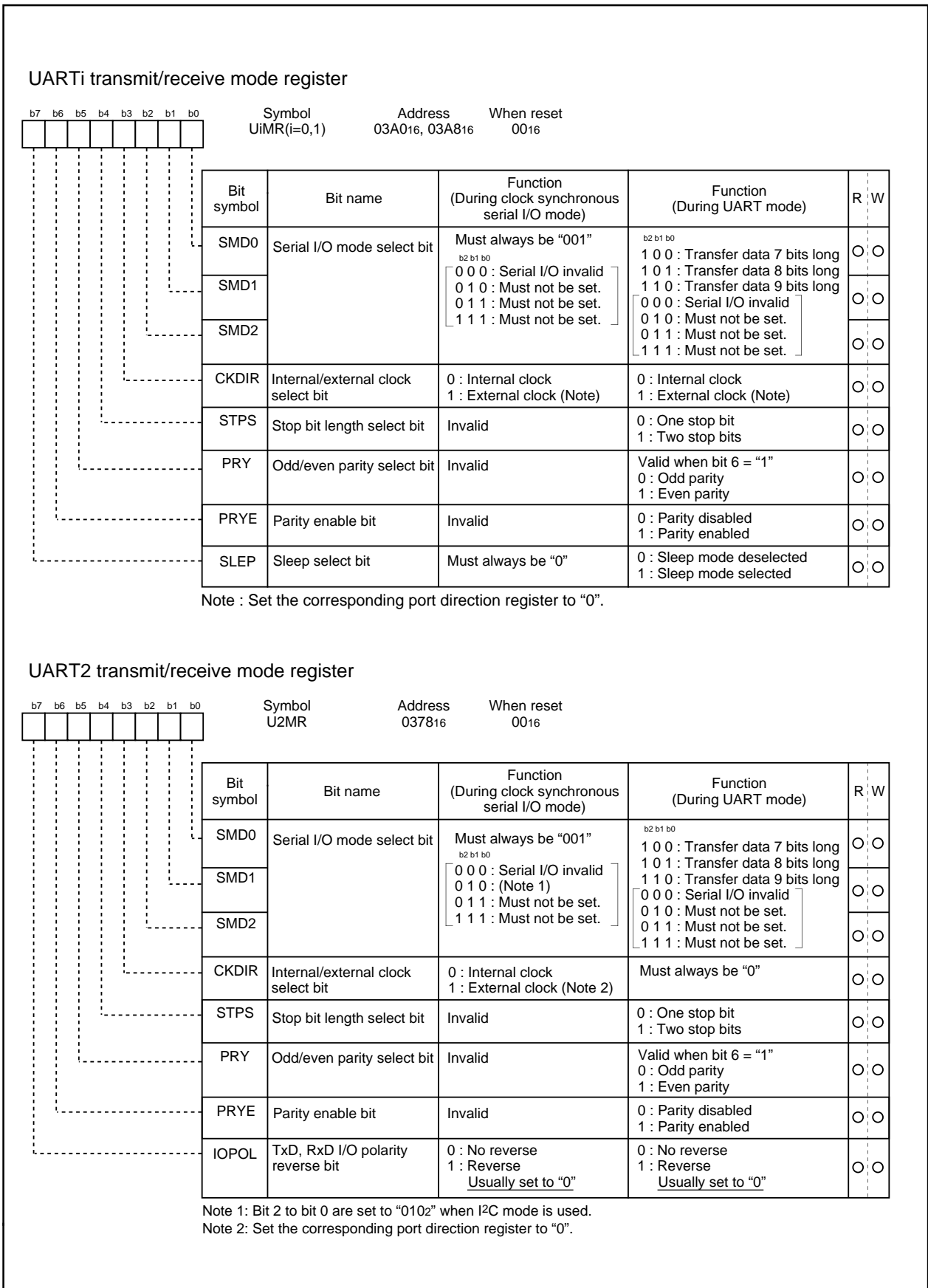

Figure 1.16.5. Serial I/O-related registers (2)

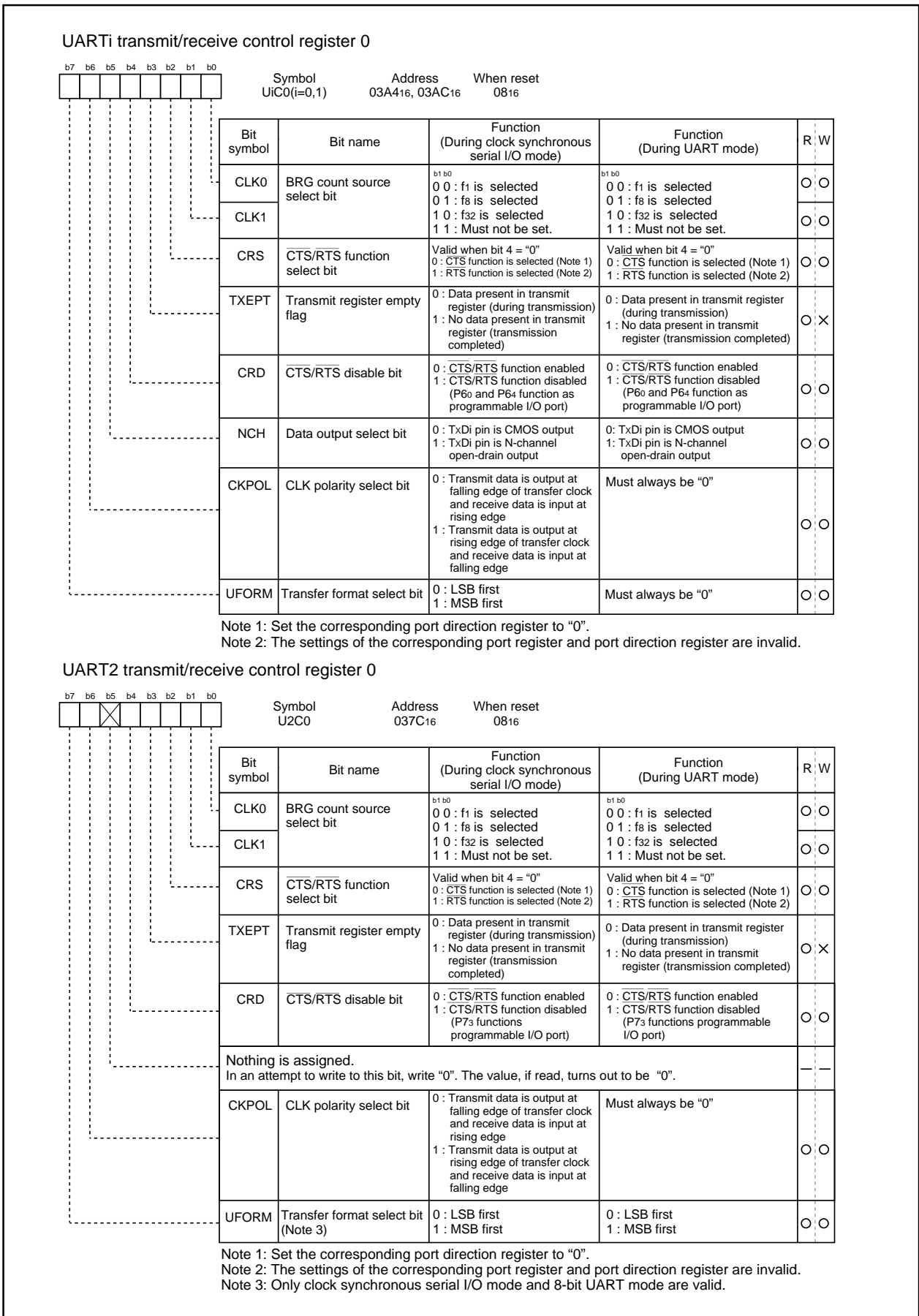

Figure 1.16.6. Serial I/O-related registers (3)

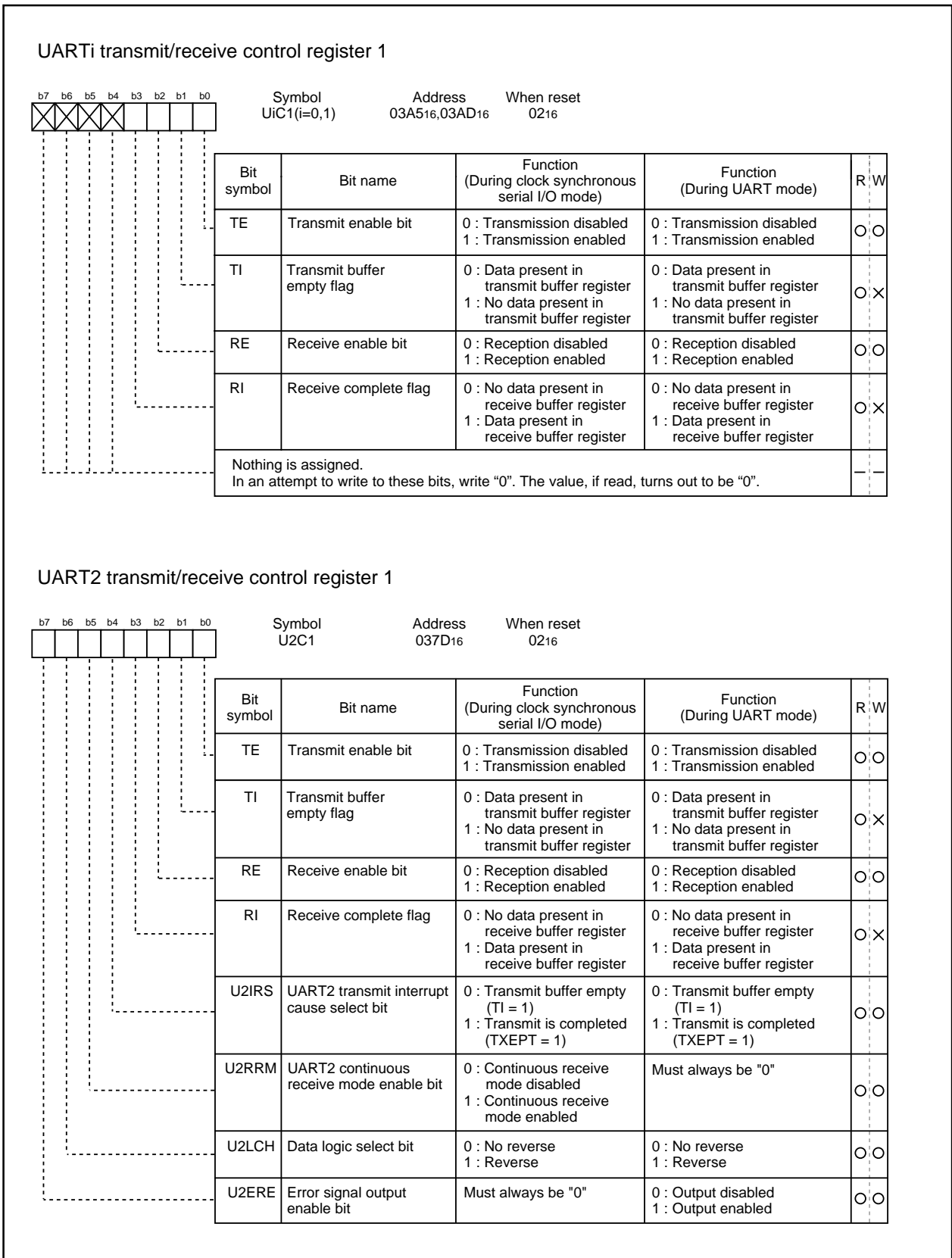

Figure 1.16.7. Serial I/O-related registers (4)

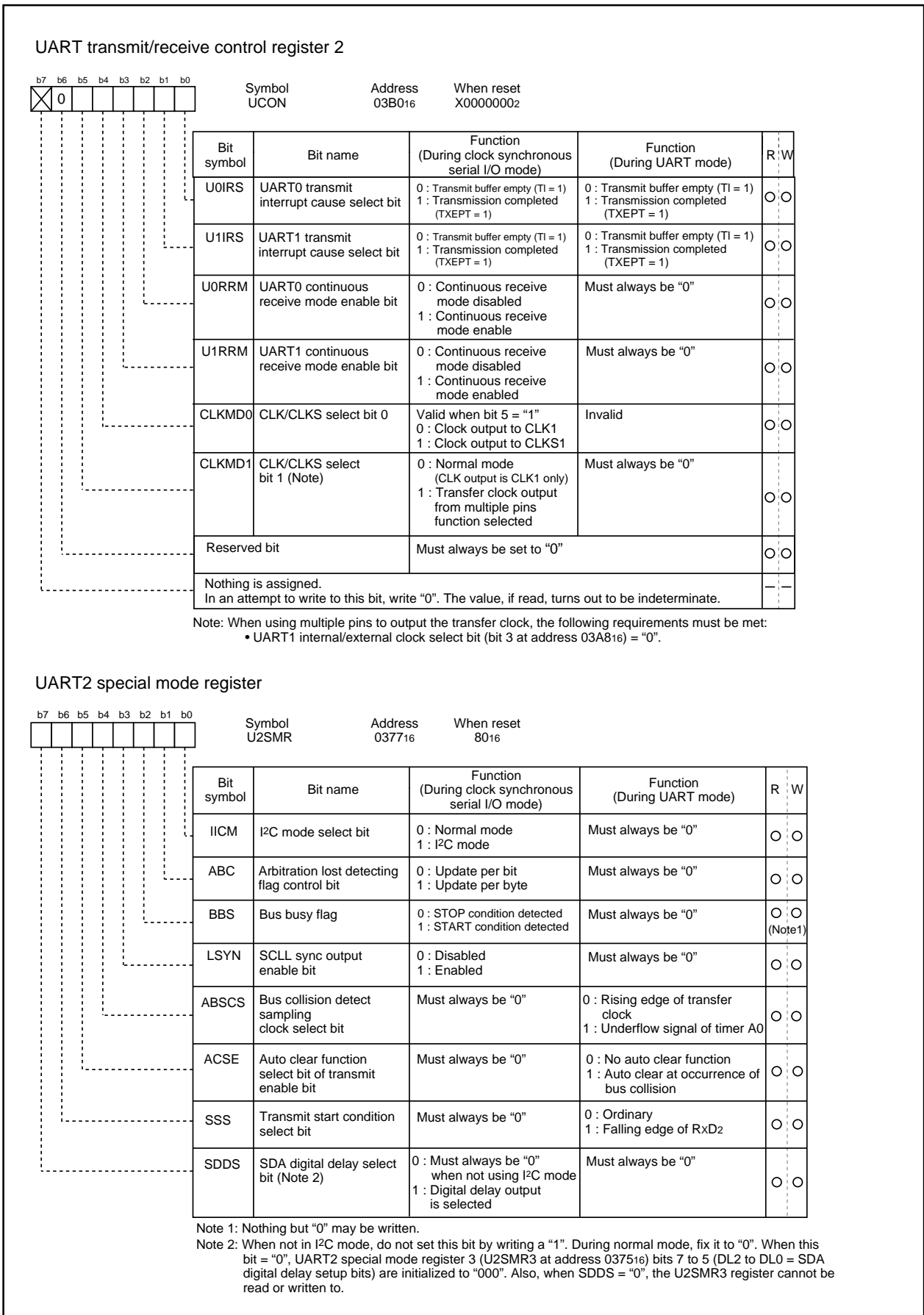

Figure 1.16.8. Serial I/O-related registers (5)

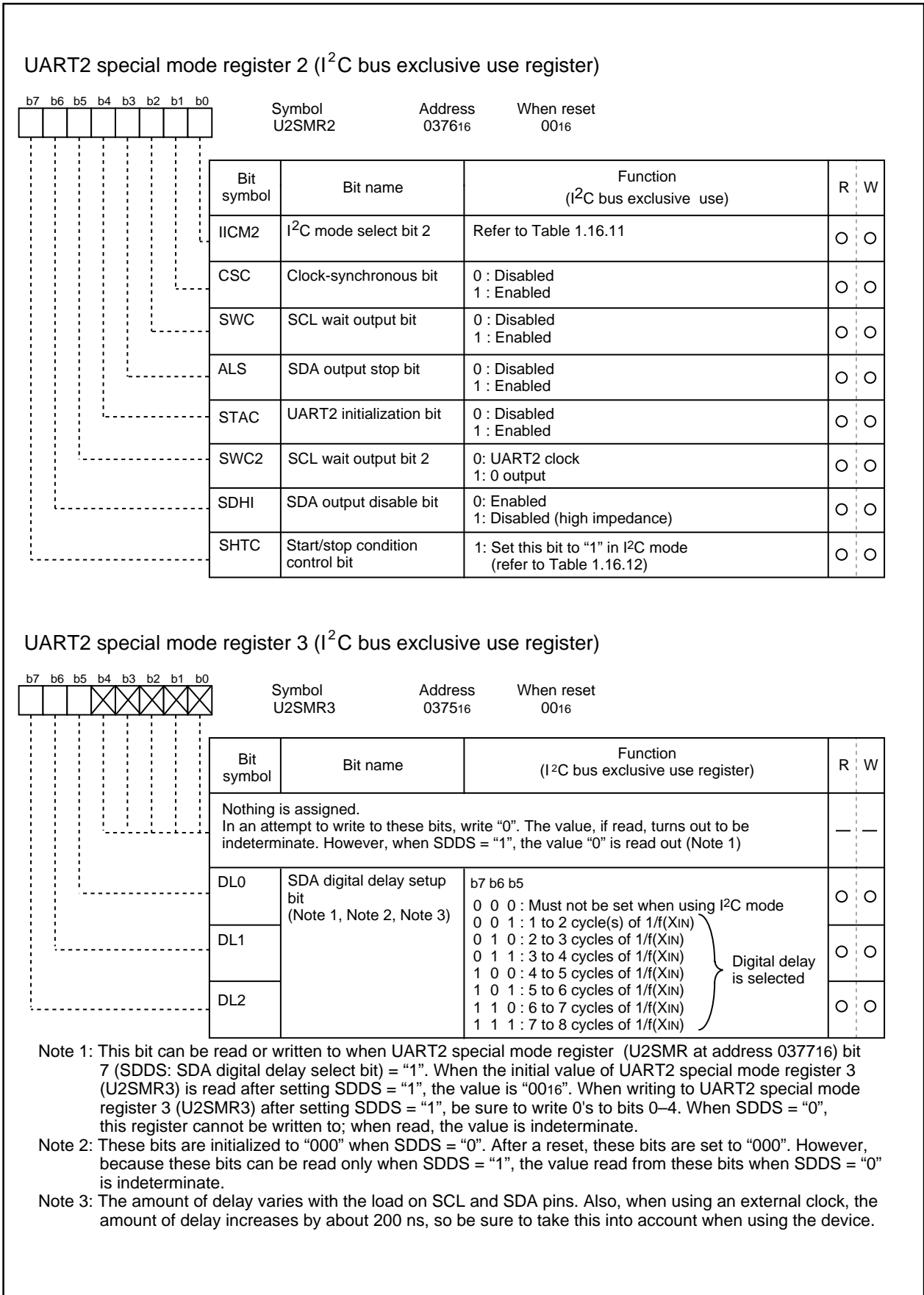

Figure 1.16.9. Serial I/O-related registers (6)

Clock synchronous serial I/O mode

(1) Clock synchronous serial I/O mode

The clock synchronous serial I/O mode uses a transfer clock to transmit and receive data. Tables 1.16.2 and 1.16.3 list the specifications of the clock synchronous serial I/O mode. Figure 1.16.10 shows the UART_i transmit/receive mode register.

Table 1.16.2. Specifications of clock synchronous serial I/O mode (1)

Item	Specification
Transfer data format	<ul style="list-style-type: none"> Transfer data length: 8 bits
Transfer clock	<ul style="list-style-type: none"> When internal clock is selected (bit 3 at addresses 03A0₁₆, 03A8₁₆, 0378₁₆ = "0") : $f_i / 2(n+1)$ (Note 1) $f_i = f_1, f_8, f_{32}$ When external clock is selected (bit 3 at addresses 03A0₁₆, 03A8₁₆, 0378₁₆ = "1") : Input from CLK_i pin
Transmission/reception control	<ul style="list-style-type: none"> CTS function, $\overline{\text{RTS}}$ function, CTS and RTS function invalid: selectable
Transmission start condition	<ul style="list-style-type: none"> To start transmission, the following requirements must be met: <ul style="list-style-type: none"> Transmit enable bit (bit 0 at addresses 03A5₁₆, 03AD₁₆, 037D₁₆) = "1" Transmit buffer empty flag (bit 1 at addresses 03A5₁₆, 03AD₁₆, 037D₁₆) = "0" When $\overline{\text{CTS}}$ function selected, $\overline{\text{CTS}}$ input level = "L" Furthermore, if external clock is selected, the following requirements must also be met: <ul style="list-style-type: none"> CLK_i polarity select bit (bit 6 at addresses 03A4₁₆, 03AC₁₆, 037C₁₆) = "0": CLK_i input level = "H" CLK_i polarity select bit (bit 6 at addresses 03A4₁₆, 03AC₁₆, 037C₁₆) = "1": CLK_i input level = "L"
Reception start condition	<ul style="list-style-type: none"> To start reception, the following requirements must be met: <ul style="list-style-type: none"> Receive enable bit (bit 2 at addresses 03A5₁₆, 03AD₁₆, 037D₁₆) = "1" Transmit enable bit (bit 0 at addresses 03A5₁₆, 03AD₁₆, 037D₁₆) = "1" Transmit buffer empty flag (bit 1 at addresses 03A5₁₆, 03AD₁₆, 037D₁₆) = "0" Furthermore, if external clock is selected, the following requirements must also be met: <ul style="list-style-type: none"> CLK_i polarity select bit (bit 6 at addresses 03A4₁₆, 03AC₁₆, 037C₁₆) = "0": CLK_i input level = "H" CLK_i polarity select bit (bit 6 at addresses 03A4₁₆, 03AC₁₆, 037C₁₆) = "1": CLK_i input level = "L"
Interrupt request generation timing	<ul style="list-style-type: none"> When transmitting <ul style="list-style-type: none"> Transmit interrupt cause select bit (bits 0, 1 at address 03B0₁₆, bit 4 at address 037D₁₆) = "0": Interrupts requested when data transfer from UART_i transfer buffer register to UART_i transmit register is completed Transmit interrupt cause select bit (bits 0, 1 at address 03B0₁₆, bit 4 at address 037D₁₆) = "1": Interrupts requested when data transmission from UART_i transfer register is completed When receiving <ul style="list-style-type: none"> Interrupts requested when data transfer from UART_i receive register to UART_i receive buffer register is completed
Error detection	<ul style="list-style-type: none"> Overrun error (Note 2) This error occurs when the next data is ready before contents of UART_i receive buffer register are read out

Note 1: "n" denotes the value 00₁₆ to FF₁₆ that is set to the UART bit rate generator.

Note 2: If an overrun error occurs, the UART_i receive buffer will have the next data written in. Note also that the UART_i receive interrupt request bit does not change.

Table 1.16.3. Specifications of clock synchronous serial I/O mode (2)

Item	Specification
Select function	<ul style="list-style-type: none"> • CLK polarity selection Whether transmit data is output/input timing at the rising edge or falling edge of the transfer clock can be selected • LSB first/MSB first selection Whether transmission/reception begins with bit 0 or bit 7 can be selected • Continuous receive mode selection Reception is enabled simultaneously by a read from the receive buffer register • Transfer clock output from multiple pins selection (UART1) UART1 transfer clock can be chosen by software to be output from one of the two pins set • Switching serial data logic (UART2) Whether to reverse data in writing to the transmission buffer register or reading the reception buffer register can be selected. • TxD, RxD I/O polarity reverse (UART2) This function is reversing TxD port output and RxD port input. All I/O data level is reversed.

Clock synchronous serial I/O mode

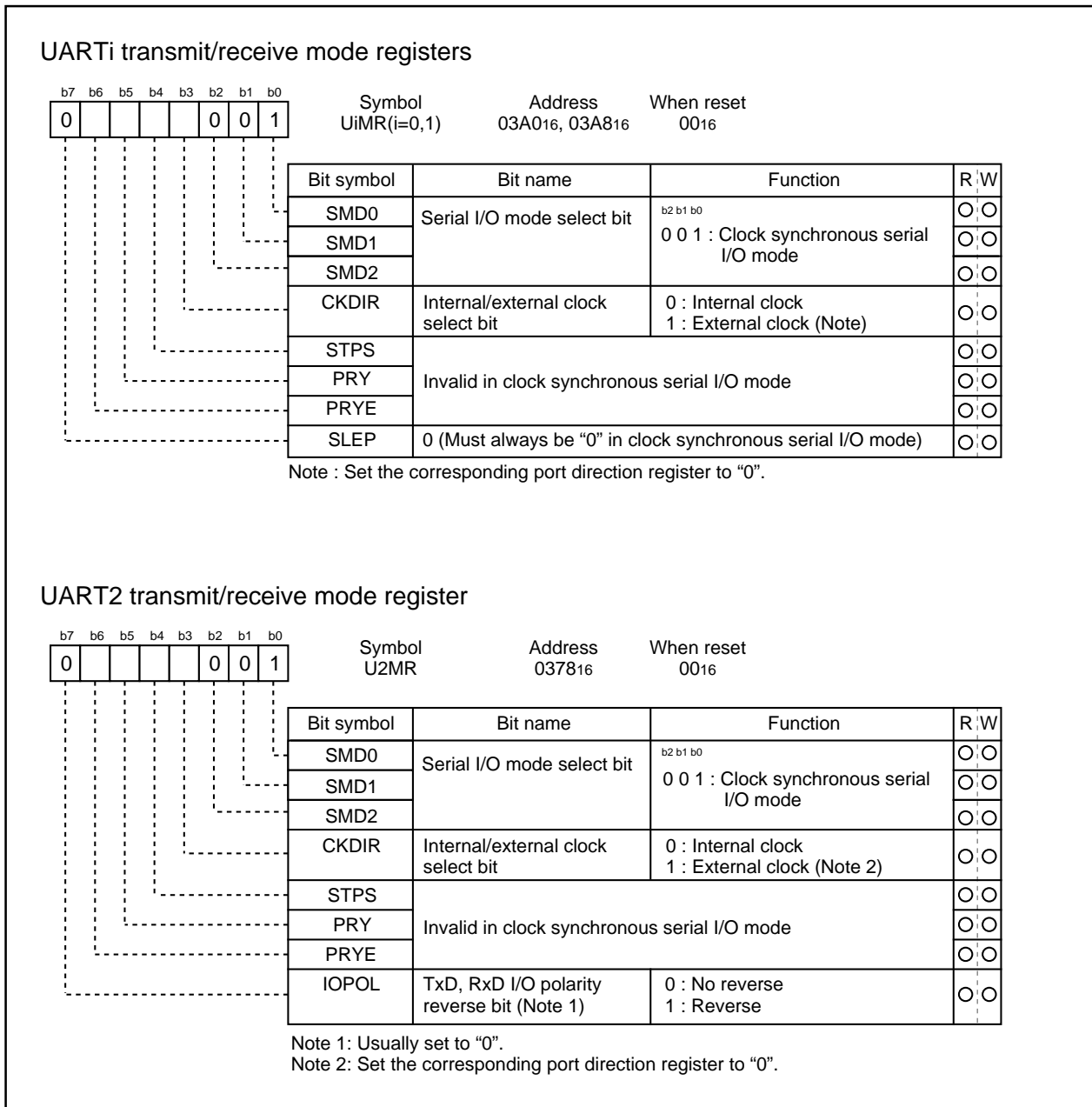

Figure 1.16.10. UARTi transmit/receive mode register in clock synchronous serial I/O mode

Clock synchronous serial I/O mode

Table 1.16.4 lists the functions of the input/output pins during clock synchronous serial I/O mode. This table shows the pin functions when the transfer clock output from multiple pins function is not selected. Note that for a period from when the UARTi operation mode is selected to when transfer starts, the TxDi pin outputs an "H". (If the N-channel open-drain is selected, this pin is in floating state.)

Table 1.16.4. Input/output pin functions in clock synchronous serial I/O mode
(when transfer clock output from multiple pins is not selected)

Pin name	Function	Method of selection
TxDi (P63, P67, P70)	Serial data output	(Outputs dummy data when performing reception only)
RxDi (P62, P66, P71)	Serial data input	Port P62, P66 and P71 direction register (bits 2 and 6 at address 03EE16, bit 1 at address 03EF16) = "0" (Can be used as an input port when performing transmission only)
CLKi (P61, P65, P72)	Transfer clock output	Internal/external clock select bit (bit 3 at address 03A016, 03A816, 037816) = "0"
	Transfer clock input	Internal/external clock select bit (bit 3 at address 03A016, 03A816, 037816) = "1" Port P61, P65 and P72 direction register (bits 1 and 5 at address 03EE16, bit 2 at address 03EF16) = "0"
CTS \bar i/RTS \bar i (P60, P64, P73)	CTS \bar input	CTS \bar /RTS \bar disable bit (bit 4 at address 03A416, 03AC16, 037C16) = "0" CTS \bar /RTS function select bit (bit 2 at address 03A416, 03AC16, 037C16) = "0" Port P60, P64 and P73 direction register (bits 0 and 4 at address 03EE16, bit 3 at address 03EF16) = "0"
	RTS \bar output	CTS \bar /RTS \bar disable bit (bit 4 at address 03A416, 03AC16, 037C16) = "0" CTS \bar /RTS function select bit (bit 2 at address 03A416, 03AC16, 037C16) = "1"
	Programmable I/O port	CTS \bar /RTS \bar disable bit (bit 4 at address 03A416, 03AC16, 037C16) = "1"

Clock synchronous serial I/O mode

• Example of transmit timing (when internal clock is selected)

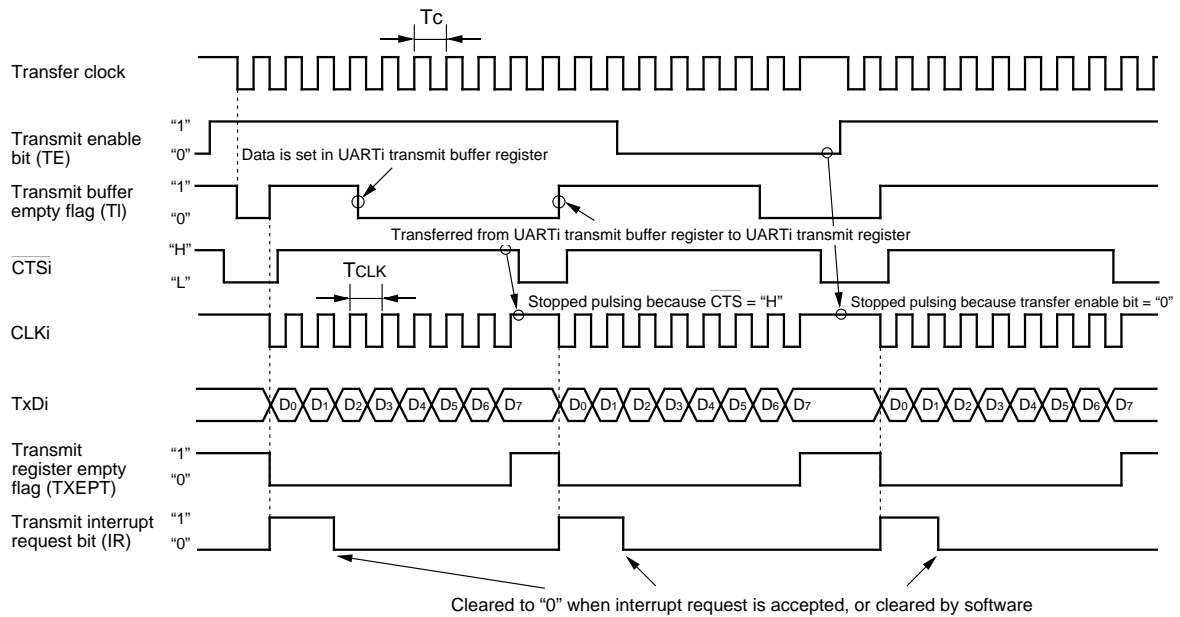

• Example of receive timing (when external clock is selected)

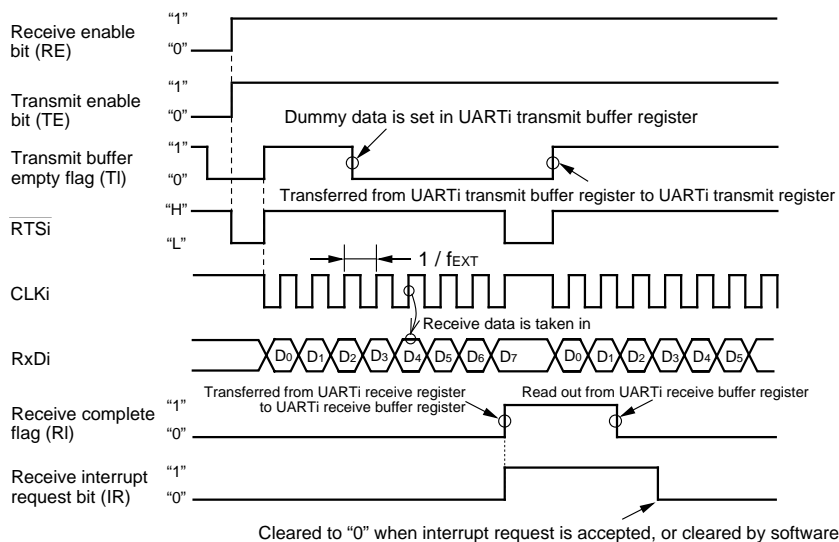

Figure 1.16.11. Typical transmit/receive timings in clock synchronous serial I/O mode

Clock synchronous serial I/O mode

(a) Polarity select function

As shown in Figure 1.16.12, the CLK polarity select bit (bit 6 at addresses 03A4₁₆, 03AC₁₆, 037C₁₆) allows selection of the polarity of the transfer clock.

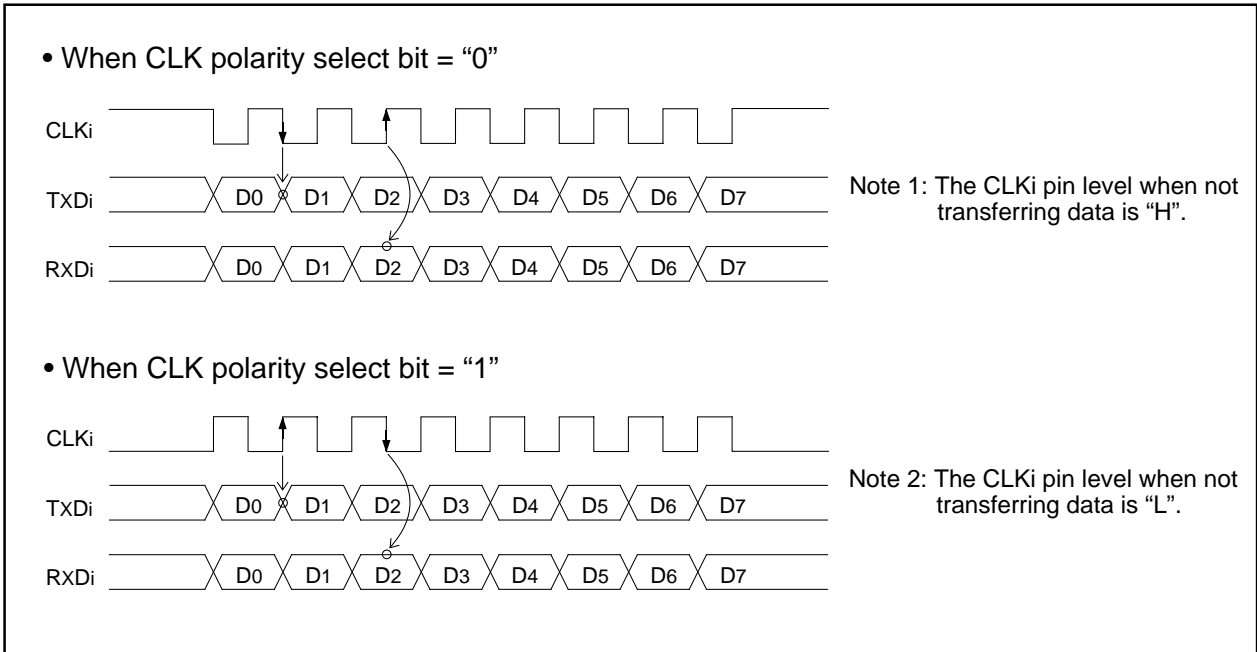

Figure 1.16.12. Polarity of transfer clock

(b) LSB first/MSB first select function

As shown in Figure 1.16.13, when the transfer format select bit (bit 7 at addresses 03A4₁₆, 03AC₁₆, 037C₁₆) = "0", the transfer format is "LSB first"; when the bit = "1", the transfer format is "MSB first".

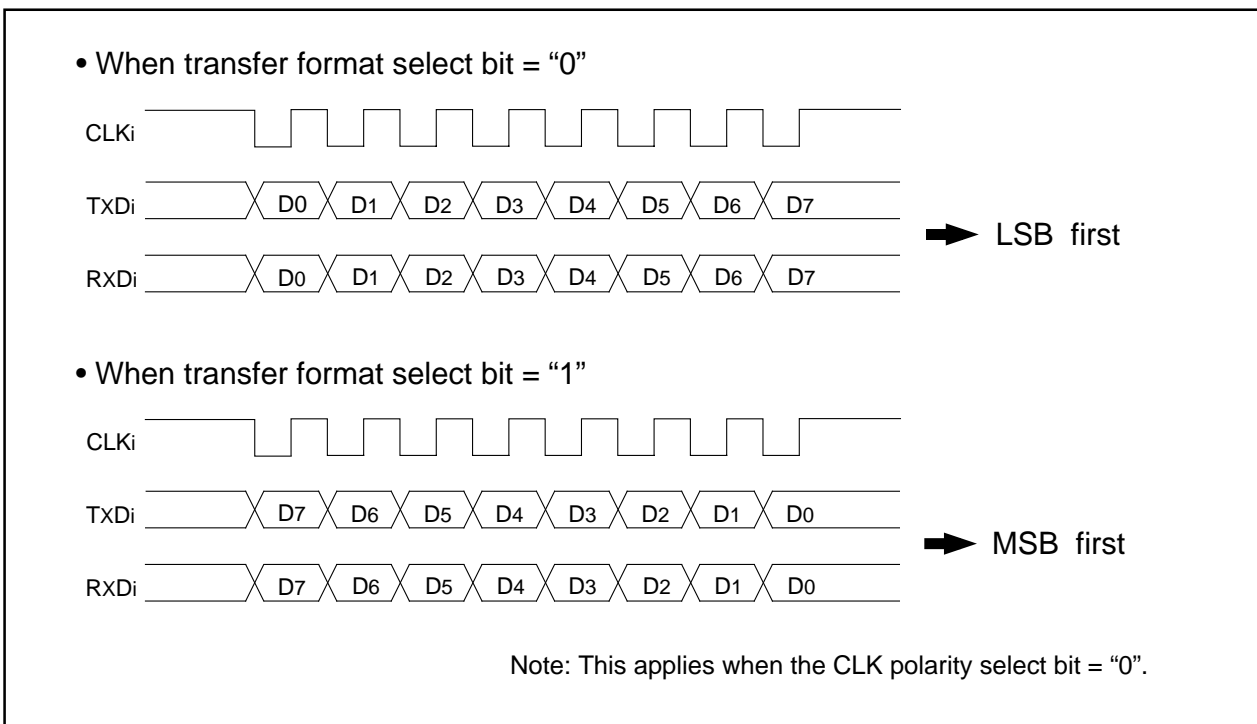

Figure 1.16.13. Transfer format

Clock synchronous serial I/O mode

(c) Transfer clock output from multiple pins function (UART1)

This function allows the setting two transfer clock output pins and choosing one of the two to output a clock by using the CLK and CLKS select bit (bits 4 and 5 at address 03B016). (See Figure 1.16.14.) The multiple pins function is valid only when the internal clock is selected for UART1.

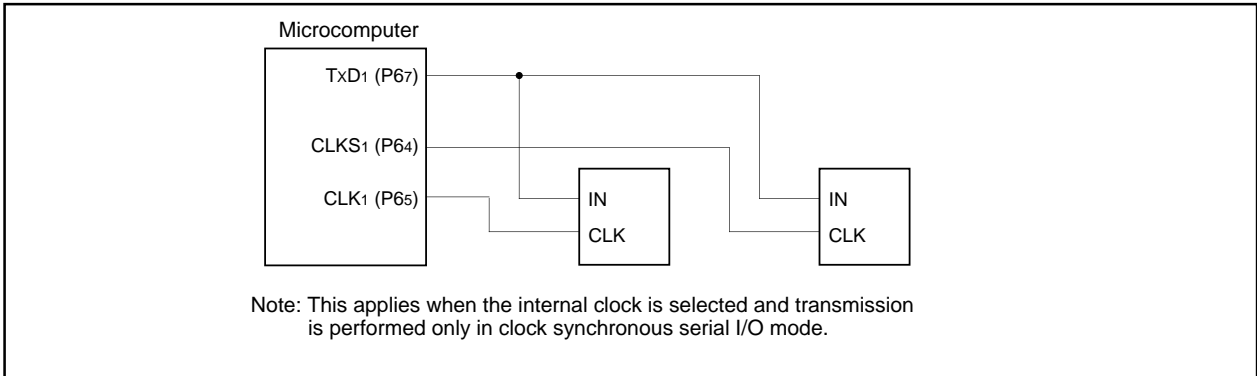

Figure 1.16.14. The transfer clock output from the multiple pins function usage

(d) Continuous receive mode

If the continuous receive mode enable bit (bits 2 and 3 at address 03B016, bit 5 at address 037D16) is set to "1", the unit is placed in continuous receive mode. In this mode, when the receive buffer register is read out, the unit simultaneously goes to a receive enable state without having to set dummy data to the transmit buffer register back again.

(e) Serial data logic switch function (UART2)

When the data logic select bit (bit6 at address 037D16) = "1", and writing to transmit buffer register or reading from receive buffer register, data is reversed. Figure 1.16.15 shows the example of serial data logic switch timing.

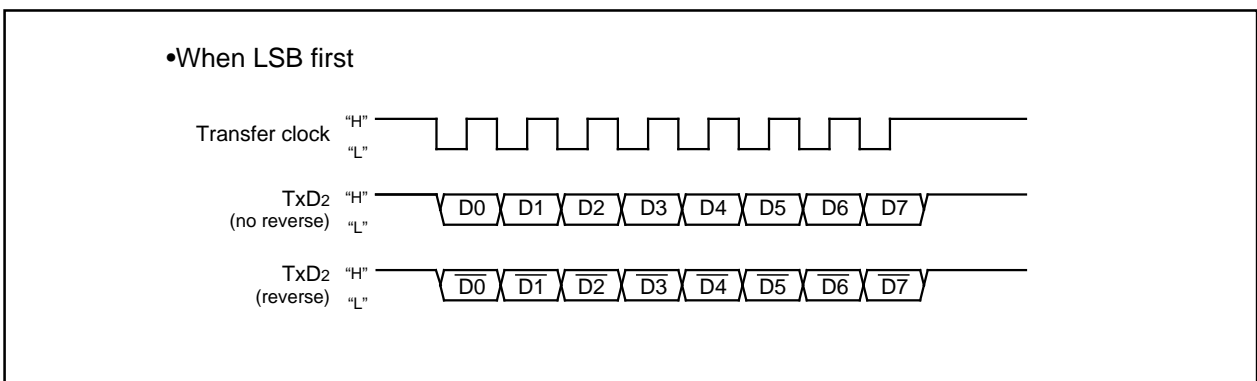

Figure 1.16.15. Serial data logic switch timing

Clock asynchronous serial I/O (UART) mode

(2) Clock asynchronous serial I/O (UART) mode

The UART mode allows transmitting and receiving data after setting the desired transfer rate and transfer data format. Tables 1.16.5 and 1.16.6 list the specifications of the UART mode. Figure 1.16.16 shows the UARTi transmit/receive mode register.

Table 1.16.5. Specifications of UART Mode (1)

Item	Specification
Transfer data format	<ul style="list-style-type: none"> • Character bit (transfer data): 7 bits, 8 bits, or 9 bits as selected • Start bit: 1 bit • Parity bit: Odd, even, or nothing as selected • Stop bit: 1 bit or 2 bits as selected
Transfer clock	<ul style="list-style-type: none"> • When internal clock is selected (bit 3 at addresses 03A0₁₆, 03A8₁₆, 0378₁₆ = "0") : $f_i/16(n+1)$ (Note 1) $f_i = f_1, f_8, f_{32}$ • When external clock is selected (bit 3 at addresses 03A0₁₆, 03A8₁₆ = "1") : $f_{EXT}/16(n+1)$ (Note 1) (Note 2) (Do not set external clock for UART2)
Transmission/reception control	<ul style="list-style-type: none"> • \overline{CTS} function, \overline{RTS} function, \overline{CTS} and \overline{RTS} function invalid: selectable
Transmission start condition	<ul style="list-style-type: none"> • To start transmission, the following requirements must be met: <ul style="list-style-type: none"> - Transmit enable bit (bit 0 at addresses 03A5₁₆, 03AD₁₆, 037D₁₆) = "1" - Transmit buffer empty flag (bit 1 at addresses 03A5₁₆, 03AD₁₆, 037D₁₆) = "0" - When \overline{CTS} function selected, \overline{CTS} input level = "L"
Reception start condition	<ul style="list-style-type: none"> • To start reception, the following requirements must be met: <ul style="list-style-type: none"> - Receive enable bit (bit 2 at addresses 03A5₁₆, 03AD₁₆, 037D₁₆) = "1" - Start bit detection
Interrupt request generation timing	<ul style="list-style-type: none"> • When transmitting <ul style="list-style-type: none"> - Transmit interrupt cause select bits (bits 0,1 at address 03B0₁₆, bit4 at address 037D₁₆) = "0": Interrupts requested when data transfer from UARTi transfer buffer register to UARTi transmit register is completed - Transmit interrupt cause select bits (bits 0, 1 at address 03B0₁₆, bit4 at address 037D₁₆) = "1": Interrupts requested when data transmission from UARTi transfer register is completed • When receiving <ul style="list-style-type: none"> - Interrupts requested when data transfer from UARTi receive register to UARTi receive buffer register is completed
Error detection	<ul style="list-style-type: none"> • Overrun error (Note 3) This error occurs when the next data is ready before contents of UARTi receive buffer register are read out • Framing error This error occurs when the number of stop bits set is not detected • Parity error This error occurs when if parity is enabled, the number of 1's in parity and character bits does not match the number of 1's set • Error sum flag This flag is set (= 1) when any of the overrun, framing, and parity errors is encountered

Note 1: 'n' denotes the value 00₁₆ to FF₁₆ that is set to the UARTi bit rate generator.

Note 2: f_{EXT} is input from the CLKi pin.

Note 3: If an overrun error occurs, the UARTi receive buffer will have the next data written in. Note also that the UARTi receive interrupt request bit does not change.

Clock asynchronous serial I/O (UART) mode

Table 1.16.6. Specifications of UART Mode (2)

Item	Specification
Select function	<ul style="list-style-type: none"><li data-bbox="507 342 1414 454">• Sleep mode selection (UART0, UART1) This mode is used to transfer data to and from one of multiple slave micro-computers<li data-bbox="507 465 1414 577">• Serial data logic switch (UART2) This function is reversing logic value of transferring data. Start bit, parity bit and stop bit are not reversed.<li data-bbox="507 589 1414 678">• TxD, RxD I/O polarity switch (UART2) This function is reversing TxD port output and RxD port input. All I/O data level is reversed.

Clock asynchronous serial I/O (UART) mode

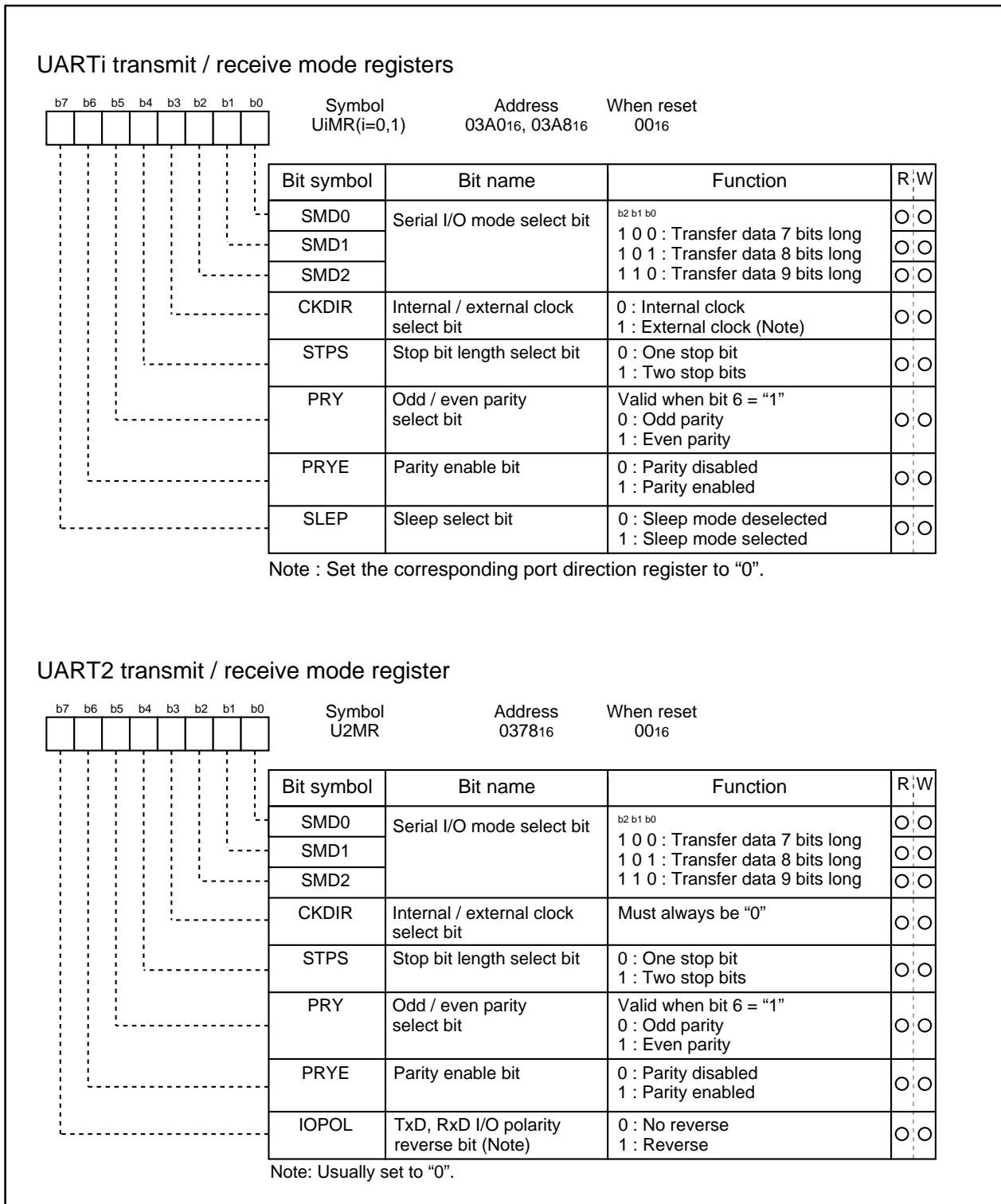

Figure 1.16.16. UART_i transmit/receive mode register in UART mode

Clock asynchronous serial I/O (UART) mode

Table 1.16.7 lists the functions of the input/output pins during UART mode. Note that for a period from when the UARTi operation mode is selected to when transfer starts, the TxDi pin outputs an "H". (If the N-channel open-drain is selected, this pin is in floating state.)

Table 1.16.7. Input/output pin functions in UART mode

Pin name	Function	Method of selection
TxDi (P63, P67, P70)	Serial data output	
RxDi (P62, P66, P71)	Serial data input	Port P62, P66 and P71 direction register (bits 2 and 6 at address 03EE16, bit 1 at address 03EF16) = "0" (Can be used as an input port when performing transmission only)
CLKi (P61, P65, P72)	Programmable I/O port	Internal/external clock select bit (bit 3 at address 03A016, 03A816, 037816) = "0"
	Transfer clock input	Internal/external clock select bit (bit 3 at address 03A016, 03A816) = "1" Port P61, P65 direction register (bits 1 and 5 at address 03EE16) = "0" (Do not set external clock for UART2)
$\overline{\text{CTS}}/\overline{\text{RTS}}_i$ (P60, P64, P73)	$\overline{\text{CTS}}$ input	$\overline{\text{CTS}}/\overline{\text{RTS}}$ disable bit (bit 4 at address 03A416, 03AC16, 037C16) = "0" $\overline{\text{CTS}}/\overline{\text{RTS}}$ function select bit (bit 2 at address 03A416, 03AC16, 037C16) = "0" Port P60, P64 and P73 direction register (bits 0 and 4 at address 03EE16, bit 3 at address 03EF16) = "0"
	RTS output	$\overline{\text{CTS}}/\overline{\text{RTS}}$ disable bit (bit 4 at address 03A416, 03AC16, 037C16) = "0" $\overline{\text{CTS}}/\overline{\text{RTS}}$ function select bit (bit 2 at address 03A416, 03AC16, 037C16) = "1"
	Programmable I/O port	$\overline{\text{CTS}}/\overline{\text{RTS}}$ disable bit (bit 4 at address 03A416, 03AC16, 037C16) = "1"

Clock asynchronous serial I/O (UART) mode

• Example of transmit timing when transfer data is 8 bits long (parity enabled, one stop bit)

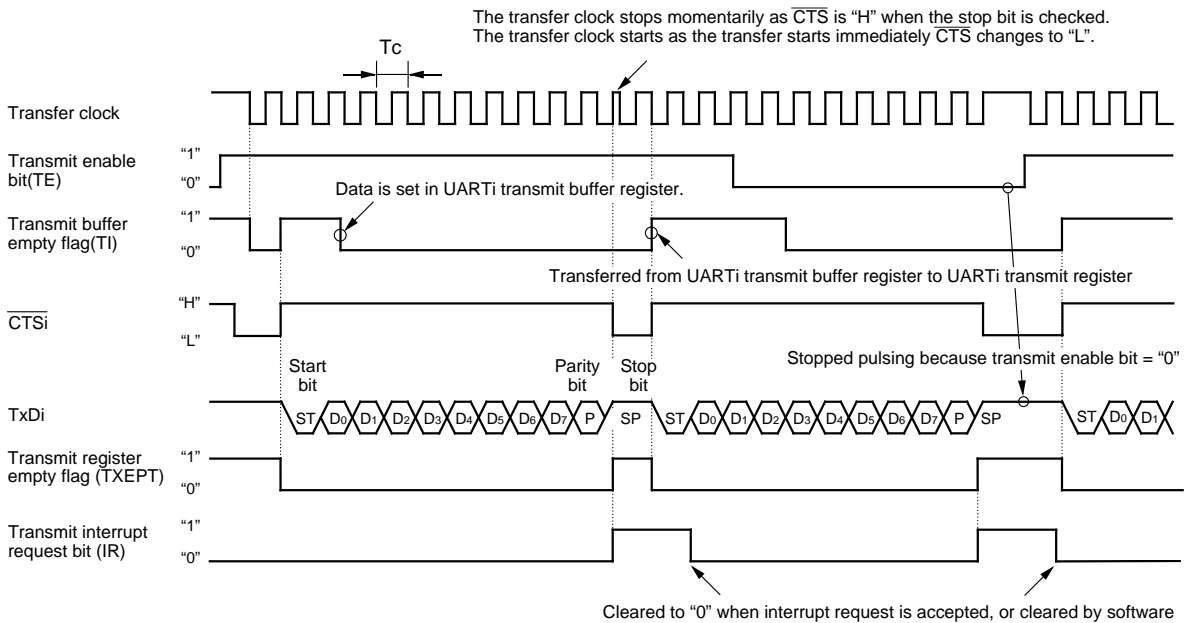

• Example of transmit timing when transfer data is 9 bits long (parity disabled, two stop bits)

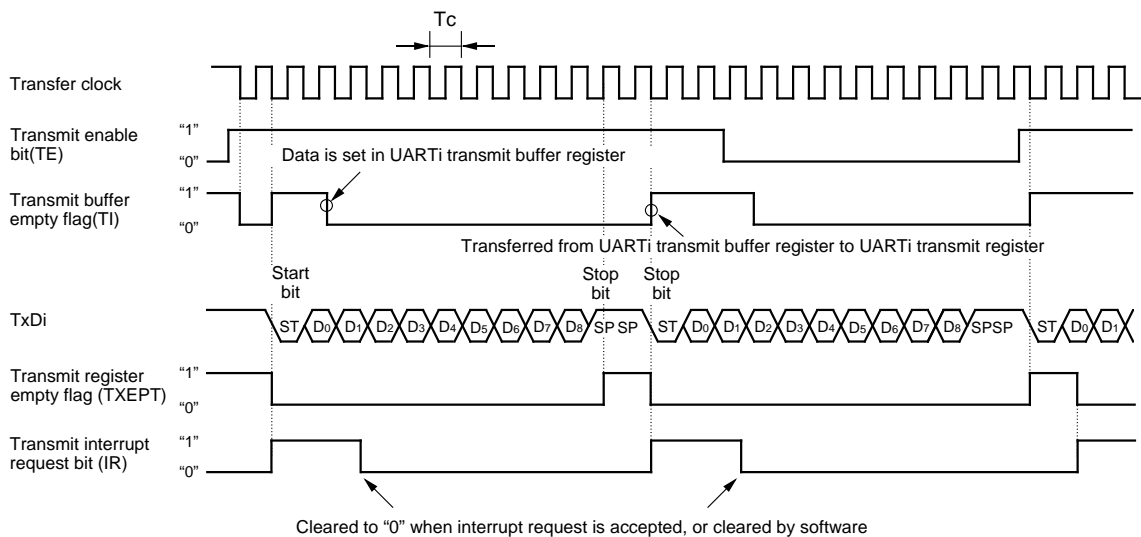

Figure 1.16.17. Typical transmit timings in UART mode(UART0,UART1)

Clock asynchronous serial I/O (UART) mode

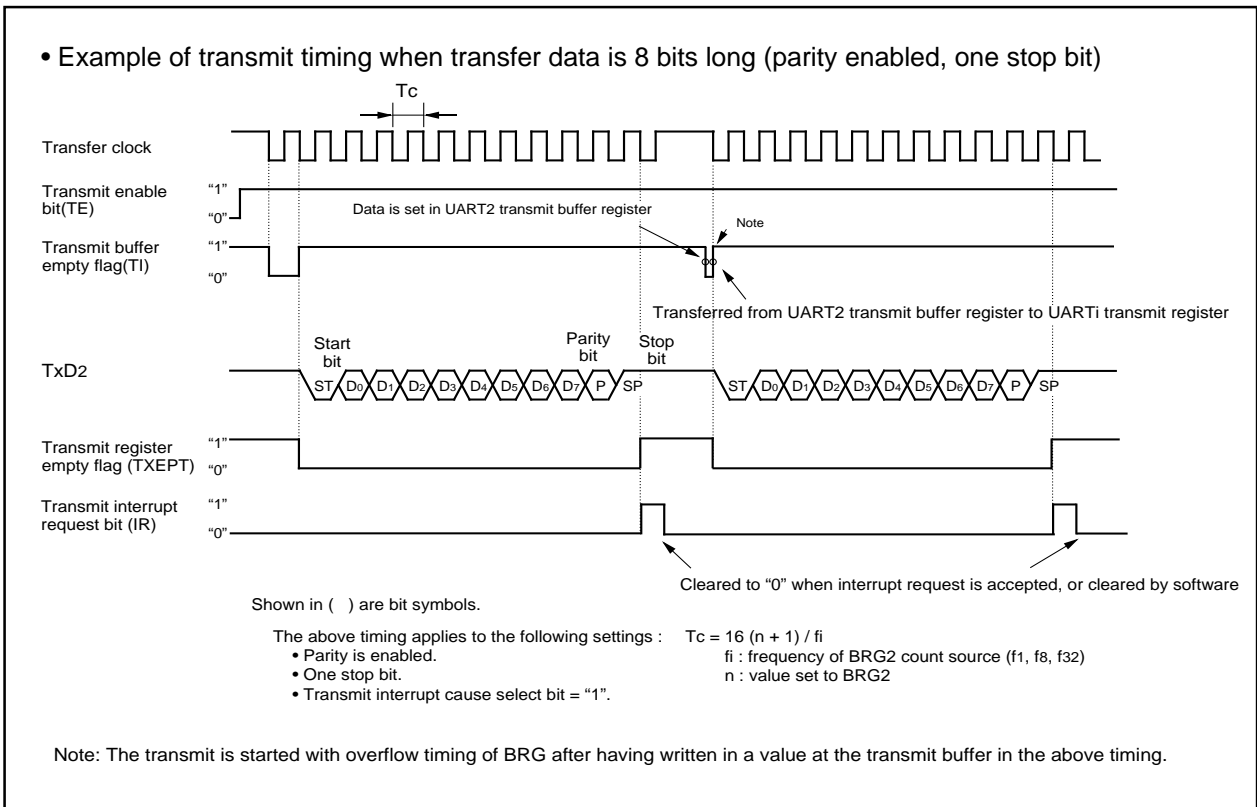

Figure 1.16.18. Typical transmit timings in UART mode(UART2)

Clock asynchronous serial I/O (UART) mode

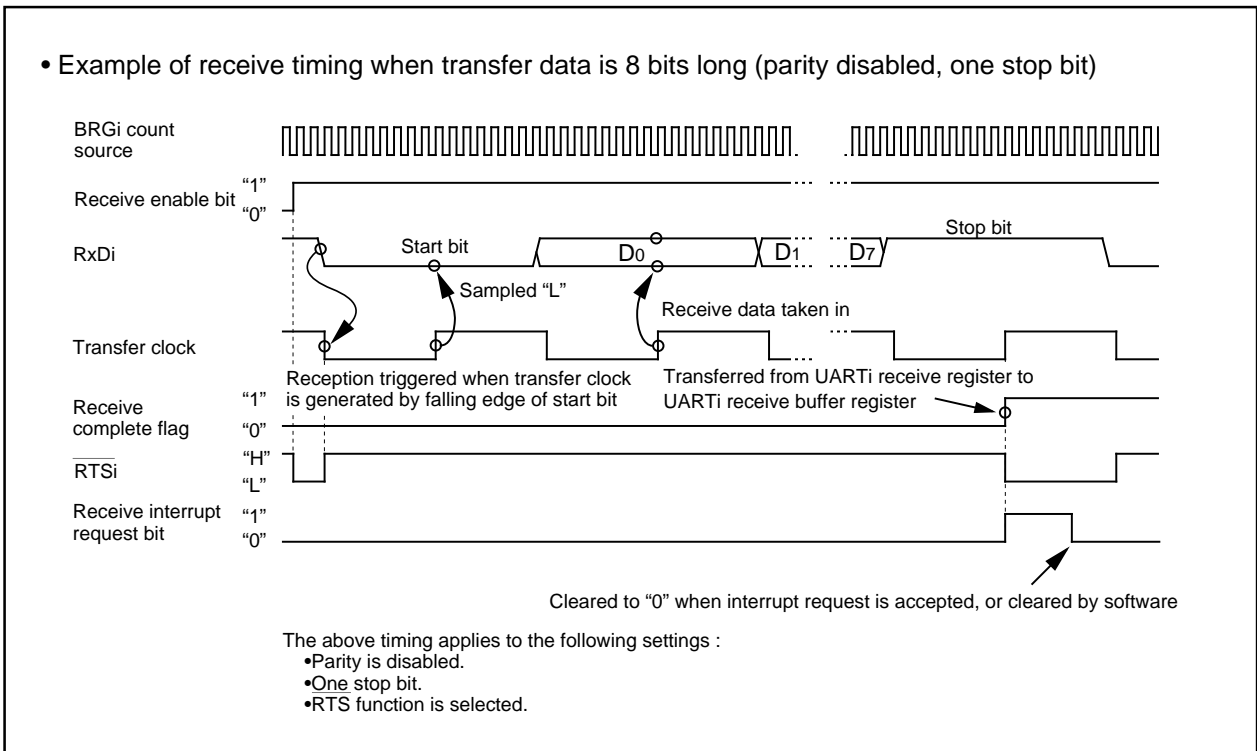

Figure 1.16.19. Typical receive timing in UART mode

(a) Sleep mode (UART0, UART1)

This mode is used to transfer data between specific microcomputers among multiple microcomputers connected using UARTi. The sleep mode is selected when the sleep select bit (bit 7 at addresses 03A016, 03A816) is set to "1" during reception. In this mode, the unit performs receive operation when the MSB of the received data = "1" and does not perform receive operation when the MSB = "0".

(b) Function for switching serial data logic (UART2)

When the data logic select bit (bit 6 of address 037D16) is assigned "1", data is inverted in writing to the transmission buffer register or reading the reception buffer register. Figure 1.16.20 shows the example of timing for switching serial data logic.

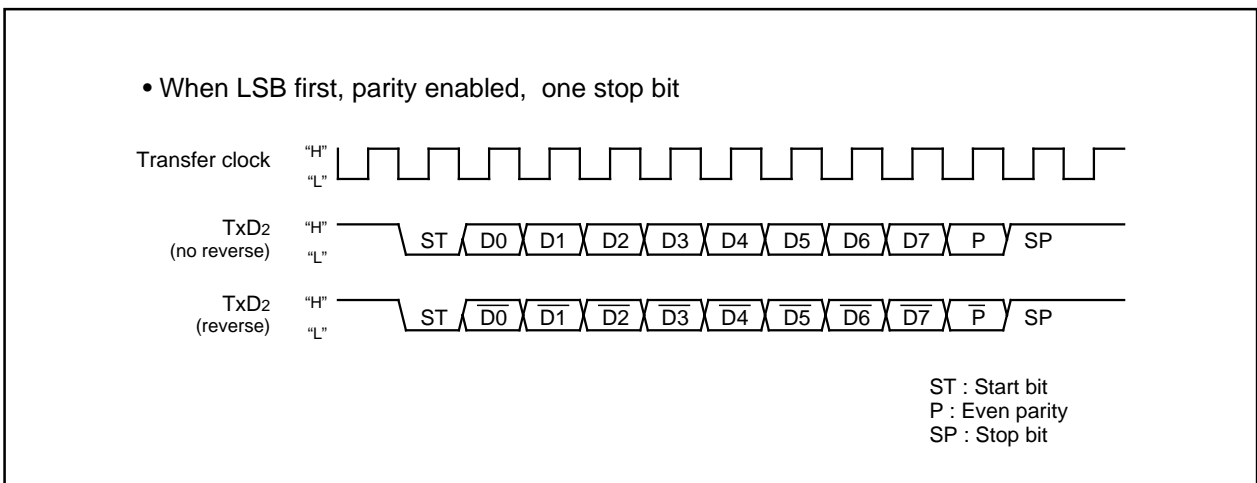

Figure 1.16.20. Timing for switching serial data logic

Clock asynchronous serial I/O (UART) mode

(c) TxD, RxD I/O polarity reverse function (UART2)

This function is to reverse TxD pin output and RxD pin input. The level of any data to be input or output (including the start bit, stop bit(s), and parity bit) is reversed. Set this function to "0" (not to reverse) for usual use.

(d) Bus collision detection function (UART2)

This function is to sample the output level of the TxD pin and the input level of the RxD pin at the rising edge of the transfer clock; if their values are different, then an interrupt request occurs. Figure 1.16.21 shows the example of detection timing of a bus collision (in UART mode).

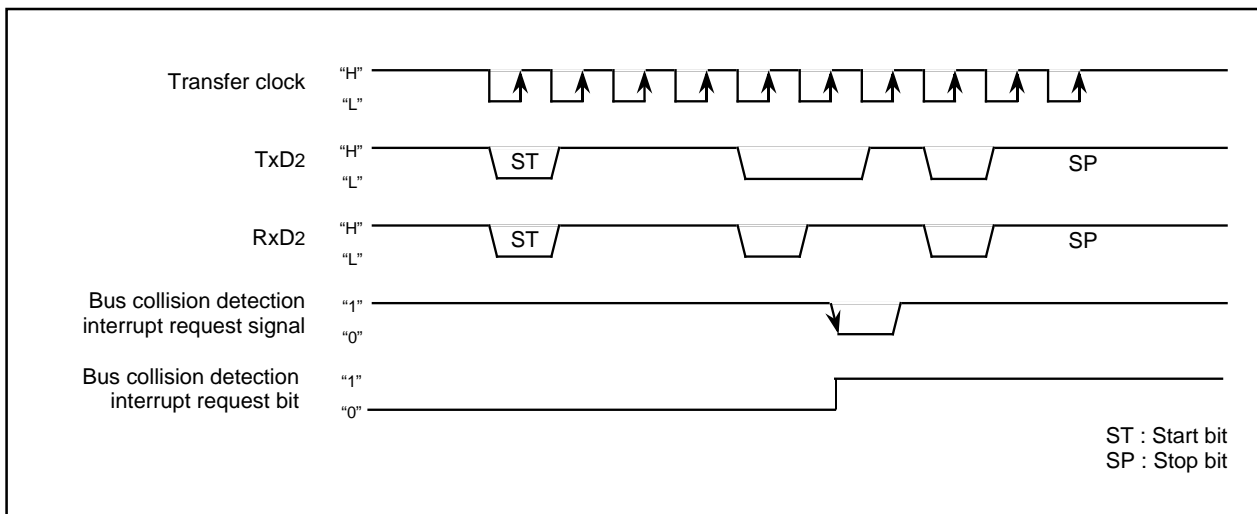

Figure 1.16.21. Detection timing of a bus collision (in UART mode)

Clock asynchronous serial I/O (UART) mode

(3) Clock-asynchronous serial I/O mode (used for the SIM interface)

The SIM interface is used for connecting the microcomputer with a memory card or the like; adding some extra settings in UART2 clock-asynchronous serial I/O mode allows the user to effect this function. Table 1.16.8 shows the specifications of clock-asynchronous serial I/O mode (used for the SIM interface).

Table 1.16.8. Specifications of clock-asynchronous serial I/O mode (used for the SIM interface)

Item	Specification
Transfer data format	<ul style="list-style-type: none"> • Transfer data 8-bit UART mode (bit 2 through bit 0 of address 0378₁₆ = "1012") • One stop bit (bit 4 of address 0378₁₆ = "0") • With the direct format chosen <ul style="list-style-type: none"> Set parity to "even" (bit 5 and bit 6 of address 0378₁₆ = "1" and "1" respectively) Set data logic to "direct" (bit 6 of address 037D₁₆ = "0"). Set transfer format to LSB (bit 7 of address 037C₁₆ = "0"). • With the inverse format chosen <ul style="list-style-type: none"> Set parity to "odd" (bit 5 and bit 6 of address 0378₁₆ = "0" and "1" respectively) Set data logic to "inverse" (bit 6 of address 037D₁₆ = "1") Set transfer format to MSB (bit 7 of address 037C₁₆ = "1")
Transfer clock	<ul style="list-style-type: none"> • With the internal clock chosen (bit 3 of address 0378₁₆ = "0") : $f_i / 16 (n + 1)$ (Note 1) : $f_i = f_1, f_8, f_{32}$ (Do not set external clock)
Transmission / reception control	<ul style="list-style-type: none"> • Disable the $\overline{\text{CTS}}$ and $\overline{\text{RTS}}$ function (bit 4 of address 037C₁₆ = "1")
Other settings	<ul style="list-style-type: none"> • The sleep mode select function is not available for UART2 • Set transmission interrupt factor to "transmission completed" (bit 4 of address 037D₁₆ = "1")
Transmission start condition	<ul style="list-style-type: none"> • To start transmission, the following requirements must be met: <ul style="list-style-type: none"> - Transmit enable bit (bit 0 of address 037D₁₆) = "1" - Transmit buffer empty flag (bit 1 of address 037D₁₆) = "0"
Reception start condition	<ul style="list-style-type: none"> • To start reception, the following requirements must be met: <ul style="list-style-type: none"> - Reception enable bit (bit 2 of address 037D₁₆) = "1" - Detection of a start bit
Interrupt request generation timing	<ul style="list-style-type: none"> • When transmitting <ul style="list-style-type: none"> When data transmission from the UART2 transmit register is completed (bit 4 of address 037D₁₆ = "1") • When receiving <ul style="list-style-type: none"> When data transfer from the UART2 receive register to the UART2 receive buffer register is completed
Error detection	<ul style="list-style-type: none"> • Overrun error (see the specifications of clock-asynchronous serial I/O) (Note 2) • Framing error (see the specifications of clock-asynchronous serial I/O) • Parity error (see the specifications of clock-asynchronous serial I/O) <ul style="list-style-type: none"> - On the reception side, an "L" level is output from the TxD₂ pin by use of the parity error signal output function (bit 7 of address 037D₁₆ = "1") when a parity error is detected - On the transmission side, a parity error is detected by the level of input to the RxD₂ pin when a transmission interrupt occurs • The error sum flag (see the specifications of clock-asynchronous serial I/O)

Note 1: 'n' denotes the value 00₁₆ to FF₁₆ that is set to the UART2 bit rate generator.

Note 2: If an overrun error occurs, the UART2 receive buffer will have the next data written in. Note also that the UART2 receive interrupt request bit does not change.

Clock asynchronous serial I/O (UART) mode

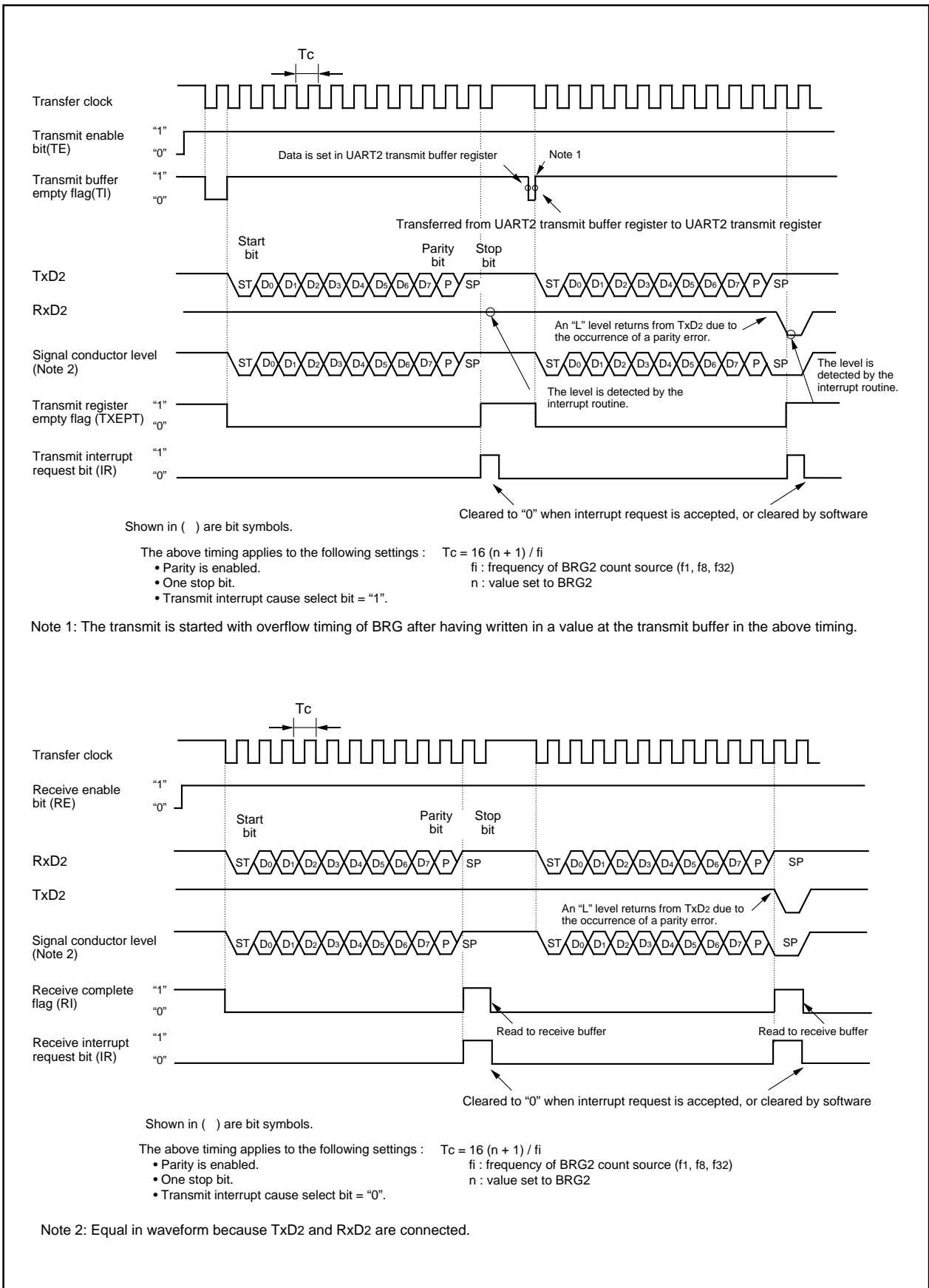

Figure 1.16.22. Typical transmit/receive timing in UART mode (used for the SIM interface)

Clock asynchronous serial I/O (UART) mode

(a) Function for outputting a parity error signal

During reception, with the error signal output enable bit (bit 7 of address 037D16) assigned "1", you can output an "L" level from the TxD2 pin when a parity error is detected. And during transmission, comparing with the case in which the error signal output enable bit (bit 7 of address 037D16) is assigned "0", the transmission completion interrupt occurs in the half cycle later of the transfer clock. Therefore parity error signals can be detected by a transmission completion interrupt program. Figure 1.16.23 shows the output timing of the parity error signal.

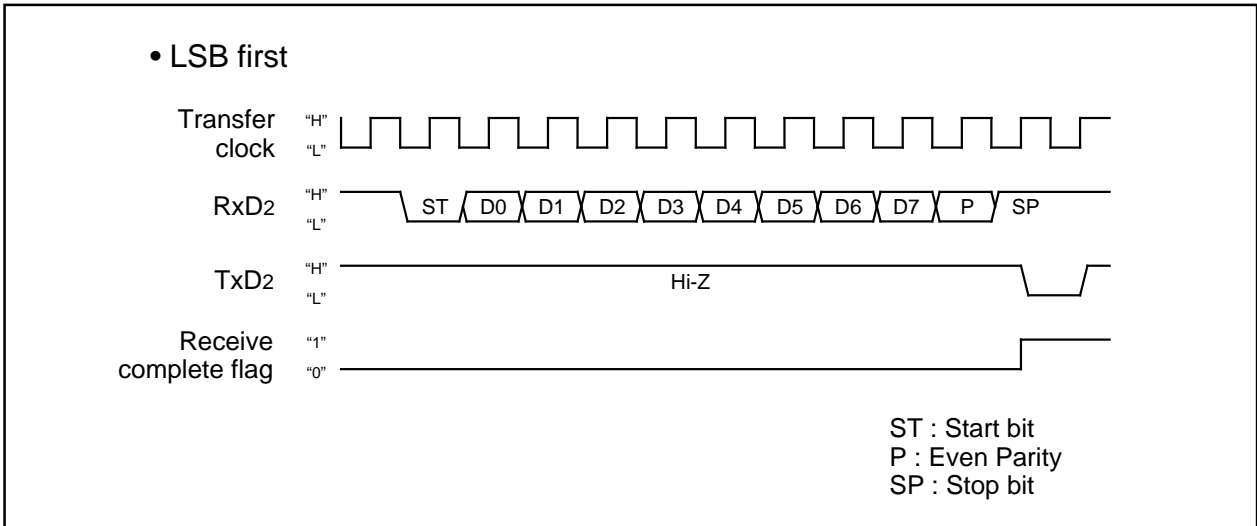

Figure 1.16.23. Output timing of the parity error signal

(b) Direct format/inverse format

Connecting the SIM card allows you to switch between direct format and inverse format. If you choose the direct format, D0 data is output from TxD2. If you choose the inverse format, D7 data is inverted and output from TxD2.

Figure 1.16.24 shows the SIM interface format.

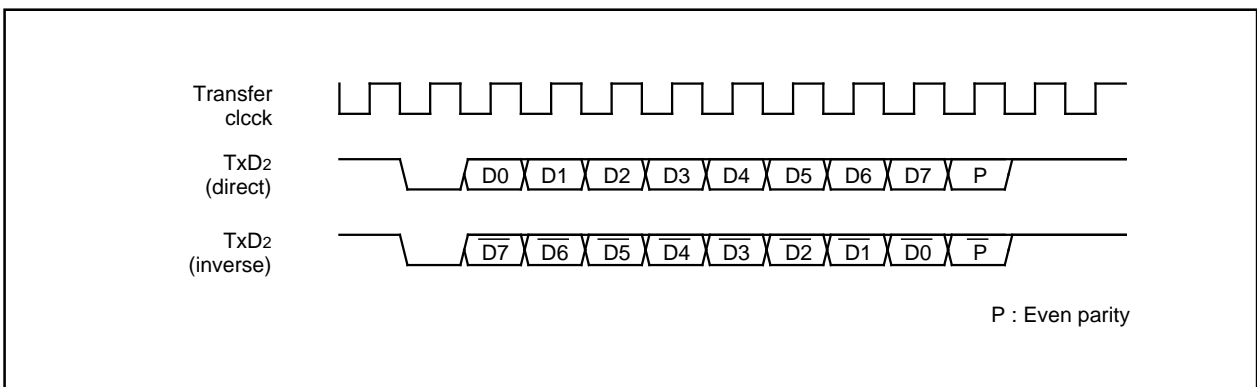

Figure 1.16.24. SIM interface format

Clock asynchronous serial I/O (UART) mode

Figure 1.16.25 shows the example of connecting the SIM interface. Connect TxD2 and RxD2 and apply pull-up.

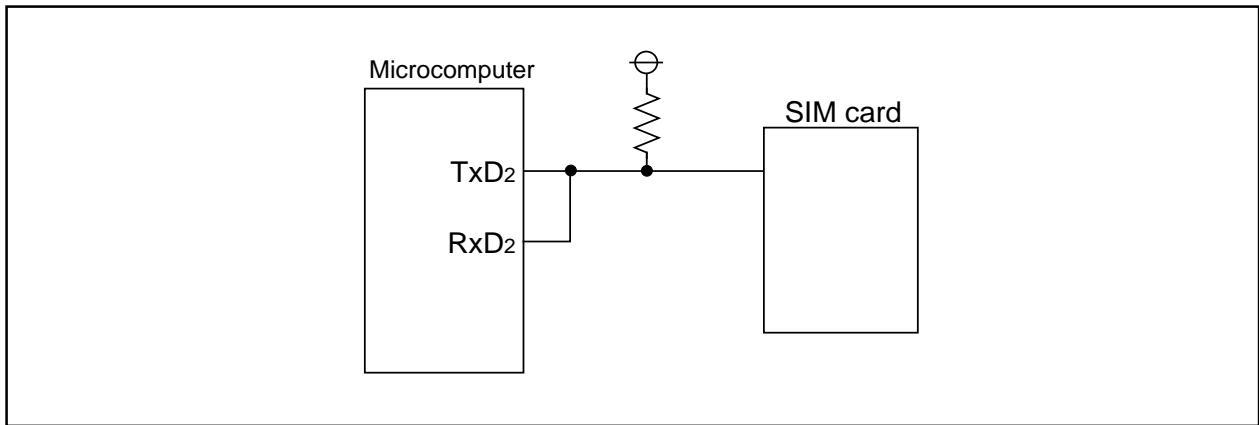

Figure 1.16.25. Connecting the SIM interface

UART2 Special Mode Register

The UART2 special mode register (address 037716) is used to control UART2 in various ways.

Figure 1.16.26 shows the UART2 special mode register.

Bit 0 of the UART2 special mode register (037716) is used as the I²C mode select bit.

Setting “1” in the I²C mode select bit (bit 0) goes the circuit to achieve the I²C bus (simplified I²C bus) interface effective.

Table 1.16.9 shows the relation between the I²C mode select bit and respective control workings.

Since this function uses clock-synchronous serial I/O mode, set this bit to “0” in UART mode.

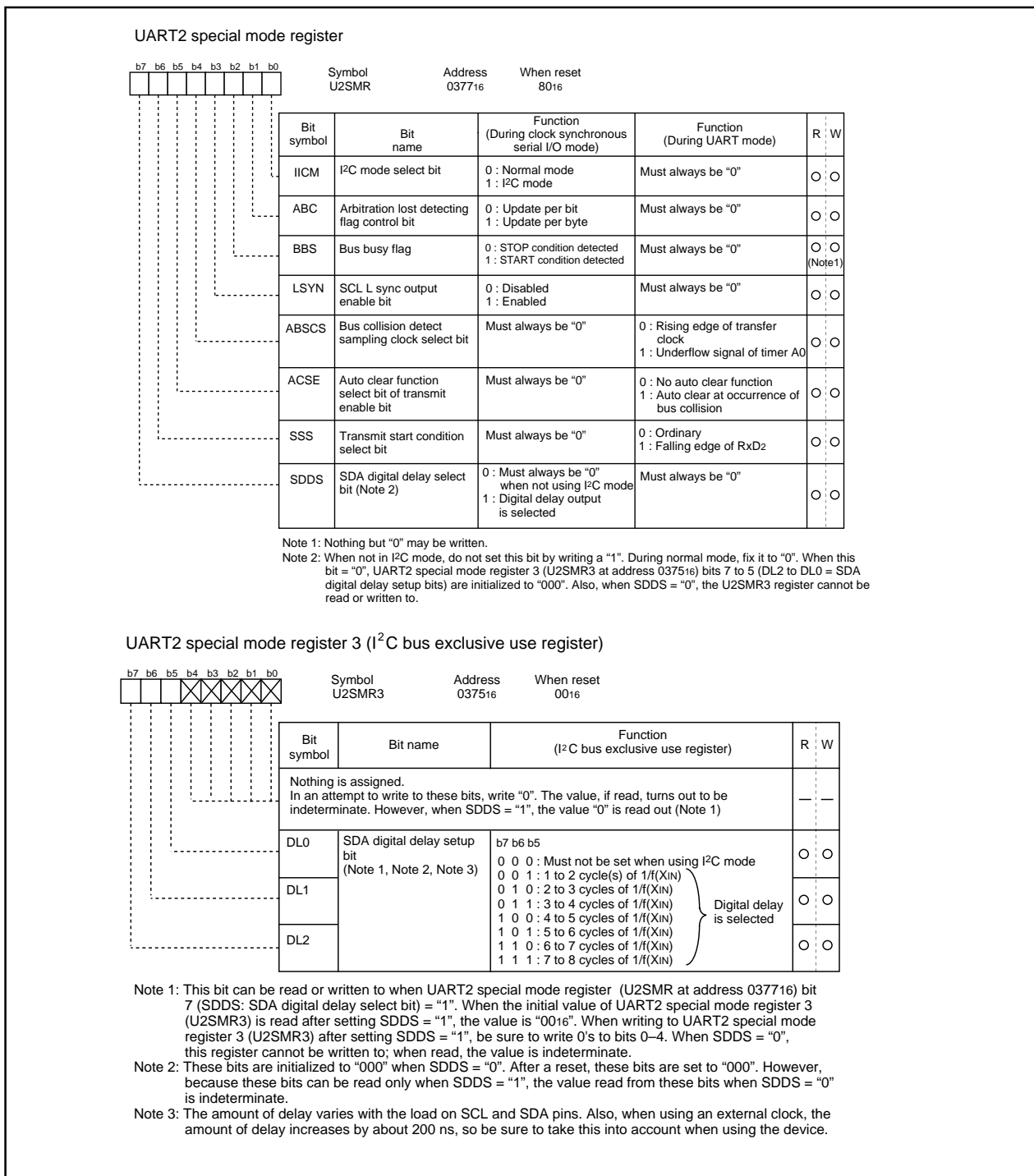

Figure 1.16.26. UART2 special mode register

UART2 Special Mode Register

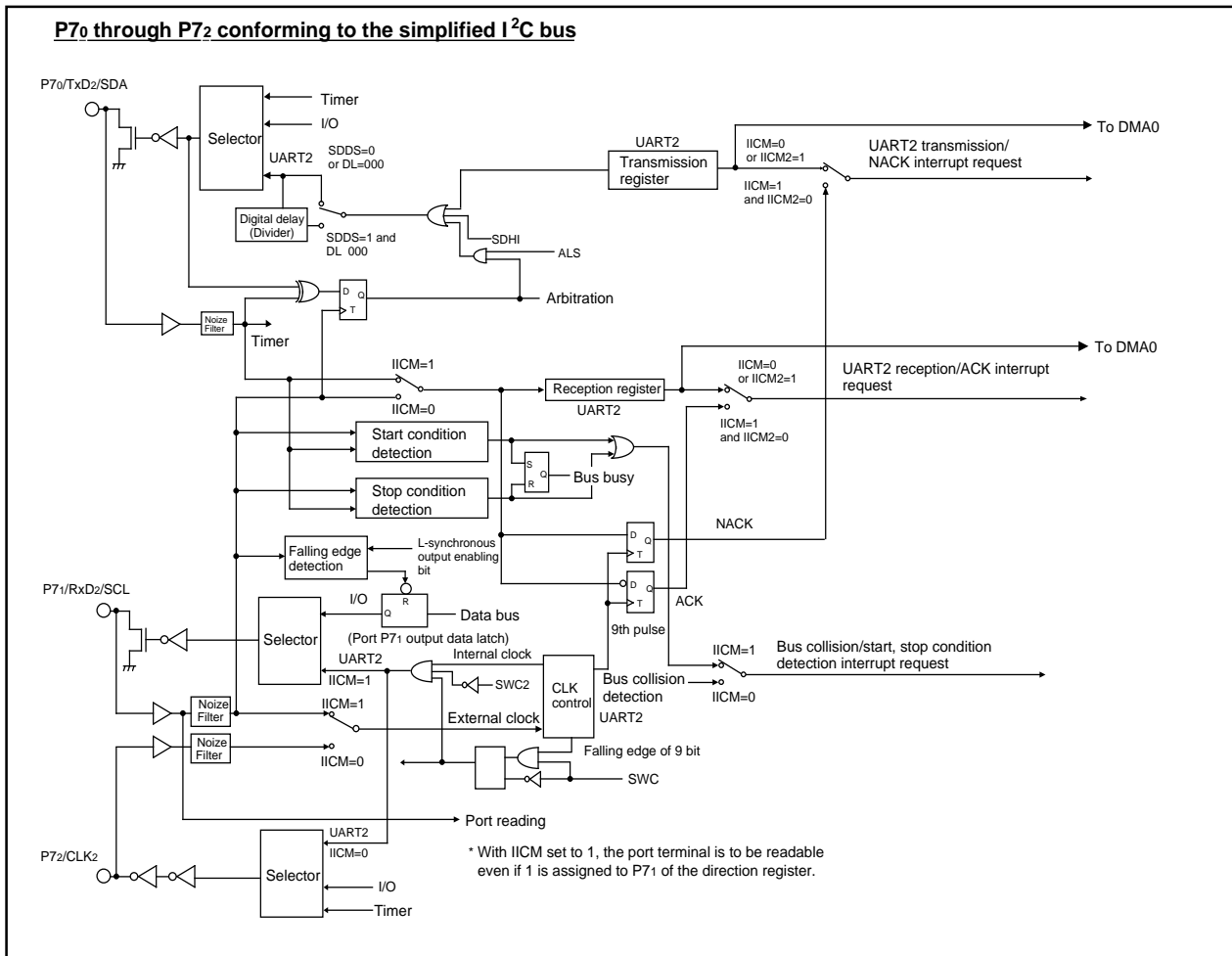

Figure 1.16.27. Functional block diagram for I²C mode

Table 1.16.9. Features in I²C mode

	Function	Normal mode	I ² C mode (Note 1)
1	Factor of interrupt number 10 (Note 2)	Bus collision detection	Start condition detection or stop condition detection
2	Factor of interrupt number 15 (Note 2)	UART2 transmission	No acknowledgment detection (NACK)
3	Factor of interrupt number 16 (Note 2)	UART2 reception	Acknowledgment detection (ACK)
4	UART2 transmission output delay	Not delayed	Delayed (digital delay)
5	P70 at the time when UART2 is in use	TxD2 (output)	SDA (input/output) (Note 3)
6	P71 at the time when UART2 is in use	RxD2 (input)	SCL (input/output)
7	P72 at the time when UART2 is in use	CLK2	P72
8	Noise filter width	15ns	200ns
9	Reading P71	Reading the terminal when 0 is assigned to the direction register	Reading the terminal regardless of the value of the direction register
10	Initial value of UART2 output	H level (when 0 is assigned to the CLK polarity select bit)	The value set in latch P70 when the port is selected

Note 1: Make the settings given below when I²C mode is in use.

Set 0 1 0 in bits 2, 1, 0 of the UART2 transmission/reception mode register.

Disable the RTS/CTS function. Choose the MSB First mode.

Note 2: Follow the steps given below to switch from a factor to another.

1. Disable the interrupt of the corresponding number.
2. Switch from a factor to another.
3. Reset the interrupt request flag of the corresponding number.
4. Set an interrupt level of the corresponding number.

Note 3: Set an initial value of SDA transmission output when serial I/O is invalid.

Figure 1.16.27 shows the functional block diagram for I²C mode. Setting “1” in the I²C mode select bit (IICM) causes ports P70, P71, and P72 to work as data transmission-reception terminal SDA, clock input-output terminal SCL, and port P72 respectively. A delay circuit is added to the SDA transmission output, so the SDA output changes after SCL fully goes to “L”. The amount of delay can be selected in the range of 2 cycles to 8 cycles of f1 using UART2 special mode register 3 (at address 037516). Delay circuit select conditions are shown in Table 1.16.10.

Table 1.16.10. Delay circuit select conditions

	Register value			Contents
	IICM	SDDS	DL	
Digital delay is selected	1	1	001 to 111	Digital delay is added
No delay	0	0	(000)	When IICM = “0”, no delay circuit is selected. When IICM = “0”, however, always make sure SDDS = “0”.

An attempt to read Port P71 (SCL) results in getting the terminal’s level regardless of the content of the port direction register. The initial value of SDA transmission output goes to the value set in port P70. The interrupt factors of the bus collision detection interrupt, UART2 transmission interrupt, and of UART2 reception interrupt turn to the start/stop condition detection interrupt, acknowledgment non-detection interrupt, and acknowledgment detection interrupt respectively.

The start condition detection interrupt refers to the interrupt that occurs when the falling edge of the SDA terminal (P70) is detected with the SCL terminal (P71) staying “H”. The stop condition detection interrupt refers to the interrupt that occurs when the rising edge of the SDA terminal (P70) is detected with the SCL terminal (P71) staying “H”. The bus busy flag (bit 2 of the UART2 special mode register) is set to “1” by the start condition detection, and set to “0” by the stop condition detection.

The acknowledgment non-detection interrupt refers to the interrupt that occurs when the SDA terminal level is detected still staying “H” at the rising edge of the 9th transmission clock. The acknowledgment detection interrupt refers to the interrupt that occurs when SDA terminal’s level is detected already went to “L” at the 9th transmission clock.

Bit 1 of the UART2 special mode register (037716) is used as the arbitration lost detecting flag control bit. Arbitration means the act of detecting the nonconformity between transmission data and SDA terminal data at the timing of the SCL rising edge. This detecting flag is located at bit 11 of the UART2 reception buffer register (037F16, 037E16), and “1” is set in this flag when nonconformity is detected. Use the arbitration lost detecting flag control bit to choose which way to use to update the flag, bit by bit or byte by byte. When setting this bit to “1” and updated the flag byte by byte if nonconformity is detected, the arbitration lost detecting flag is set to “1” at the falling edge of the 9th transmission clock.

If update the flag byte by byte, must judge and clear (“0”) the arbitration lost detecting flag after completing the first byte acknowledge detect and before starting the next one byte transmission.

Bit 3 of the UART2 special mode register is used as SCL- and L-synchronous output enable bit. Setting this bit to “1” goes the P71 data register to “0” in synchronization with the SCL terminal level going to “L”.

UART2 Special Mode Register

Some other functions added are explained here. Figure 1.16.28 shows their workings.

Bit 4 of the UART2 special mode register is used as the bus collision detect sampling clock select bit. The bus collision detect interrupt occurs when the RxD2 level and TxD2 level do not match, but the nonconformity is detected in synchronization with the rising edge of the transfer clock signal if the bit is set to "0". If this bit is set to "1", the nonconformity is detected at the timing of the overflow of timer A0 rather than at the rising edge of the transfer clock.

Bit 5 of the UART2 special mode register is used as the auto clear function select bit of transmit enable bit. Setting this bit to "1" automatically resets the transmit enable bit to "0" when "1" is set in the bus collision detect interrupt request bit (nonconformity).

Bit 6 of the UART2 special mode register is used as the transmit start condition select bit. Setting this bit to "1" starts the TxD transmission in synchronization with the falling edge of the RxD terminal.

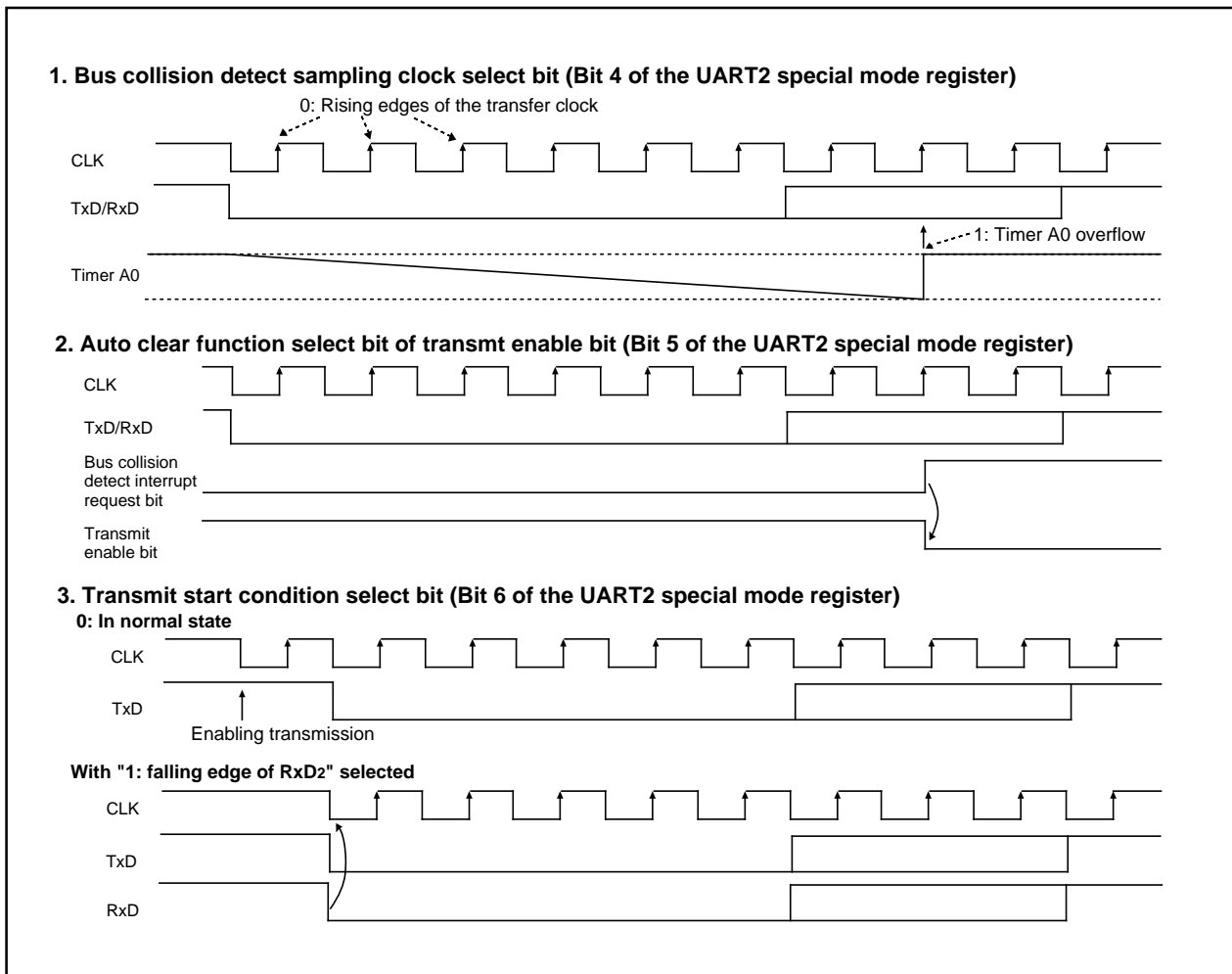

Figure 1.16.28. Some other functions added

UART2 Special Mode Register 2

UART2 special mode register 2 (address 0376₁₆) is used to further control UART2 in I²C mode. Figure 1.16.29 shows the UART2 special mode register 2.

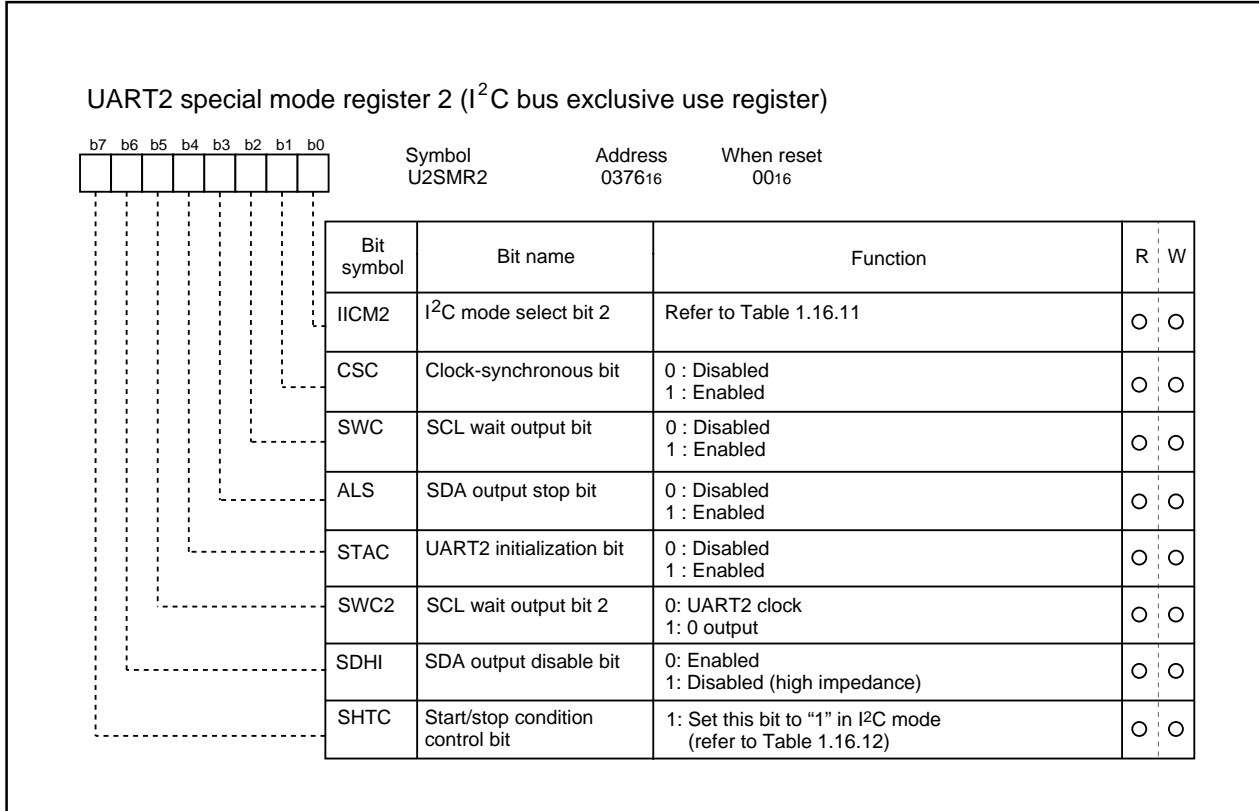

Figure 1.16.29. UART2 special mode register 2

Bit 0 of the UART2 special mode register 2 (address 037616) is used as the I²C mode select bit 2. Table 1.16.11 shows the types of control to be changed by I²C mode select bit 2 when the I²C mode select bit is set to “1”. Table 1.16.12 shows the timing characteristics of detecting the start condition and the stop condition. Set the start/stop condition control bit (bit 7 of UART2 special mode register 2) to “1” in I²C mode.

Table 1.16.11. Functions changed by I²C mode select bit 2

	Function	IICM2 = 0	IICM2 = 1
1	Factor of interrupt number 15	No acknowledgment detection (NACK)	UART2 transmission (the rising edge of the final bit of the clock)
2	Factor of interrupt number 16	Acknowledgment detection (ACK)	UART2 reception (the falling edge of the final bit of the clock)
3	Timing for transferring data from the UART2 reception shift register to the reception buffer.	The rising edge of the final bit of the reception clock	The falling edge of the final bit of the reception clock
4	Timing for generating a UART2 reception/ACK interrupt request	The rising edge of the final bit of the reception clock	The falling edge of the final bit of the reception clock

Table 1.16.12. Timing characteristics of detecting the start condition and the stop condition (Note 1)

3 to 6 cycles < duration for setting-up (Note 2)
3 to 6 cycles < duration for holding (Note 2)

Note 1 : When the start/stop condition control bit SHTC is “1” .

Note 2 : “Cycles” is in terms of the input oscillation frequency f(XIN) of the main clock.

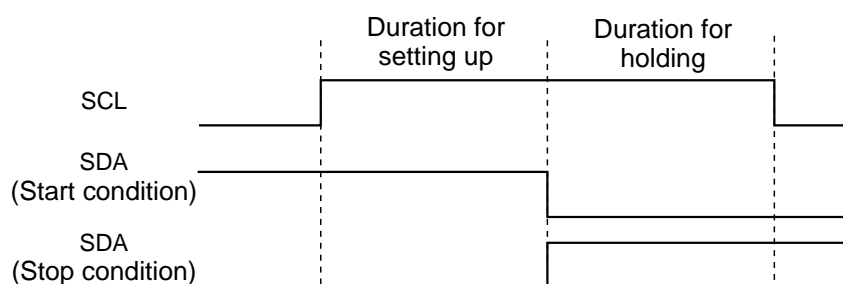

UART2 Special Mode Register 2

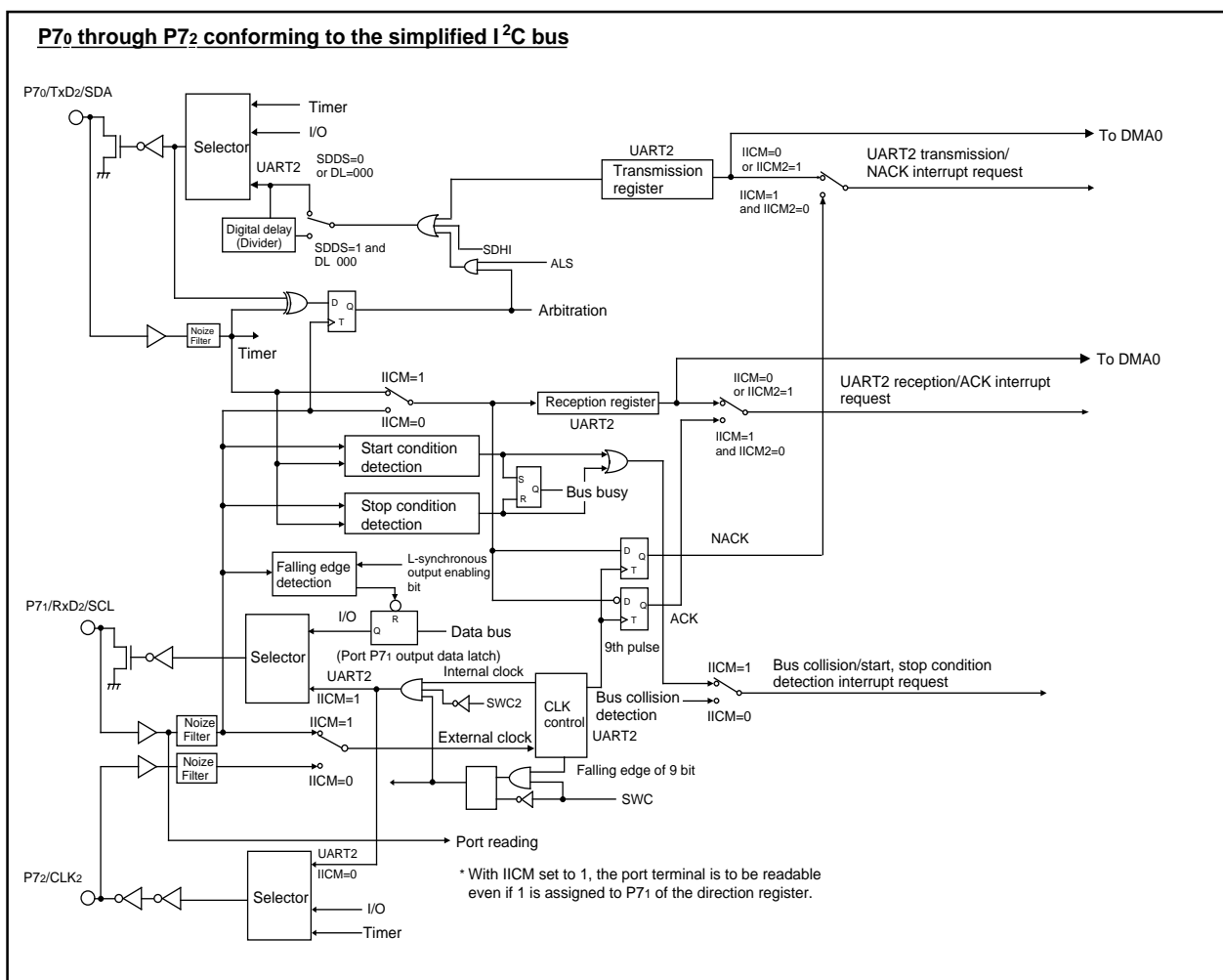

Figure 1.16.30. Functional block diagram for I²C mode

Functions available in I²C mode are shown in Figure 1.16.30 — a functional block diagram.

Bit 3 of the UART2 special mode register 2 (address 0376₁₆) is used as the SDA output stop bit. Setting this bit to “1” causes an arbitration loss to occur, and the SDA pin turns to high-impedance state at the instant when the arbitration lost detecting flag is set to “1”.

Bit 1 of the UART2 special mode register 2 (address 0376₁₆) is used as the clock synchronization bit. With this bit set to “1” at the time when the internal SCL is set to “H”, the internal SCL turns to “L” if the falling edge is found in the SCL pin; and the baud rate generator reloads the set value, and start counting within the “L” interval. When the internal SCL changes from “L” to “H” with the SCL pin set to “L”, stops counting the baud rate generator, and starts counting it again when the SCL pin turns to “H”. Due to this function, the UART2 transmission-reception clock becomes the logical product of the signal flowing through the internal SCL and that flowing through the SCL pin. This function operates over the period from the moment earlier by a half cycle than falling edge of the UART2 first clock to the rising edge of the ninth bit. To use this function, choose the internal clock for the transfer clock.

Bit 2 of the UART2 special mode register 2 (0376₁₆) is used as the SCL wait output bit. Setting this bit to “1” causes the SCL pin to be fixed to “L” at the falling edge of the ninth bit of the clock. Setting this bit to “0” frees the output fixed to “L”.

Bit 4 of the UART2 special mode register 2 (address 0376₁₆) is used as the UART2 initialization bit. Setting this bit to “1”, and when the start condition is detected, the microcomputer operates as follows.

- (1) The transmission shift register is initialized, and the content of the transmission register is transferred to the transmission shift register. This starts transmission by dealing with the clock entered next as the first bit. The UART2 output value, however, doesn't change until the first bit data is output after the entrance of the clock, and remains unchanged from the value at the moment when the microcomputer detected the start condition.
- (2) The reception shift register is initialized, and the microcomputer starts reception by dealing with the clock entered next as the first bit.
- (3) The SCL wait output bit turns to “1”. This turns the SCL pin to “L” at the falling edge of the ninth bit of the clock.

Starting to transmit/receive signals to/from UART2 using this function doesn't change the value of the transmission buffer empty flag. To use this function, choose the external clock for the transfer clock.

Bit 5 of the UART2 special mode register 2 (0376₁₆) is used as the SCL wait output bit 2. Setting this bit to “1” with the serial I/O specified allows the user to forcibly output an “1” from the SCL pin even if UART2 is in operation. Setting this bit to “0” frees the “L” output from the SCL pin, and the UART2 clock is input/output.

Bit 6 of the UART2 special mode register 2 (0376₁₆) is used as the SDA output disable bit. Setting this bit to “1” forces the SDA pin to turn to the high-impedance state. Refrain from changing the value of this bit at the rising edge of the UART2 transfer clock. There can be instances in which arbitration lost detecting flag is turned on.

A-D Converter

A-D Converter

The A-D converter consists of one 10-bit successive approximation A-D converter circuit with a capacitive coupling amplifier. Pins P10₀ to P10₇, P9₅, and P9₆ also function as the analog signal input pins. The direction registers of these pins for A-D conversion must therefore be set to input. The Vref connect bit (bit 5 at address 03D716) can be used to isolate the resistance ladder of the A-D converter from the reference voltage input pin (VREF) when the A-D converter is not used. Doing so stops any current flowing into the resistance ladder from VREF, reducing the power dissipation. When using the A-D converter, start A-D conversion only after setting bit 5 of 03D716 to connect VREF. The result of A-D conversion is stored in the A-D registers of the selected pins. When set to 10-bit precision, the low 8 bits are stored in the even addresses and the high 2 bits in the odd addresses. When set to 8-bit precision, the low 8 bits are stored in the even addresses.

Table 1.17.1 shows the performance of the A-D converter. Figure 1.17.1 shows the block diagram of the A-D converter, and Figures 1.17.2 and 1.17.3 show the A-D converter-related registers.

Table 1.17.1. Performance of A-D converter

Item	Performance
Method of A-D conversion	Successive approximation (capacitive coupling amplifier)
Analog input voltage (Note 1)	0V to AVCC (VCC)
Operating clock ϕ_{AD} (Note 2)	$VCC = 3.3V$ $f_{AD}/\text{divide-by-2}$ of $f_{AD}/\text{divide-by-4}$ of f_{AD} , $f_{AD}=f(XIN)$
Resolution	8-bit or 10-bit (selectable)
Absolute precision	$VCC = 3.3V$ <ul style="list-style-type: none"> • Without sample and hold function $\pm 5\text{LSB}$ • With sample and hold function (8-bit resolution) $\pm 2\text{LSB}$ • With sample and hold function (10-bit resolution) AN₀ to AN₇ input : $\pm 5\text{LSB}$ ANEX₀ and ANEX₁ input (including mode in which external operation amp is connected) : $\pm 7\text{LSB}$
Operating modes	One-shot mode
Analog input pins	8pins (AN ₀ to AN ₇) + 2pins (ANEX ₀ and ANEX ₁)
A-D conversion start condition	<ul style="list-style-type: none"> • Software trigger A-D conversion starts when the A-D conversion start flag changes to "1" • External trigger (can be retriggered) A-D conversion starts when the A-D conversion start flag is "1" and the ADTRG/P9₇ input changes from "H" to "L"
Conversion speed per pin	<ul style="list-style-type: none"> • Without sample and hold function 8-bit resolution: 49 ϕ_{AD} cycles, 10-bit resolution: 59 ϕ_{AD} cycles • With sample and hold function 8-bit resolution: 28 ϕ_{AD} cycles, 10-bit resolution: 33 ϕ_{AD} cycles

Note 1: Does not depend on use of sample and hold function.

Note 2: Divide the f_{AD} if $f(XIN)$ exceeds 10MHz, and make ϕ_{AD} frequency equal to or less than 10MHz. And divide the f_{AD} if VCC is less than 3.0V, and make ϕ_{AD} frequency equal to or lower than $f_{AD}/2$.

Without sample and hold function, set the ϕ_{AD} frequency to 250kHz min.

With the sample and hold function, set the ϕ_{AD} frequency to 1MHz min.

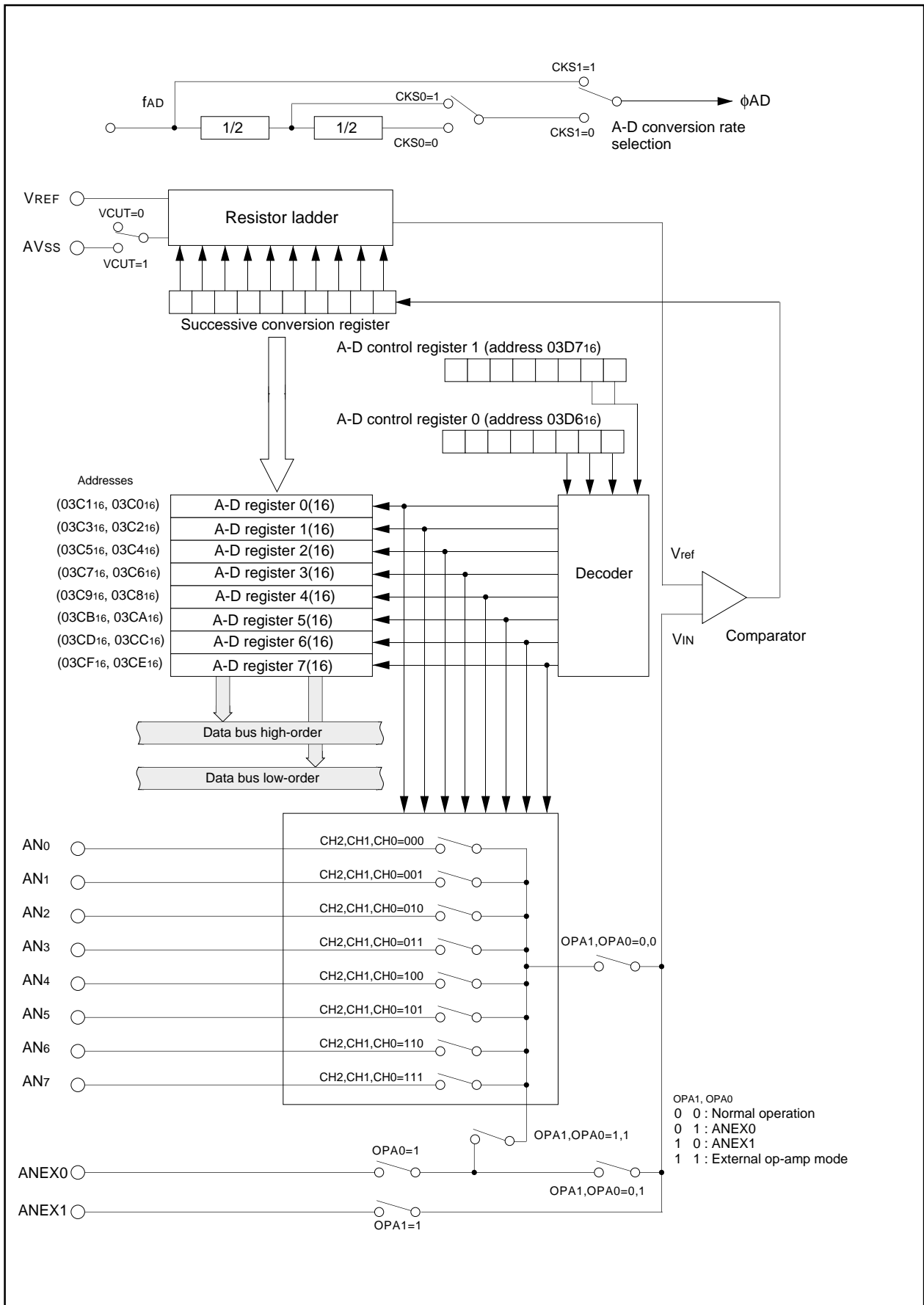

Figure 1.17.1. Block diagram of A-D converter

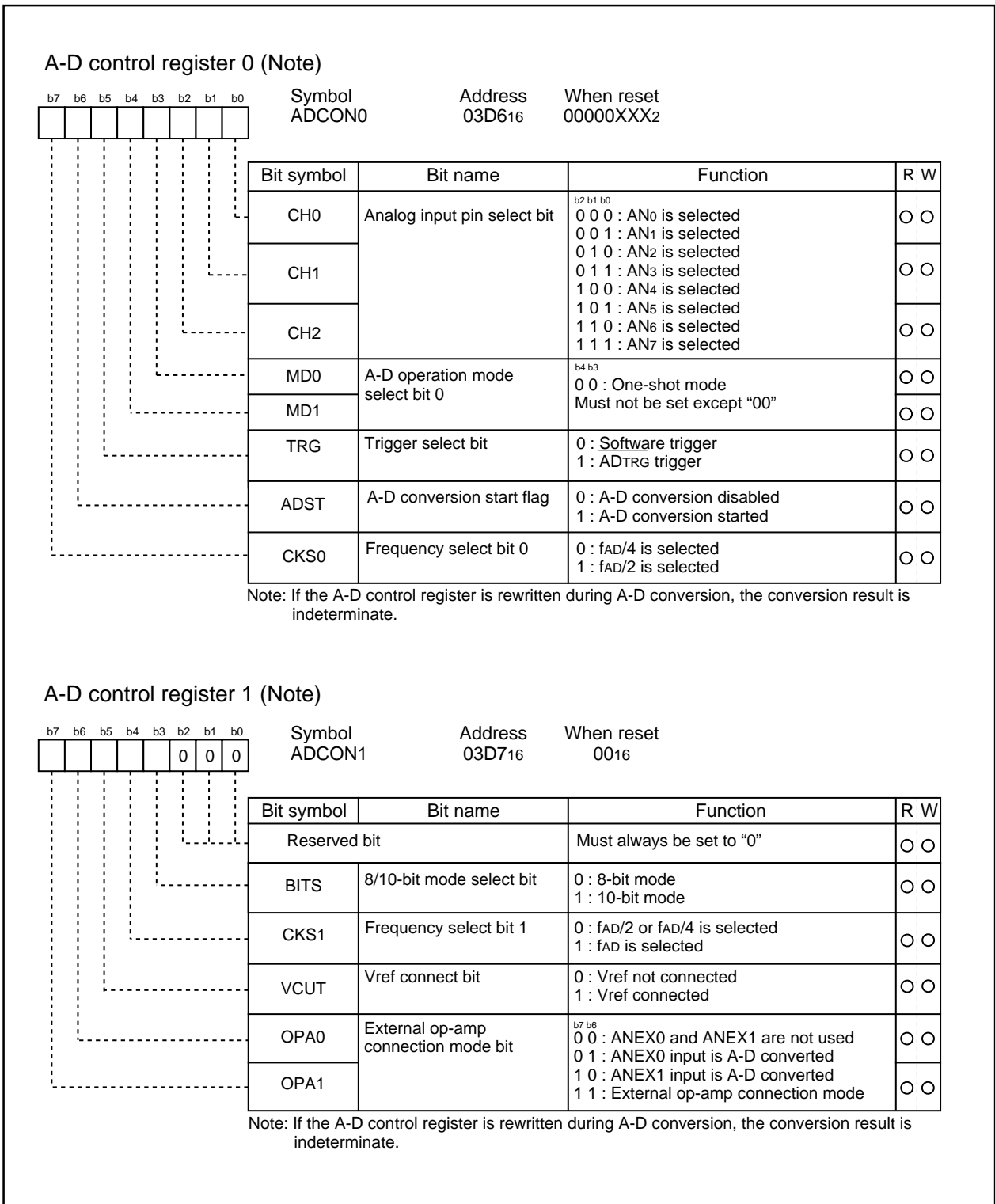

Figure 1.17.2. A-D converter-related registers (1)

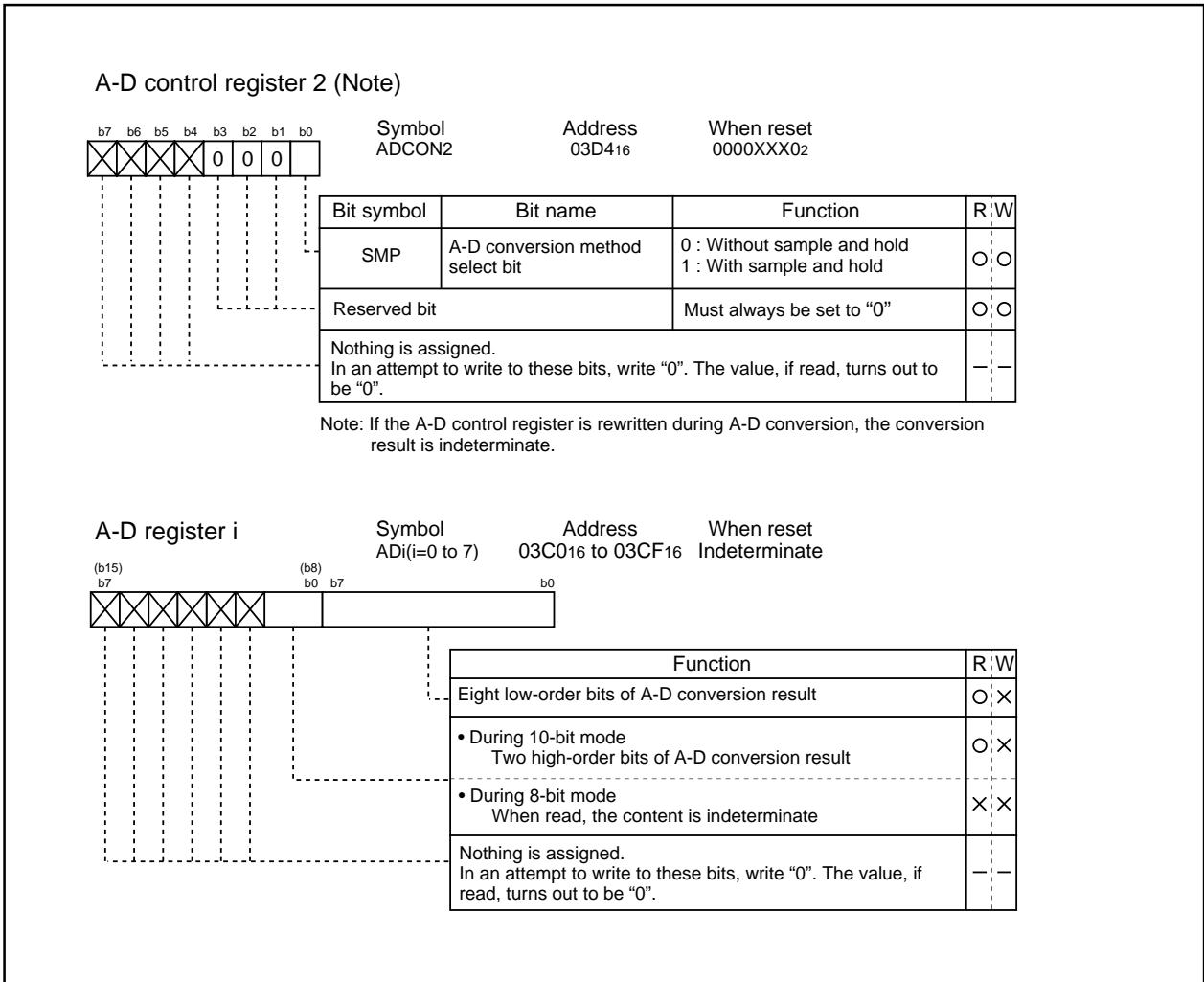

Figure 1.17.3. A-D converter-related registers (2)

(1) One-shot mode

In one-shot mode, the pin selected using the analog input pin select bit is used for one-shot A-D conversion. Table 1.17.2 shows the specifications of one-shot mode. Figure 1.17.4 shows the A-D control register in one-shot mode.

Table 1.17.2. One-shot mode specifications

Item	Specification
Function	The pin selected by the analog input pin select bit is used for one A-D conversion
Start condition	Writing "1" to A-D conversion start flag
Stop condition	<ul style="list-style-type: none"> End of A-D conversion (A-D conversion start flag changes to "0", except when external trigger is selected) Writing "0" to A-D conversion start flag
Interrupt request generation timing	End of A-D conversion
Input pin	One of AN0 to AN7, as selected
Reading of result of A-D converter	Read A-D register corresponding to selected pin

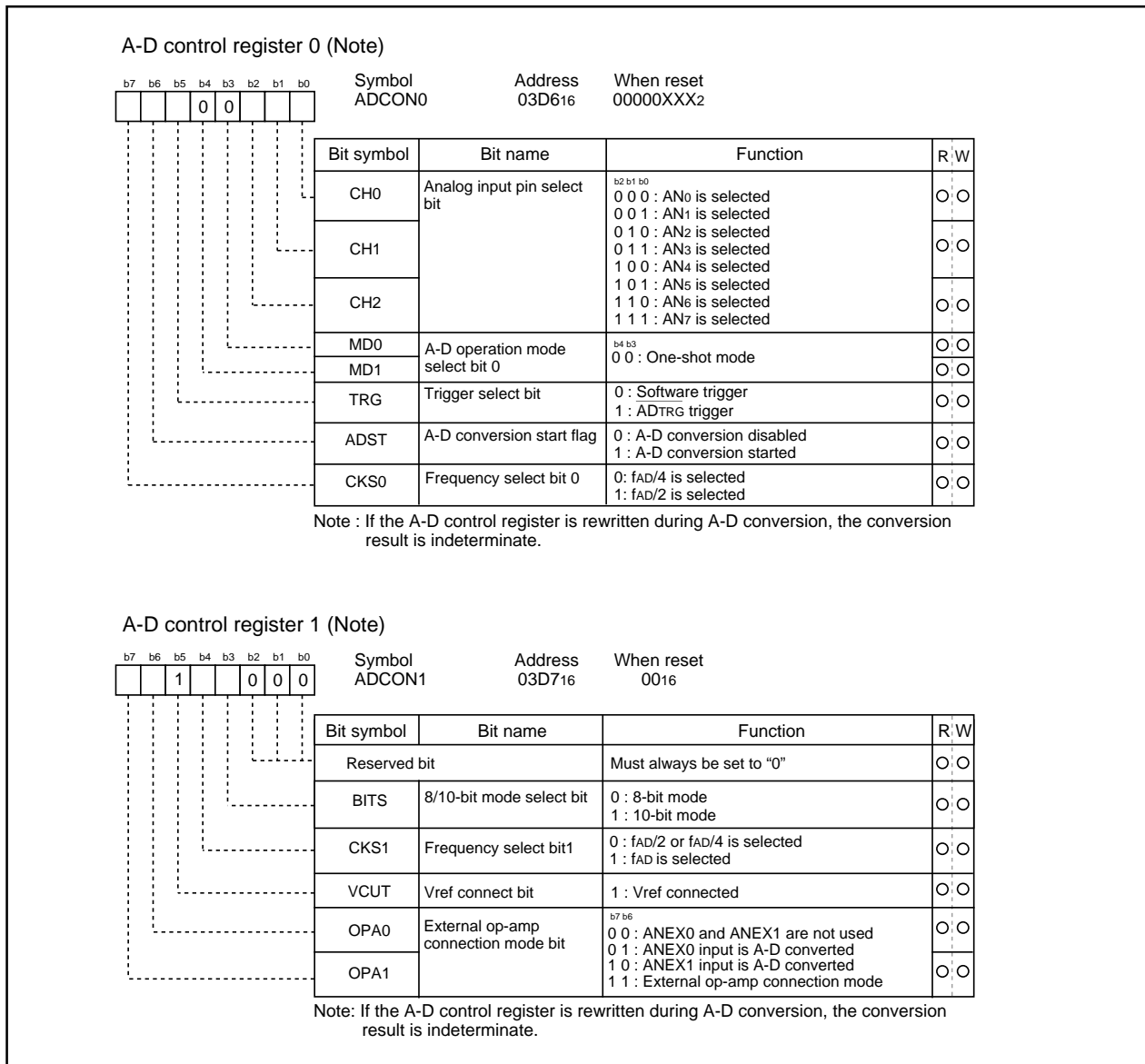

Figure 1.17.4. A-D conversion register in one-shot mode

(a) Sample and hold

Sample and hold is selected by setting bit 0 of the A-D control register 2 (address 03D416) to "1". When sample and hold is selected, the rate of conversion of each pin increases. As a result, a $28 \phi_{AD}$ cycle is achieved with 8-bit resolution and $33 \phi_{AD}$ with 10-bit resolution. Sample and hold can be selected in all modes. However, in all modes, be sure to specify before starting A-D conversion whether sample and hold is to be used.

(b) Extended analog input pins

In one-shot mode and repeat mode, the input via the extended analog input pins ANEX0 and ANEX1 can also be converted from analog to digital.

When bit 6 of the A-D control register 1 (address 03D716) is "1" and bit 7 is "0", input via ANEX0 is converted from analog to digital. The result of conversion is stored in A-D register 0.

When bit 6 of the A-D control register 1 (address 03D716) is "0" and bit 7 is "1", input via ANEX1 is converted from analog to digital. The result of conversion is stored in A-D register 1.

(c) External operation amp connection mode

In this mode, multiple external analog inputs via the extended analog input pins, ANEX0 and ANEX1, can be amplified together by just one operation amp and used as the input for A-D conversion.

When bit 6 of the A-D control register 1 (address 03D716) is "1" and bit 7 is "1", input via AN0 to AN7 is output from ANEX0. The input from ANEX1 is converted from analog to digital and the result stored in the corresponding A-D register. The speed of A-D conversion depends on the response of the external operation amp. Do not connect the ANEX0 and ANEX1 pins directly. Figure 1.17.5 is an example of how to connect the pins in external operation amp mode.

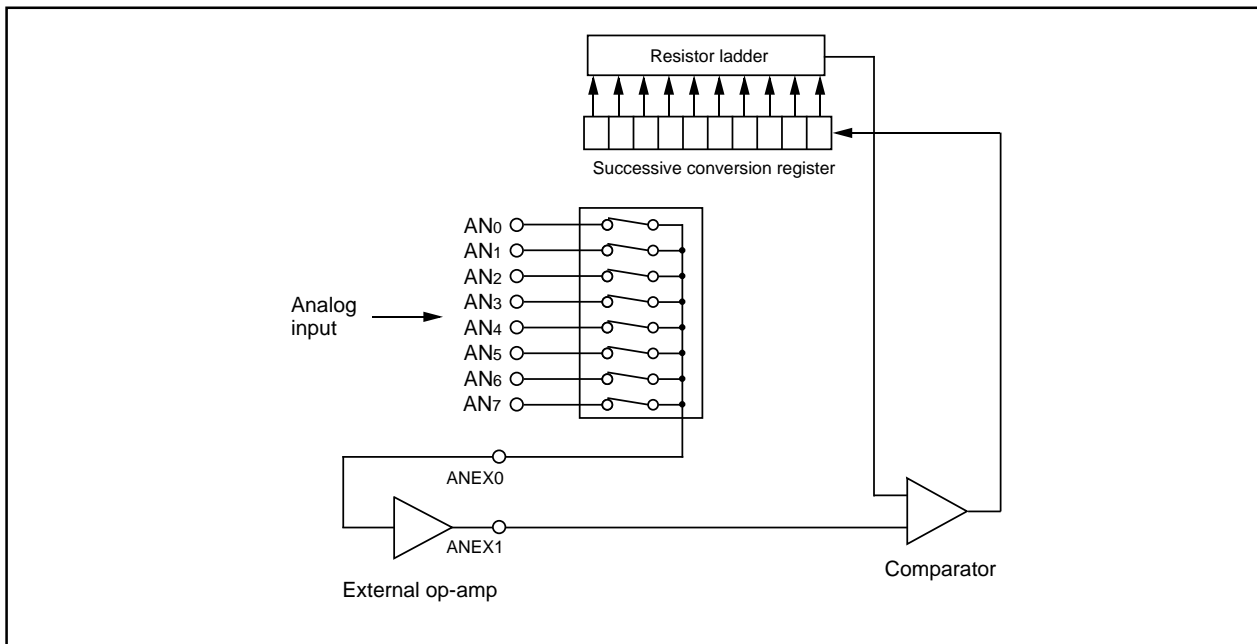

Figure 1.17.5. Example of external op-amp connection mode

Programmable I/O Ports

There are 87 programmable I/O ports: P0 to P10 (excluding P85). Each port can be set independently for input or output using the direction register. A pull-up resistance for each block of 4 ports can be set. P85 is an input-only port and has no built-in pull-up resistance.

Figures 1.20.1 to 1.20.4 show the programmable I/O ports. Figure 1.20.5 shows the I/O pins.

Each pin functions as a programmable I/O port and as the I/O for the built-in peripheral devices.

To use the pins as the inputs for the built-in peripheral devices, set the direction register of each pin to input mode. When the pins are used as the outputs for the built-in peripheral devices (other than the D-A converter), they function as outputs regardless of the contents of the direction registers. When pins are to be used as the outputs for the D-A converter, do not set the direction registers to output mode. See the descriptions of the respective functions for how to set up the built-in peripheral devices.

(1) Direction registers

Figure 1.20.6 shows the direction registers.

These registers are used to choose the direction of the programmable I/O ports. Each bit in these registers corresponds one for one to each I/O pin.

In memory expansion and microprocessor mode, the contents of corresponding direction register of pins A0 to A19, D0 to D15, $\overline{CS0}$ to $\overline{CS3}$, \overline{RD} , $\overline{WRL/WR}$, $\overline{WRH/BHE}$, ALE, \overline{RDY} , \overline{HOLD} , \overline{HLDA} and BCLK cannot be modified.

Note: There is no direction register bit for P85.

(2) Port registers

Figure 1.20.7 shows the port registers.

These registers are used to write and read data for input and output to and from an external device. A port register consists of a port latch to hold output data and a circuit to read the status of a pin. Each bit in port registers corresponds one for one to each I/O pin.

In memory expansion and microprocessor mode, the contents of corresponding port register of pins A0 to A19, D0 to D15, $\overline{CS0}$ to $\overline{CS3}$, \overline{RD} , $\overline{WRL/WR}$, $\overline{WRH/BHE}$, ALE, \overline{RDY} , \overline{HOLD} , \overline{HLDA} and BCLK cannot be modified.

(3) Pull-up control registers

Figure 1.20.8 shows the pull-up control registers.

The pull-up control register can be set to apply a pull-up resistance to each block of 4 ports. When ports are set to have a pull-up resistance, the pull-up resistance is connected only when the direction register is set for input.

However, in memory expansion mode and microprocessor mode, the pull-up control register of P0 to P3, P40 to P43, and P5 is invalid. The contents of register can be changed, but the pull-up resistance is not connected.

(4) Port control register

Figure 1.20.9 shows the port control register.

The bit 0 of port control register is used to read port P1 as follows:

0 : When port P1 is input port, port input level is read.

When port P1 is output port, the contents of port P1 register is read.

1 : The contents of port P1 register is read always.

This register is valid in the following:

- External bus width is 8 bits in microprocessor mode or memory expansion mode.
- Port P1 can be used as a port in multiplexed bus for the entire space.

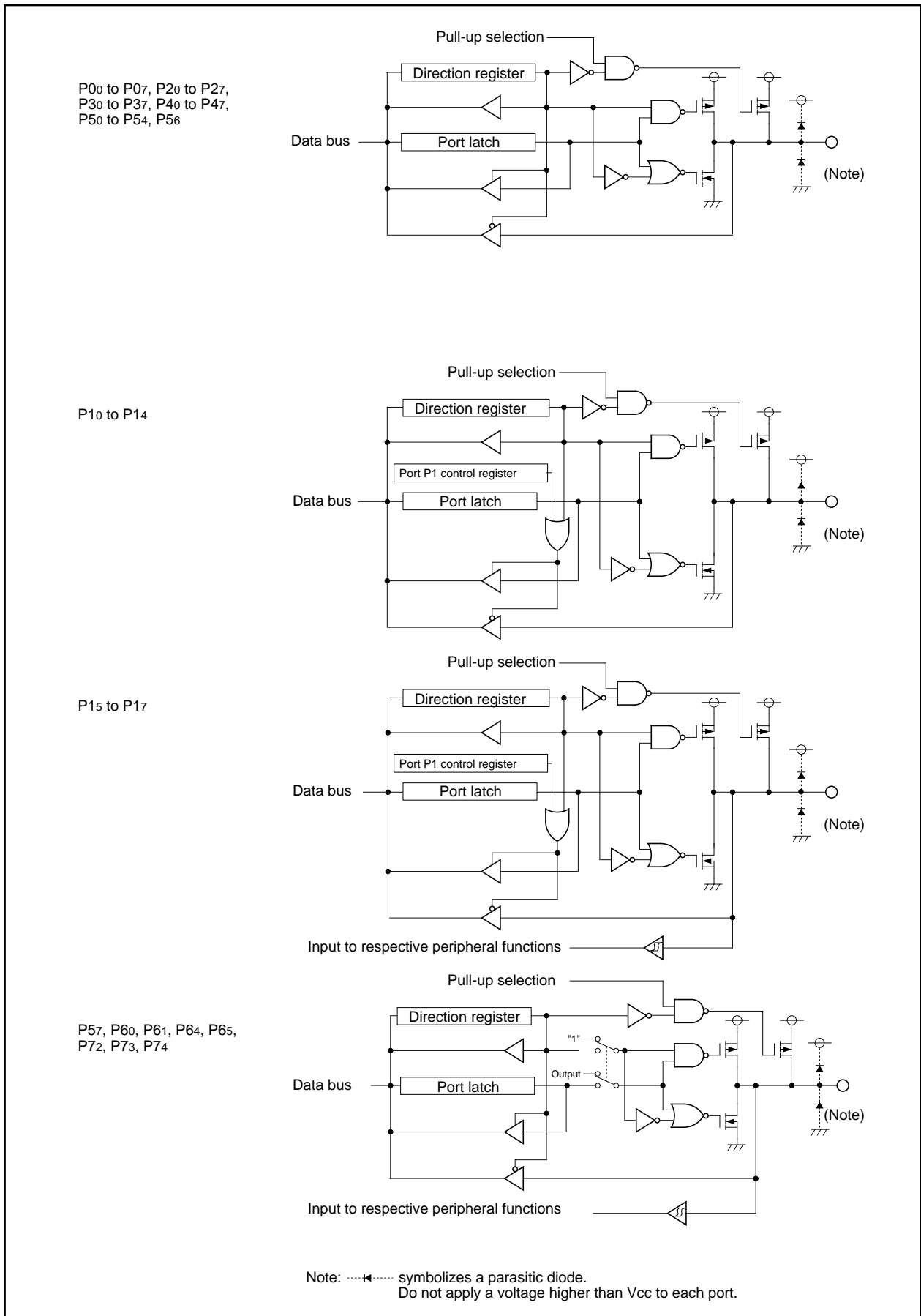

Figure 1.20.1. Programmable I/O ports (1)

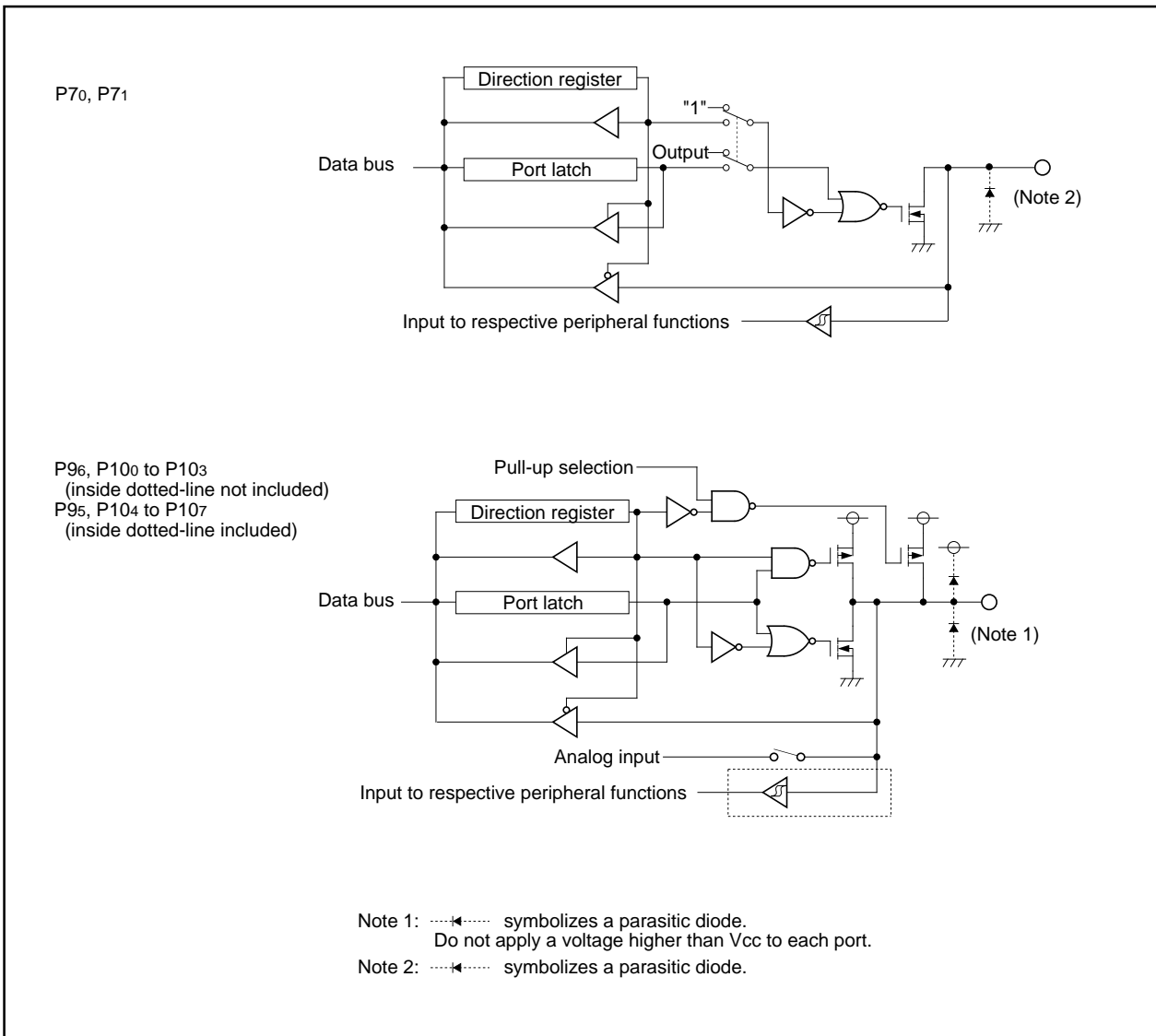

Figure 1.20.3. Programmable I/O ports (3)

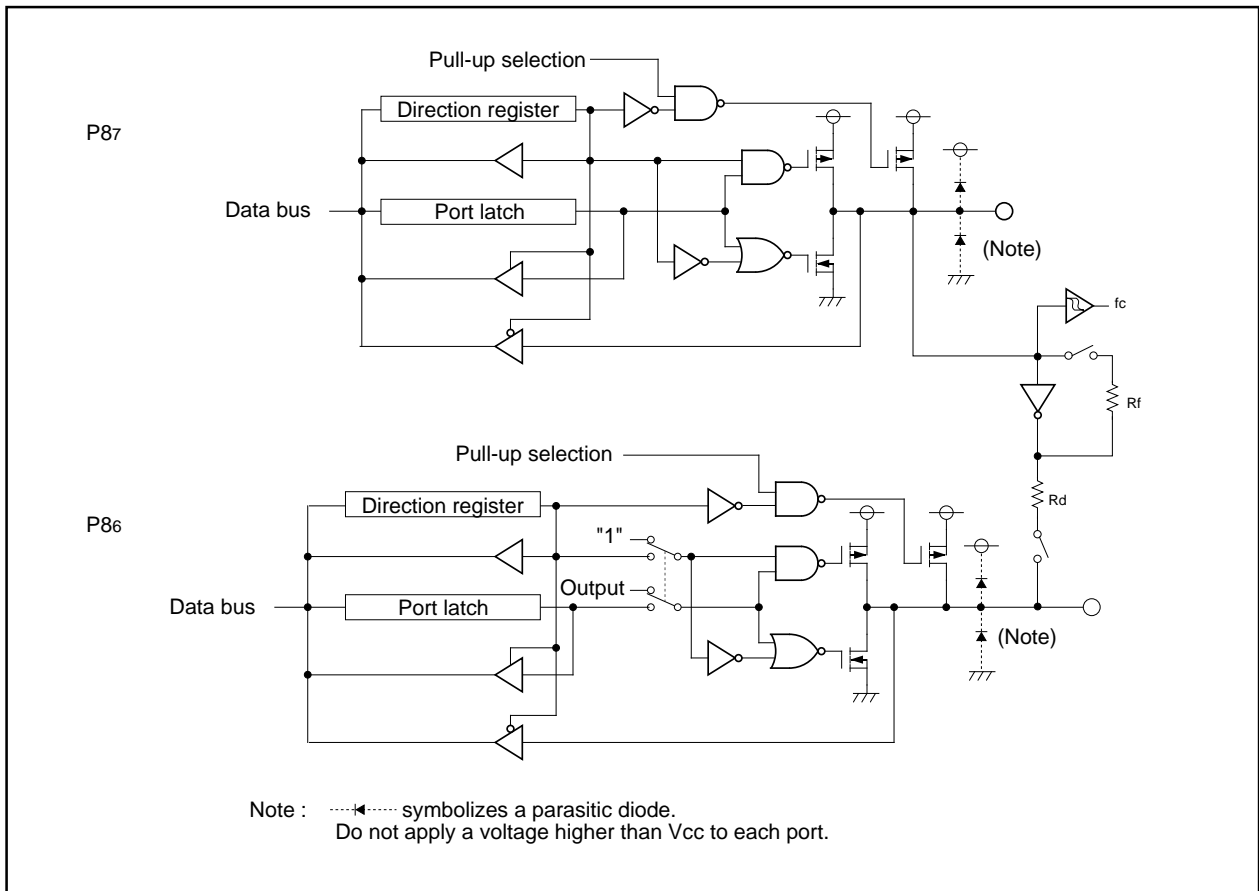

Figure 1.20.4. Programmable I/O ports (4)

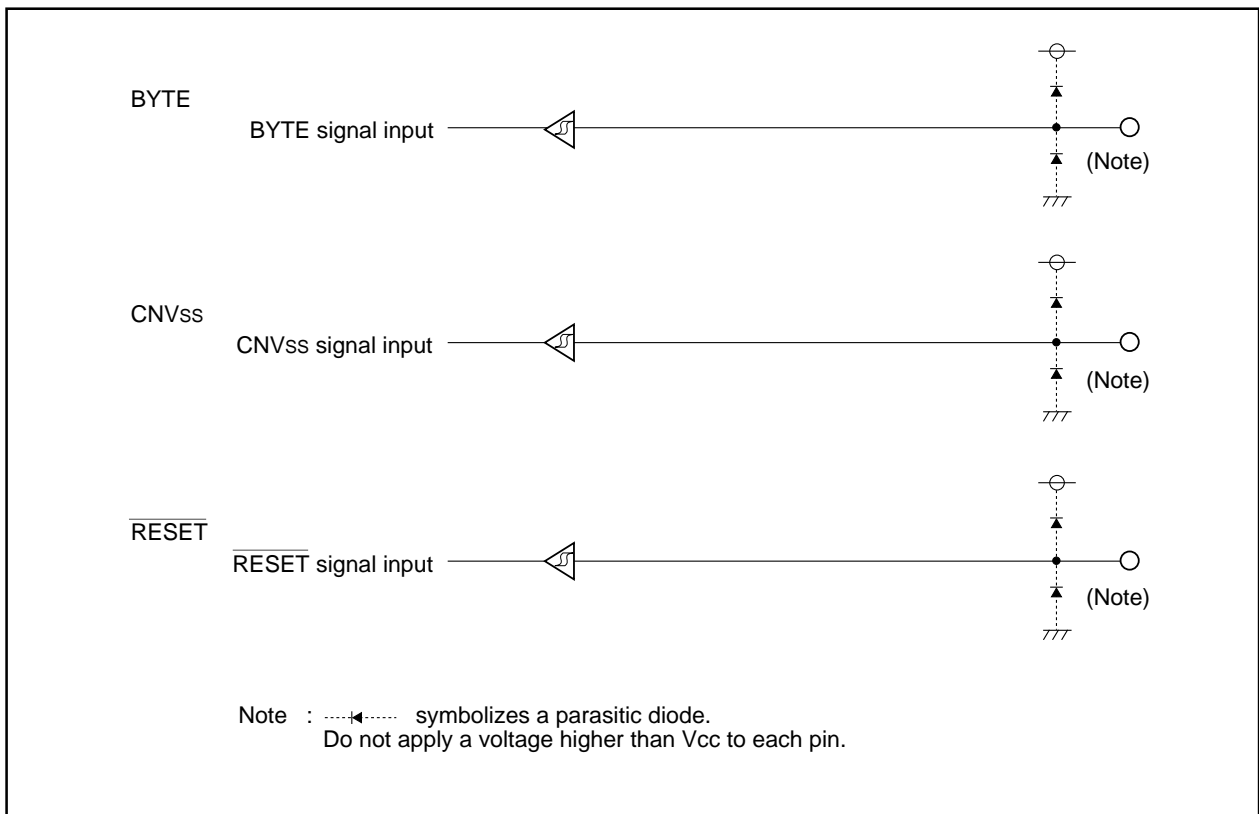

Figure 1.20.5. I/O pins

Programmable I/O Port

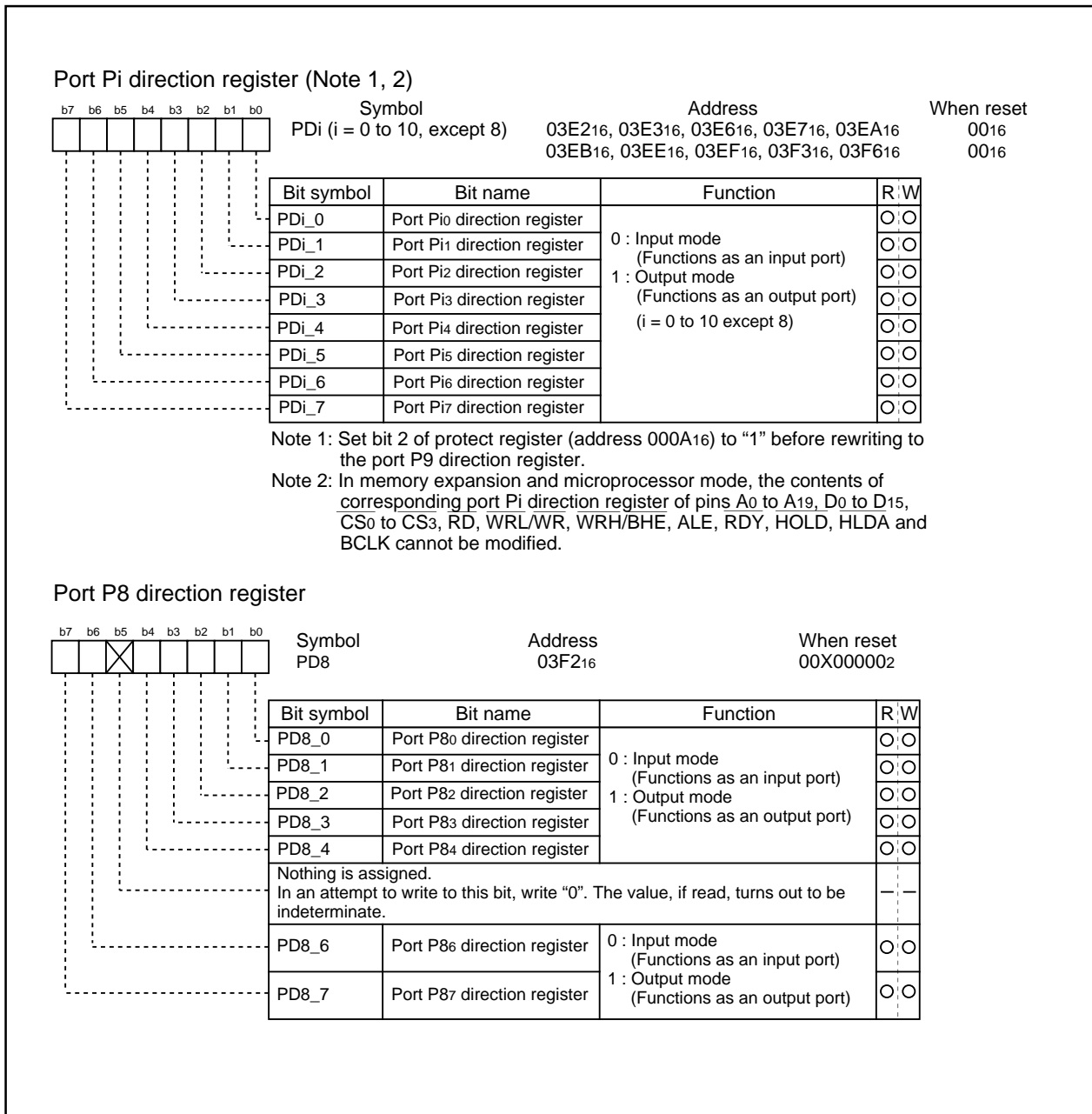

Figure 1.20.6. Direction register

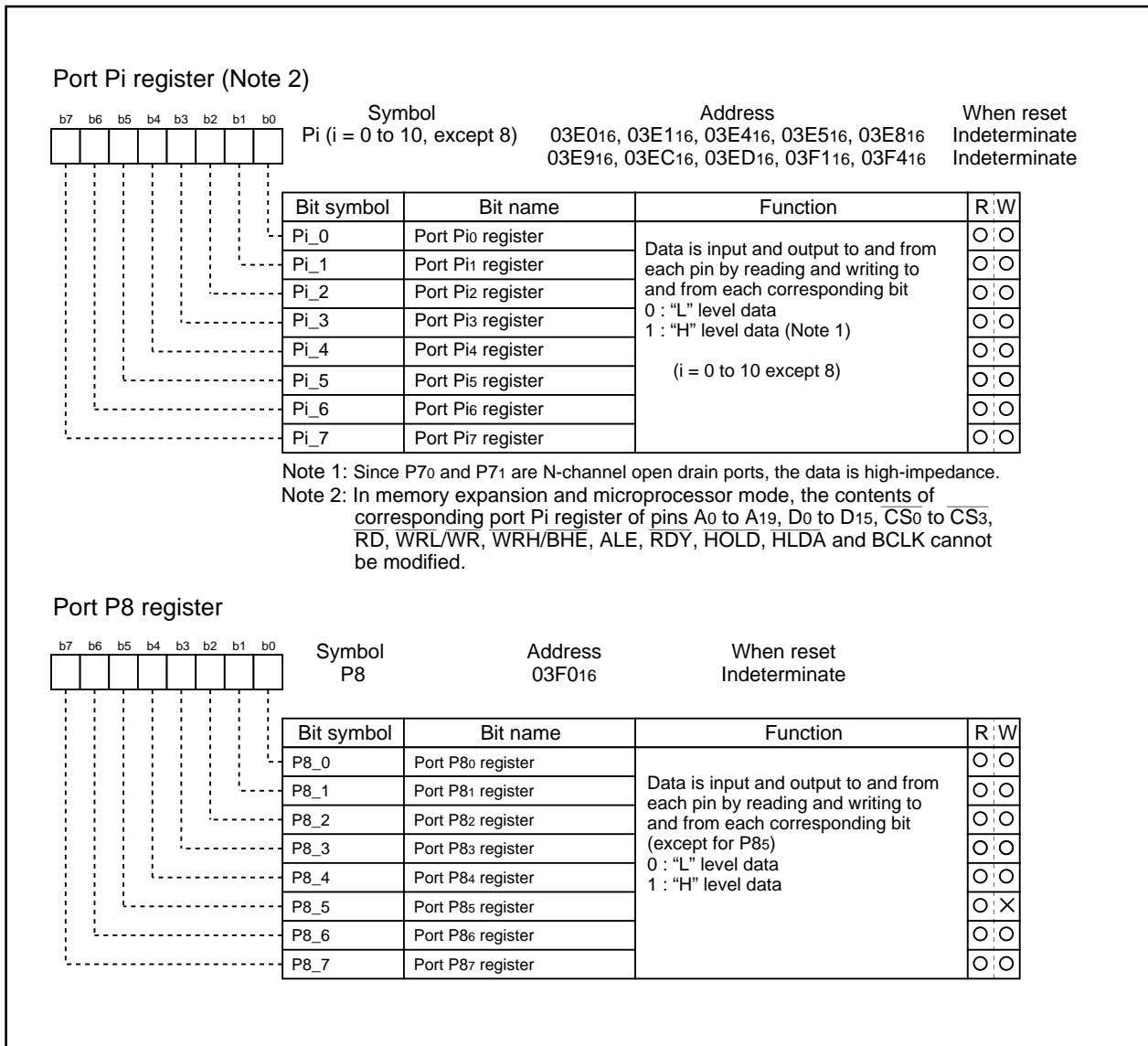
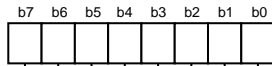

Figure 1.20.7. Port register

Pull-up control register 0 (Note)



Symbol
PUR0

Address
03FC₁₆

When reset
00₁₆

Bit symbol	Bit name	Function	R	W
PU00	P00 to P03 pull-up	The corresponding port is pulled high with a pull-up resistor 0 : Not pulled high 1 : Pulled high	○	○
PU01	P04 to P07 pull-up		○	○
PU02	P10 to P13 pull-up		○	○
PU03	P14 to P17 pull-up		○	○
PU04	P20 to P23 pull-up		○	○
PU05	P24 to P27 pull-up		○	○
PU06	P30 to P33 pull-up		○	○
PU07	P34 to P37 pull-up		○	○

Note : In memory expansion and microprocessor mode, the content of this register can be changed, but the pull-up resistance is not connected.

Pull-up control register 1

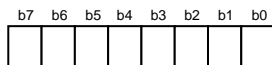

Symbol
PUR1

Address
03FD₁₆

When reset
00₁₆ (Note 2)

Bit symbol	Bit name	Function	R	W
PU10	P40 to P43 pull-up (Note 3)	The corresponding port is pulled high with a pull-up resistor 0 : Not pulled high 1 : Pulled high	○	○
PU11	P44 to P47 pull-up		○	○
PU12	P50 to P53 pull-up (Note 3)		○	○
PU13	P54 to P57 pull-up (Note 3)		○	○
PU14	P60 to P63 pull-up		○	○
PU15	P64 to P67 pull-up		○	○
PU16	P72 to P73 pull-up (Note 1)		○	○
PU17	P74 to P77 pull-up		○	○

Note 1: Since P70 and P71 are N-channel open drain ports, pull-up is not available for them.

Note 2: When the Vcc level is being impressed to the CNVss terminal, this register becomes to 02₁₆ when reset (PU11 becomes to "1").

Note 3: In memory expansion and microprocessor mode, the content of these bits can be changed, but the pull-up resistance is not connected.

Pull-up control register 2

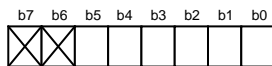

Symbol
PUR2

Address
03FE₁₆

When reset
00₁₆

Bit symbol	Bit name	Function	R	W
PU20	P80 to P83 pull-up	The corresponding port is pulled high with a pull-up resistor 0 : Not pulled high 1 : Pulled high	○	○
PU21	P84 to P87 pull-up (Except P85)		○	○
PU22	P90 to P93 pull-up		○	○
PU23	P94 to P97 pull-up		○	○
PU24	P100 to P103 pull-up		○	○
PU25	P104 to P107 pull-up		○	○
Nothing is assigned. In an attempt to write to these bits, write "0". The value, if read, turns out to be "0".			—	—

Figure 1.20.8. Pull-up control register

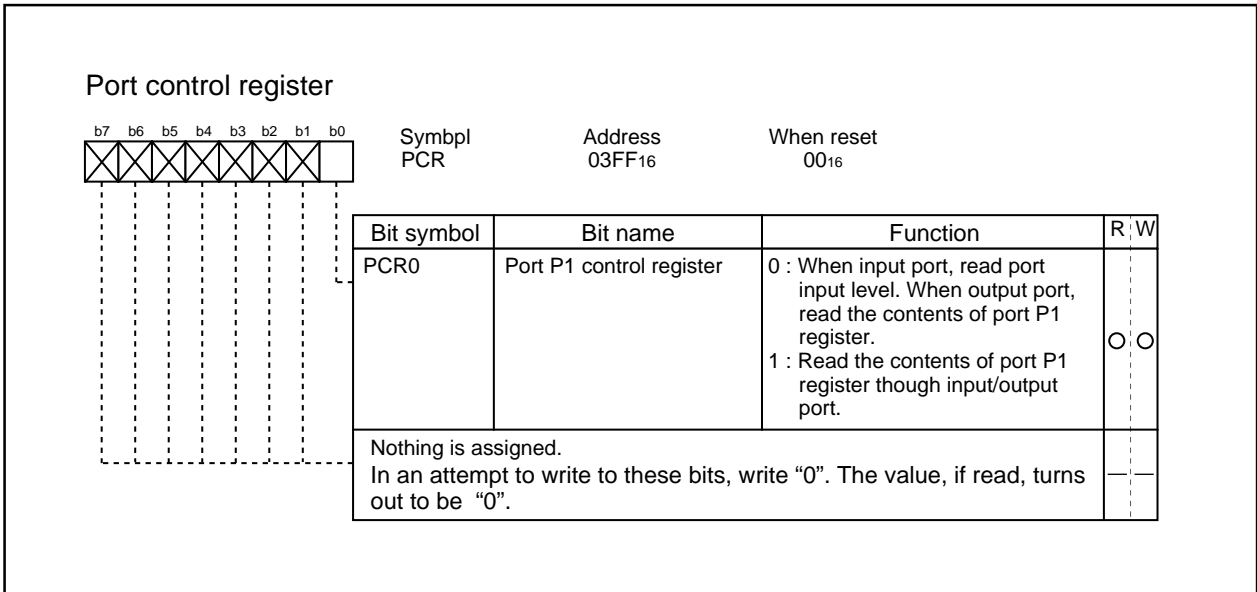

Figure 1.20.9. Port control register

Table 1.20.1. Example connection of unused pins in single-chip mode

Pin name	Connection
Ports P0 to P10 (excluding P85)	After setting for input mode, connect every pin to VSS via a resistor (pull-down); or after setting for output mode, leave these pins open.
XOUT (Note)	Open
$\overline{\text{NMI}}$	Connect via resistor to VCC (pull-up)
AVCC	Connect to VCC
AVSS, VREF, BYTE	Connect to VSS

Note: With external clock input to XIN pin.

Table 1.20.2. Example connection of unused pins in memory expansion mode and microprocessor mode

Pin name	Connection
Ports P6 to P10 (excluding P85)	After setting for input mode, connect every pin to VSS via a resistor (pull-down); or after setting for output mode, leave these pins open.
P45 / $\overline{\text{CS1}}$ to P47 / $\overline{\text{CS3}}$	Set ports to input mode, set output enable bits of $\overline{\text{CS1}}$ through $\overline{\text{CS3}}$ to 0, and connect to Vcc via resistors (pull-up).
$\overline{\text{BHE}}$, ALE, $\overline{\text{HLDA}}$, XOUT (Note 1), BCLK (Note 2)	Open
$\overline{\text{HOLD}}$, RDY, $\overline{\text{NMI}}$	Connect via resistor to VCC (pull-up)
AVCC	Connect to VCC
AVSS, VREF	Connect to VSS

Note 1: With external clock input to XIN pin.

Note 2: When the BCLK output disable bit (bit 7 at address 000416) is set to "1", connect to VCC via a resistor (pull-up).

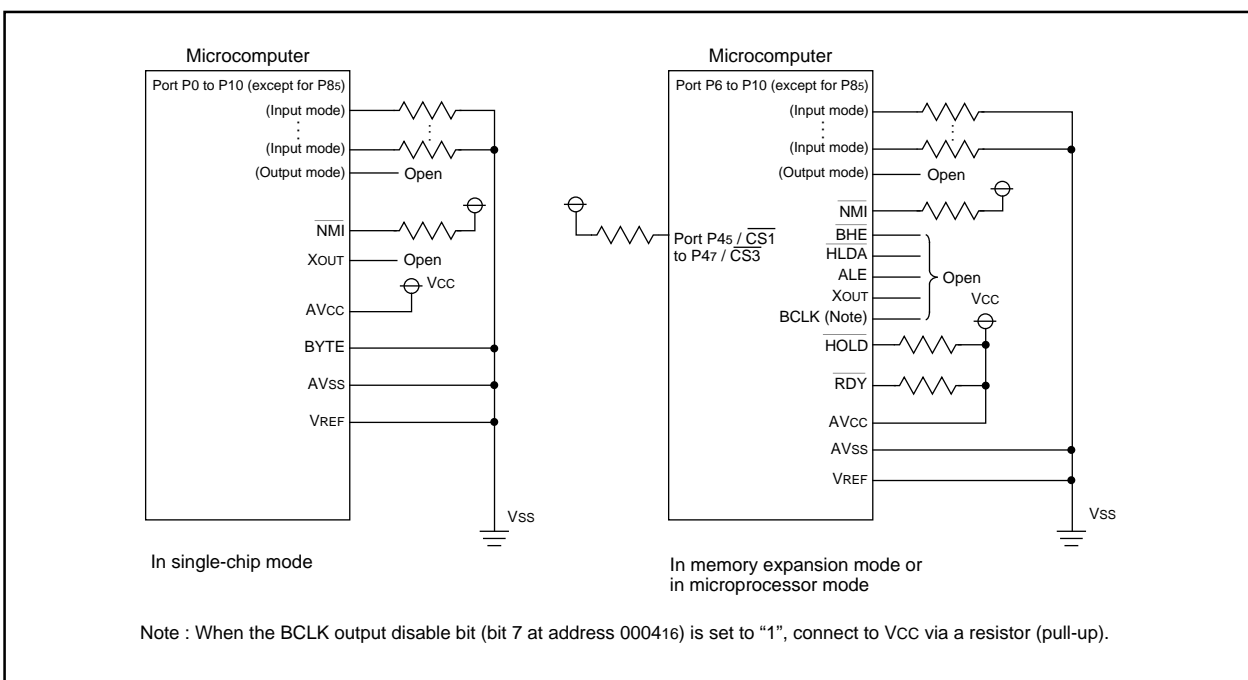

Figure 1.20.10. Example connection of unused pins

Electrical characteristics

Table 1.26.1. Absolute maximum ratings

Symbol	Parameter		Condition	Rated value	Unit
V _{cc}	Supply voltage		V _{cc} =AV _{cc}	- 0.3 to 4.2	V
AV _{cc}	Analog supply voltage		V _{cc} =AV _{cc}	- 0.3 to 4.2	V
V _i	Input voltage	RESET, CNV _{ss} , BYTE, P0 ₀ to P0 ₇ , P1 ₀ to P1 ₇ , P2 ₀ to P2 ₇ , P3 ₀ to P3 ₇ , P4 ₀ to P4 ₇ , P5 ₀ to P5 ₇ , P6 ₀ to P6 ₇ , P7 ₂ to P7 ₇ , P8 ₀ to P8 ₇ , P9 ₀ to P9 ₇ , P10 ₀ to P10 ₇ , VREF, XIN		- 0.3 to V _{cc} + 0.3	V
		P7 ₀ , P7 ₁		- 0.3 to 4.2	V
V _o	Output voltage	P0 ₀ to P0 ₇ , P1 ₀ to P1 ₇ , P2 ₀ to P2 ₇ , P3 ₀ to P3 ₇ , P4 ₀ to P4 ₇ , P5 ₀ to P5 ₇ , P6 ₀ to P6 ₇ , P7 ₂ to P7 ₇ , P8 ₀ to P8 ₄ , P8 ₆ , P8 ₇ , P9 ₀ to P9 ₇ , P10 ₀ to P10 ₇ , XOUT		- 0.3 to V _{cc} + 0.3	V
		P7 ₀ , P7 ₁		- 0.3 to 4.2	V
P _d	Power dissipation		T _{opr} =25 °C	300	mW
T _{opr}	Operating ambient temperature			- 20 to 85 / -40 to 85 (Note)	°C
T _{stg}	Storage temperature			- 65 to 150	°C

Note: Specify a product of -40°C to 85°C to use it.

Electrical characteristics

Table 1.26.2. Recommended operating conditions (referenced to $V_{CC} = 2.2V$ to $3.6V$ at $T_{opr} = -20^{\circ}C$ to $85^{\circ}C$ / $-40^{\circ}C$ to $85^{\circ}C$ (Note 3) unless otherwise specified)

Symbol	Parameter		Standard			Unit
			Min.	Typ.	Max.	
V_{CC}	Supply voltage		2.2	3.3	3.6	V
AV_{CC}	Analog supply voltage			V_{CC}		V
V_{SS}	Supply voltage			0		V
AV_{SS}	Analog supply voltage			0		V
V_{IH}	HIGH input voltage	P31 to P37, P40 to P47, P50 to P57, P60 to P67, P72 to P77, P80 to P87, P90 to P97, P100 to P107, X_{IN} , RESET, CNVSS, BYTE	0.8Vcc		V_{CC}	V
		P70, P71	0.8Vcc		4.2	V
		P00 to P07, P10 to P17, P20 to P27, P30 (during single-chip mode)	0.8Vcc		V_{CC}	V
		P00 to P07, P10 to P17, P20 to P27, P30 (data input function during memory expansion and microprocessor modes)	0.5Vcc		V_{CC}	V
V_{IL}	LOW input voltage	P31 to P37, P40 to P47, P50 to P57, P60 to P67, P70 to P77, P80 to P87, P90 to P97, P100 to P107, X_{IN} , RESET, CNVSS, BYTE	0		0.2Vcc	V
		P00 to P07, P10 to P17, P20 to P27, P30 (during single-chip mode)	0		0.2Vcc	V
		P00 to P07, P10 to P17, P20 to P27, P30 (data input function during memory expansion and microprocessor modes)	0		0.16Vcc	V
I_{OH} (peak)	HIGH peak output current	P00 to P07, P10 to P17, P20 to P27, P30 to P37, P40 to P47, P50 to P57, P60 to P67, P72 to P77, P80 to P84, P86, P87, P90 to P97, P100 to P107			- 10.0	mA
I_{OH} (avg)	HIGH average output current	P00 to P07, P10 to P17, P20 to P27, P30 to P37, P40 to P47, P50 to P57, P60 to P67, P72 to P77, P80 to P84, P86, P87, P90 to P97, P100 to P107			- 5.0	mA
I_{OL} (peak)	LOW peak output current	P00 to P07, P10 to P17, P20 to P27, P30 to P37, P40 to P47, P50 to P57, P60 to P67, P70 to P77, P80 to P84, P86, P87, P90 to P97, P100 to P107			10.0	mA
I_{OL} (avg)	LOW average output current	P00 to P07, P10 to P17, P20 to P27, P30 to P37, P40 to P47, P50 to P57, P60 to P67, P70 to P77, P80 to P84, P86, P87, P90 to P97, P100 to P107			5.0	mA
$f(X_{IN})$	Main clock input oscillation frequency (Note 4)	No wait	$V_{CC}=3.0V$ to $3.6V$	0	16	MHz
			$V_{CC}=2.4V$ to $3.0V$	0	$15 \times V_{CC} - 29$	MHz
			$V_{CC}=2.2V$ to $2.4V$	0	$17.5 \times V_{CC} - 35$	MHz
		With wait	$V_{CC}=3.0V$ to $3.6V$	0	16	MHz
			$V_{CC}=2.4V$ to $3.0V$	0	$11.25 \times V_{CC} - 17.75$	MHz
			$V_{CC}=2.2V$ to $2.4V$	0	$11.25 \times V_{CC} - 17.75$	MHz
$f(X_{CIN})$	Subclock oscillation frequency			32.768	50	kHz

Note 1: The mean output current is the mean value within 100ms.

Note 2: The total I_{OL} (peak) for ports P0, P1, P2, P86, P87, P9, and P10 must be 80mA max. The total I_{OH} (peak) for ports P0, P1, P2, P86, P87, P9, and P10 must be 80mA max. The total I_{OL} (peak) for ports P3, P4, P5, P6, P7, and P80 to P84 must be 80mA max. The total I_{OH} (peak) for ports P3, P4, P5, P6, P72 to P77, and P80 to P84 must be 80mA max.

Note 3: Specify a product of $-40^{\circ}C$ to $85^{\circ}C$ to use it.

Note 4: Relationship between main clock oscillation frequency and supply voltage.

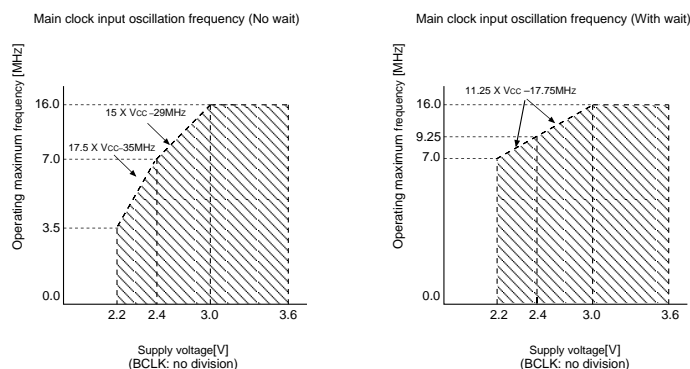

Table 1.26.3. Electrical characteristics (referenced to VCC = 3.0V to 3.6V, VSS = 0V at Topr = -20°C to 85°C / -40°C to 85°C (Note 1), f(XIN) = 16MHz unless otherwise specified)

Symbol	Parameter		Measuring condition	Standard			Unit
				Min	Typ.	Max.	
VOH	HIGH output voltage P00 to P07, P10 to P17, P20 to P27, P30 to P37, P40 to P47, P50 to P57, P60 to P67, P70 to P77, P80 to P84, P86, P87, P90 to P97, P100 to P107		IOH = -1mA VCC = 3.3V	2.8			V
VOH	HIGH output voltage XOUT	HIGHPOWER	IOH = -0.1mA, VCC = 3.3V	2.8			V
		LOWPOWER	IOH = -50µA, VCC = 3.3V	2.8			V
	HIGH output voltage XCOU	HIGHPOWER	With no load applied, VCC = 3.3V		2.8		V
		LOWPOWER	With no load applied, VCC = 3.3V		1.6		V
VOL	LOW output voltage P00 to P07, P10 to P17, P20 to P27, P30 to P37, P40 to P47, P50 to P57, P60 to P67, P70 to P77, P80 to P84, P86, P87, P90 to P97, P100 to P107		IOL = 1mA VCC = 3.3V			0.5	V
VOL	LOW output voltage XOUT	HIGHPOWER	IOL = 0.1mA, VCC = 3.3V			0.5	V
		LOWPOWER	IOL = 50µA, VCC = 3.3V			0.5	V
	LOW output voltage XCOU	HIGHPOWER	With no load applied, VCC = 3.3V		0		V
		LOWPOWER	With no load applied, VCC = 3.3V		0		V
VT+-VT-	Hysteresis	HOLD, RDY, TA0IN to TA2IN, TB1IN, TB2IN, INT0 to INT2, NMI, ADTRG, CTS0 to CTS2, SCL, SDA CLK0 to CLK2, TA2OUT, KI0 to KI3, RxD0 to RxD2	VCC = 3.3V	0.2		0.8	V
VT+-VT-	Hysteresis	RESET	VCC = 3.3V	0.2		1.8	V
IiH	HIGH input current	P00 to P07, P10 to P17, P20 to P27, P30 to P37, P40 to P47, P50 to P57, P60 to P67, P70 to P77, P80 to P87, P90 to P97, P100 to P107, XIN, RESET, CNVss, BYTE	Vi = 3V VCC = 3.3V			4.0	µA
IiL	LOW input current	P00 to P07, P10 to P17, P20 to P27, P30 to P37, P40 to P47, P50 to P57, P60 to P67, P70 to P77, P80 to P87, P90 to P97, P100 to P107, XIN, RESET, CNVss, BYTE	Vi = 0V VCC = 3.3V			-4.0	µA
R PULLUP	Pull-up resistance	P00 to P07, P10 to P17, P20 to P27, P30 to P37, P40 to P47, P50 to P57, P60 to P67, P70 to P77, P80 to P84, P86, P87, P90 to P97, P100 to P107	Vi = 0V VCC = 3.3V	20.0	100.0	500.0	kΩ
R fXIN	Feedback resistance	XIN			3.0		MΩ
R fXCIN	Feedback resistance	XCIN			10.0		MΩ
V RAM	RAM retention voltage		When clock is stopped	2.0			V
Icc	Power supply current		In single-chip mode, the output pins are open and other pins are Vss	f(XIN) = 16MHz, Square wave, no division	12.5	25.0	mA
				f(XCIN) = 32kHz, VCC = 3.3V Square wave	40.0		µA
				f(XCIN) = 32kHz, VCC = 3.3V When a WAIT instruction is executed. Oscillation capacity High (Note 2)	5.8		µA
				f(XCIN) = 32kHz, VCC = 3.3V When a WAIT instruction is executed. Oscillation capacity Low (Note 2)	2.7		µA
				Topr = 25°C, VCC = 3.3V when clock is stopped	0.1	2.0	µA
Topr = 85°C, VCC = 3.3V when clock is stopped	0.4	100					

Note 1: Specify a product of -40°C to 85°C to use it.
Note 2: With one timer operated using fc32.

Electrical characteristics

Table 1.26.4. A-D conversion characteristics (referenced to $V_{CC} = AV_{CC} = V_{REF} = 2.4V$ to $3.6V$, $V_{SS} = AV_{SS} = 0V$, at $T_{opr} = -20^{\circ}C$ to $85^{\circ}C$ / $-40^{\circ}C$ to $85^{\circ}C$ (Note 4), $f(X_{IN}) = 16MHz$ unless otherwise specified)

Symbol	Parameter		Measuring condition	Standard			Unit	
				Min.	Typ.	Max.		
-	Resolution		$V_{REF} = V_{CC}$			10	Bits	
-	Absolute accuracy	Sample & hold function not available	$V_{REF} = V_{CC} = 3.3V$		± 2	± 5	LSB	
		Sample & hold function available(10bit)	$V_{REF} = V_{CC} = 3.3V$	AN0 to AN7 input		± 2	± 5	LSB
				ANEX0, ANEX1 input			± 7	LSB
	Sample & hold function available(8bit)	$V_{REF} = V_{CC} = 3.3V$			± 2	LSB		
R_{LADDER}	Ladder resistance		$V_{REF} = V_{CC}$	10		40	$k\Omega$	
t_{CONV}	Conversion time(10bit)			3.3			μs	
t_{CONV}	Conversion time(8bit)			2.8			μs	
t_{SAMP}	Sampling time			0.3			μs	
V_{REF}	Reference voltage			2.4		V_{CC}	V	
V_{IA}	Analog input voltage			0		V_{REF}	V	

Note 1: Do $f(X_{IN})$ in range of main clock input oscillation frequency prescribed with recommended operating conditions of table 1.26.2. Divide the f_{AD} if $f(X_{IN})$ exceeds 10MHz, and make AD operation clock frequency ($\emptyset AD$) equal to or lower than 10MHz. And divide the f_{AD} if V_{CC} is less than 3.0V, and make AD operation clock frequency ($\emptyset AD$) equal to or lower than $f_{AD}/2$.

Note 2: A case without sample & hold function turn AD operation clock frequency ($\emptyset AD$) into 250 kHz or more in addition to a limit of Note 1.

A case with sample & hold function turn AD operation clock frequency ($\emptyset AD$) into 1MHz or more in addition to a limit of Note 1.

Note 3: Connect AV_{CC} pin to V_{CC} pin and apply the same electric potential.

Note 4: Specify a product of $-40^{\circ}C$ to $85^{\circ}C$ to use it.

Timing requirements(referenced to $V_{CC} = 3.3V$, $V_{SS} = 0V$, at $T_{opr} = -20^{\circ}C$ to $85^{\circ}C$ / $-40^{\circ}C$ to $85^{\circ}C$ (*) unless otherwise specified)* : Specify a product of $-40^{\circ}C$ to $85^{\circ}C$ to use it.**Table 1.26.8. External clock input**

Symbol	Parameter	Standard		Unit
		Min.	Max.	
t_c	External clock input cycle time	62.5		ns
$t_{w(H)}$	External clock input HIGH pulse width	25		ns
$t_{w(L)}$	External clock input LOW pulse width	25		ns
t_r	External clock rise time		15	ns
t_f	External clock fall time		15	ns

Table 1.26.9. Memory expansion and microprocessor modes

Symbol	Parameter	Standard		Unit
		Min.	Max.	
$t_{ac1(RD-DB)}$	Data input access time (no wait)		(Note)	ns
$t_{ac2(RD-DB)}$	Data input access time (with wait)		(Note)	ns
$t_{ac3(RD-DB)}$	Data input access time (when accessing multiplex bus area)		(Note)	ns
$t_{su(DB-RD)}$	Data input setup time	50		ns
$t_{su(RDY-BCLK)}$	RDY input setup time	50		ns
$t_{su(HOLD-BCLK)}$	HOLD input setup time	100		ns
$t_h(RD-DB)$	Data input hold time	0		ns
$t_h(BCLK-RDY)$	RDY input hold time	0		ns
$t_h(BCLK-HOLD)$	HOLD input hold time	0		ns
$t_d(BCLK-HLDA)$	HLDA output delay time		40	ns

Note: Calculated according to the BCLK frequency as follows:

$$t_{ac1(RD-DB)} = \frac{10^9}{f(BCLK) \times 2} - 90 \quad [ns]$$

$$t_{ac2(RD-DB)} = \frac{3 \times 10^9}{f(BCLK) \times 2} - 90 \quad [ns]$$

$$t_{ac3(RD-DB)} = \frac{3 \times 10^9}{f(BCLK) \times 2} - 90 \quad [ns]$$

Timing requirements(referenced to $V_{CC} = 3.3V$, $V_{SS} = 0V$, at $T_{opr} = -20^{\circ}C$ to $85^{\circ}C$ / $-40^{\circ}C$ to $85^{\circ}C$ (*) unless otherwise specified)* : Specify a product of $-40^{\circ}C$ to $85^{\circ}C$ to use it.**Table 1.26.10. Timer A input (counter input in event counter mode)**

Symbol	Parameter	Standard		Unit
		Min.	Max.	
$t_{c(TA)}$	TAiIN input cycle time	100		ns
$t_{w(TAH)}$	TAiIN input HIGH pulse width	40		ns
$t_{w(TAL)}$	TAiIN input LOW pulse width	40		ns

Table 1.26.11. Timer A input (gating input in timer mode)

Symbol	Parameter	Standard		Unit
		Min.	Max.	
$t_{c(TA)}$	TAiIN input cycle time	400		ns
$t_{w(TAH)}$	TAiIN input HIGH pulse width	200		ns
$t_{w(TAL)}$	TAiIN input LOW pulse width	200		ns

Table 1.26.12. Timer A input (external trigger input in one-shot timer mode)

Symbol	Parameter	Standard		Unit
		Min.	Max.	
$t_{c(TA)}$	TAiIN input cycle time	200		ns
$t_{w(TAH)}$	TAiIN input HIGH pulse width	100		ns
$t_{w(TAL)}$	TAiIN input LOW pulse width	100		ns

Table 1.26.13. Timer A input (external trigger input in pulse width modulation mode)

Symbol	Parameter	Standard		Unit
		Min.	Max.	
$t_{w(TAH)}$	TAiIN input HIGH pulse width	100		ns
$t_{w(TAL)}$	TAiIN input LOW pulse width	100		ns

Table 1.26.14. Timer A input (up/down input in event counter mode)

Symbol	Parameter	Standard		Unit
		Min.	Max.	
$t_{c(UP)}$	TAiOUT input cycle time	2000		ns
$t_{w(UPH)}$	TAiOUT input HIGH pulse width	1000		ns
$t_{w(UPL)}$	TAiOUT input LOW pulse width	1000		ns
$t_{su(UP-TiN)}$	TAiOUT input setup time	400		ns
$t_{h(TiN-UP)}$	TAiOUT input hold time	400		ns

Timing requirements(referenced to $V_{CC} = 3.3V$, $V_{SS} = 0V$, at $T_{opr} = -20^{\circ}C$ to $85^{\circ}C$ / $-40^{\circ}C$ to $85^{\circ}C$ (*) unless otherwise specified)* : Specify a product of $-40^{\circ}C$ to $85^{\circ}C$ to use it.**Table 1.26.15. Timer B input (counter input in event counter mode)**

Symbol	Parameter	Standard		Unit
		Min.	Max.	
$t_{c(TB)}$	TBiIN input cycle time (counted on one edge)	100		ns
$t_{w(TBH)}$	TBiIN input HIGH pulse width (counted on one edge)	40		ns
$t_{w(TBL)}$	TBiIN input LOW pulse width (counted on one edge)	40		ns
$t_{c(TB)}$	TBiIN input cycle time (counted on both edges)	200		ns
$t_{w(TBH)}$	TBiIN input HIGH pulse width (counted on both edges)	80		ns
$t_{w(TBL)}$	TBiIN input LOW pulse width (counted on both edges)	80		ns

Table 1.26.16. Timer B input (pulse period measurement mode)

Symbol	Parameter	Standard		Unit
		Min.	Max.	
$t_{c(TB)}$	TBiIN input cycle time	400		ns
$t_{w(TBH)}$	TBiIN input HIGH pulse width	200		ns
$t_{w(TBL)}$	TBiIN input LOW pulse width	200		ns

Table 1.26.17. Timer B input (pulse width measurement mode)

Symbol	Parameter	Standard		Unit
		Min.	Max.	
$t_{c(TB)}$	TBiIN input cycle time	400		ns
$t_{w(TBH)}$	TBiIN input HIGH pulse width	200		ns
$t_{w(TBL)}$	TBiIN input LOW pulse width	200		ns

Table 1.26.18. A-D trigger input

Symbol	Parameter	Standard		Unit
		Min.	Max.	
$t_{c(AD)}$	ADTRG input cycle time (trigger able minimum)	1000		ns
$t_{w(ADL)}$	ADTRG input LOW pulse width	125		ns

Table 1.26.19. Serial I/O

Symbol	Parameter	Standard		Unit
		Min.	Max.	
$t_{c(CK)}$	CLKi input cycle time	300		ns
$t_{w(CKH)}$	CLKi input HIGH pulse width	150		ns
$t_{w(CKL)}$	CLKi input LOW pulse width	150		ns
$t_{d(C-Q)}$	TxDi output delay time		100	ns
$t_{h(C-Q)}$	TxDi hold time	0		ns
$t_{su(D-C)}$	RxDi input setup time	50		ns
$t_{h(C-D)}$	RxDi input hold time	90		ns

Table 1.26.20. External interrupt \overline{INTi} inputs

Symbol	Parameter	Standard		Unit
		Min.	Max.	
$t_{w(INH)}$	\overline{INTi} input HIGH pulse width	250		ns
$t_{w(INL)}$	\overline{INTi} input LOW pulse width	250		ns

Switching characteristics (referenced to V_{CC} = 3.3V, V_{SS} = 0V at Topr = - 20°C to 85°C / - 40°C to 85°C (Note 3), CM15 = "1" unless otherwise specified)

Table 1.26.21. Memory expansion and microprocessor modes (with no wait)

Symbol	Parameter	Measuring condition	Standard		Unit
			Min.	Max.	
t _d (BCLK-AD)	Address output delay time	Figure 1.26.1		50	ns
t _h (BCLK-AD)	Address output hold time (BCLK standard)		4		ns
t _h (RD-AD)	Address output hold time (RD standard)		0		ns
t _h (WR-AD)	Address output hold time (WR standard)		0		ns
t _d (BCLK-CS)	Chip select output delay time			50	ns
t _h (BCLK-CS)	Chip select output hold time (BCLK standard)		4		ns
t _d (BCLK-ALE)	ALE signal output delay time			40	ns
t _h (BCLK-ALE)	ALE signal output hold time		-4		ns
t _d (BCLK-RD)	RD signal output delay time			40	ns
t _h (BCLK-RD)	RD signal output hold time		0		ns
t _d (BCLK-WR)	WR signal output delay time			40	ns
t _h (BCLK-WR)	WR signal output hold time		0		ns
t _d (BCLK-DB)	Data output delay time (BCLK standard)			50	ns
t _h (BCLK-DB)	Data output hold time (BCLK standard)		4		ns
t _d (DB-WR)	Data output delay time (WR standard)		(Note1)		ns
t _h (WR-DB)	Data output hold time (WR standard)(Note2)		0		ns

Note 1: Calculated according to the BCLK frequency as follows:

$$t_d(\text{DB} - \text{WR}) = \frac{10^9}{f(\text{BCLK}) \times 2} - 50 \quad [\text{ns}]$$

Note 2: This is standard value shows the timing when the output is off, and doesn't show hold time of data bus. Hold time of data bus is different by capacitor volume and pull-up (pull-down) resistance value.

Hold time of data bus is expressed in

$$t = -CR \times \ln(1 - V_{OL} / V_{CC})$$

by a circuit of the right figure.

For example, when V_{OL} = 0.2V_{CC}, C = 30pF, R = 1kΩ, hold time of output "L" level is

$$t = -30\text{pF} \times 1\text{k}\Omega \times \ln(1 - 0.2V_{CC} / V_{CC}) = 6.7\text{ns}.$$

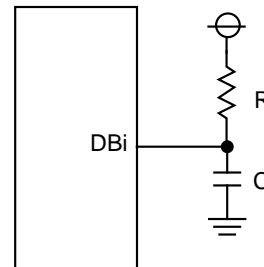

Note 3: Specify a product of -40°C to 85°C to use it.

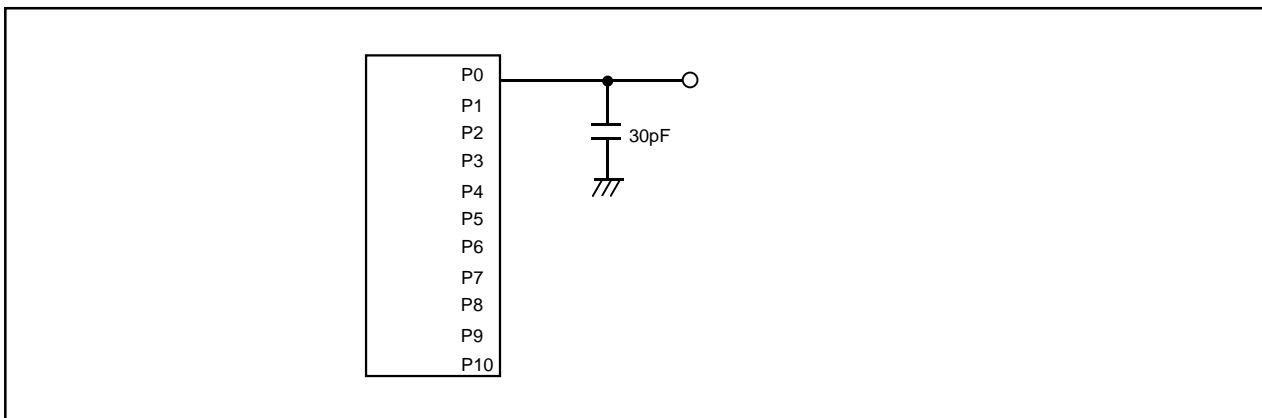

Figure 1.26.1. Port P0 to P10 measurement circuit

Switching characteristics (referenced to V_{CC} = 3.3V, V_{SS} = 0V at Topr = – 20°C to 85°C / – 40°C to 85°C (Note 3), CM15 = “1” unless otherwise specified)

**Table 1.26.22. Memory expansion and microprocessor modes
 (when accessing external memory area with wait)**

Symbol	Parameter	Measuring condition	Standard		Unit
			Min.	Max.	
t _d (BCLK-AD)	Address output delay time	Figure 1.26.1		50	ns
t _h (BCLK-AD)	Address output hold time (BCLK standard)		4		ns
t _h (RD-AD)	Address output hold time (RD standard)		0		ns
t _h (WR-AD)	Address output hold time (WR standard)		0		ns
t _d (BCLK-CS)	Chip select output delay time			50	ns
t _h (BCLK-CS)	Chip select output hold time (BCLK standard)		4		ns
t _d (BCLK-ALE)	ALE signal output delay time			40	ns
t _h (BCLK-ALE)	ALE signal output hold time		– 4		ns
t _d (BCLK-RD)	RD signal output delay time			40	ns
t _h (BCLK-RD)	RD signal output hold time		0		ns
t _d (BCLK-WR)	WR signal output delay time			40	ns
t _h (BCLK-WR)	WR signal output hold time		0		ns
t _d (BCLK-DB)	Data output delay time (BCLK standard)			50	ns
t _h (BCLK-DB)	Data output hold time (BCLK standard)		4		ns
t _d (DB-WR)	Data output delay time (WR standard)		(Note1)		ns
t _h (WR-DB)	Data output hold time (WR standard)(Note2)		0		ns

Note 1: Calculated according to the BCLK frequency as follows:

$$t_d(\text{DB} - \text{WR}) = \frac{10^9}{f(\text{BCLK})} - 50 \quad [\text{ns}]$$

Note 2: This is standard value shows the timing when the output is off, and doesn't show hold time of data bus. Hold time of data bus is different by capacitor volume and pull-up (pull-down) resistance value.

Hold time of data bus is expressed in

$$t = -CR \times \ln(1 - V_{OL} / V_{CC})$$

by a circuit of the right figure.

For example, when V_{OL} = 0.2V_{CC}, C = 30pF, R = 1kΩ, hold time of output “L” level is

$$t = -30\text{pF} \times 1\text{k}\Omega \times \ln(1 - 0.2V_{CC} / V_{CC}) = 6.7\text{ns}.$$

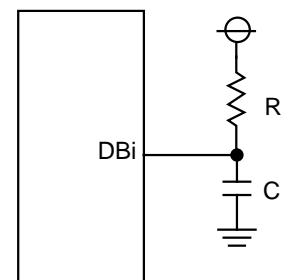

Note 3: Specify a product of -40°C to 85°C to use it.

Switching characteristics (referenced to $V_{CC} = 3.3V$, $V_{SS} = 0V$ at $T_{opr} = -20^{\circ}C$ to $85^{\circ}C$ / $-40^{\circ}C$ to $85^{\circ}C$ (Note 2), $CM15 = "1"$ unless otherwise specified)

Table 1.26.23. Memory expansion and microprocessor modes
(when accessing external memory area with wait, and select multiplexed bus)

Symbol	Parameter	Measuring condition	Standard		Unit
			Min.	Max.	
$t_{d(BCLK-AD)}$	Address output delay time	Figure 1.26.1		50	ns
$t_{h(BCLK-AD)}$	Address output hold time (BCLK standard)		4		ns
$t_{h(RD-AD)}$	Address output hold time (RD standard)		(Note1)		ns
$t_{h(WR-AD)}$	Address output hold time (WR standard)		(Note1)		ns
$t_{d(BCLK-CS)}$	Chip select output delay time			50	ns
$t_{h(BCLK-CS)}$	Chip select output hold time (BCLK standard)		4		ns
$t_{h(RD-CS)}$	Chip select output hold time (RD standard)		(Note1)		ns
$t_{h(WR-CS)}$	Chip select output hold time (WR standard)		(Note1)		ns
$t_{d(BCLK-RD)}$	RD signal output delay time			40	ns
$t_{h(BCLK-RD)}$	RD signal output hold time		0		ns
$t_{d(BCLK-WR)}$	WR signal output delay time			40	ns
$t_{h(BCLK-WR)}$	WR signal output hold time		0		ns
$t_{d(BCLK-DB)}$	Data output delay time (BCLK standard)			50	ns
$t_{h(BCLK-DB)}$	Data output hold time (BCLK standard)		4		ns
$t_{d(DB-WR)}$	Data output delay time (WR standard)		(Note1)		ns
$t_{h(WR-DB)}$	Data output hold time (WR standard)		(Note1)		ns
$t_{d(BCLK-ALE)}$	ALE signal output delay time (BCLK standard)			40	ns
$t_{h(BCLK-ALE)}$	ALE signal output hold time (BCLK standard)		-4		ns
$t_{d(AD-ALE)}$	ALE signal output delay time (Address standard)		(Note1)		ns
$t_{h(ALE-AD)}$	ALE signal output hold time (Address standard)		30		ns
$t_{d(AD-RD)}$	Post-address RD signal output delay time	0		ns	
$t_{d(AD-WR)}$	Post-address WR signal output delay time	0		ns	
$t_{dZ(RD-AD)}$	Address output floating start time		8	ns	

Note 1: Calculated according to the BCLK frequency as follows:

$$t_{h(RD-AD)} = \frac{10^9}{f(BCLK) \times 2} + 0 \quad [ns]$$

$$t_{h(WR-AD)} = \frac{10^9}{f(BCLK) \times 2} + 0 \quad [ns]$$

$$t_{h(RD-CS)} = \frac{10^9}{f(BCLK) \times 2} + 0 \quad [ns]$$

$$t_{h(WR-CS)} = \frac{10^9}{f(BCLK) \times 2} + 0 \quad [ns]$$

$$t_{d(DB-WR)} = \frac{10^9 \times 3}{f(BCLK) \times 2} - 50 \quad [ns]$$

$$t_{h(WR-DB)} = \frac{10^9}{f(BCLK) \times 2} + 0 \quad [ns]$$

$$t_{d(AD-ALE)} = \frac{10^9}{f(BCLK) \times 2} - 40 \quad [ns]$$

Note 2: Specify a product of $-40^{\circ}C$ to $85^{\circ}C$ to use it.

Timing

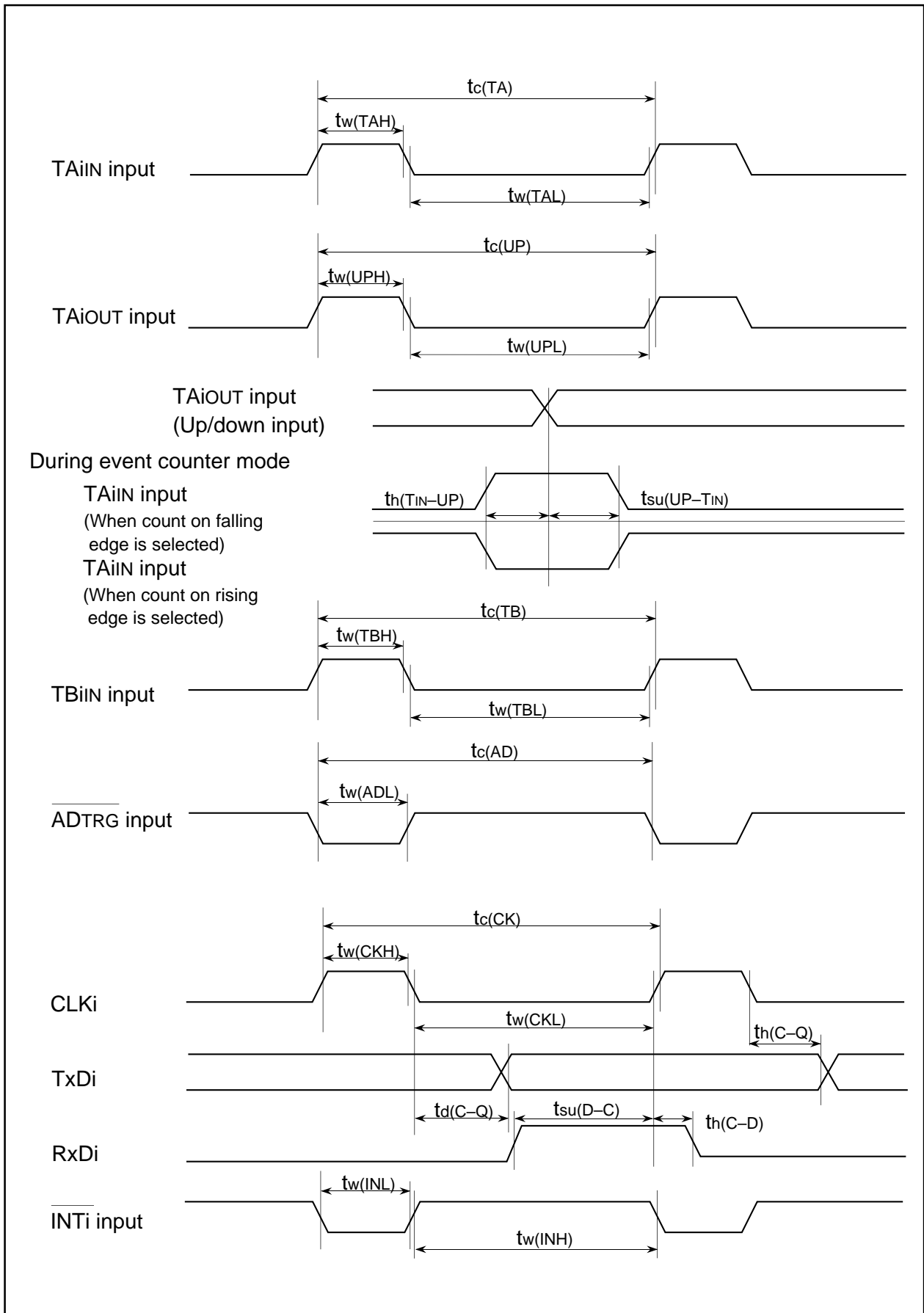
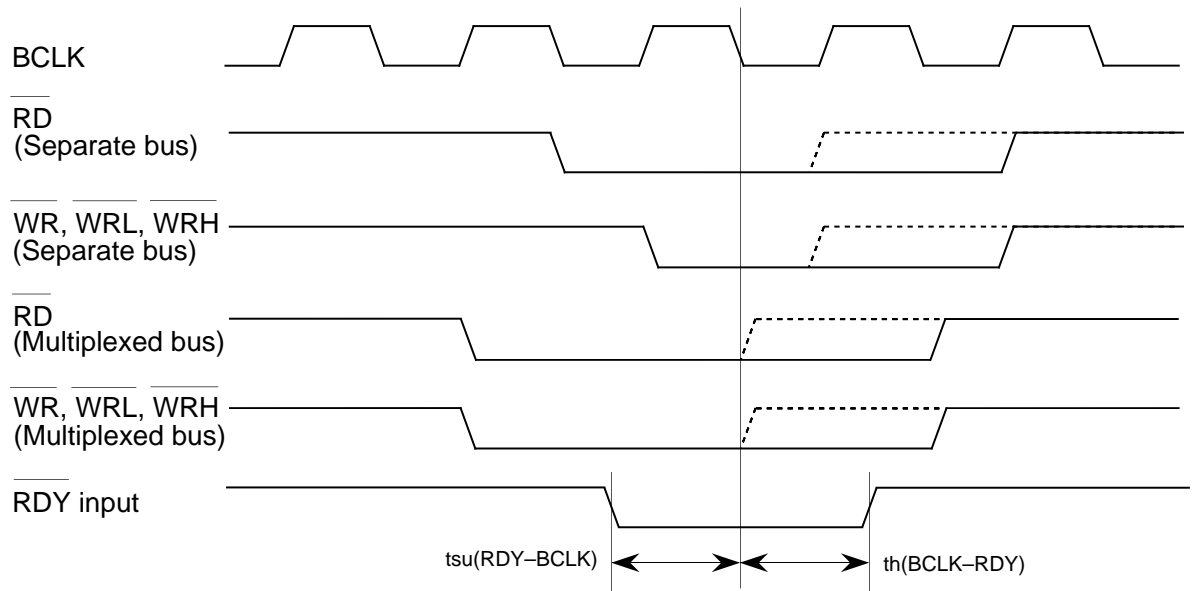

Figure 1.26.2. Timing diagram (1)

Memory Expansion Mode and Microprocessor Mode

(Valid only with wait)



(Valid with or without wait)

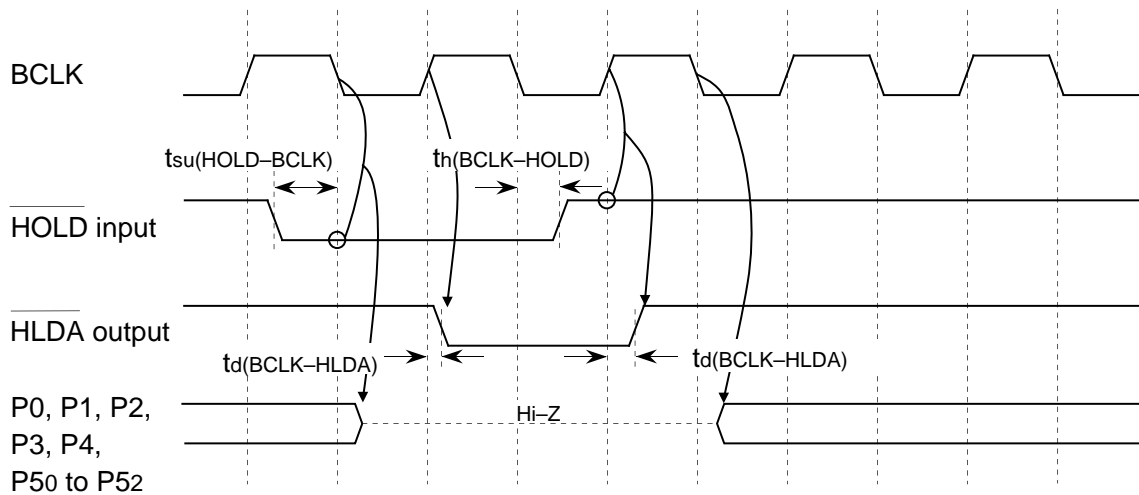

Note: The above pins are set to high-impedance regardless of the input level of the BYTE pin and bit (PM06) of processor mode register 0 selects the function of ports P40 to P43.

Measuring conditions :

- $V_{CC}=3.3V$
- Input timing voltage : Determined with $V_{IL}=0.66V$, $V_{IH}=2.64V$
- Output timing voltage : Determined with $V_{OL}=1.65V$, $V_{OH}=1.65V$

Figure 1.26.3. Timing diagram (2)

**Memory Expansion Mode and Microprocessor Mode
(With no wait)**

Read timing

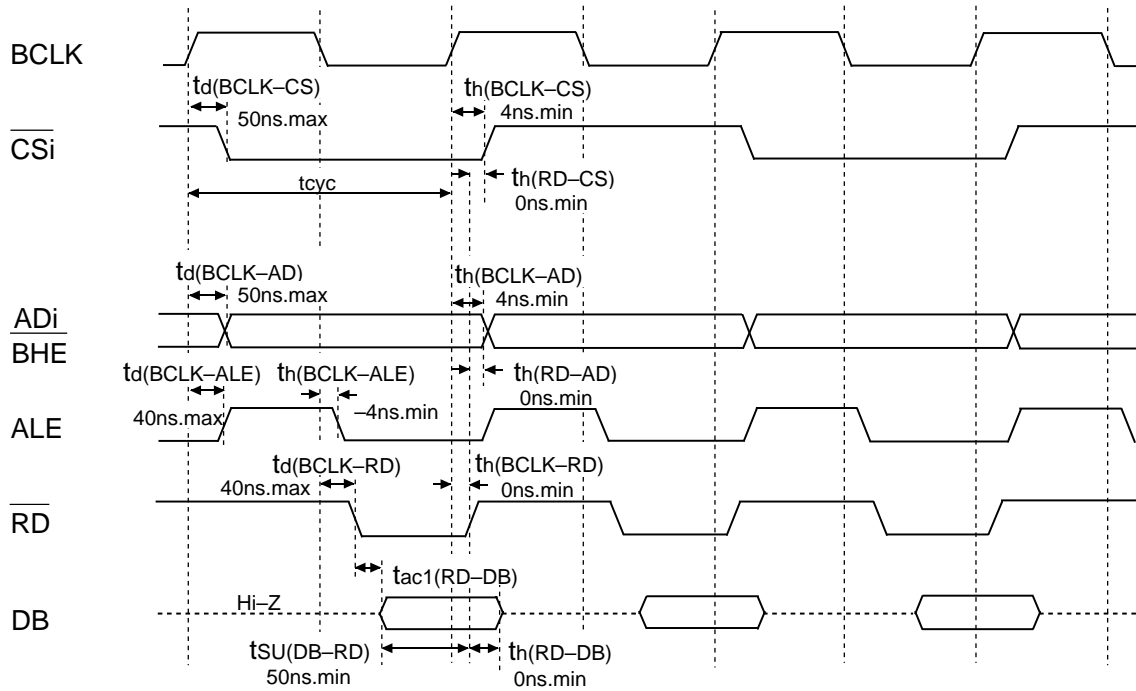

Write timing

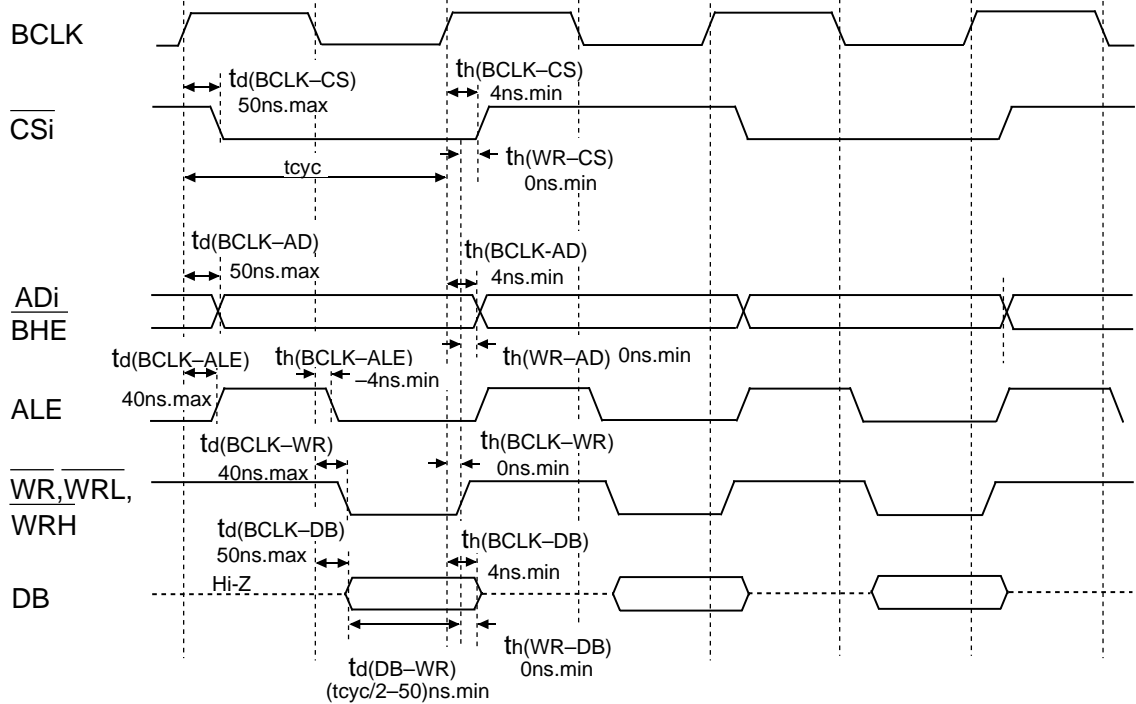
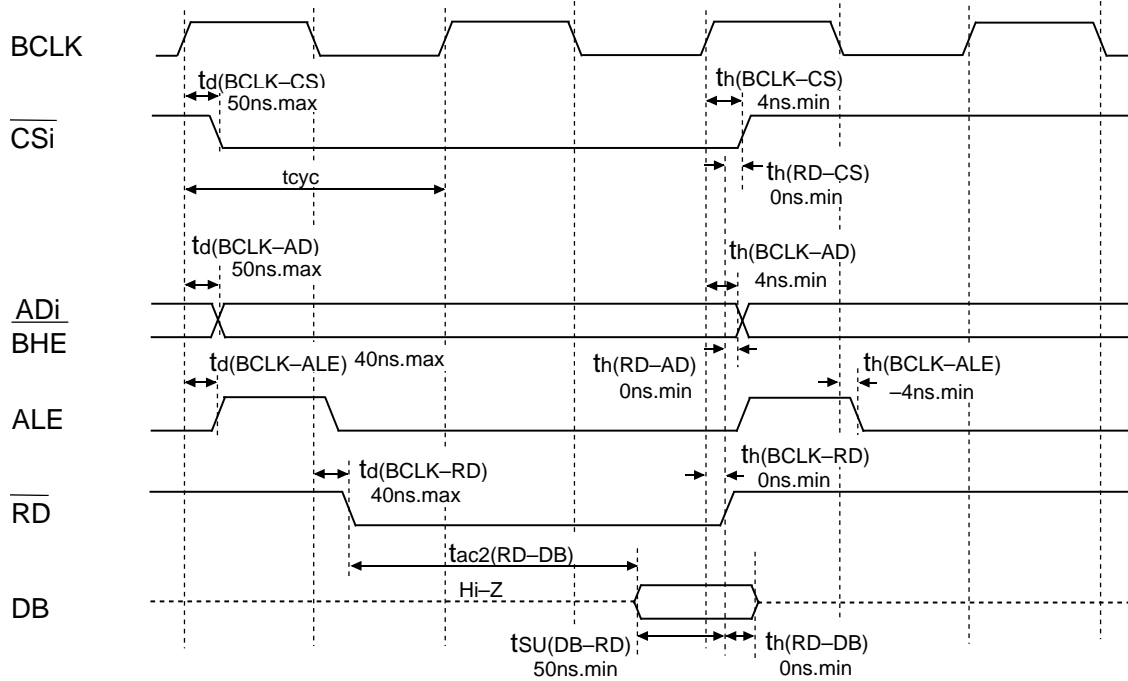

Figure 1.26.4. Timing diagram (3)

Memory Expansion Mode and Microprocessor Mode
(When accessing external memory area with wait)

Read timing



Write timing

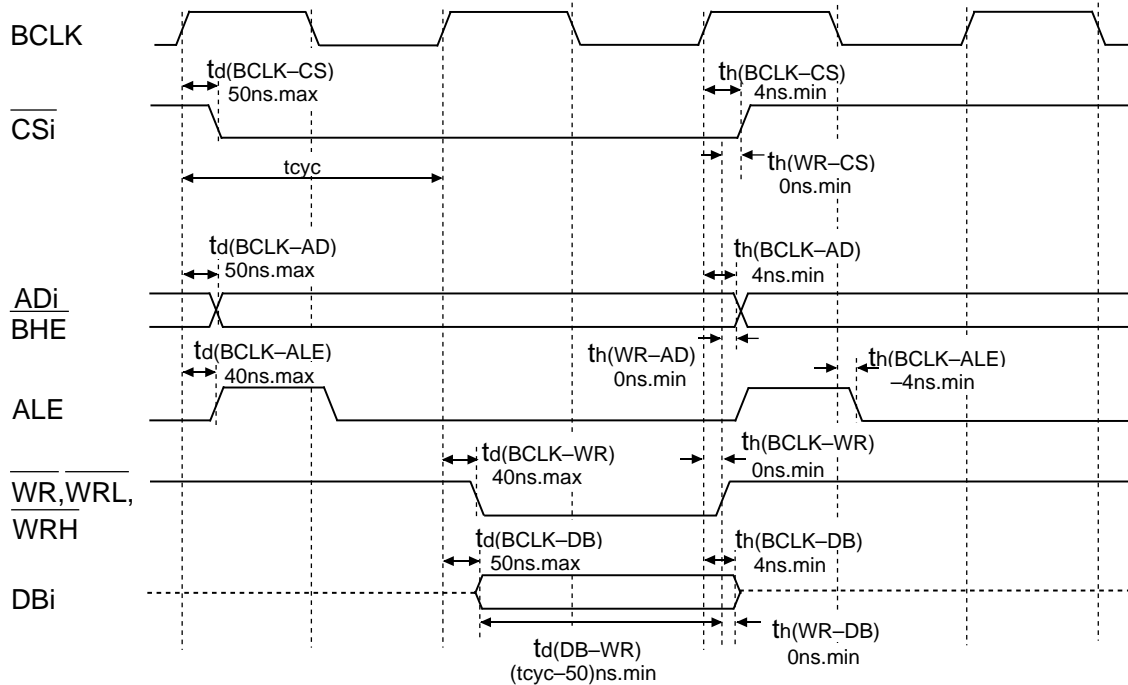

Measuring conditions :

- $V_{CC}=3.3V$
- Input timing voltage : Determined with: $V_{IL}=0.52V$, $V_{IH}=1.65V$
- Output timing voltage : Determined with: $V_{OL}=1.65V$, $V_{OH}=1.65V$

Figure 1.26.5. Timing diagram (4)

Package Outline

Package Outline

100P6S-A (MMP)

Plastic 100pin 14X20mm body QFP

EIAJ Package Code	JEDEC Code	Weight(g)	Lead Material
QFP100-P-1420-0.65	-	1.58	Alloy 42

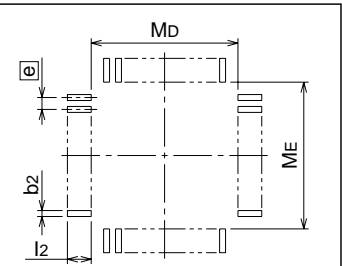
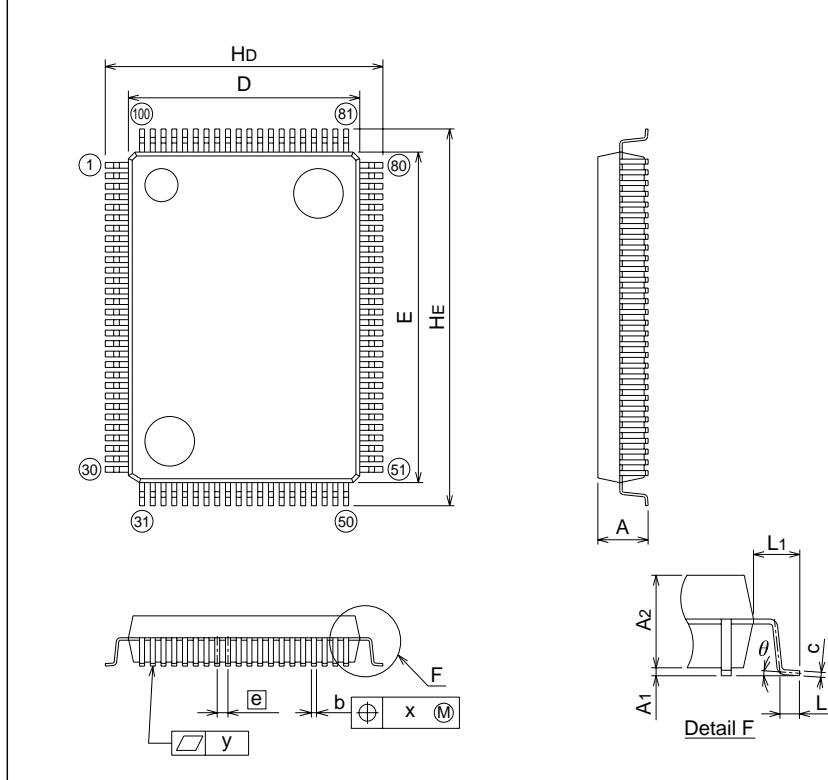

Recommended Mount Pad

Symbol	Dimension in Millimeters		
	Min	Nom	Max
A	-	-	3.05
A1	0	0.1	0.2
A2	-	2.8	-
b	0.25	0.3	0.4
c	0.13	0.15	0.2
D	13.8	14.0	14.2
E	19.8	20.0	20.2
e	-	0.65	-
Hd	16.5	16.8	17.1
HE	22.5	22.8	23.1
L	0.4	0.6	0.8
L1	-	1.4	-
x	-	-	0.13
y	-	-	0.1
θ	0°	-	10°
b2	-	0.35	-
l2	1.3	-	-
Md	-	14.6	-
ME	-	20.6	-

100P6Q-A (MMP)

Plastic 100pin 14X14mm body LQFP

EIAJ Package Code	JEDEC Code	Weight(g)	Lead Material
LQFP100-P-1414-0.50	-	0.63	Cu Alloy

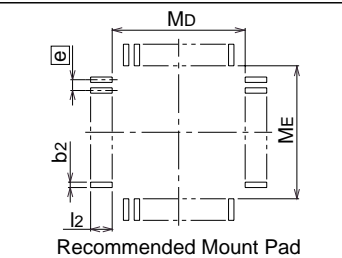
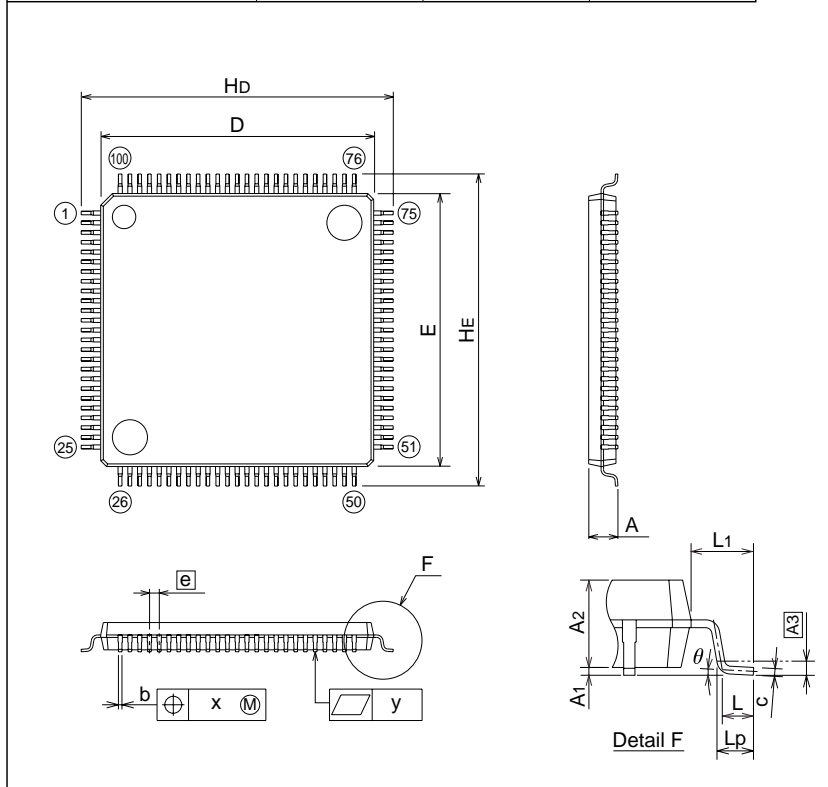

Recommended Mount Pad

Symbol	Dimension in Millimeters		
	Min	Nom	Max
A	-	-	1.7
A1	0	0.1	0.2
A2	-	1.4	-
b	0.13	0.18	0.28
c	0.105	0.125	0.175
D	13.9	14.0	14.1
E	13.9	14.0	14.1
e	-	0.5	-
Hd	15.8	16.0	16.2
HE	15.8	16.0	16.2
L	0.3	0.5	0.7
L1	-	1.0	-
Lp	0.45	0.6	0.75
A3	-	0.25	-
x	-	-	0.08
y	-	-	0.1
θ	0°	-	10°
b2	-	0.225	-
l2	0.9	-	-
Md	-	14.4	-
ME	-	14.4	-

SFR difference between M16C/62N and M16C/30L

Address	Symbol	M16C/62N	M16C/30L
0005	PM1	Processor mode register 1 bit0:Reserved bit bit1:Nothing is assigned bit2:Nothing is assigned PM13:Internal reserved area expansion bit PM14:Memory area expansion bit PM15: bit6:Reserved bit PM17:Wait bit	Processor mode register 1 bit0:Reserved bit bit1:Nothing is assigned bit2:Nothing is assigned bit3:Reserved bit bit4:Reserved bit bit5:Reserved bit bit6:Reserved bit PM17:Wait bit
000A	PRCR	Protect register PRC0:Enables writing to system clock control registers 0 and 1 PRC1:Enables writing to processor mode registers 0 and 1 PRC2:Enables writing to port P9 direction register and S/O control register bit3-bit7:Nothing is assigned	Protect register PRC0:Enables writing to system clock control registers 0 and 1 PRC1:Enables writing to processor mode registers 0 and 1 PRC2:Enables writing to port P9 direction register bit3-bit7:Nothing is assigned
000B	DBR	Data bank register	Reserved register
0030	SAR1	DMA1 source pointer	Reserved register
0031	SAR1	DMA1 source pointer	Reserved register
0032	SAR1	DMA1 source pointer	Reserved register
0034	DAR1	DMA1 destination pointer	Reserved register
0035	DAR1	DMA1 destination pointer	Reserved register
0036	DAR1	DMA1 destination pointer	Reserved register
0038	TCR1	DMA1 transfer counter	Reserved register
0039	TCR1	DMA1 transfer counter	Reserved register
003C	DM1CON	DMA1 control register	Reserved register
0044	INT3IC	INT3 interrupt control register	Reserved register
0045	TB5IC	Timer B5 interrupt control register	Reserved register
0046	TB4IC	Timer B4 interrupt control register	Reserved register
0047	TB3IC	Timer B3 interrupt control register	Reserved register
0048	S4IC/INT5IC	SI/O4,INT5 interrupt control register	Reserved register
0049	S3IC/INT4IC	SI/O3,INT4 interrupt control register	Reserved register
004C	DM1IC	DMA1 interrupt control register	Reserved register
0058	TA3IC	Timer A3 interrupt control register	Reserved register
0059	TA4IC	Timer A4 interrupt control register	Reserved register
005A	TB0IC	Timer B0 interrupt control register	Reserved register
0340	TBSR	Timer B3, 4, 5 count start flag	Reserved register
0342	TA11	Timer A1-1 register	Reserved register
0343	TA11	Timer A1-1 register	Reserved register
0344	TA21	Timer A2-1 register	Reserved register
0345	TA21	Timer A2-1 register	Reserved register
0346	TA41	Timer A4-1 register	Reserved register
0347	TA41	Timer A4-1 register	Reserved register
0348	INVC0	Three-phase PWM control register 0	Reserved register
0349	INVC1	Three-phase PWM control register 1	Reserved register
034A	IDB0	Three-phase output buffer register 0	Reserved register
034B	IDB1	Three-phase output buffer register 1	Reserved register
034C	DTT	Dead time timer	Reserved register
034D	ICTB2	Timer B2 interrupt occurrence frequency set counter	Reserved register
0350	TB3	Timer B3 register	Reserved register
0351	TB3	Timer B3 register	Reserved register
0352	TB4	Timer B4 register	Reserved register
0353	TB4	Timer B4 register	Reserved register
0354	TB5	Timer B5 register	Reserved register
0355	TB5	Timer B5 register	Reserved register
035B	TB3MR	Timer B3 mode register	Reserved register
035C	TB4MR	Timer B4 mode register	Reserved register
035D	TB5MR	Timer B5 mode register	Reserved register

Don't access a Reserved register.

SFR difference between M16C/62N and M16C/30L

SFR difference between M16C/62N and M16C/30L

Address	Symbol	M16C/62N	M16C/30L
035F	IFSR	Interrupt cause select register IFSR0:INT0 interrupt polarity switching bit IFSR1:INT1 interrupt polarity switching bit IFSR2:INT2 interrupt polarity switching bit IFSR3:INT3 interrupt polarity switching bit IFSR4:INT4 interrupt polarity switching bit IFSR5:INT5 interrupt polarity switching bit IFSR6:Interrupt request cause select bit IFSR7:Interrupt request cause select bit	Interrupt cause select register IFSR0:INT0 interrupt polarity switching bit IFSR1:INT1 interrupt polarity switching bit IFSR2:INT2 interrupt polarity switching bit bit3:Reserved bit bit4:Reserved bit bit5:Reserved bit bit6:Reserved bit bit7:Reserved bit
0360	S3TRR	SI/O3 transmit/receive register	Reserved register
0362	S3C	SI/O3 control register	Reserved register
0363	S3BRG	SI/O3 bit rate generator	Reserved register
0364	S4TRR	SI/O4 transmit/receive register	Reserved register
0366	S4C	SI/O4 control register	Reserved register
0367	S4BRG	SI/O4 bit rate generator	Reserved register
0380	TABSR	Count start flag TA0S:Timer A0 count start flag TA1S:Timer A1 count start flag TA2S:Timer A2 count start flag TA3S:Timer A3 count start flag TA4S:Timer A4 count start flag TB0S:Timer B0 count start flag TB1S:Timer B1 count start flag TB2S:Timer B2 count start flag	Count start flag TA0S:Timer A0 count start flag TA1S:Timer A1 count start flag TA2S:Timer A2 count start flag bit3:Reserved bit bit4:Reserved bit bit5:Reserved bit TB1S:Timer B1 count start flag TB2S:Timer B2 count start flag
0382	ONSF	One-shot start flag TA0OS:Timer A0 one-shot start flag TA1OS:Timer A1 one-shot start flag TA2OS:Timer A2 one-shot start flag TA3OS:Timer A3 one-shot start flag TA4OS:Timer A4 one-shot start flag bit5:Nothing is assigned TA0TGL:Timer A0 event/trigger select bit TA0TGH: "00", "01", "10" and "11" can be chosen.	One-shot start flag TA0OS:Timer A0 one-shot start flag TA1OS:Timer A1 one-shot start flag TA2OS:Timer A2 one-shot start flag bit3:Reserved bit bit4:Reserved bit bit5:Nothing is assigned TA0TGL:Timer A0 event/trigger select bit TA0TGH: "00", "01" and "11" can be chosen. "10" can't be chosen.
0383	TRGSR	Trigger select register TA1TGL:Timer A1 event/trigger select bit TA1TGH: "00", "01", "10" and "11" can be chosen. TA2TGL:Timer A2 event/trigger select bit TA2TGH: "00", "01", "10" and "11" can be chosen. TA3TGL:Timer A3 event/trigger select bit TA3TGH: "00", "01", "10" and "11" can be chosen. TA4TGL:Timer A4 event/trigger select bit TA4TGH: "00", "01", "10" and "11" can be chosen.	Trigger select register TA1TGL:Timer A1 event/trigger select bit TA1TGH: "00", "01", "10" and "11" can be chosen. TA2TGL:Timer A2 event/trigger select bit TA2TGH: "00", "01" and "10" can be chosen. "11" can't be chosen. bit4:Reserved bit bit5:Reserved bit bit6:Reserved bit bit7:Reserved bit
0384	UDF	Up-down flag TA0UD:Timer A0 up/down flag TA1UD:Timer A1 up/down flag TA2UD:Timer A2 up/down flag TA3UD:Timer A3 up/down flag TA4UD:Timer A4 up/down flag TA2P:Timer A2 two-phase pulse signal processing select bit TA3P:Timer A3 two-phase pulse signal processing select bit TA4P:Timer A4 two-phase pulse signal processing select bit	Up-down flag TA0UD:Timer A0 up/down flag TA1UD:Timer A1 up/down flag TA2UD:Timer A2 up/down flag bit3:Reserved bit bit4:Reserved bit TA2P:Timer A2 two-phase pulse signal processing select bit bit6:Reserved bit bit7:Reserved bit
038C	TA3	Timer A3	Reserved register
038D	TA3	Timer A3	Reserved register
038E	TA4	Timer A4	Reserved register
038F	TA4	Timer A4	Reserved register
0390	TB0	Timer B0	Reserved register
0391	TB0	Timer B0	Reserved register
0399	TA3MR	Timer A3 mode register	Reserved register
039A	TA4MR	Timer A4 mode register	Reserved register
039B	TB0MR	Timer B0 mode register	Reserved register

Don't access a Reserved register.

SFR difference between M16C/62N and M16C/30L

Address	Symbol	M16C/62N	M16C/30L
039C	TB1MR	Timer B1 mode register Event counter mode TMOD0:Operation mode select bit TMOD1: MR0:Count polarity select bit MR1: MR2:Nothing is assigned MR3:Invalid TCK1:Event clock select "0" and "1" can be chosen.	Timer B1 mode register Event counter mode TMOD0:Operation mode select bit TMOD1: MR0:Count polarity select bit MR1: MR2:Nothing is assigned MR3:Invalid TCK1:Event clock select "0" can be chosen. "1" can't be chosen.
03B4	FIDR	Flash identification register	Reserved register
03B7	FMR0	Flash memory control register 0	Reserved register
03B8	DM0SL	DMA0 request cause select register DMA0 request factors Falling edge of INT0 pin Software trigger Timer A0 Timer A1 Timer A2 Timer A3 Timer A4 two edges of INT0 pin Timer B0 Timer B1 Timer B2 Timer B3 Timer B4 Timer B5 UART0 transmit UART0 receive UART2 transmit UART2 receive UART1 transmit A-D conversion	DMA0 request cause select register DMA0 request factors Falling edge of INT0 pin Software trigger Timer A0 Timer A1 Timer A2 two edges of INT0 pin Timer B1 Timer B2 UART0 transmit UART0 receive UART2 transmit UART2 receive UART1 transmit A-D conversion
03BA	DM1SL	DMA1 request cause select register	Reserved register
03BC	CRCD	CRC data register	Reserved register
03BD	CRCIN	CRC data register	Reserved register
03BE	CRCIN	CRC input register	Reserved register
03D4	ADCON2	A-D control register 2 SMP:A-D conversion method select bit ADGSL0:Analog input group select bit ADGSL1: bit3:Reserved bit bit4-bit7:Nothing is assigned	A-D control register 2 SMP:A-D conversion method select bit bit1:Reserved bit bit2:Reserved bit bit3:Reserved bit bit4-bit7:Nothing is assigned
03D6	ADCON0	A-D control register 0 CH0:Analog input pin select bit CH1: CH2: MD0:A-D operation mode select bit 0 MD1: "00", "01", "10" and "11" can be chosen TRG:Trigger select bit ADST:A-D conversion start flag CKS0:Frequency select bit 0	A-D control register 0 CH0:Analog input pin select bit CH1: CH2: MD0:A-D operation mode select bit 0 MD1: "00" can be chosen. "01", "10" and "11" can't be chosen. TRG:Trigger select bit ADST:A-D conversion start flag CKS0:Frequency select bit 0
03D7	ADCON1	A-D control register 1 SCAN0:A-D sweep pin select bit SCAN1: MD2:A-D operation mode select bit 1 BITS:8/10-bit mode select bit CKS1:Frequency select bit 1 VCUT:Vref connect bit OPA0:External op-amp connection mode bit OPA1:	A-D control register 1 bit0:Reserved bit bit1:Reserved bit bit2:Reserved bit BITS:8/10-bit mode select bit CKS1:Frequency select bit 1 VCUT:Vref connect bit OPA0:External op-amp connection mode bit OPA1:
03D8	DA0	D-A register 0	Reserved register
03DA	DA1	D-A register 1	Reserved register
03DC	DACON	D-A control register	Reserved register

Don't access a Reserved register.



MITSUBISHI ELECTRIC CORPORATION

HEAD OFFICE: 2-2-3, MARUNOUCHI, CHIYODA-KU, TOKYO 100-8310, JAPAN

Keep safety first in your circuit designs!

- Mitsubishi Electric Corporation puts the maximum effort into making semiconductor products better and more reliable, but there is always the possibility that trouble may occur with them. Trouble with semiconductors may lead to personal injury, fire or property damage. Remember to give due consideration to safety when making your circuit designs, with appropriate measures such as (i) placement of substitutive, auxiliary circuits, (ii) use of non-flammable material or (iii) prevention against any malfunction or mishap.

Notes regarding these materials

- These materials are intended as a reference to assist our customers in the selection of the Mitsubishi semiconductor product best suited to the customer's application; they do not convey any license under any intellectual property rights, or any other rights, belonging to Mitsubishi Electric Corporation or a third party.
- Mitsubishi Electric Corporation assumes no responsibility for any damage, or infringement of any third-party's rights, originating in the use of any product data, diagrams, charts, programs, algorithms, or circuit application examples contained in these materials.
- All information contained in these materials, including product data, diagrams, charts, programs and algorithms represents information on products at the time of publication of these materials, and are subject to change by Mitsubishi Electric Corporation without notice due to product improvements or other reasons. It is therefore recommended that customers contact Mitsubishi Electric Corporation or an authorized Mitsubishi Semiconductor product distributor for the latest product information before purchasing a product listed herein.
The information described here may contain technical inaccuracies or typographical errors. Mitsubishi Electric Corporation assumes no responsibility for any damage, liability, or other loss rising from these inaccuracies or errors. Please also pay attention to information published by Mitsubishi Electric Corporation by various means, including the Mitsubishi Semiconductor home page (<http://www.mitsubishichips.com>).
- When using any or all of the information contained in these materials, including product data, diagrams, charts, programs, and algorithms, please be sure to evaluate all information as a total system before making a final decision on the applicability of the information and products. Mitsubishi Electric Corporation assumes no responsibility for any damage, liability or other loss resulting from the information contained herein.
- Mitsubishi Electric Corporation semiconductors are not designed or manufactured for use in a device or system that is used under circumstances in which human life is potentially at stake. Please contact Mitsubishi Electric Corporation or an authorized Mitsubishi Semiconductor product distributor when considering the use of a product contained herein for any specific purposes, such as apparatus or systems for transportation, vehicular, medical, aerospace, nuclear, or undersea repeater use.
- The prior written approval of Mitsubishi Electric Corporation is necessary to reprint or reproduce in whole or in part these materials.
- If these products or technologies are subject to the Japanese export control restrictions, they must be exported under a license from the Japanese government and cannot be imported into a country other than the approved destination.
Any diversion or reexport contrary to the export control laws and regulations of Japan and/or the country of destination is prohibited.
- Please contact Mitsubishi Electric Corporation or an authorized Mitsubishi Semiconductor product distributor for further details on these materials or the products contained therein.