

Features

- FAX and Modem interface (V29/V22 bis)
- Variants match German, UK & 600Ω network impedances
- Provides reinforced barrier to international PTT requirements
- Transformerless 2-4 Wire conversion
- Loop start operation
- Pulse and DTMF operation
- Accommodates external monitor phone
- Line state detection outputs:
- -loop current/ringing outputs
- Single +5V operation, low idle power (5mW)
- Full Duplex
- Suitable for power down applications

Applications

Interface to Central Office for:

- DAA
- Modem
- FAX
- Answering Machine
- Terminal Equipment

ISSUE 5

April 1995

Ordering Information

MH88422-1	14 Pin DIL Package
MH88422-2	14 Pin DIL Package
MH88422-3	14 Pin DIL Package

Surface Mount Options are available by adding the Suffix "S"

Description

The Mitel MH88422 Line Interface Circuit provides a complete audio and signalling link between audio equipment and central office. The functions provided by the MH88422 include 2-4 Wire conversion, loop seizure, ring voltage and loop current detection. The device is fabricated as thick film hybrid which incorporates various technologies for optimum circuit design, high voltage isolation and very high reliability.

Variants are provided to meet German (-1) and UK (-3) line impedance (see section on Line Impedances), as well as a 600Ω variants (-2).

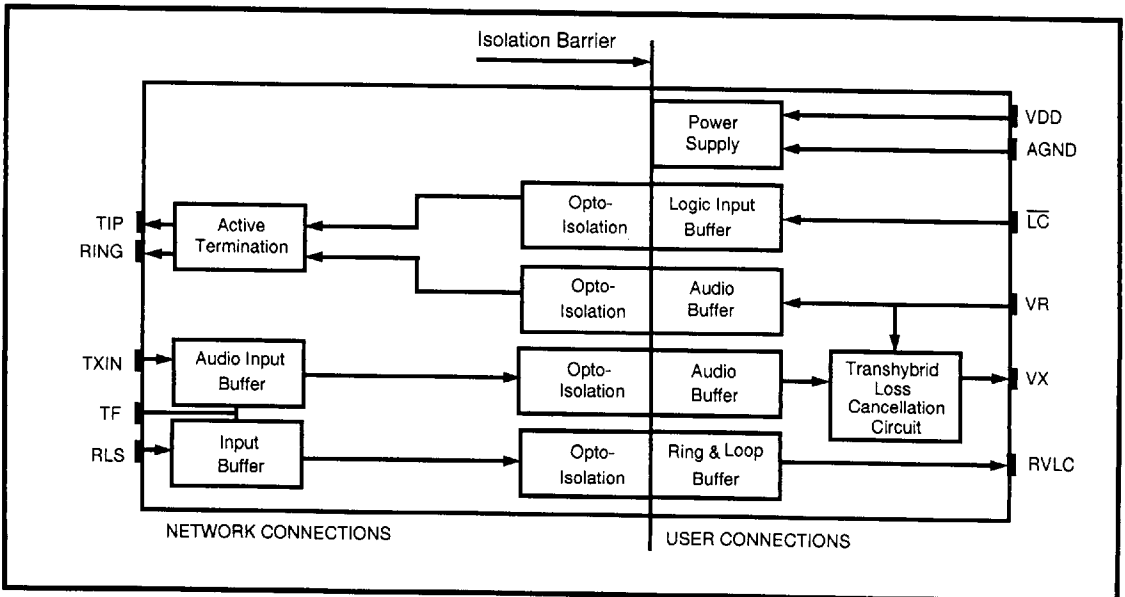

Figure 1 - Functional Block Diagram

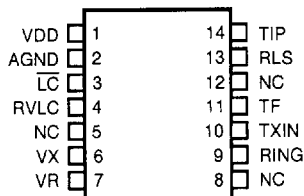

Figure 2 - Pin Connections

Pin Description

Pin #	Name	Description
1	VDD	Positive Power Supply Voltage. +5V.
2	AGND	Analog Ground. 4-Wire Ground. Normally connected to System Ground.
3	\overline{LC}	Loop Control (Input). A logic low activates internal circuitry which provides a dc termination across Tip and Ring. Used for seizing the line and dial pulsing.
4	RVLC	Ring Voltage and Current Detect (Output). A logic low indicates that loop current is detected. The loop current can be due to the external monitor phone or the MH88422 in the off-hook mode. The RVLC output pulses when the external monitor phone is dial pulsing or when the MH88422 is dial pulsing via the \overline{LC} input. In addition, when the MH88422 is on the on-hook mode, a pulsing output indicates ringing voltage across the Tip and Ring leads. The pulsing output frequency is twice the ringing frequency.
5	NC	No Connection should be made to this pin.
6	VX	Transmit (Output). 4-Wire ground (AGND) referenced audio output, biased at 2.5V. Outputs in off-hook mode only.
7	VR	Receive (Input). 4-Wire ground (AGND) referenced audio input, biased at 2.5V. \overline{LC} must be activated low and loop current must be flowing.
8	NC	No Connection should be made to this pin.
9	RING	Ring Lead. Connects to the "Ring" lead of the central office through an optional relay contact. The central office "Tip" and "Ring" leads may be interchanged.
10	TXIN	Transmit (Input). Connects to the "Ring" lead of the central office through a coupling capacitor.
11	TF	Tip Feed. Connects to the "Tip" lead of the central office through an internal resistor and an optional external resistor.
12	NC	No Connection should be made to this pin.
13	RLS	Ring Loop Sense (Input). Sense node for ringing voltage detector and the loop current detector.
14	TIP	Tip Lead. Connects to the "Tip" lead of the central office through an optional relay contact. The central office "Tip" and "Ring" leads may be interchanged.

Functional Description

The MH88422 Line Interface Circuit is a COIC (Central Office Interface Circuit) used to interface FAX's Modems or user defined equipment to Central Office 2-Wire Analog Trunks.

Opto-Isolation

The isolation barrier is designed to meet regulatory requirements for a reinforced barrier of 3kVac. It provides full isolation of mains voltages up to 250V RMS and all telecom voltages.

In order that this barrier is not bypassed a creepage/clearance distance of 6.4mm minimum must be maintained between wiring, pcb tracking, etc., connected to external circuitry on either side of the barrier. To make this requirement simpler, pins on the MH88422 connected to opposite sides of the barrier are on opposite sides of the package.

External Protection Circuit

To meet regulatory high voltage requirement, an external protection circuit is required. The protection circuit shown in Figure 3 (Clamp Diode D1) is recommended.

DC Loop Termination

The DC loop termination circuitry provides the loop with an active DC load termination when a logic low is applied to the \overline{LC} (Loop Control) input. The termination is similar to a resistance of approximately 300 Ω (loop current dependent). Internal optically isolated circuitry is used to switch the termination in and out the loop. This is used for both seizing the line as well as generating dial pulses. The MH88422 will not seize the line when powered down.

Supervision Features

The supervision circuitry is capable of detecting ringing voltage and loop current as well as the status of an optional external monitor phone. The RVLC (Ring Voltage Loop Current Detect) output provides a logic low when loop current flows due to the external monitor phone or the MH88422 being in the off-hook mode.

The RVLC outputs pulses when the external monitor phone is dial pulsing or when the MH88422 is dial pulsing via the \overline{LC} mode.

In addition, when the MH88422 is on-hook, a pulsing output indicates that ringing voltage is across the tip and ring leads; the pulsing output frequency is twice the ringing frequency. See Figure 3.

Ringing frequency may require external validation. An RC monostable is usually satisfactory for this purpose or this may also be achieved using software applications.

2-4 Wire Conversion

The 2-4 Wire conversion circuit converts the balanced full duplex signal at Tip and Ring of the central office line into a transmit ground referenced signal at VX (Transmit) of the MH88422. It also converts the receive ground referenced signal at VR (Receive) of the MH88422 into a balanced transmit signal at Tip and Ring of the central office line.

In full duplex transmission, the Tip-Ring signal consists of an audio signal from the central office as well as an audio signal due to the VR input. There is an internal cancellation circuit which prevents the VR signal appearing at the VX output. The degree to which the 2-4 wire conversion circuit minimizes the contribution of the VR signal at the VX output is specified as transhybrid loss (THL).

The MH88422 is suitable to drive a COMBO II codec or a VLSI modem device.

Line Impedance

The MH88422 provides a fixed Tip-ring impedance which conforms to the following PTT requirements.

MH88422-1 $Z_{in} = 200 + 820 // 115nF$
Germany

MH88422-2 $Z_{in} = 600\Omega$

MH88422-3 $Z_{in} = 370 + 620 // 310nF$
UK

Absolute Maximum Ratings* - All voltages are with respect to AGND unless otherwise specified.

	Parameter	Symbol	Min	Max	Units
1	DC Supply Voltage	V_{DD}	-0.3	6	V
2	Storage Temperature	T_S	-55	+80	°C
3	DC Loop Voltage	V_{Bat}	-100	+100	V
4	Ringing Voltage	V_R	-	120	V_{RMS}
5	Loop Current	I_{Loop}	-	90	mA

* Exceeding these values may cause permanent damage. Functional operation under these conditions is not implied

Recommended Operating Conditions.

	Parameters	Sym	Min	Typ [‡]	Max	Units	Test Conditions
1	DC Supply Voltages	V_{DD}	4.5	5.0	5.5	V	
2	Operating Temperature	T_{OP}	0		70	°C	
3	Ringing Voltage	V_R		75		V_{RMS}	$V_{Bat}=-48V$

‡ Typical figures are at 25°C with nominal +5V supply and are for design aid only

Loop Electrical Characteristics*

	Characteristics	Sym	Min	Typ [‡]	Max	Units	Test Conditions
1	Ringing Voltage -1 Variant only	VR			20	V_{RMS}	Refer to FT2 1TR2 for test method
	No Detect Detect		27		V_{RMS}		
	Ringing Voltage All other Variants	VR			7	V_{RMS}	Externally Adjustable
	No Detect Detect		14		V_{RMS}		
2	Ringing Frequency		15		68	Hz	
3	On-Hook 2-wire Impedance			40k		Ω	1kHz
4	Operating Loop Current		15		80	mA	
5	Operating Loop Resistance				2800	Ω	$V_{Bat}=-48V, I_{Loop}=15mA$
6	Off-Hook DC Voltage	-1 Variant	6.0		9.6	V	$I_{Loop}=25mA$ $I_{Loop}=42mA$ $I_{Loop}=15-20mA$ $I_{Loop}=26mA$ $I_{Loop}=25mA$ $I_{Loop}=42mA$
			6.0		15	V	
			4.0		6.0	V	
			4.0		7.8	V	
			6.0		9.0	V	
	-2 Variant	6.0		12.5	V		
		6.0			V		
	-3 Variant	6.0			V		
		6.0			V		
7	Leakage Current (2-Wire to AGND)				10	μA	100V _{DC}
8	Leakage Current on Hook (Tip to Ring)			9	10	μA	$V_{Bat}=-50V$
9	DC Resistance during dialling -1 variant only			200	220	Ω	$I_{Loop}=20-40mA$
10	Dial Pulse Distortion	ON	0	+2	+4	ms	
	-1 Variant	OFF	+6	+8	+10	ms	
	All other Variant		0	+2	+4	ms	

* Loop Electrical Characteristics are over recommended operating conditions unless otherwise stated.

‡ Typical figures are at 25°C and are for design aid only.

Note 1: All of the above characteristics use a test circuit as per Figure 3.

DC Electrical Characteristics†

	Characteristics	Sym	Min	Typ‡	Max	Units	Test Conditions
1	Supply Current	I _{DD}		3		mA	V _{DD} = -5.0V, Idle state
2	Power Consumption	PC		15		mW	V _{DD} = -5.0V, Idle state
3	Low Level Output Voltage	V _{OL}			0.4	V	I _{OL} = 4mA
	High Level Output Voltage	V _{OH}	2.4			V	I _{OH} = 0.4mA
4	Low Level Input Voltage	V _{IL}			0.8	V	
	High Level Input Voltage	V _{IH}	2.0			V	
	Low Level Input Current	I _{IH}			60	µA	V _{IH} = 5.0V
	High Level Input Current	I _{IL}			60	µA	V _{IL} = 0.0V

† DC Electrical Characteristics are over Recommended Operating Conditions unless otherwise stated.

‡ Typical figures are at 25°C with nominal ± 5V supplies and are for design aid only.

AC Electrical Characteristics† - MH88422 All Variants

	Characteristics	Sym	Min	Typ‡	Max	Units	Test Conditions
1	Input Impedance VR			47k		Ω	
2	Output Impedance at VX			10		Ω	
3	Receive Gain (VR to 2-wire)			3.5		dB	Input 0.5V at 1kHz
4	Frequency Response Gain (relative to Gain @ 1kHz)			0		dB	300 Hz
				0		dB	3400 Hz
5	Signal Output Overload Level						THD ≤5% @ 1kHz I _{Loop} = 15 to 40mA
	at 2-Wire		+2.0	+3.0		dBm	V _{DD} =4.5V to 5.5V
	at VX		+2.0	+3.0		dBm	
6	Total Harmonic Distortion	THD		1.2		%	Input -10dB at 1kHz DC loop = 25mA V _{DD} =5.0V
	at 2-wire			1.2		%	
	at VX						
7	Power Supply Reject Ratio	PSRR		30		dB	Ripple 0.1V, 1kHz on V _{DD}
	at 2-wire			30		dB	
	at VX						
8	Transhybrid Loss	THL		20		dB	Input -3.5dBm, 1kHz at V _R

† Electrical Characteristics are over Recommended Operating Conditions unless otherwise stated.

‡ Typical figures are at 25°C and are for design aid only.

Note 1: All of the above characteristics use a test circuit as per Figure 3.

Note 2: All of the above test conditions use a test source impedance which matches the device's impedance.

Note 3: dBm is referenced to 600Ω unless otherwise stated.

AC Electrical Characteristics[†] - MH88422-1

	Characteristics	Sym	Min	Typ [‡]	Max	Units	Test Conditions
1	2-Wire input Impedance (200Ω + 820Ω //115nF)	Zin		900		Ω	@ 1kHz
2	Return Loss at 2-Wire (200Ω + 820Ω //115nF)	RL	20	22		dB	300-500Hz
			20	24		dB	500-2500Hz
			20	26		dB	2500-3400Hz
3	Longitudinal to Metallic Balance		40	65		dB	50-300Hz
			55	60		dB	300-1000Hz
			53	60		dB	1000-4000Hz
4	Idle Channel Noise at 2-Wire At VX	Nc		-72 -72	-58	dBmp dBmp	
5	Transmit Gain (2-Wire to VX)			-0.4		dB	Input 0.5V @ 1kHz Off-Hook
6	Frequency Response Gain (relative to gain @ 1kHz)			-0.6		dB	300Hz
				-0.6		dB	3400Hz

[†] Electrical Characteristics are over Recommended Operating Conditions unless otherwise stated.

[‡] Typical figures are at 25°C and are for design aid only.

AC Electrical Characteristics[†] - MH88422-2

	Characteristics	Sym	Min	Typ [‡]	Max	Units	Test Conditions
1	2-Wire Input Impedance (600Ω)	ZIn		600		Ω	@ 1kHz
2	Return Loss at 2-Wire (Reference 600Ω)	ERL SFRL	20	20		dB	500-2500Hz
			14	18		dB	200-3200Hz
3	Longitudinal to Metallic Balance Metallic to Longitudinal Balance		58	60		dB	200-1000Hz
			53	55		dB	1k-3kHz
			60			dB	200-1000Hz
			40			dB	1k-4kHz
4	Idle Channel Noise at 2-Wire at VX	Nc		13 13	20	dBmC dBmC	
5	Transmit Gain (2-Wire to Vx)			-0.4		dB	Input 0.5V @ 1kHz Off-Hook
6	Frequency Response Gain (relative to gain @ 1kHz)			-0.6		dB	200Hz
				-0.6		dB	3400Hz

[†] Electrical Characteristics are over Recommended Operating Conditions unless otherwise stated.

[‡] Typical figures are at 25°C and are for design aid only.

AC Electrical Characteristics[†] - MH88422-3

	Characteristics	Sym	Min	Typ [‡]	Max	Units	Test Conditions
1	2-Wire Input Impedance (370Ω + 620Ω // 310nF)	Zin		700		Ω	@ 1kHz
2	Return Loss at 2-Wire (370Ω + 620Ω // 310nF)	RL	18	20		dB	200-2400Hz
3	Longitudinal to Metallic Balance		50	60		dB	300-3400Hz
4	Idle Channel Noise at 2-Wire at VX	Nc		-80 -80	-70 -68	dBmp dBmp	
5	Transmit Gain (2-Wire to Vx)			-0.4		dB	Input 0.5V @ 1kHz Off-Hook
6	Frequency Gain (relative to gain @ 1kHz)			-0.6 -0.6		dB dB	300Hz 3400Hz

[†] AC Electrical Characteristics are over Recommended Operating Conditions unless otherwise stated.

[‡] Typical figures are at 25°C and are for design aid only.

Note 1: All of the above characteristics use a test circuit as per Figure 3.

Note 2: All of the above test conditions use a test source impedance which matches the device's impedance.

Note 3: dBm is referenced to 600Ω unless otherwise stated.

TIP-RING Drive Circuit

The audio input ground (AGND) referenced signal at VR, biased at 2.5V, is converted to a balanced output signal at Tip-Ring. 2-4 wire isolation is achieved through the use of optocouplers when the LC input is activated, low, and loop current flowing.

TIP-RING Receive Circuit

The differential audio signal at Tip-Ring is converted to a ground (AGND) referenced signal, biased at 2.5V, at the VX output. 2-4 Wire isolation is achieved through the use of optocouplers. The receive circuit operated when LC is low and loop current is flowing

Transmit Gain

Transmit Gain (Tip-Ring to VX) is fixed as indicated in "AC Electrical Characteristics".

However, by adding external resistors to the VX output, the Transmit Gain can be reduced as shown in Figure 5. To limit the output current drawn, the minimum recommended resistance to ground is 2kΩ.

Overall Transmit Gain =

$$-0.4 \text{ dB} + 20\log (R4 / (R4 + R3))$$

The output impedance of the VX output is about 10Ω, therefore, with two external 1kΩ resistors configured as per Figure 5, this will result in 6dB of attenuation for a total gain of -6.4dB. For correct gain, the MH88422 input impedance must match the line impedance.

Receive Gain

Receive Gain (VR to Tip-Ring) is fixed as indicated in "AC Electrical Characteristics". However, by adding a single external resistor in series with the VR input, the Receive Gain can be reduced.

Overall Receive Gain =

$$3.5\text{dB} + 20\log (47\text{k}\Omega / (47\text{k}\Omega + R_{\text{ext}})),$$

The input impedance of the VR input is 47kΩ, therefore, an external 100kΩ resistor in series with this input will result in 10dB of attenuation for a total gain of -6.5dB.

For correct gain, the MH88422 input impedance must match the line impedance.

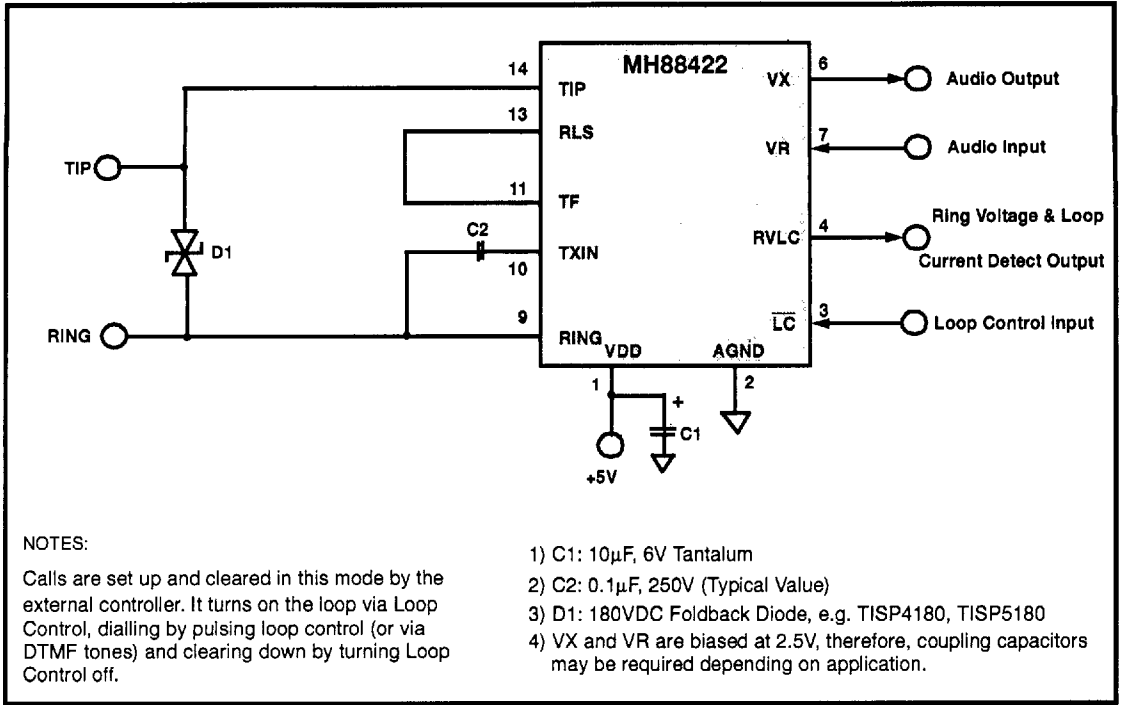

Figure 3 - Typical Application Circuit

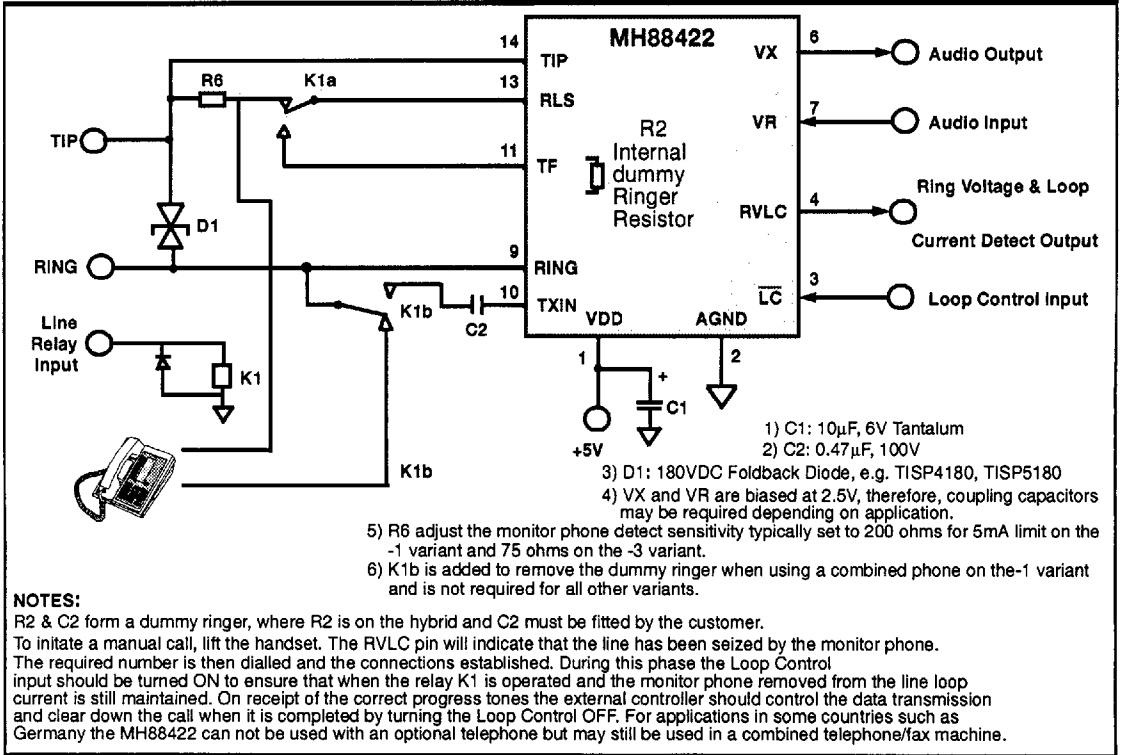

Figure 4 - Typical Application Circuit with Dummy Ringer and Monitor Phone

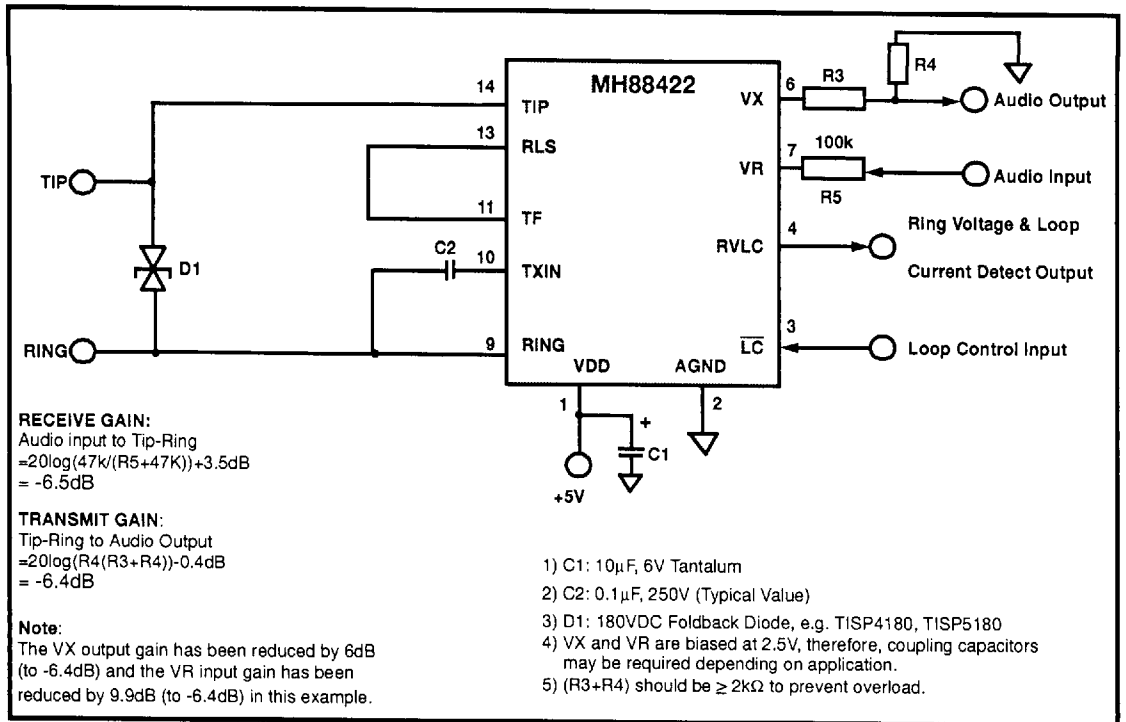

Figure 5 - Typical Application Circuit for Gain Adjustment

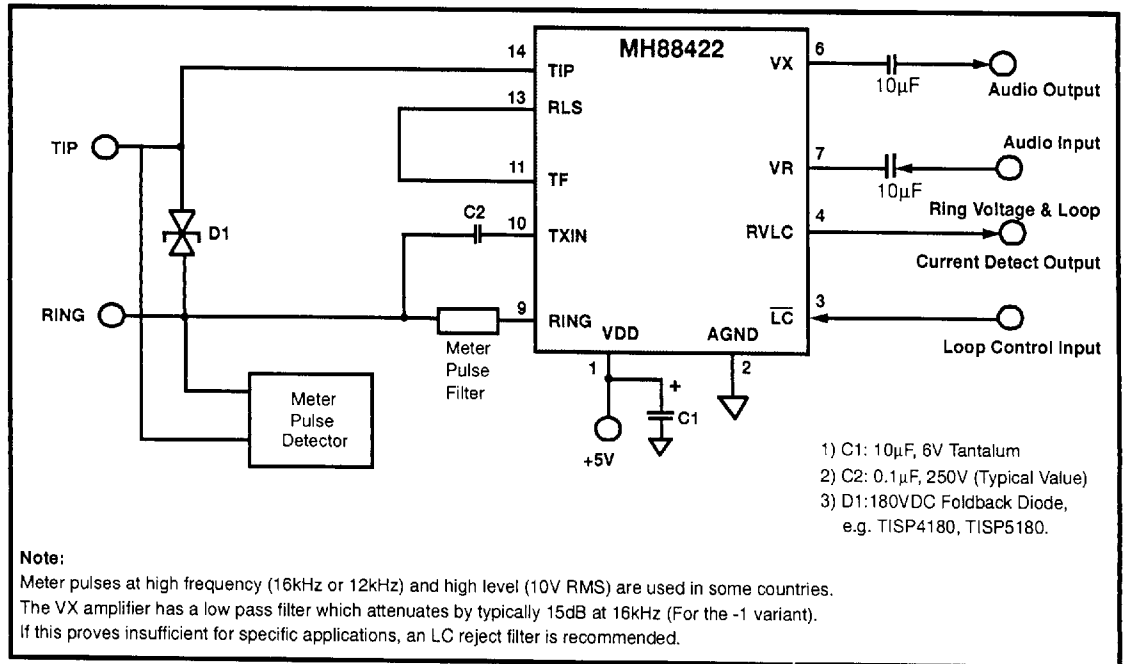

Figure 6 - Typical Application Circuit with Meter Pulse Filter and Coupling Capacitor

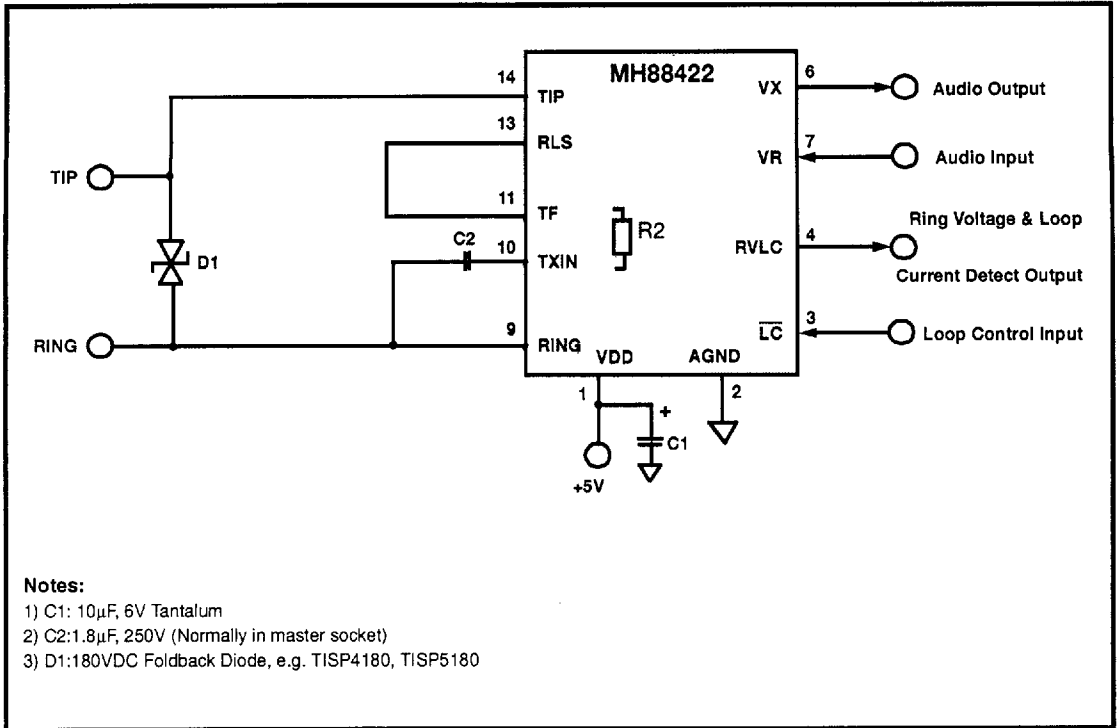

Figure 7 -Typical Application Circuit showing UK Dummy Ringer Circuit.

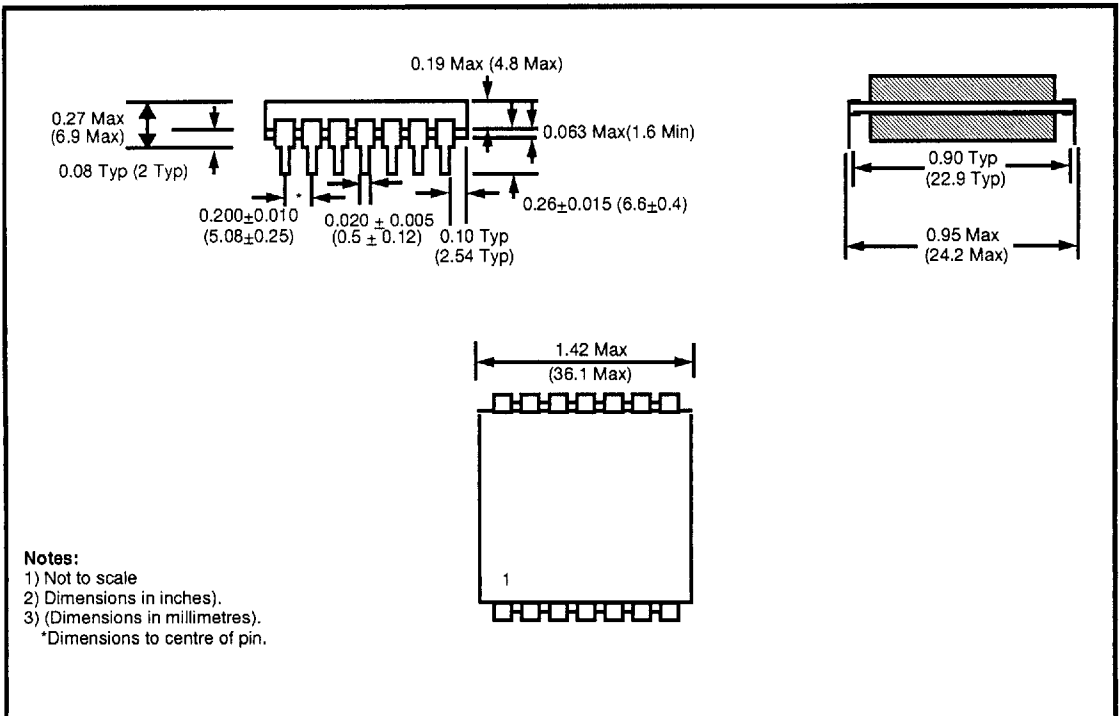

Figure 8 - Mechanical Data for 14 Pin DIL Hybrid

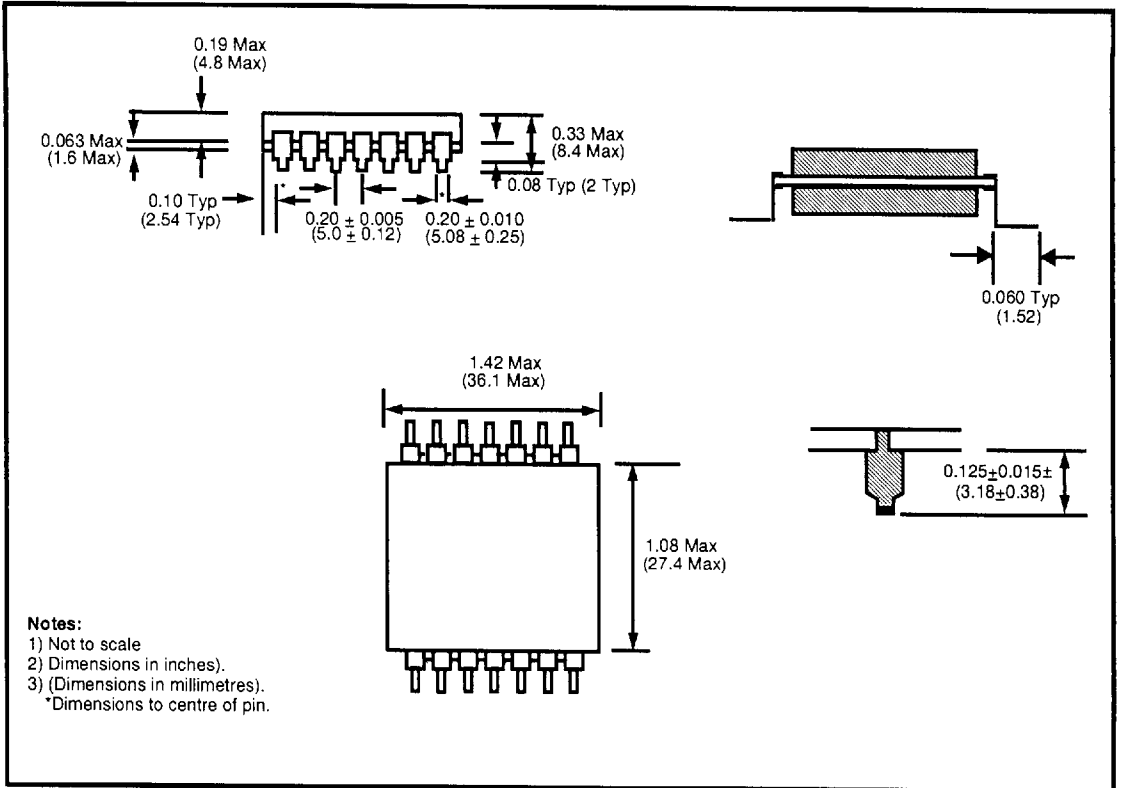

Figure 9 - Mechanical Data for 14 Pin Surface Mount Hybrid

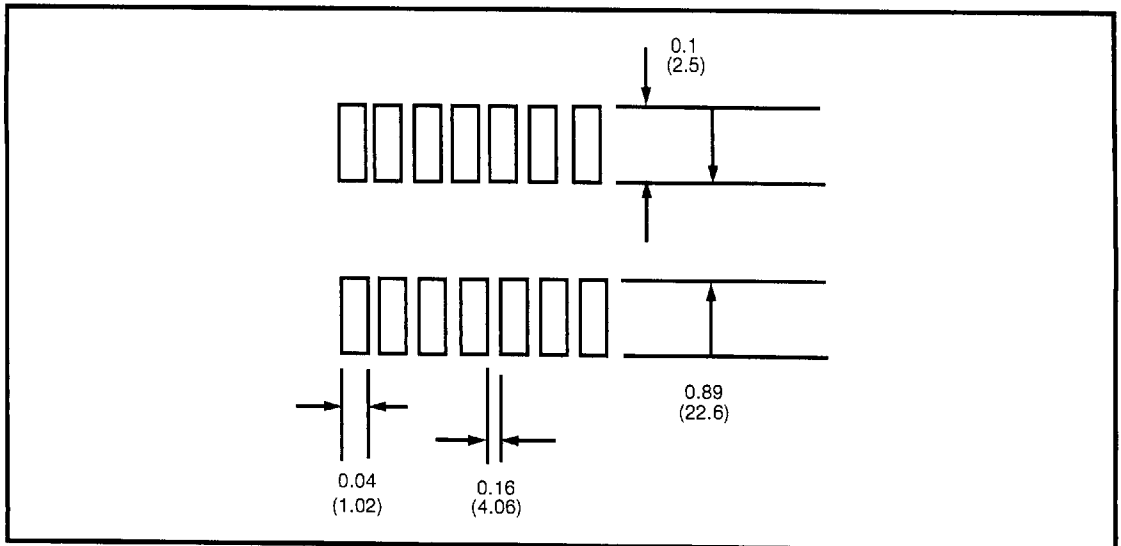

Figure 10 - Recommended Footprint for 14 Pin Surface Mount Hybrid