



ML2308

Stereo Recording/Playback LSI with Built-in Buffer Memory

INTRODUCTION

Both a serial interface and a parallel interface are available with the ML2308 through the use of a pin switch. Refer to pages 3 to 16 for information on the serial interface, and pages 17 to 24 for information on the parallel interface.

Also, common information such as command functions, operation flow and examples of applied circuits are described on page 25 and subsequent pages.

GENERAL DESCRIPTION

The ML2308 is a stereo recording/playback LSI that has integrated in a single chip all the functions required for recording and playing back audio data.

Analog signals fed into the microphone or line inputs are converted into digital signals by the analog to digital converter, and output to external equipment via the buffer memory. Further, digital signals from external equipment are converted into PWM signals by the 1-bit digital to analog converter, and output by the PWM driver that can directly drive the headphones. The influence of noise is lower with the ML2308 when compared with the mixed analog LSI, since most of the signals are digitally processed inside the LSI.

FEATURES

User Interfaces

- Supports Serial Peripheral Interface (SPI) or 8-bit bus interface
- Buffer memory for audio data buffer: 128 bytes (64 bytes each for left and right channels)
- Buffer memory status output pins FUL, MID, EMP

Codec section/audio input and output sections

- Audio synthesis method:
μ-law G.711 compliant 8-bit PCM, 8-bit/16-bit linear PCM, 8-bit Oki non-linear PCM, 2-bit/3-bit/4-bit/5-bit/6-bit/7-bit/8-bit ADPCM2
- Sampling frequency: 4.0 kHz to 32 kHz (selectable with commands)
- Built-in stereo Δ - Σ type 1-bit A/D converter S/(N+D): 80 dB DR, S/N: 85 dB
- Built-in stereo Δ - Σ type 1-bit D/A converter S/(N+D): 75 dB DR, S/N: 85 dB
- Built-in PWM driver for driving a speaker (150mW max, RL = 16 Ω , at BTL)
- Microphone amplifier \times 2, Line amplifier \times 2 (Stereo)
- Dynamic Range Control (DRC) automatic recording level adjustment function
- Recording input level detect function

Control commands

- Volume control : 256 steps, 0 dB to -48.16 dB, OFF
- PAN control : 16 steps, 0 dB to -24.08 dB, OFF

- Power supply voltage : +2.7 V to +3.6 V
- Operating temperature : -20°C to +70°C
- Source oscillation frequency : 24.576MHz
- Package : 48-pin plastic QFN (P-VQFN48-0707-0.50) (ML2308GD)

TABLE OF CONTENTS

introduction	1
General Description	1
Features	1
(1) SERIAL INTERFACE	3
BLOCK DIAGRAM	3
PIN CONFIGURATION (TOP VIEW)	4
DESCRIPTION OF PINS	5
WHEN PLACING AN ORDER	8
ABSOLUTE MAXIMUM RATINGS	9
RECOMMENDED OPERATING CONDITIONS	9
ELECTRICAL CHARACTERISTICS	9
DC Characteristics	9
Analog Section Characteristics	10
DESCRIPTION OF FUNCTIONS	11
Command Interface	11
1. SPI mode	11
2. Command Data Write Timing	13
3. Status Read Timing	13
Audio Interface	14
1. At I ² S Formatting	14
2. At Front-Aligned MSB First Formatting	15
3. Data Configurations for Respective Audio Synthesis Methods	16
(2) Parallel Interface	18
BLOCK DIAGRAM	18
PIN CONFIGURATION (TOP VIEW)	19
DESCRIPTION OF PINS	20
WHEN PLACING AN ORDER	23
ABSOLUTE MAXIMUM RATINGS	24
RECOMMENDED OPERATING CONDITIONS	24
ELECTRICAL CHARACTERISTICS	24
DC Characteristics	24
Analog Section Characteristics	25
(3) Common to Serial and parallel interfaces	26
DESCRIPTION OF FUNCTIONS	26
Relationship between Source oscillation frequency and Sampling Frequency	26
Audio Synthesis Methods	26
Restriction of Sampling Frequency	26
Buffer Memory Configuration	27
Command Functions	28
Command List	28
Power Supply Wiring	29
EXAMPLE Of APPLICATION CIRCUIT (Paralel interface, single-end output)	30
EXAMPLE Of APPLICATION CIRCUIT (Paralel interface, BTL output)	31
EXAMPLE Of APPLICATION CIRCUIT (Serial interface, single-end output)	32
EXAMPLE Of APPLICATION CIRCUIT (Paralel interface, BTL output)	33
PACKAGE DIMENSIONS	34
Revision History	35

(1) SERIAL INTERFACE

BLOCK DIAGRAM

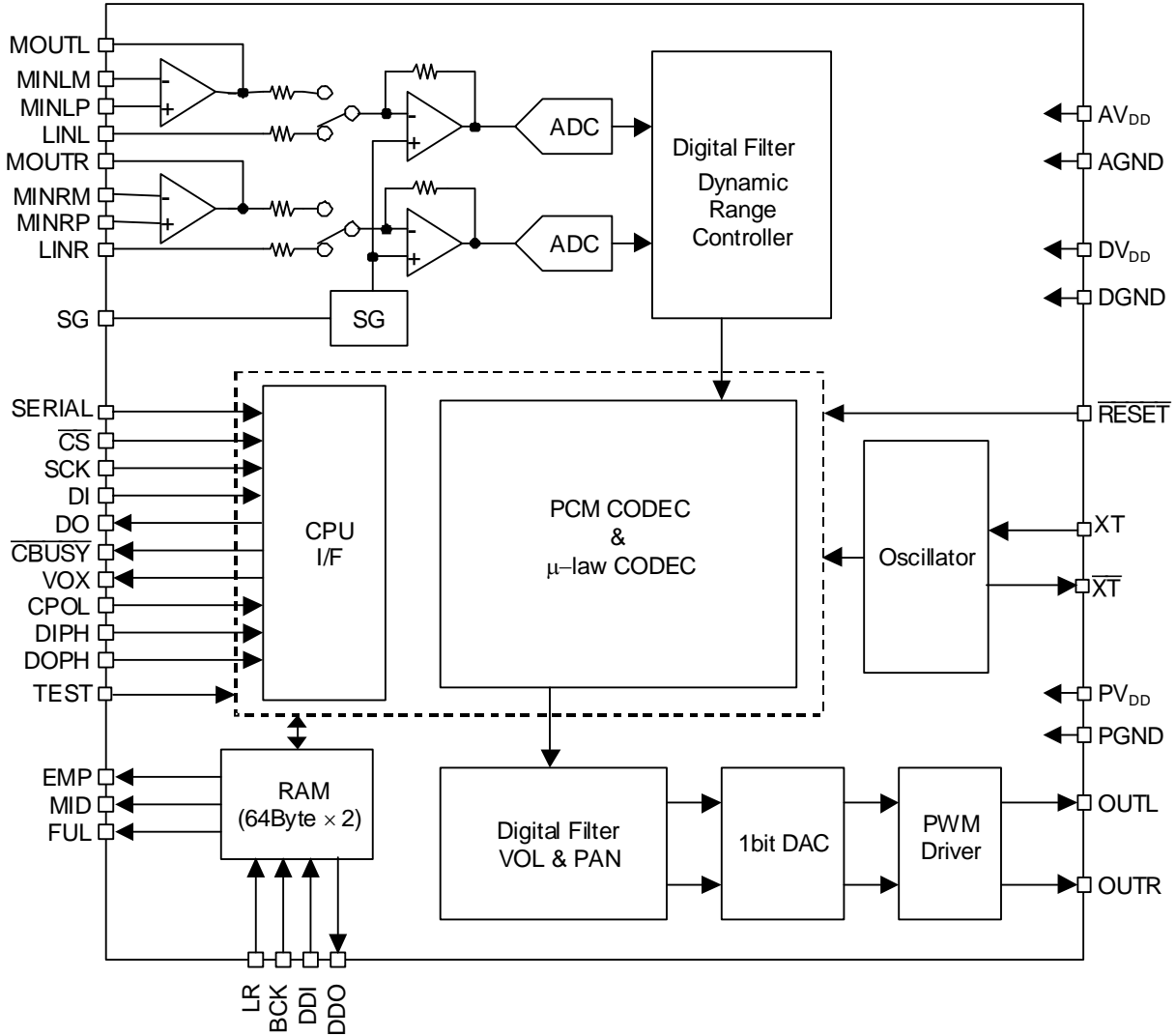

PIN CONFIGURATION (TOP VIEW)

48-pin plastic VQFN (Serial interface)

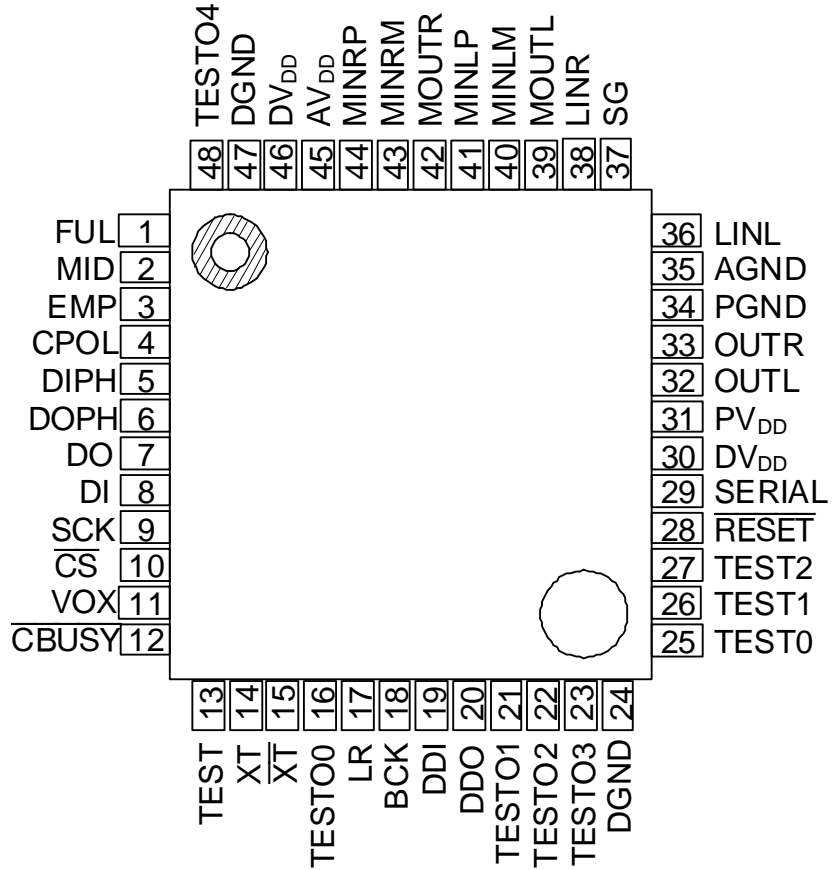

DESCRIPTION OF PINS

Command Interface Related Pins

Pin number	Pin name	I/O	Description
28	$\overline{\text{RESET}}$	I	The reset input pin. At "L" level input, the LSI is initialized. At that time, oscillation is stopped and the power is shut off. When turning the power on, input at the "L" level, and change to the "H" level once the supplied power voltage has been stabilized.
29	SERIAL	I	The parallel/serial interface select pin. Fixed to "H" level when the serial interface is selected.
10	$\overline{\text{CS}}$	I	The chip select input pin. At "L" level input, the command interface for the SCK, DI, and DO pins is enabled. It's unable to use $\overline{\text{CS}}$ pin fixed "L" level. CS pin should be "H" level after transferring 8bits command data.
9	SCK	I	The command data input and status output serial clock input pin.
8	DI	I	The command data serial data input pin.
7	DO	O	The serial data output pin. The status signal in the LSI is output as a serial data, when a command is input subsequently following the input of the RDSTAT command.
4	CPOL	I	The pin to select the input pulse polarity of the SCK pin. When the CPOL pin is at the "L" level, the SCK will become "H" active. When the CPOL pin is at the "H" level, the SCK will become "L" active.
5	DIPH	I	The edge of the SCK pulse, at which data input at the DI pin is taken in the LSI, is selected with this pin. When the DIPH pin is at the "L" level, the data input at the DI pin is taken in the LSI at the rising edge of the SCK pulse. When the DIPH pin is at the "H" level, the data input at the DI pin is taken in the LSI at the falling edge of the SCK pulse.
6	DOPH	I	The edge of the SCK pulse, at which data is output to the DO pin, is selected with this pin. When the DOPH pin is at the "L" level, data is output to the DO pin at the falling edge of the SCK pulse. When the DOPH pin is at the "H" level, data is output to the DO pin at the rising edge of the SCK pulse.
12	$\overline{\text{CBUSY}}$	O	This pin outputs data at "L" level during command processing. Commands should be input with the $\overline{\text{CBUSY}}$ pin at the "H" level.
11	VOX	O	The audio level detect signal output pin for recording. After recording has started, this pin outputs "H" once the recording input signal amplitude reaches the prescribed level.

Audio Interface Related Pins

Pin number	Pin name	I/O	Description
17	LR	I	<p>This pin inputs the left or right side channel select signal for writing the audio data in the buffer memory or reading the audio data from the buffer memory.</p> <p>The outputs of the respective status signals in the buffer memory (EMP, MID and FUL) are switched by the input level of the LR pin input. Note that the status signal of the buffer memory is an output of a channel status signal that is opposite to that of the selected channel.</p> <p>[I²S format selected] When the LR pin is at the "L" level, access to the buffer memory of the left side will be permitted. The status signal of the buffer memory of the right side will be output. When the LR pin is at the "H" level, access to the buffer memory of the right side will be permitted. The status signal of the buffer memory of the left side will be output.</p> <p>[Front-aligned MSB first format selected] When the LR pin is at the "L" level, access to the buffer memory of the right side will be permitted. The status signal of the buffer memory of the left side will be output. When the LR pin is at the "H" level, access to the buffer memory of the left side will be permitted. The status signal of the buffer memory of the right side will be output.</p>
18	BCK	I	The serial clock input pin for buffer memory input and output.
19	DDI	I	This is the pin for the input of serial data to the buffer memory. Data is taken into the LSI at the rising edge of the BCK clock.
20	DDO	O	This is the pin for the output of serial data from the buffer memory. Data is output serially at the falling edge of the BCK clock.
1	FUL	O	<p>The status signal, indicating that the entire buffer memory is full of data, will be output. A "H" active or "L" active selection can be made with the OPT command.</p> <p>Recorded data after the buffer memory becomes full is not stored in the buffer memory and is discarded.</p> <p>Therefore, any data written after the buffer memory becomes full will not be played back.</p>
2	MID	O	<p>The status signal, indicating that at least half of the buffer memory is filled with data, will be output. A "H" active or "L" active selection can be made with the OPT command.</p> <p>Ordinarily, access to the buffer memory is controlled by the output of the MID pin.</p>
3	EMP	O	The status signal, indicating that there is no data in the entire buffer memory, will be output. A "H" active or "L" active selection can be made with the OPT command.

Analog, Clock or Power Supply Related Pins

Pin number	Pin name	I/O	Description
39	MOUTL	O	The output pin of the microphone amplifier on the left side.
40	MINLM	I	The inverted input pin of the microphone amplifier on the left side.
41	MINLP	I	The non-inverted input pin of the microphone amplifier on the left side.
42	MOUTR	O	The output pin of the microphone amplifier on the right side.
43	MINRM	I	The inverted input pin of the microphone amplifier on the right side.
44	MINRP	I	The non-inverted input pin of the microphone amplifier on the right side.
36	LINL	I	The input pin of the line amplifier on the left side.
38	LINR	I	The input pin of the line amplifier on the right side.
37	SG	O	The output pin for the reference voltage (signal ground) of the analog circuit.
33	OUTR	O	The playback output pin for the right side. An external LC filter has been configured to eliminate a high-frequency component, as the PWM pulse is output.
32	OUTL	O	The playback output pin for the left side. An external LC filter has been configured to eliminate a high-frequency component, as the PWM pulse is output.
14	XT	I	An oscillator connection pin. When using an external clock, input it from this pin.
15	\overline{XT}	O	An oscillator connection pin. When using an external clock, leave this open.
13	TEST	I	A test pin. Fix it at "L". It has a built-in pull-down resistor
25,26,27	TEST2-0	I	Test pins. Keep these pins "L" level, as these pins don't have pull-up resistors.
16,21,22,23,48	TESTO4-0	O	Test pins. Leave them open when the circuit board is connected.
30,46	DV _{DD}	—	The digital power supply pins. Connect a bypass capacitor of 0.1μF or more between these pins and the DGND pin.
24,47	DGND	—	The digital ground pins.
45	AV _{DD}	—	The analog power supply pin. Connect a bypass capacitor of 0.1μF or more between this pin and the AGND pin.
35	AGND	—	The analog ground pin.
31	PV _{DD}	—	The power supply pin for the PWM driver. Connect a bypass capacitor of 10μF or more between this pin and the PGND pin.
34	PGND	—	The ground pin for the PWM driver.

WHEN PLACING AN ORDER

Specify ML2308GD (Package: 48-pin plastic VQFN).

ABSOLUTE MAXIMUM RATINGS

Parameter	Symbol	Condition	Rating	Unit
Power supply voltage	DV _{DD}	Ta = 25°C	-0.3 to +5.0	V
Input voltage	V _{IN}	Ta = 25°C	-0.3 to DV _{DD} + 0.3	V
Power Dissipation	P _D	Ta = 25°C	890	mW
Output short current	I _{SC}	Ta = 25°C(Note 1)	10	mA
		Ta = 25°C(Note 2)	100	mA
Storage temperature	T _{STG}	—	-55 to +150	°C

Notes: 1. Applies to output pins excluding OUTL and OUTR pins.
2. Applies to OUTL and OUTR pins.

RECOMMENDED OPERATING CONDITIONS

Parameter	Symbol	Condition	Range	Unit
Power supply voltage	DV _{DD}	DGND = AGND = 0 V	2.7 to 3.6	V
Operating temperature	T _{op}	—	-20 to +70	°C
Source clock frequency	f _{OSC}	—	20 to 25	MHz

ELECTRICAL CHARACTERISTICS**DC Characteristics**

DV_{DD} = AV_{DD} = 2.7 to 3.6 V
DGND = AGND = 0 V, Ta = -20 to +70°C

Parameter	Symbol	Condition	Min.	Typ.	Max.	Unit
"H" input voltage	V _{IH}	—	DV _{DD} × 0.8	—	DV _{DD} + 0.3	V
"L" input voltage	V _{IL}	—	-0.3	—	0.6	V
"H" output voltage	V _{OH}	I _{OH} = -1 mA	DV _{DD} - 0.4	—	—	V
"L" output voltage	V _{OL}	I _{OL} = 2 mA	—	—	0.4	V
"H" input current (Note 1)	I _{IH1}	V _{IH} = DV _{DD}	—	—	10	μA
"H" input current (Note 2)	I _{IH2}	V _{IH} = DV _{DD}	0.3	—	20	μA
"H" input current (Note 3)	I _{IH3}	V _{IH} = DV _{DD}	30	—	180	μA
"L" input current (Note 4)	I _{IL1}	V _{IL} = GND	-10	—	—	μA
"L" input current (Note 2)	I _{IL2}	V _{IL} = GND	-20	—	-0.3	μA
Operating current consumption	I _{DD}	f _{OSC} = 24.576 MHz at no load	—	30	40	mA
Current consumption during power down	I _{DDs}	Ta = -20 to +50°C	—	—	20	μA
		Ta = +50 to +70°C	—	—	100	μA

Notes: 1. Applies to input pins excluding XT and TEST pins.
2. Applies to XT pin.
3. Applies to TEST pin.
4. Applies to input pins excluding XT pin.

Analog Section Characteristics

$DV_{DD} = AV_{DD} = 2.7$ to 3.6 V
 $DGND = AGND = 0$ V, $T_a = -20$ to $+70^\circ\text{C}$

Parameter	Symbol	Condition	Min.	Typ.	Max.	Unit
MIN input impedance	R_{INM}	—	1	—	—	$M\Omega$
LINL, LINR input impedance	R_{INL}	When line input is used	22	32	42	$k\Omega$
LIN1, LIN2 input amplitude	V_{LIN}	—	—	—	$0.6 \times DV_{DD}$	V_{pp}
MOUT, LOU TL, LOU TR output load resistance	R_{OUTA}	—	100	—	—	$k\Omega$
Microphone amplifier gain setting range	G_{MIC}	—	—	—	30	dB
SG output voltage	V_{SG}	—	$0.48 \times DV_{DD}$	$0.5 \times DV_{DD}$	$0.52 \times DV_{DD}$	V
SG output resistance	R_{SG}	—	12	15	18	$k\Omega$
OUTL, OUTR output power	P_{OUT}	At BTL output $R_L = 16\Omega$ $S/(N+D) \geq -20\text{dB}$	—	—	150	mW

DESCRIPTION OF FUNCTIONS

Command Interface

1. SPI mode

The ML2308 supports eight types of SPI modes as available command interface modes. These SPI modes can be selected with the CPOL pin, DIPH pin and DOPH pin. Fix the output level to “L” or “H” as the SPI mode setting cannot be changed once the power has been turned on.

Setting descriptions for the CPOL pin, DIPH pin and DOPH pin are shown below:

Pin	Input Level	Setting descriptions
CPOL	“L” level	“H” pulse is input as the SCK pulse.
	“H” level	“L” pulse is input as the SCK pulse.
DIPH	“L” level	The input data of the DI pin is taken in at the rising edge of the SCK pulse.
	“H” level	The input data of the DI pin is taken in at the falling edge of the SCK pulse.
DOPH	“L” level	Data is output to the DO pin at the falling edge of the SCK pulse.
	“H” level	Data is output to the DO pin at the rising edge of the SCK pulse.

Timing diagrams of respective SPI modes are shown below:

- CPOL = “L”, DIPH = “L”, DOPH = “L”

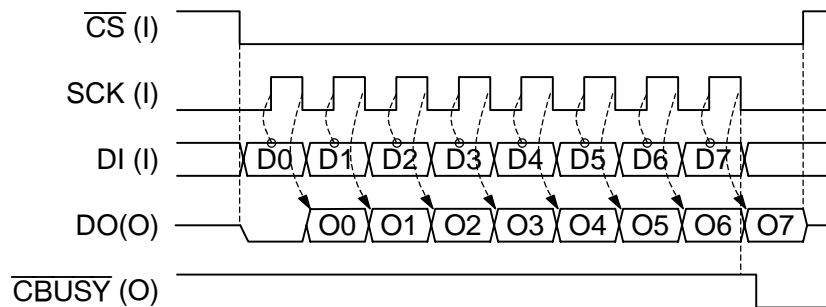

- CPOL = “L”, DIPH = “L”, DOPH = “H”

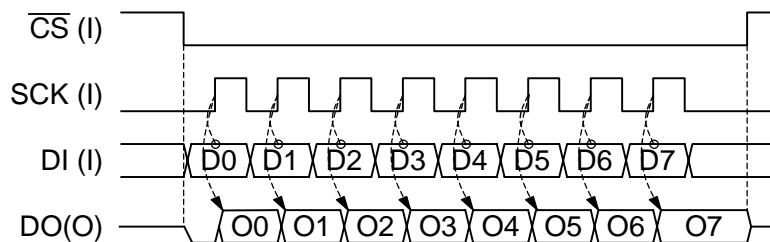

- CPOL = “L”, DIPH = “H”, DOPH = “L”

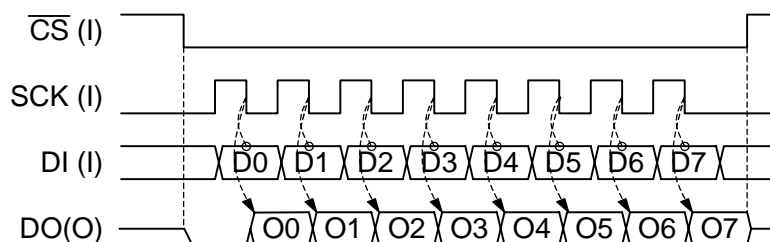

- CPOL = "L", DIPH = "H", DOPH = "H"

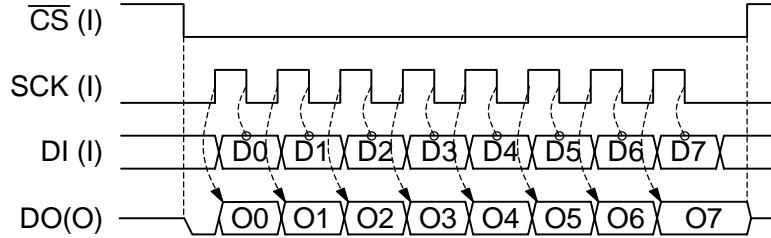

- CPOL = "H", DIPH = "L", DOPH = "L"

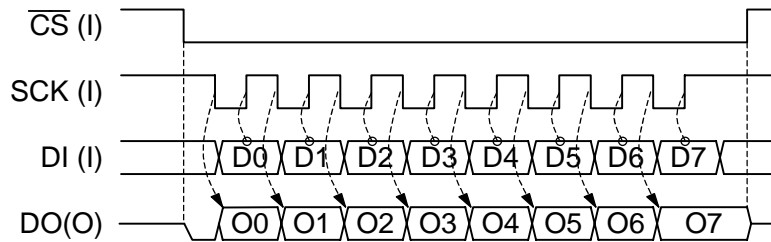

- CPOL = "H", DIPH = "L", DOPH = "H"

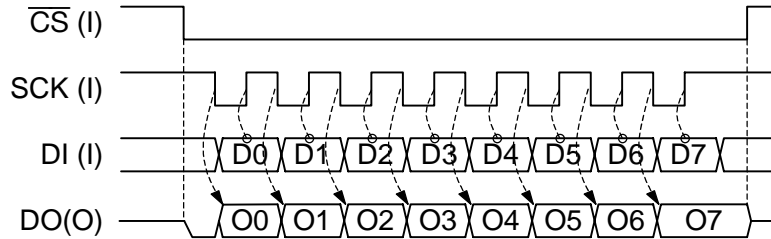

- CPOL = "H", DIPH = "H", DOPH = "L"

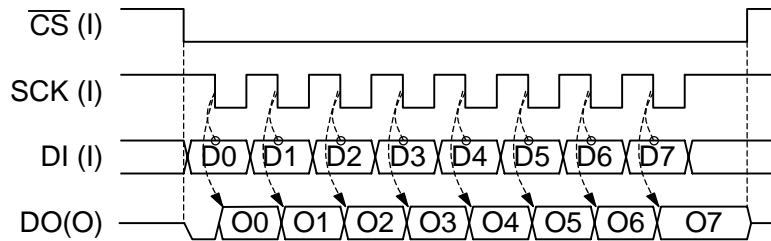

- CPOL = "H", DIPH = "H", DOPH = "H"

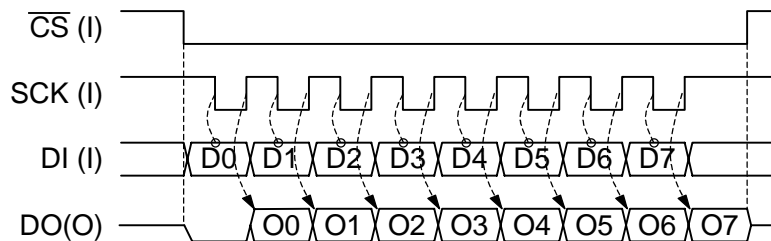

2. Command Data Write Timing

The timing for writing command data is shown below.

After “L” is input to the \overline{CS} pin, 8-bit command data is input to the DI pin serially from the LSB, synchronized with the input clock signal of the SCK pin. After 8 SCK clock signals have been input, “L” is output to the \overline{CBUSY} pin. While the \overline{CBUSY} pin is “L”, the serial interface cannot be used. It waits for the \overline{CBUSY} pin output to become “H” before inputting the next command data. Please change \overline{CS} pin to “H” level after one command inputted.

A timing diagram for the case where the CPOL pin is set at the “H” level and the DIPH pin is set at “L” level is shown below.

The “L” level output time of the \overline{CBUSY} pin, t_{CBSY} , varies depending on the operating state of the LSI.

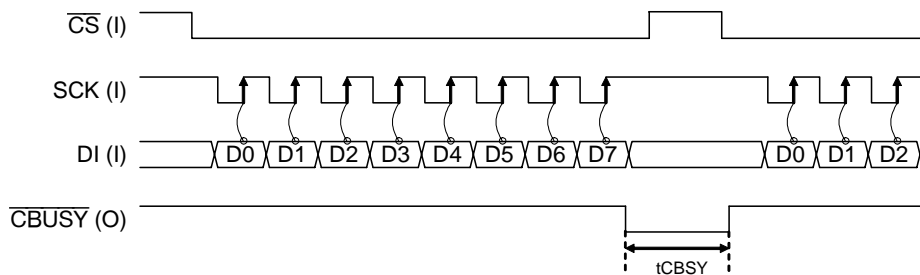

3. Status Read Timing

The timing for reading status signals is shown below.

After “L” is input to the \overline{CS} pin and the status read command (RDSTAT command) is input, 8-bit status data is output to the DO pin serially from the LSB synchronized with the falling edge of the input clock signal of the SCK pin.

A timing diagram for the case where the CPOL pin is set at the “H” level, the DIPH pin at “L” level, and the “DOPH” at the “L” level is shown below.

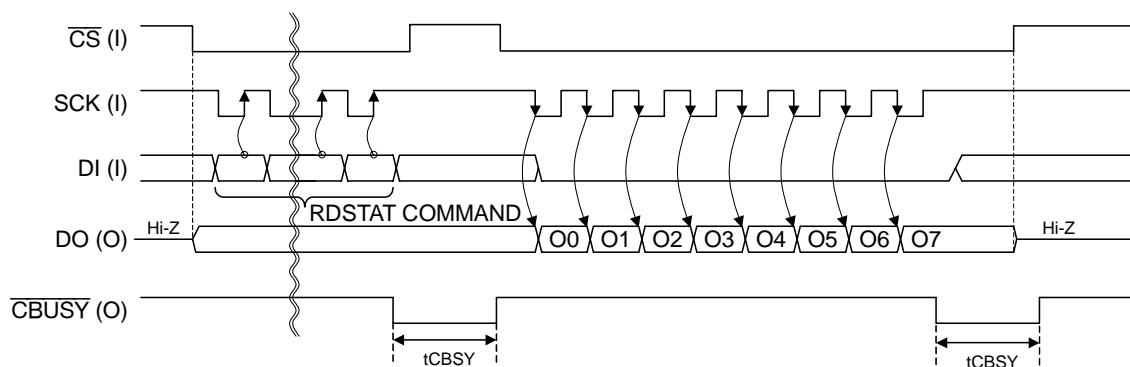

Audio Interface

The audio interface is used to write the audio data into and read the audio data out of the buffer memory during recording and playback.

As an audio interface, the ML2308 supports two types of interface formats (I²S format and front-aligned MSB first format).

Access to the buffer memory is made from the LR pin, BCK pin, DDI pin and DDO pin regardless of the selected format.

1. At I²S Formatting

Access timing to the buffer memory with the I²S format is shown below:

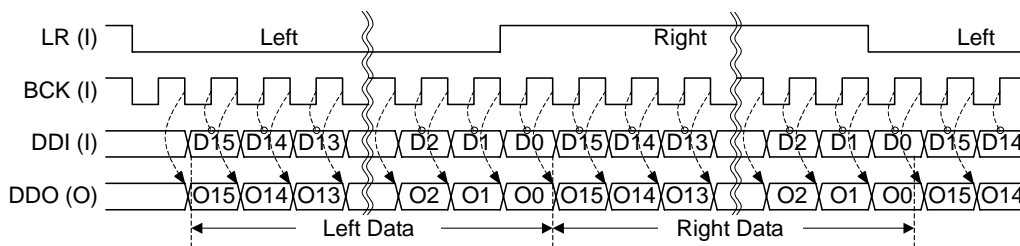

During playback, the 16-bit playback data is input serially from the MSB to the DDI pin in synchronization with the clock signal of the BCK pin. The DDI pin input data is taken in the LSI at the rising edge of the BCK clock signal. The recording data is output from the DDO pin at the falling edge of the BCK clock signal during recording.

The left side data is input and output when the level of the LR pin is at “L” and the right side data is input and output when the level of the LR pin is at “H”.

The status signal output (EMP, MID and FUL) of the buffer memory is also switched according to the input level of the LR pin. The right side status data is output when the level of the LR pin is at “L” and the left side status signal is output when the level is at “H”. Note that the status of the opposite channel is output when compared with the input and output of the data.

When the buffer memory is empty, the read data will be 0000h (hexadecimal) if reading is performed.

If the BCK clock signal is input for the duration of 16 clocks or more while the LR pin is at “H” or “L”, then the 16-bit front-aligned data will become valid data.

The buffer memory access timing, when the BCK clock is 16-bit or more, is shown below:

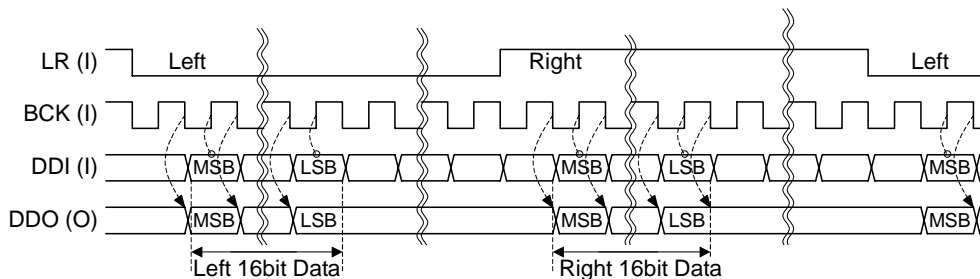

It is necessary to access both the left and right sides of the buffer memory during monaural recording and playback as well. Since buffer memory access of an unused channel will be ignored, there will be no effect to the channels that are in use. The status signal of an unused channel retains the empty state, even for the status signals of the buffer memory (EMP, MID and FUL) as well.

For example, when recording with the left side channel, the audio data read from the right side channel will be 0000h (hexadecimal). When playing back, the values written in the right side of the buffer memory will be ignored.

2. At Front-Aligned MSB First Formatting

The buffer memory access timing for the front-aligned MSB first format is shown below:

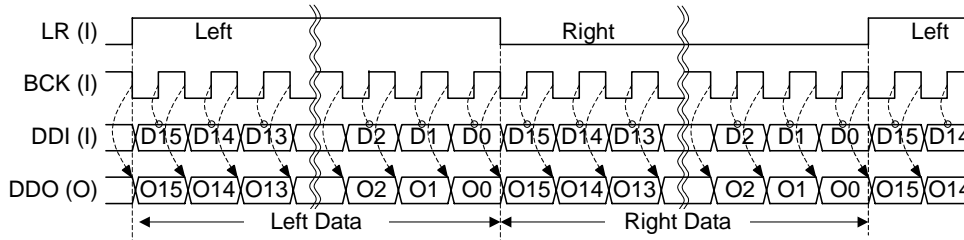

During playback, the 16-bit playback data is input serially from the MSB to the DDI pin in synchronization with the clock signal of the BCK pin. The DDI pin input data is taken in the LSI at the rising edge of the BCK clock signal. The recording data is output from the DDO pin at the falling edge of the BCK clock signal during recording.

The left side data is input and output when the level of the LR pin is at “H” and the right side data is input and output when the level of the LR pin is at “L”.

The status signal output (EMP, MID and FUL) of the buffer memory is also switched according to the input level of the LR pin. The right side status data is output when the level of the LR pin is at “H” and the left side status signal is output when the level is at “L”. Note that the status of the opposite channel is output when compared with the input and output of the data.

When the buffer memory is empty, the read data will be 0000h (hexadecimal) if reading is performed.

If the BCK clock signal is input for the duration of 16 clocks or more while the LR pin is at “H” or “L”, then the 16-bit front-aligned data will become valid data.

The buffer memory access timing, when the BCK clock is 16-bit or more, is shown below:

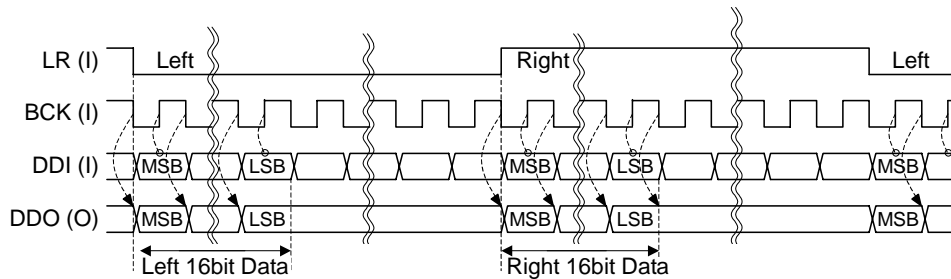

It is necessary to access both the left and right sides of the buffer memory during monaural recording and playback as well. Since buffer memory access of an unused channel will be ignored, there will be no effect to the channels that are in use. The status signal of an unused channel retains the empty state, even for the status signals of the buffer memory (EMP, MID and FUL) as well.

For example, when recording with the left side channel, the audio data read from the right side channel will be 0000h (hexadecimal). When playing back, the values written in the right side of the buffer memory will be ignored.

3. Data Configurations for Respective Audio Synthesis Methods

The configuration of the audio data that is input to and output from the buffer memory during recording and playback, for each respective audio synthesis method, is shown in the table below:

1) 2-bit ADPCM2 method

D15	D14	D13	D12	D11	D10	D9	D8
MSB1	LSB1	MSB2	LSB2	MSB3	LSB3	MSB4	LSB4
D7	D6	D5	D4	D3	D2	D1	D0
MSB5	LSB5	MSB6	LSB6	MSB7	LSB7	MSB8	LSB8

2) 3-bit ADPCM2 method

D15	D14	D13	D12	D11	D10	D9	D8
0	MSB1	2SB1	LSB1	MSB2	2SB2	LSB2	MSB3
D7	D6	D5	D4	D3	D2	D1	D0
2SB3	LSB3	MSB4	2SB4	LSB4	MSB5	2SB5	LSB5

3) 4-bit ADPCM2 method

D15	D14	D13	D12	D11	D10	D9	D8
MSB1	3SB1	2SB1	LSB1	MSB2	3SB2	2SB2	LSB2
D7	D6	D5	D4	D3	D2	D1	D0
MSB3	3SB3	2SB3	LSB3	MSB4	3SB4	2SB4	LSB4

4) 5-bit ADPCM2 method

D15	D14	D13	D12	D11	D10	D9	D8
0	MSB1	4SB1	3SB1	2SB1	LSB1	MSB2	4SB2
D7	D6	D5	D4	D3	D2	D1	D0
3SB2	2SB2	LSB2	MSB3	4SB3	3SB3	2SB3	LSB3

5) 6-bit ADPCM2 method

D15	D14	D13	D12	D11	D10	D9	D8
0	0	0	0	MSB1	5SB1	4SB1	3SB1
D7	D6	D5	D4	D3	D2	D1	D0
2SB1	LSB1	MSB2	5SB2	4SB2	3SB2	2SB2	LSB2

6) 7-bit ADPCM2 method

D15	D14	D13	D12	D11	D10	D9	D8
0	0	MSB1	6SB1	5SB1	4SB1	3SB1	2SB1
D7	D6	D5	D4	D3	D2	D1	D0
LSB1	MSB2	6SB2	5SB2	4SB2	3SB2	2SB2	LSB2

7) 8-bit ADPCM2, 8-bit straight PCM, 8-bit non-linear PCM, or μ -law PCM method

D15	D14	D13	D12	D11	D10	D9	D8
MSB1	7SB1	6SB1	5SB1	4SB1	3SB1	2SB1	LSB1
D7	D6	D5	D4	D3	D2	D1	D0
MSB2	7SB2	6SB2	5SB2	4SB2	3SB2	2SB2	LSB2

8) 16-bit straight PCM method

D15	D14	D13	D12	D11	D10	D9	D8
MSB1	15SB1	14SB1	13SB1	12SB1	11SB1	10SB1	9SB1
D7	D6	D5	D4	D3	D2	D1	D0
8SB1	7SB1	6SB1	5SB1	4SB1	3SB1	2SB1	LSB1

This concludes the descriptions on the serial interface. Refer to Section (3) for details concerning common items, such as command lists, operation flows and examples of applied circuits.

(2) PARALLEL INTERFACE

BLOCK DIAGRAM

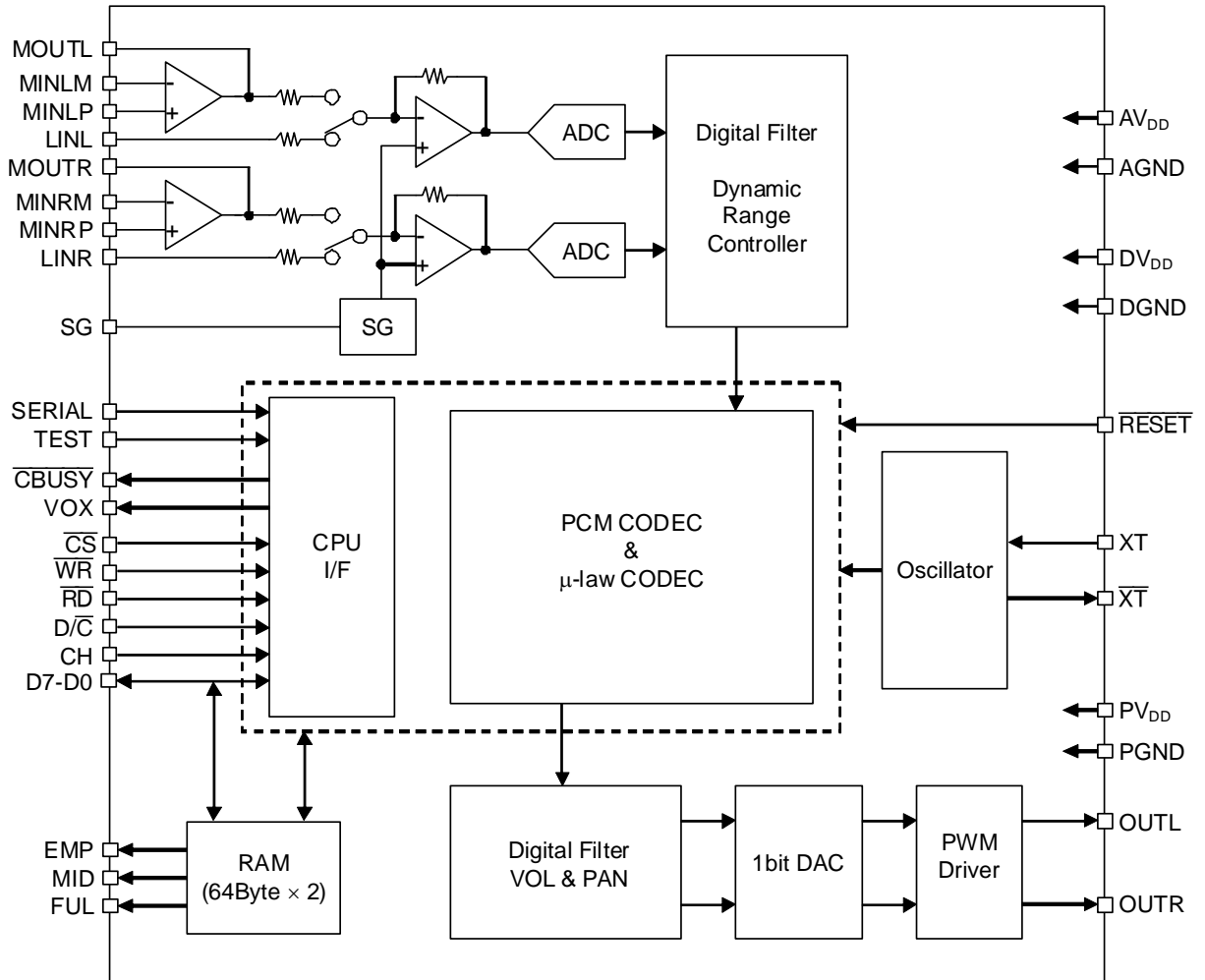

PIN CONFIGURATION (TOP VIEW)

48-pin plastic VQFN (Parallel interface)

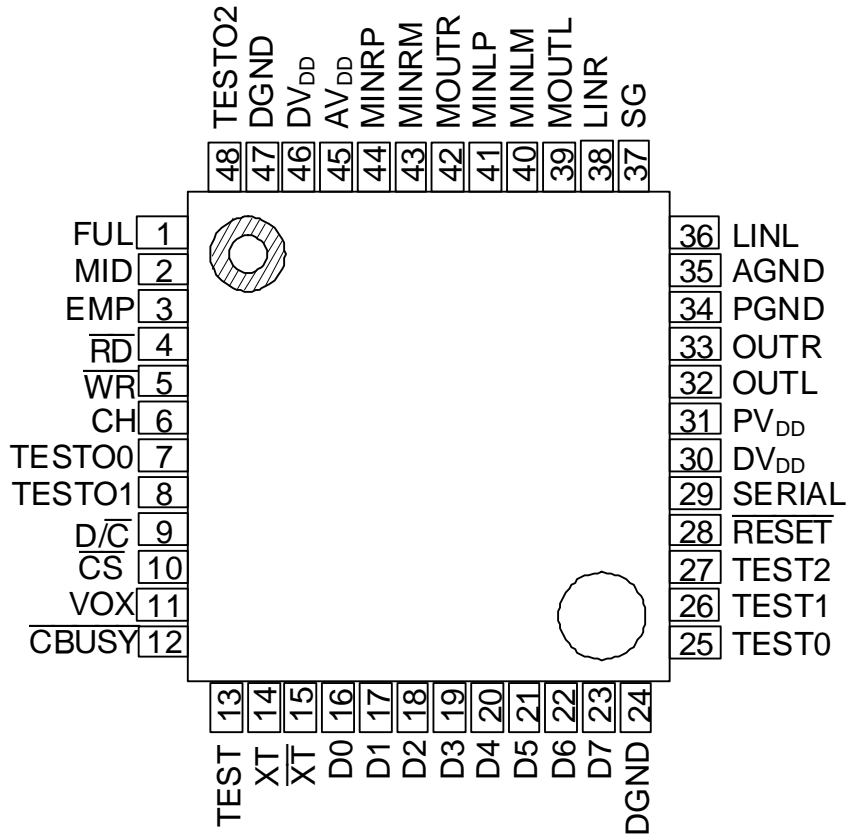

DESCRIPTION OF PINS

Command Interface Related Pins

Pin number	Pin name	I/O	Description
28	$\overline{\text{RESET}}$	I	The reset input pin. At "L" level input, the LSI is initialized. At that time, oscillation is stopped and the power is shut off. When turning the power on, input at the "L" level, and change to the "H" level once the supplied power voltage has been stabilized.
29	SERIAL	I	The CPU interface select pin. The level is fixed to "L" when the parallel interface is selected.
10	$\overline{\text{CS}}$	I	The select input pin for the command interface and the audio interface. The $\overline{\text{WR}}$ and $\overline{\text{RD}}$ inputs are accepted at the "L" level. The $\overline{\text{WR}}$ and $\overline{\text{RD}}$ signal inputs are ignored at the "H" level.
9	$\text{D}/\overline{\text{C}}$	I	The select input pin for the command interface and the audio interface. The level of the $\text{D}/\overline{\text{C}}$ pin is set to "L" and the "L" pulse is input to the $\overline{\text{WR}}$ and $\overline{\text{RD}}$ pins when inputting a command or outputting the internal status. The audio interface becomes enabled when the level is at "H".
5	$\overline{\text{WR}}$	I	The write pulse input pin. This pin is used in common by the command interface and the audio interface. [The "L" level selected for the $\text{D}/\overline{\text{C}}$ pin] The input data of the D7 to D0 pins is taken into the LSI as command data at the rising edge of the $\overline{\text{WR}}$ pin. Once the command data is taken in, the "L" level is output to the $\overline{\text{CBUSY}}$ pin, indicating that a command process is taking place. A "L" level command input of the $\overline{\text{CBUSY}}$ pin will be ignored. The command is input while the level of the $\overline{\text{CBUSY}}$ pin is at "H". [The "H" level selected for the $\text{D}/\overline{\text{C}}$ pin] Refer to the descriptions on the audio interface related pins on the next page.
4	$\overline{\text{RD}}$	I	The read pulse input pin. This pin is used in common by the command interface and the audio interface. [The "L" level selected for the $\text{D}/\overline{\text{C}}$ pin] Status data is output to the D7 to D0 pins while the level of the $\overline{\text{RD}}$ pin is at "L". In order to read the internal status, the level of the $\overline{\text{RD}}$ pin is set to "L" after the input of the RDSTAT command. Note that the status data will not be updated unless the RDSTAT command has been input. [The "H" level selected for the $\text{D}/\overline{\text{C}}$ pin] Refer to the descriptions on the audio interface related pins on the next page.
16-23	D7-D0	I/O	Data is input or output with the bi-directional data bus. These pins are used in common by the command interface and the audio interface.
12	$\overline{\text{CBUSY}}$	O	This pin outputs data at "L" level during command processing. Commands can be input when the $\overline{\text{CBUSY}}$ pin is at the "H" level.
11	VOX	O	The audio level detect signal output pin for recording. After recording has started, this pin outputs "H" once the recording input signal amplitude reaches the prescribed level.

Audio Interface Related Pins

Pin number	Pin name	I/O	Description
10	\overline{CS}	I	The select input pin for the command interface and the audio interface. The \overline{WR} and \overline{RD} inputs are accepted when set to the "L" level. The \overline{WR} and \overline{RD} signal inputs are ignored when set to the "H" level.
9	D/\overline{C}	I	The select input pin for the command interface and the audio interface. When the audio data is input or output, the level of the D/\overline{C} pin is set to "H" and the "L" level pulse is input to the \overline{WR} and \overline{RD} pins. The command interface is enabled when the level is at "L".
6	CH	I	The select input pin for the audio interface channel. When the level is at "L", the buffer memory of the left side is selected and the buffer memory status of the left side is output as status output of the EMP, MID and FUL pins. When the level is at "H", the buffer memory of the right side is selected and the buffer memory status of the right side is output as status output of the EMP, MID and FUL pins.
5	\overline{WR}	I	The write pulse input pin. This pin is used in common by the command interface and the audio interface. [The "H" level selected for the D/\overline{C} pin] The input data of the D7 to D0 pins are written into the buffer memory, which has been selected with the CH pin, at the rising edge of the \overline{WR} pin. The state of the \overline{CS} pin is irrelevant. [The "L" level selected for the D/\overline{C} pin] Refer to the descriptions on the command interface related pins on the preceding page.
4	\overline{RD}	I	The read pulse input pin. This pin is used in common by the command interface and the audio interface. [The "H" level selected for the D/\overline{C} pin] While the level of the \overline{RD} pin is at "L", the data read from the buffer memory, which has been selected with the CH pin, is output to the D7 to D0 pins. [The "L" level selected for the D/\overline{C} pin] Refer to the descriptions on the command interface related pins on the preceding page.
16-23	D7-D0	I/O	Data is input or output with the bi-directional data bus. These pins are used in common by the command interface and the audio interface.
1	FUL	O	The status signal, indicating that the entire buffer memory is full of data, will be output. A "H" active or "L" active selection can be made with the OPT command. Recordings made after the buffer memory becomes full are not stored in the buffer memory and are discarded. Therefore, any data written after the buffer memory becomes full, will not be played back.
2	MID	O	The status signal, indicating that at least half of the buffer memory is filled with data, will be output. A "H" active or "L" active selection can be made with the OPT command. Ordinarily, access to the buffer memory is controlled by the output of the MID pin.
3	EMP	O	The status signal, indicating that there is no data in the entire buffer memory, will be output. A "H" active or "L" active selection can be made with the OPT command.

Analog, Clock or Power Supply Related Pins

Pin number	Pin name	I/O	Description
39	MOUTL	O	The output pin of the microphone amplifier on the left side.
40	MINLM	I	The inverted input pin of the microphone amplifier on the left side.
41	MINLP	I	The non-inverted input pin of the microphone amplifier on the left side.
42	MOUTR	O	The output pin of the microphone amplifier on the right side.
43	MINRM	I	The inverted input pin of the microphone amplifier on the right side.
44	MINRP	I	The non-inverted input pin of the microphone amplifier on the right side.
36	LINL	I	The input pin of the line amplifier on the left side.
38	LINR	I	The input pin of the line amplifier on the right side.
37	SG	O	The output pin for the reference voltage (signal ground) of the analog circuit.
33	OUTR	O	This is the playback output pin for the right side. An external LC filter has been configured to eliminate a high-frequency component, as the PWM pulse is output.
32	OUTL	O	This is the playback output pin for the left side. An external LC filter has been configured to eliminate a high-frequency component, as the PWM pulse is output.
14	XT	I	An oscillator connection pin. When using an external clock, input it from this pin.
15	\overline{XT}	O	An oscillator connection pin. When using an external clock, leave this open.
13	TEST	I	A test pin. Fix it at "L". It has a built-in pull-down resistor
25, 26, 27	TEST2-0	I	Test pins. Keep these pins "L" level, as these pins don't have pull-up resistors.
7, 8, 48	TESTO2-0	O	Test pins. Leave them open when the circuit board is connected.
30, 46	DV _{DD}	—	The digital power supply pins. Connect a bypass capacitor of 0.1 μ F or more between these pins and the DGND pin.
24, 47	DGND	—	The digital ground pins.
45	AV _{DD}	—	The analog power supply pin. Connect a bypass capacitor of 0.1 μ F or more between this pin and the AGND pin.
35	AGND	—	The ground supply pin.
31	PV _{DD}	—	The power supply pin for the PWM driver. Connect a bypass capacitor of 10 μ F or more between this pin and the PGND pin.
34	PGND	—	The ground pin for the PWM driver.

WHEN PLACING AN ORDER

Specify ML2308GD (Package: 48-pin plastic VQFN).

ABSOLUTE MAXIMUM RATINGS

Parameter	Symbol	Condition	Rating	Unit
Power supply voltage	DV _{DD}	Ta = 25°C	-0.3 to +5.0	V
Input voltage	V _{IN}	—	-0.3 to DV _{DD} + 0.3	V
Power Dissipation	P _D	Ta = 25°C	890	mW
Output short current	I _{SC}	Ta = 25°C(Note 1)	10	mA
		Ta = 25°C(Note 2)	100	mA
Storage temperature	T _{STG}	—	-55 to +150	°C

Notes: 1. Applies to output pins excluding OUTL and OTR pins.
2. Applies to OUTL and OTR pins.

RECOMMENDED OPERATING CONDITIONS

Parameter	Symbol	Condition	Range	Unit
Power supply voltage	DV _{DD}	DGND = AGND = 0 V	2.7 to 3.6	V
Operating temperature	T _{op}	—	-20 to +70	°C
Source clock frequency	f _{OSC}	—	20 to 25	MHz

ELECTRICAL CHARACTERISTICS**DC Characteristics**

DV_{DD} = AV_{DD} = 2.7 to 3.6 V
DGND = AGND = 0 V, Ta = -20 to +70°C

Parameter	Symbol	Condition	Min.	Typ.	Max.	Unit
"H" input voltage	V _{IH}	—	DV _{DD} × 0.8	—	DV _{DD} + 0.3	V
"L" input voltage	V _{IL}	—	-0.3	—	0.6	V
"H" output voltage	V _{OH}	I _{OH} = -1 mA	DV _{DD} - 0.4	—	—	V
"L" output voltage	V _{OL}	I _{OL} = 2 mA	—	—	0.4	V
"H" input current (Note 1)	I _{IH1}	V _{IH} = DV _{DD}	—	—	10	μA
"H" input current (Note 2)	I _{IH2}	V _{IH} = DV _{DD}	0.3	—	20	μA
"H" input current (Note 3)	I _{IH3}	V _{IH} = DV _{DD}	30	—	150	μA
"L" input current (Note 4)	I _{IL1}	V _{IL} = GND	-10	—	—	μA
"L" input current (Note 2)	I _{IL2}	V _{IL} = GND	-20	—	-0.3	μA
Operating current consumption	I _{DD}	f _{OSC} = 24.576 MHz at no load	—	30	40	mA
Current consumption during power down	I _{DDS}	Ta = -20 to +50°C	—	—	20	μA
		Ta = +50 to +70°C	—	—	100	μA

Notes: 1. Applies to input pins excluding XT and TEST pins.
2. Applies to XT pin.
3. Applies to TEST pin.
4. Applies to input pins excluding XT pin.

Analog Section Characteristics

$DV_{DD} = AV_{DD} = 2.7$ to 3.6 V
 $DGND = AGND = 0$ V, $T_a = -20$ to $+70^\circ\text{C}$

Parameter	Symbol	Condition	Min.	Typ.	Max.	Unit
MIN input impedance	R_{INM}	—	1	—	—	$M\Omega$
LINL, LINR input impedance	R_{INL}	When line input is used	22	32	42	$k\Omega$
LIN1, LIN2 maximum input amplitude	V_{LIN}	—	—	$0.6 \times DV_{DD}$	—	V_{PP}
MOUT, LOU TL, LOU TR output load resistance	R_{OUTA}	—	100	—	—	$k\Omega$
Microphone amplifier gain setting range	G_{MIC}	—	—	—	30	dB
SG output voltage	V_{SG}	—	$0.48 \times DV_{DD}$	$0.5 \times DV_{DD}$	$0.52 \times DV_{DD}$	V
SG output resistance	R_{SG}	—	12	15	18	$k\Omega$
OUTL, OUTR output power	P_{OUT}	At BTL output $R_L = 16\Omega$ $S/(N+D) \geq -20\text{dB}$	—	—	150	mW

(3) COMMON TO SERIAL AND PARALLEL INTERFACES

DESCRIPTION OF FUNCTIONS

Relationship between Source oscillation frequency and Sampling Frequency

The sampling frequency f_{SAM} is selected with the S3 to S0 bits of the METHOD command. Respective sampling frequencies are determined by the relational expression with the source oscillation frequency f_{OSC} , as shown below:

S3	S2	S1	S0	Relationship between f_{SAM} and f_{OSC}	Sampling Frequency when $f_{\text{OSC}} = 24.576\text{MHz}$
0	0	X	X	—	Not used
0	1	0	0	$f_{\text{SAM}}=f_{\text{OSC}}/6144$	4.0kHz
0	1	0	1	$f_{\text{SAM}}=f_{\text{OSC}}/3072$	8.0kHz
0	1	1	0	$f_{\text{SAM}}=f_{\text{OSC}}/1536$	16.0kHz
0	1	1	1	$f_{\text{SAM}}=f_{\text{OSC}}/768$	32.0kHz
1	0	0	0	$f_{\text{SAM}}=f_{\text{OSC}}/4096$	6.0kHz
1	0	0	1	$f_{\text{SAM}}=f_{\text{OSC}}/2048$	12.0kHz
1	0	1	0	$f_{\text{SAM}}=f_{\text{OSC}}/1024$	24.0kHz
1	0	1	1	—	Not used
1	1	X	X	—	Not used

Note: X means “Don’t care”.

Audio Synthesis Methods

This LSI supports four types of audio synthesis methods to meet the needs of various audio types: 2-bit/3-bit/4-bit/5-bit/6-bit/7-bit/8-bit ADPCM2, 8-bit/16-bit straight PCM, 8-bit nonlinear PCM and μ -law PCM.

2-bit/3-bit/4-bit/5-bit/6-bit/7-bit/8-bit ADPCM2

The ADPCM2 method is an audio synthesis method that achieves higher sound quality than ADPCM (Adaptive Differential Pulse Code Modulation). This method adaptively changes the quantized width Δ for each sample and codes it as 2-bit to 8-bit data. For human voices, animal cries, or natural sounds, this method allows the audio data volume to be reduced.

8-bit/16-bit Straight PCM

This method is the best of the three methods for following audio waveforms in all audio areas. It is suitable for sounds with sudden waveform changes and waveforms in pulse forms.

8-bit Nonlinear PCM

This method is for playing back audio input in the range of $7/16 DV_{\text{DD}}$ to $9/16 DV_{\text{DD}}$ as 10-bit straight PCM sound quality, and for improving the sound quality of waveforms with low amplitude.

μ -law PCM

This method is for G.711 compliant playback.

Restriction of Sampling Frequency

To record and playback by ADPCM2 method, please set the sampling frequency under 16 kHz. Noise will happen because data does not be processed normally, if the sampling frequency is set 24kHz. In addition, all sampling frequency can be used on all PCM methods.

Buffer Memory Configuration

There are two buffer memories, one for the left side and the other for the right side. The capacity of the buffer memory can be selected with the OPT command from among 512 bits, 256 bits and 128 bits. However, the memory capacity that varies from one channel to another cannot be set.

Since the buffer time varies depending on the audio synthesis method and sampling frequency used, select the buffer memory capacity in proportion to the load of the CPU for the external control. The default value is set to 512 bits.

The maximum buffer time for the buffer memory of respective audio synthesis methods, with the buffer memory capacity of 512 bits and sampling frequency of 16kHz, is shown below:

Audio Synthesis Method	Maximum Buffer Time
2-bit ADPCM2	256 samples/16kHz = 16 ms
3-bit ADPCM2	160 samples/16kHz = 10 ms
4-bit ADPCM2	128 samples/16kHz = 8 ms
5/6/7/8-bit ADPCM2 8-bit straight PCM 8-bit non-linear PCM 8-bit μ -law PCM	64 samples/16kHz = 4 ms
16-bit straight PCM	32 samples/16kHz = 2 ms

COMMAND FUNCTIONS

Command List

Command name	D7	D6	D5	D4	D3	D2	D1	D0	Function
NOOP	0	0	0	0	0	0	0	0	No function
PDWN	0	0	0	1	0	0	0	1	Power down command
REC	0	0	1	0	0	0	R	L	Recording start command
PLAY	0	0	1	1	0	0	R	L	Playback start command
STOP	0	1	0	0	0	0	R	L	Recording/playback stop command
PAUSE	0	1	0	1	0	CL	R	L	Recording/playback pause command
BPLAY	0	1	1	0	0	0	R	L	Block playback start command
	0	0	0	0	0	B2	B1	B0	
NOOP	0	1	1	1	0	0	0	0	No function
METHOD	1	0	0	0	0	0	R	L	Audio synthesis method, sampling frequency setting command
	P3	P2	P1	P0	S3	S2	S1	S0	
VOL	1	0	0	1	0	0	R	L	Volume setting command
	V7	V6	V5	V4	V3	V2	V1	V0	
PAN	1	0	1	0	0	0	R	L	Panpot setting command
	R3	R2	R1	R0	L3	L2	L1	L0	
DRC	1	0	1	1	0	0	0	0	Automatic level control setting command
	0	0	0	DR4	DR3	DR2	DR1	DR0	
ATLT	1	1	0	0	0	0	0	0	ADC attack time/release time setting command
	LT3	LT2	LT1	LT0	AT3	AT2	AT1	AT0	
RDSTAT	1	1	0	1	0	0	0	0	Status read command
OPT	1	1	1	0	0	0	0	0	Buffer memory capacity/pin status/stereo/buffer memory serial interface setting
	0	0	0	ADT	AI	M1	M0	A	
MTSPD	1	1	1	0	1	0	MS1	MS0	Transition time setting command when varying volume
OPTANA	1	1	1	1	0	0	0	0	Analog option setting command
	OP7	OP6	OP5	OP4	OP3	OP2	OP1	OP0	

POWER SUPPLY WIRING

The power supply of the ML2308 is divided into the following three supplies

- Digital power supply (DV_{DD})
- Analog power supply for analog circuits (AV_{DD})
- Analog power supply for audio output driver (PV_{DD})

Supply DV_{DD} , PV_{DD} , and AV_{DD} from the same power supply and divide the wiring for the analog and digital systems as shown below.

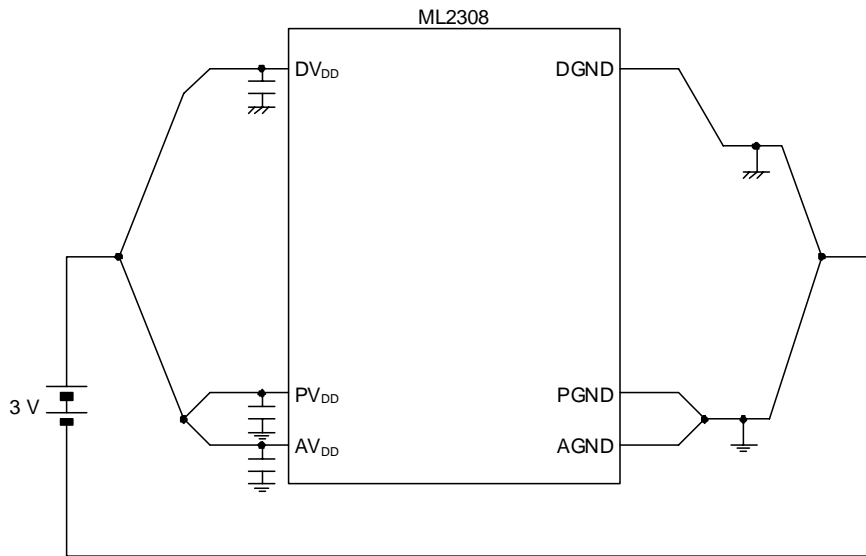

Do not arrange the wiring as shown below.

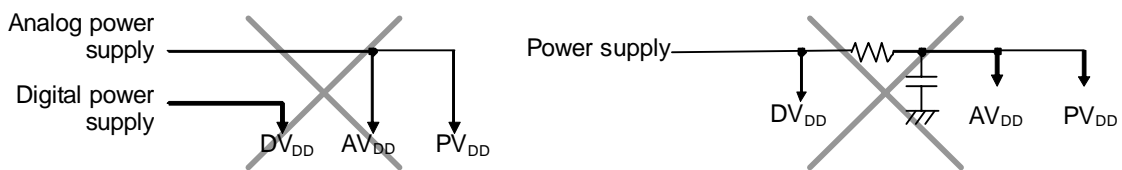

EXAMPLE OF APPLICATION CIRCUIT (PARALEL INTERFACE, SINGLE-END OUTPUT)

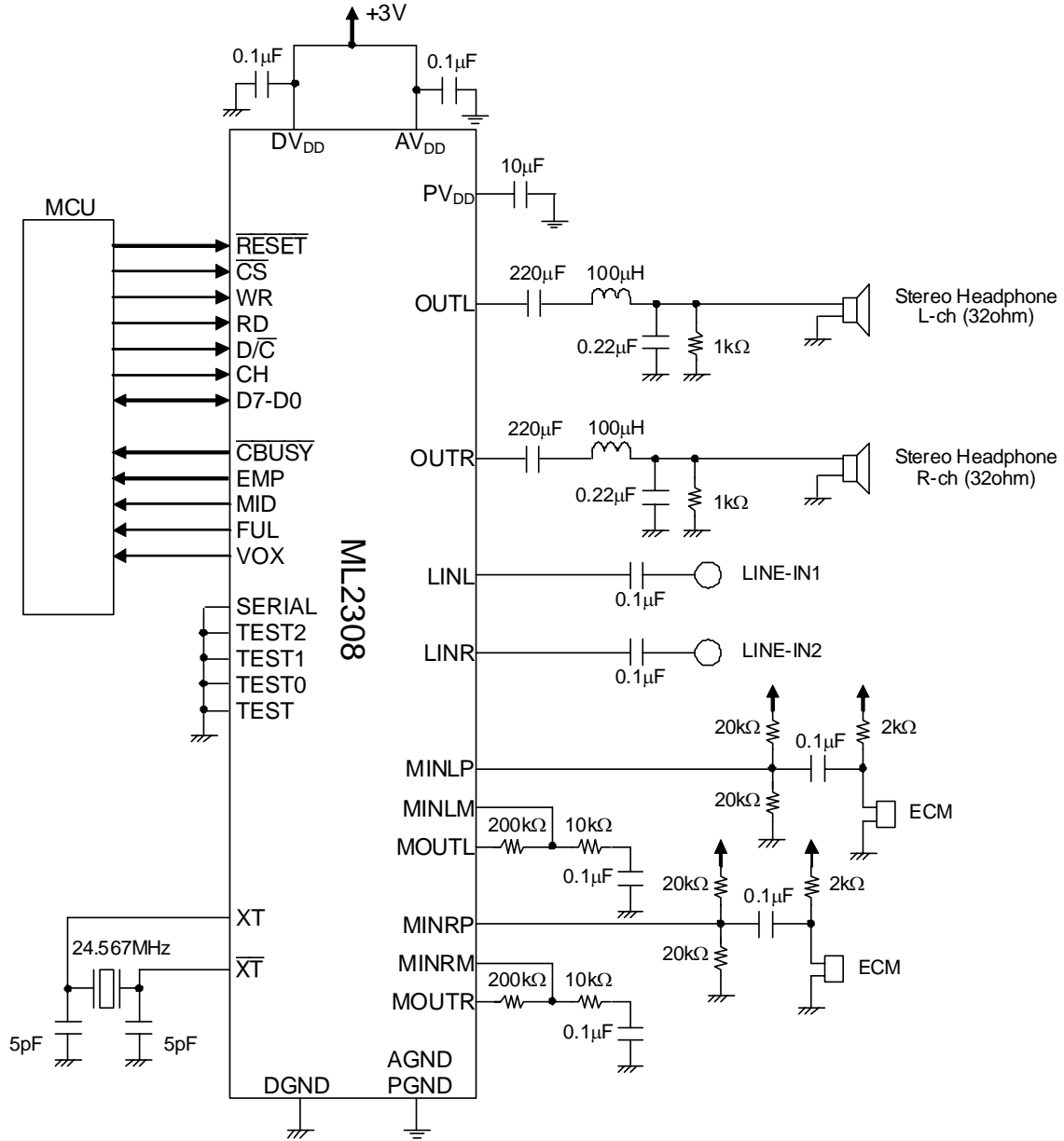

EXAMPLE OF APPLICATION CIRCUIT (PARALEL INTERFACE, BTL OUTPUT)

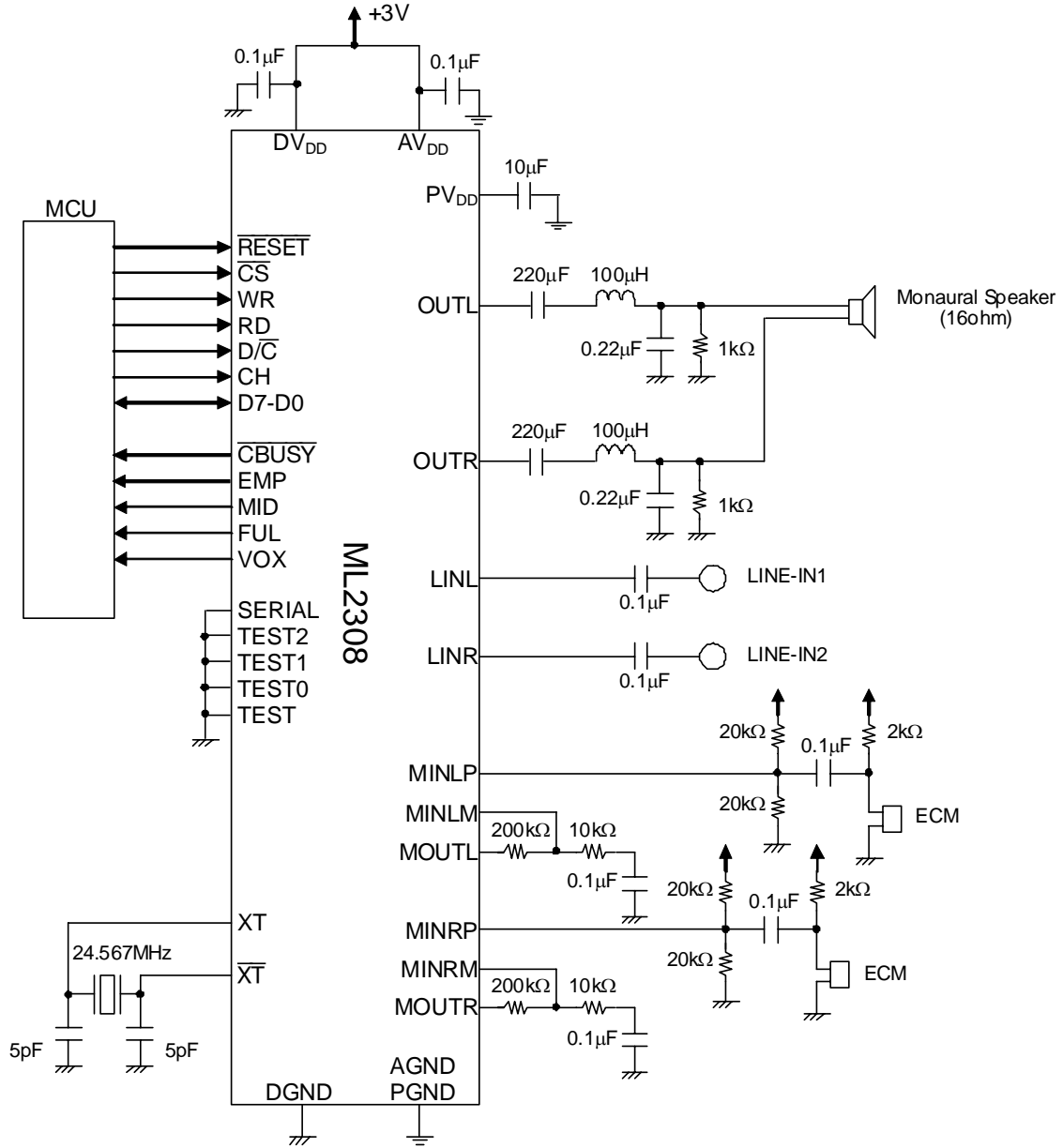

EXAMPLE OF APPLICATION CIRCUIT (SERIAL INTERFACE, SINGLE-END OUTPUT)

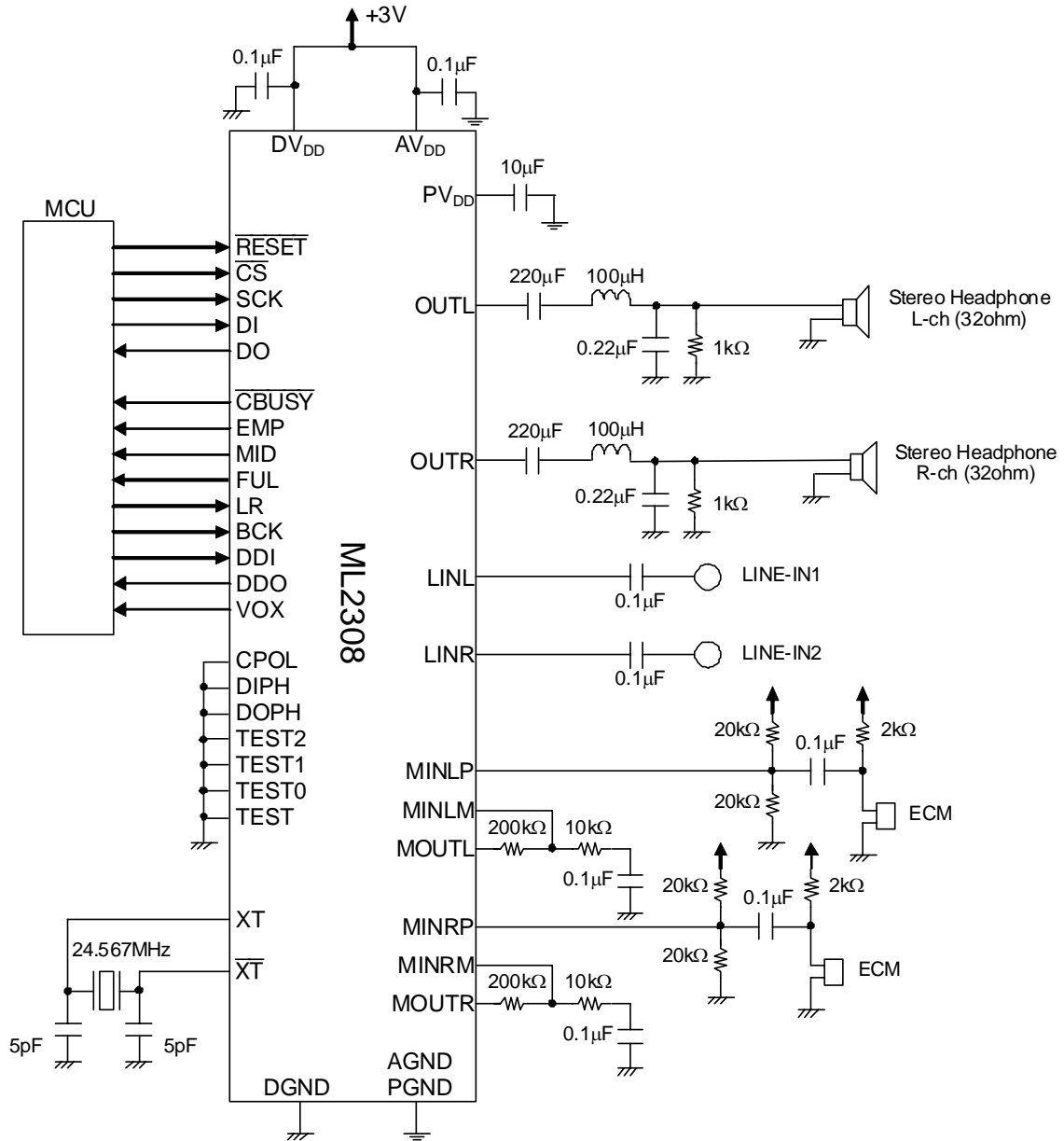

EXAMPLE OF APPLICATION CIRCUIT (PARALEL INTERFACE, BTL OUTPUT)

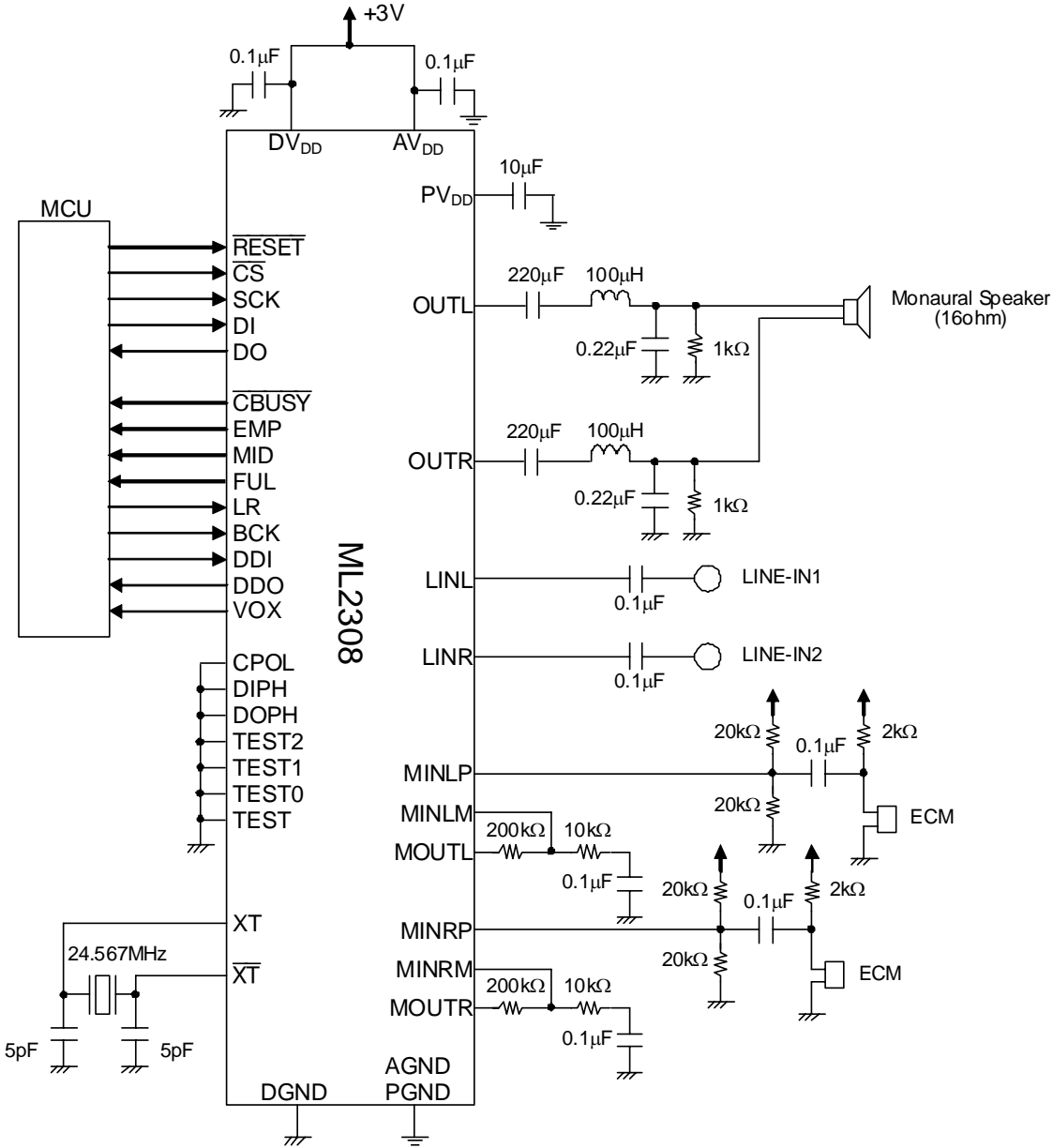

PACKAGE DIMENSIONS

(Unit: mm)

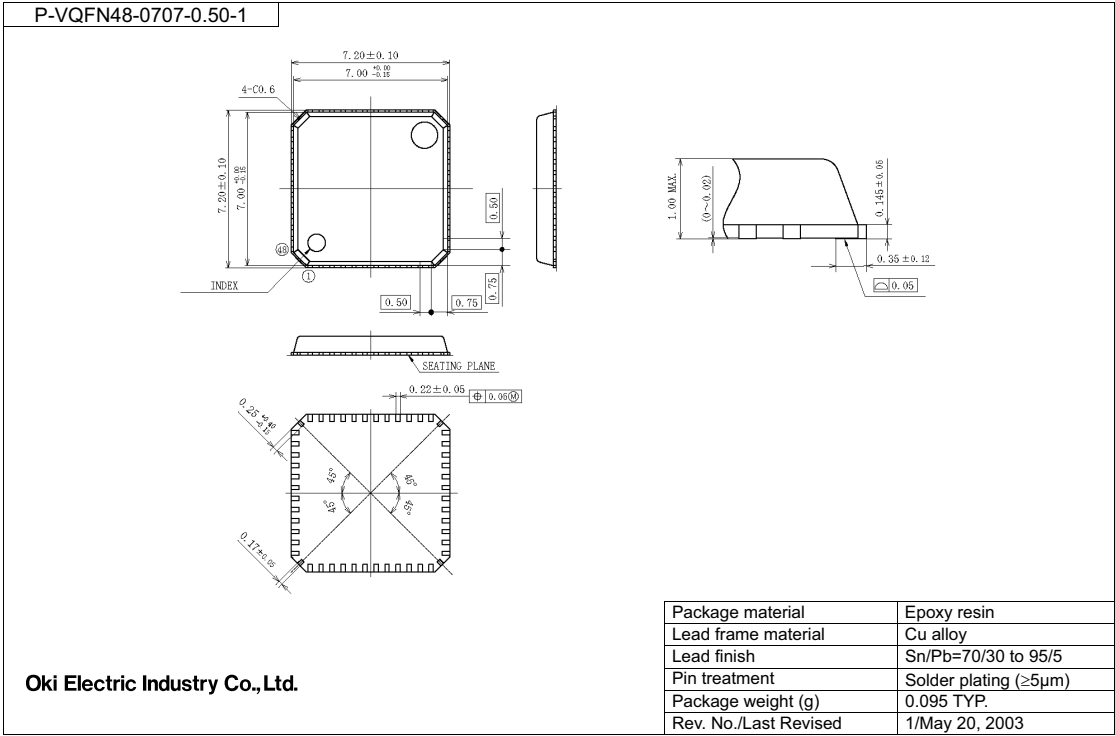

OkI Electric Industry Co.,Ltd.

Notes for Mounting the Surface Mount Type Package

The surface mount type packages are very susceptible to heat in reflow mounting and humidity absorbed in storage. Therefore, before you perform reflow mounting, contact Oki’s responsible sales person for the product name, package name, pin number, package code and desired mounting conditions (reflow method, temperature and times).

REVISION HISTORY

Document No.	Date	Page		Description
		Previous Edition	Current Edition	
PEDL2308DIGEST-01	Aug. 9, 2004	–	–	Preliminary edition 1
PEDL2308DIGEST-02	Dec.14, 2004	–	–	Preliminary edition 2
PEDL2308DIGEST-03	Dec.27, 2004	–	–	Preliminary edition 3
FEDL2308DIGEST-01	Nov.09, 2007	–	–	Final edition 1
FEDL2308DIGEST-02	Jun.11,2008	29	29,30,31, 32	Add APPLICATION CIRCUIT information

NOTICE

1. The information contained herein can change without notice owing to product and/or technical improvements. Before using the product, please make sure that the information being referred to is up-to-date.
2. The outline of action and examples for application circuits described herein have been chosen as an explanation for the standard action and performance of the product. When planning to use the product, please ensure that the external conditions are reflected in the actual circuit, assembly, and program designs.
3. When designing your product, please use our product below the specified maximum ratings and within the specified operating ranges including, but not limited to, operating voltage, power dissipation, and operating temperature.
4. Oki assumes no responsibility or liability whatsoever for any failure or unusual or unexpected operation resulting from misuse, neglect, improper installation, repair, alteration or accident, improper handling, or unusual physical or electrical stress including, but not limited to, exposure to parameters beyond the specified maximum ratings or operation outside the specified operating range.
5. Neither indemnity against nor license of a third party's industrial and intellectual property right, etc. is granted by us in connection with the use of the product and/or the information and drawings contained herein. No responsibility is assumed by us for any infringement of a third party's right which may result from the use thereof.
6. The products listed in this document are intended for use in general electronics equipment for commercial applications (e.g., office automation, communication equipment, measurement equipment, consumer electronics, etc.). These products are not, unless specifically authorized by Oki, authorized for use in any system or application that requires special or enhanced quality and reliability characteristics nor in any system or application where the failure of such system or application may result in the loss or damage of property, or death or injury to humans.
Such applications include, but are not limited to, traffic and automotive equipment, safety devices, aerospace equipment, nuclear power control, medical equipment, and life-support systems.
7. Certain products in this document may need government approval before they can be exported to particular countries. The purchaser assumes the responsibility of determining the legality of export of these products and will take appropriate and necessary steps at their own expense for these.
8. No part of the contents contained herein may be reprinted or reproduced without our prior permission.

Copyright 2008 Oki Electric Industry Co., Ltd.