



2.8 GHz Prescaler

The MC12079 is a single modulus divide by 64, 128, 256 prescaler for low power frequency division of a 2.8 GHz (typical) high frequency input signal. Divide ratio control inputs SW1 and SW2 select the required divide ratio of ÷64, ÷128, or ÷256.

An external load resistor is required to terminate the output. A 1.2 kΩ resistor is recommended to achieve a 1.6 V_{pp} output swing, when dividing a 1.1 GHz input signal by the minimum divide ratio of 64, assuming a 12 pF load. Output current can be minimized dependent on conditions such as output frequency, capacitive load being driven, and output voltage swing required. Typical values for load resistors are included in the V_{out} specification for various divide ratios at 2.8 GHz input frequency.

- 2.8 GHz Toggle Frequency
- Supply Voltage 4.5 to 5.5 V
- Low Power 9mA Typical at V_{CC} = 5.0 V
- Operating Temperature Range of -40 to 85°C

FUNCTIONAL TABLE

SW1	SW2	Divide Ratio
H	H	64
H	L	128
L	H	128
L	L	256

NOTE: SW1 & SW2: H = V_{CC}, L = Open.

MAXIMUM RATINGS

Characteristic	Symbol	Range	Unit
Power Supply Voltage, Pin 2	V _{CC}	-0.5 to 7.0	Vdc
Operating Temperature Range	T _A	-40 to 85	°C
Storage Temperature Range	T _{stg}	-65 to 150	°C
Maximum Output Current, Pin 4	I _O	4.0	mA

NOTE: ESD data available upon request.

MC12079

MECL PLL COMPONENTS ÷64/128/256 PRESCALER

SEMICONDUCTOR TECHNICAL DATA



D SUFFIX
PLASTIC PACKAGE
CASE 751
(SO-8)

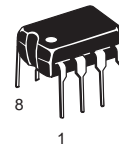

P SUFFIX
PLASTIC PACKAGE
CASE 626

PIN CONNECTIONS

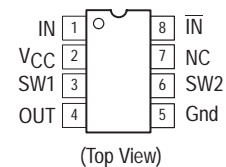

ORDERING INFORMATION

Device	Operating Temperature Range	Package
MC12079D	T _A = -40° to +85°C	SO-8
MC12079P		Plastic

MC12079

ELECTRICAL CHARACTERISTICS ($V_{CC} = 4.5$ to 5.5 V; $T_A = -40$ to 85°C , unless otherwise noted.)

Parameter	Symbol	Min	Typ	Max	Unit
Toggle Frequency (Sine Wave)	ft	0.25	3.4	2.8	GHz
Supply Current Output (Pin 2)	I_{CC}	–	9.0	11.5	mA
Input Voltage Sensitivity	V_{in}	400 100	– –	1000 1000	mVpp
Divide Ratio Control Input High (SW)	V_{IH}	V_{CC}	V_{CC}	V_{CC}	V
Divide Ratio Control Input Low (SW)	V_{IL}	Open	Open	Open	–
Output Voltage Swing	V_{out}	1.0	1.6	–	Vpp
$(C_L = 12 \text{ pF}; R_L = 1.2 \text{ k}\Omega; I_O = 2.7 \text{ mA})^1$ $(C_L = 12 \text{ pF}; R_L = 2.2 \text{ k}\Omega; I_O = 1.5 \text{ mA})^2$ $(C_L = 12 \text{ pF}; R_L = 3.9 \text{ k}\Omega; I_O = 0.85 \text{ mA})^3$					

NOTES: 1. Divide ratio of +64 at 2.8 GHz.
 2. Divide ratio of +128 at 2.8 GHz.
 3. Divide ratio of +256 at 2.8 GHz.

Figure 1. Logic Diagram (MC12079)

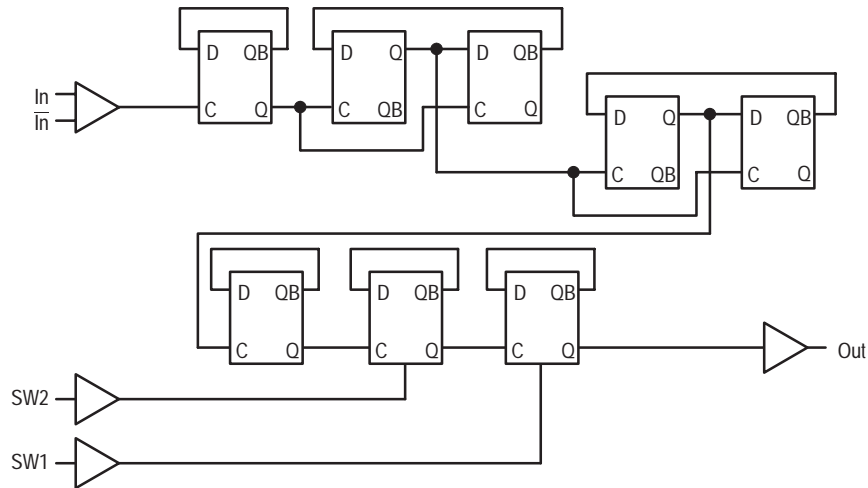
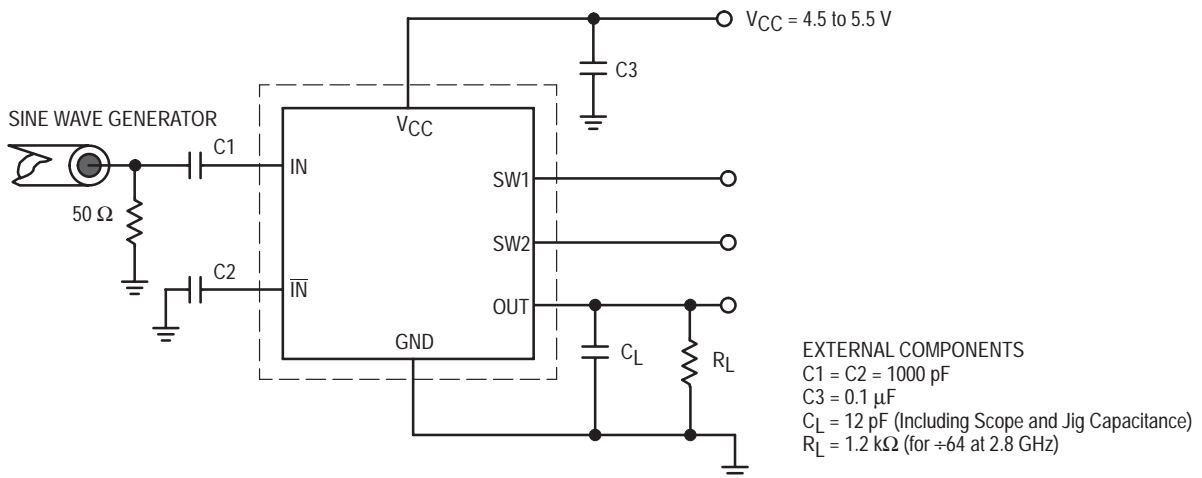
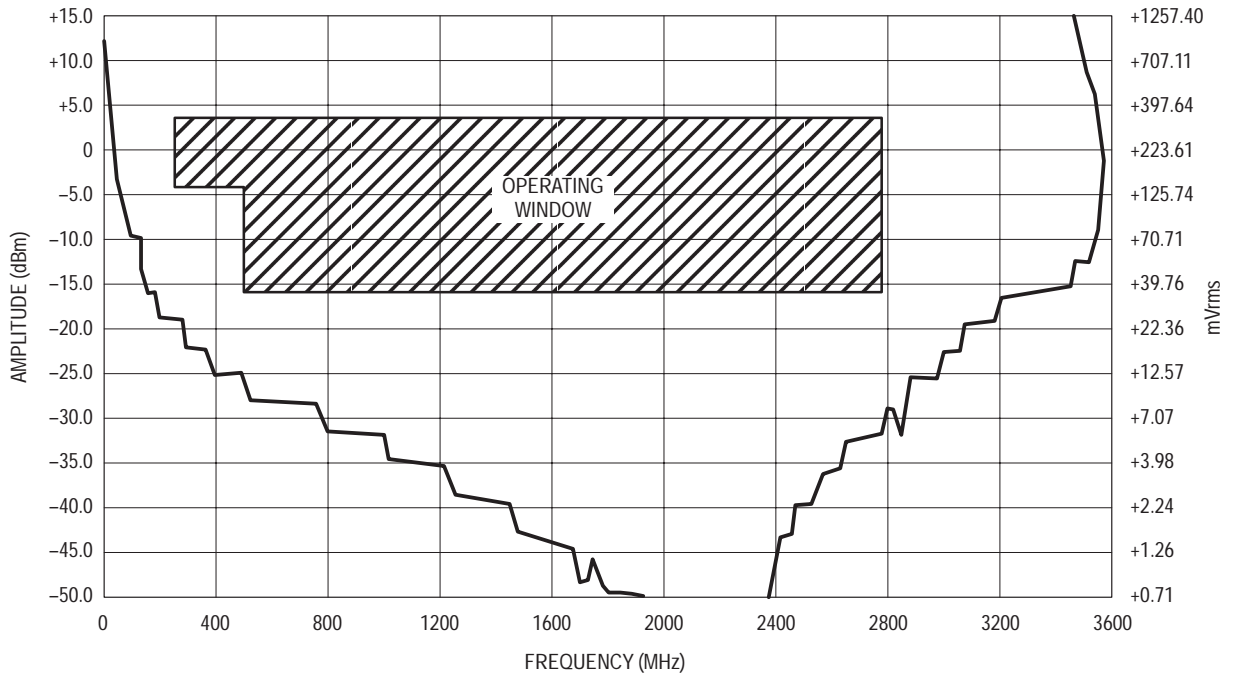

Figure 2. AC Test Circuit



MC12079

Figure 3. Input Signal Amplitude versus Input Frequency



Divide Ratio = 64; $V_{CC} = 5.0$ V; $T_A = 25^\circ\text{C}$

Figure 4. Output Amplitude versus Input Frequency

