



# LB11685VH

Monolithic Digital IC  
— 3-phase sensor less  
Motor driver

## Overview

The LB11685VH is a three-phase full-wave current-linear-drive motor driver IC. It adopts a sensor less control system without the use of a Hall Effect device. For quieter operation, the LB11685VH features a current soft switching circuit and be optimal for driving the cooling fan motors used in refrigerators, etc.

## Functions

- Three-phase full-wave linear drive (Hall sensor-less method )
- Built-in three-phase output voltage control circuit
- Built-in current limiter circuit
- Built-in motor lock protection circuit
- Motor lock protection detection output
- FG output made by back EMF
- Built-in thermal shut down circuit
- Beat lock prevention circuit

## Specifications

Maximum Ratings at Ta = 25°C

Parameter	Symbol	Conditions	Ratings	Unit
Maximum supply voltage	V <sub>CC</sub> max		19	V
Input applied voltage	V <sub>IN</sub> max		-0.3 to V <sub>CC</sub> +0.3	V
Maximum output current	I <sub>O</sub> max *1		1.2	A
Allowable power dissipation	Pd max	Mounted on a board *2	1.4	W
Operating temperature	Topr		-40 to 85	°C
Storage temperature	Tstg		-55 to 150	°C
Junction temperature	Tj max		150	°C

\*1: The I<sub>O</sub> is a peak value of motor-current.

\*2: Specified board: 76.1mm × 114.3mm × 1.6mm, glass epoxy board.

■ Any and all SANYO Semiconductor Co.,Ltd. products described or contained herein are, with regard to "standard application", intended for the use as general electronics equipment (home appliances, AV equipment, communication device, office equipment, industrial equipment etc.). The products mentioned herein shall not be intended for use for any "special application" (medical equipment whose purpose is to sustain life, aerospace instrument, nuclear control device, burning appliances, transportation machine, traffic signal system, safety equipment etc.) that shall require extremely high level of reliability and can directly threaten human lives in case of failure or malfunction of the product or may cause harm to human bodies, nor shall they grant any guarantee thereof. If you should intend to use our products for applications outside the standard applications of our customer who is considering such use and/or outside the scope of our intended standard applications, please consult with us prior to the intended use. If there is no consultation or inquiry before the intended use, our customer shall be solely responsible for the use.

■ Specifications of any and all SANYO Semiconductor Co.,Ltd. products described or contained herein stipulate the performance, characteristics, and functions of the described products in the independent state, and are not guarantees of the performance, characteristics, and functions of the described products as mounted in the customer's products or equipment. To verify symptoms and states that cannot be evaluated in an independent device, the customer should always evaluate and test devices mounted in the customer's products or equipment.

# LB11685VH

## Recommended Operating Conditions at Ta = 25°C

Parameter	Symbol	Conditions	Ratings	Unit
Recommended Supply voltage	V <sub>CC</sub>		12.0	V
Operating supply voltage	V <sub>CC op</sub>		4.5 or 18.0	V

## Electrical Characteristics at Ta = 25°C, V<sub>CC</sub> = 5.0V

Parameter	Symbol	Conditions	Ratings			Unit
			min	typ	max	
Supply current	I <sub>CC</sub>	FC1 = FC2 = 0V	5	10	20	mA
Internal regulate voltage	VREG		3.0	3.3	3.6	V
Output voltage (source)	VOSOUR	I <sub>O</sub> = 0.8A *3		1.3	1.7	V
Output voltage (sink)	VOSINK	I <sub>O</sub> = 0.8A *3		0.5	1.3	V
Current limiter	VOLIM		0.268	0.300	0.332	V
MCOM pin common-input voltage range	VINCOM		0		V <sub>CC</sub> - 2	V
MCOM pin Source current for hysteresis	ICOM+	MCOM = 7V	30		80	μA
MCOM pin Sink current for hysteresis	ICOM-	MCOM = 7V	30		80	μA
MCOM pin hysteresis current ratio	RTCOM	RTCOM = ICOM+ / ICOM-	0.6		1.4	
VCO input bias current	I <sub>VCO</sub>	V <sub>CO</sub> = 2.3V			0.2	μA
VCO oscillation minimum frequency	f <sub>VCOmin</sub>	V <sub>CO</sub> = 2.1V, CX = 0.015μF Design target *2		930		Hz
VCO oscillation maximum frequency	f <sub>VCOmax</sub>	V <sub>CO</sub> = 2.7V, CX = 0.015μF Design target *2		8.6		kHz
CX charge / discharge current	I <sub>CX</sub>	V <sub>CO</sub> = 2.5V, CX = 1.6V	70	100	140	μA
CX hysteresis voltage	ΔV <sub>CX</sub>		0.35	0.55	0.75	
C1 (C2) charge current	IC1(2)+	V <sub>CO</sub> = 2.5V, C1(2) = 1.3V	12	20	28	μA
C1 (C2) discharge current	IC1(2)-	V <sub>CO</sub> = 2.5V, C1(2) = 1.3V	12	20	28	μA
C1 (C2) charge / discharge current ratio	RTC1(2)	RTC1(2) = IC1(2)+ / IC1(2)-	0.8	1.0	1.2	
C1/C2 charge current ratio	RTCCHG	RTCCHG = IC1+ / IC2+	0.8	1.0	1.2	
C1/C2 discharge current ratio	RTCDIS	RTCDIS = IC1- / IC2-	0.8	1.0	1.2	
C1 (C2) clamp voltage width	VCW1(2)		1.0	1.3	1.6	V
FG output low level voltage	VFGL	IFG = 3mA			0.5	V
RD output low level voltage	VRDL	IRD = 3mA			0.5	v
Thermal shut down operating temperature *1	TTSD	Junction temperature Design target *2	150	180		°C
Thermal shut down hysteresis temperature *1	ΔTTSD	Junction temperature Design target *2		15		°C

\*1: The thermal shut down circuit is built-in for protection from damage of IC. But its operation is out of Topr. Design thermal calculation at normal operation.

\*2: Design target value and no measurement is made.

\*3: The I<sub>O</sub> is a peak value of motor-current.

# LB11685VH

## Package Dimensions

unit : mm (typ)  
3222A

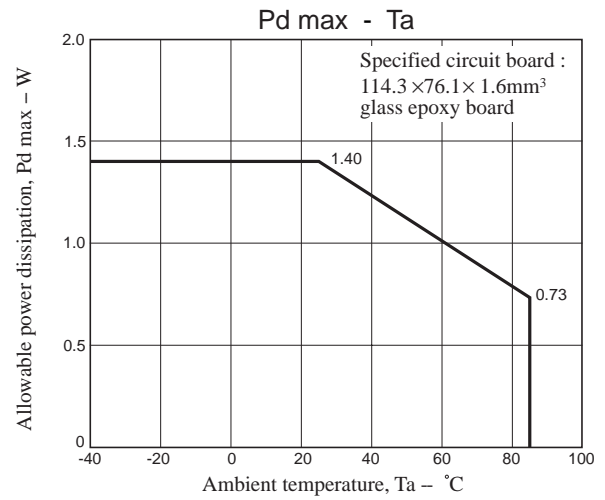
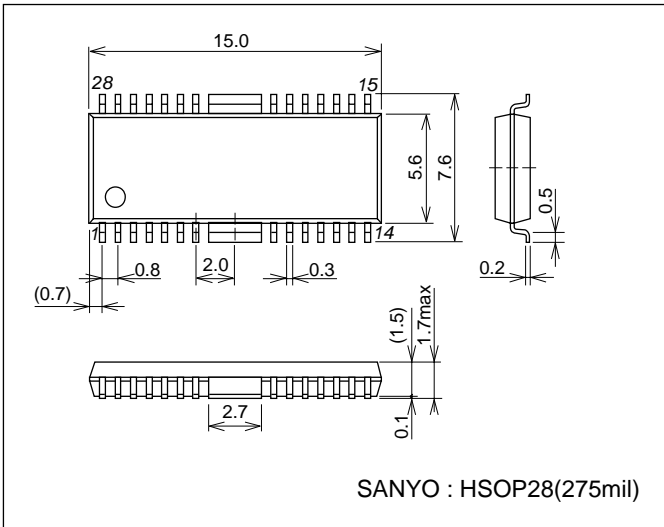

## Pin Assignment

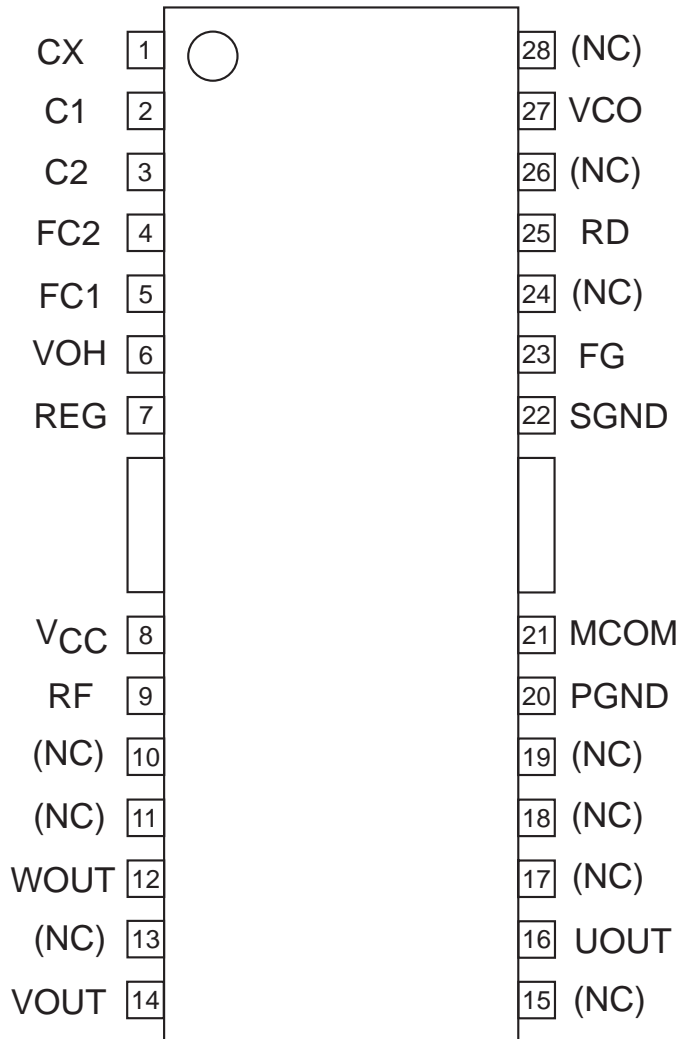

Block Diagram

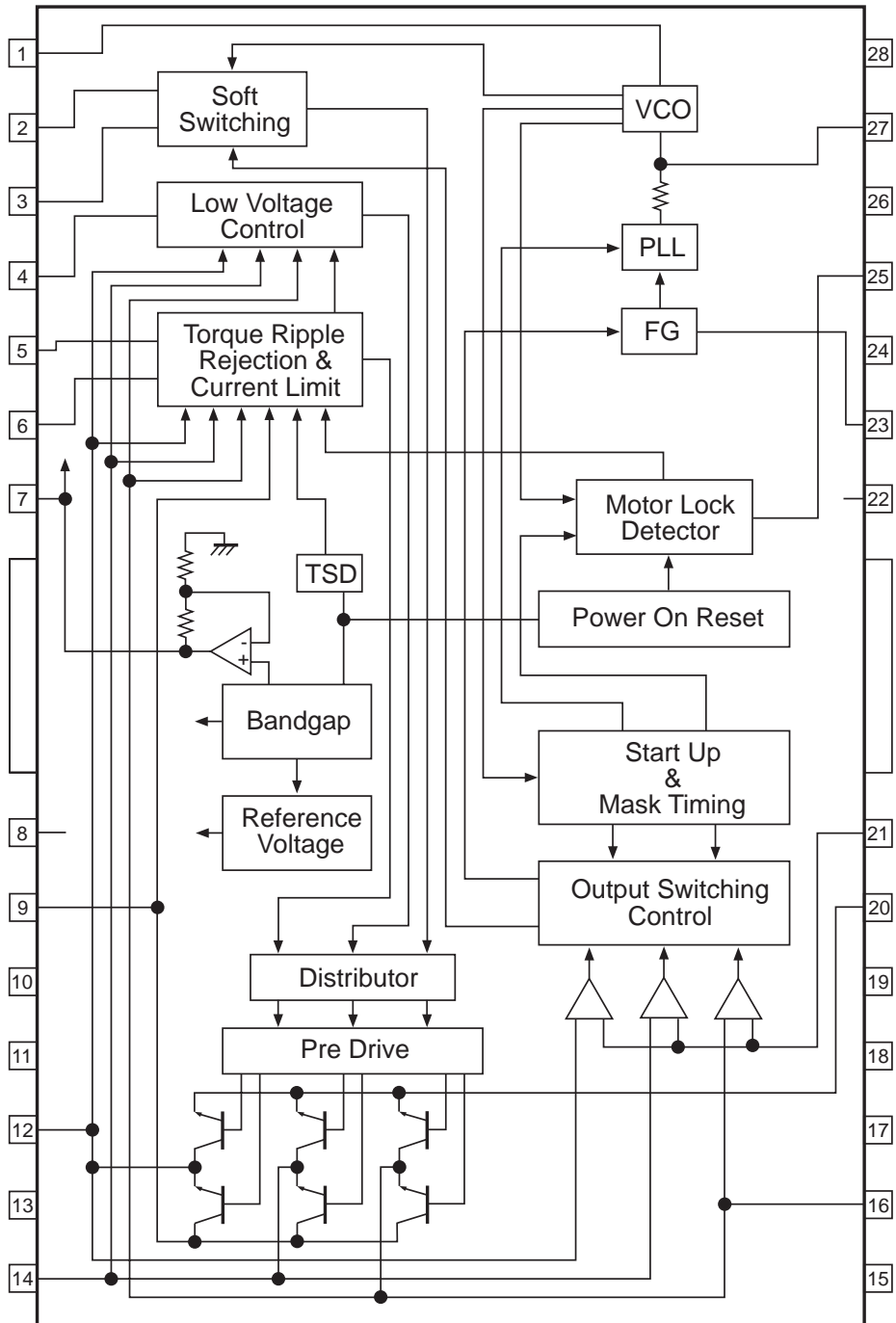

Pin Function

Pin No.	Pin name	Function	Equivalent circuit
16 12 14	UOUT WOUT VOUT	Each output pin of three phases.	
20	PGND	GND pin in the output part. This pin is connected to GND. The SGND pin is also connected to GND	
9	RF	Pin to detect output current. By connecting a resistor between this pin and V <sub>CC</sub> , the output current is detected as a voltage. The current limiter is operated by this voltage.	
21	MCOM	Motor coil midpoint input pin. The coil voltage waveform is detected based on this voltage.	
22	SGND	Ground pin (except the output part) This pin is connected to GND. The PGND pin is also connected to GND.	
23	FG	FG out made by back EMF pin. It synchronizes FG out with inverted V-phase. When don't use this function, open this pin.	
25	RD	Motor lock protection detection output pin. Output with L during rotation of motor. Open during lock protection of motor (High-impedance). When don't use this function, open this pin.	
27	VCO	PLL output pin and VCO input pin. To stabilize PLL output, connect a capacitor between this pin and GND.	
1	CX	VCO oscillation output pin. Operation frequency range and minimum frequency are determined by the capacity of the capacitor connected to this pin.	

Continue to the next page.

# LB11685VH

Continue from the former page.

Pin No.	Pin name	Function	Equivalent circuit
2 3	C1 C2	Soft switching adjustment pin. The triangular wave from is form formed by connecting a capacitor with this pin. And, the switching of three-phase output is adjusted by the slope.	
4	FC2	Frequency characteristic correction pin 2. To suppress the oscillation of control system closed loop of sink-side, connect a capacitor between this pin and GND.	
5	FC1	Frequency characteristic correction pin 1. To suppress the oscillation of control system closed loop of source-side, connect a capacitor between this pin and GND.	
6	VOH	Three-phase output high level output pin. To stabilize the output voltage of this pin, connect a capacitor between this pin and the VCC pin.	
7	VREG	DC voltage (3.3V) output pin. Connect a capacitor between this pin and GND for stabilization.	
19	VCC	Pin to supply power-supply voltage. To curb the influence of ripple and noise. The voltage should be stabilized.	

Application Circuit Example

\* Each fixed number in the following FIG, is the referential value.

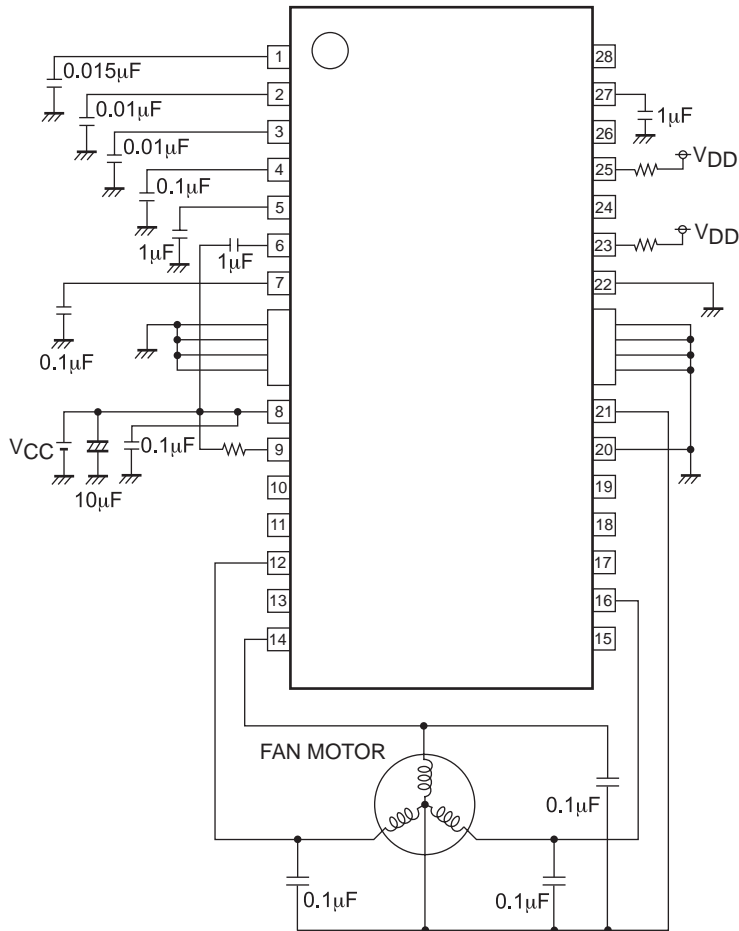

- SANYO Semiconductor Co.,Ltd. assumes no responsibility for equipment failures that result from using products at values that exceed, even momentarily, rated values (such as maximum ratings, operating condition ranges, or other parameters) listed in products specifications of any and all SANYO Semiconductor Co.,Ltd. products described or contained herein.
- SANYO Semiconductor Co.,Ltd. strives to supply high-quality high-reliability products, however, any and all semiconductor products fail or malfunction with some probability. It is possible that these probabilistic failures or malfunction could give rise to accidents or events that could endanger human lives, trouble that could give rise to smoke or fire, or accidents that could cause damage to other property. When designing equipment, adopt safety measures so that these kinds of accidents or events cannot occur. Such measures include but are not limited to protective circuits and error prevention circuits for safe design, redundant design, and structural design.
- In the event that any or all SANYO Semiconductor Co.,Ltd. products described or contained herein are controlled under any of applicable local export control laws and regulations, such products may require the export license from the authorities concerned in accordance with the above law.
- No part of this publication may be reproduced or transmitted in any form or by any means, electronic or mechanical, including photocopying and recording, or any information storage or retrieval system, or otherwise, without the prior written consent of SANYO Semiconductor Co.,Ltd.
- Any and all information described or contained herein are subject to change without notice due to product/technology improvement, etc. When designing equipment, refer to the "Delivery Specification" for the SANYO Semiconductor Co.,Ltd. product that you intend to use.
- Information (including circuit diagrams and circuit parameters) herein is for example only; it is not guaranteed for volume production.
- Upon using the technical information or products described herein, neither warranty nor license shall be granted with regard to intellectual property rights or any other rights of SANYO Semiconductor Co.,Ltd. or any third party. SANYO Semiconductor Co.,Ltd. shall not be liable for any claim or suits with regard to a third party's intellectual property rights which has resulted from the use of the technical information and products mentioned above.

This catalog provides information as of June, 2010. Specifications and information herein are subject to change without notice.