

## Film Dielectric Trimmers

**TEST VOLTAGE (DC) FOR 1 MINUTE:**

500 V

**MAXIMUM CONTACT RESISTANCE:**5 m $\Omega$ **MINIMUM INSULATION RESISTANCE:**10 000 M $\Omega$ **CATEGORY TEMPERATURE RANGE:**

- 40 to + 125 °C

**CLIMATIC CATEGORY (IEC 60068):**

40/125/21

**MINIMUM STORAGE TEMPERATURE:**

- 55 °C

**RELATED SPECIFICATION:**

IEC 60418-1 and 4

**EFFECTIVE ANGLE OF ROTATION:**

180° (rotation in 180° only, see "Life of Trimmer")

**OPERATING TORQUE:****C<sub>max</sub> = 5.5 pF**

1 to 15 mNm

**C<sub>max</sub> = 9 AND 18 pF**

1 to 20 mNm

**MAXIMUM AXIAL THRUST:**

2 N

**FEATURES**

- High temperature type
- Housing dimensions:  
8 mm x 9 mm x 10 mm
- For a basic grid of 2.54 mm
- Versions available  
with 1 or 2 rotor contacts
- Top and bottom adjustment
- Vertical version

**APPLICATIONS**

- For fine adjustment professional applications

**DESCRIPTION:**

The trimmers consist of a polysulphone housing, brass rotor and plated brass stator with PTFE film as the dielectric. The stator plate tags are heat sealed to the housing.

The rotor contact surfaces are plated to ensure a long life and a stable contact even under severe climatic conditions. A colored dot indicates the maximum capacitance.

Flux absorption between the vanes is prevented.

Cleaning with solvents is not advised.

**QUALITY LEVEL:**

Sampling and data evaluation for quality level in accordance with "MIL-STD-105D" and "IEC 60410":

< 0.15 % major defects

< 0.65 % minor defects

Each capacitor is tested for minimum C<sub>max</sub> and is also subjected to the full test voltage.

**C<sub>min</sub>/C<sub>max</sub>:**

1.4/5.5 to 3/18 pF

**RATED VOLTAGE (DC):**

250 V

**LIFE OF TRIMMER:**

Maximum 10 cycles: rotation in 180° only (the electrical and mechanical performance is not guaranteed if rotated beyond 10 cycles)

**RoHS**  
COMPLIANT

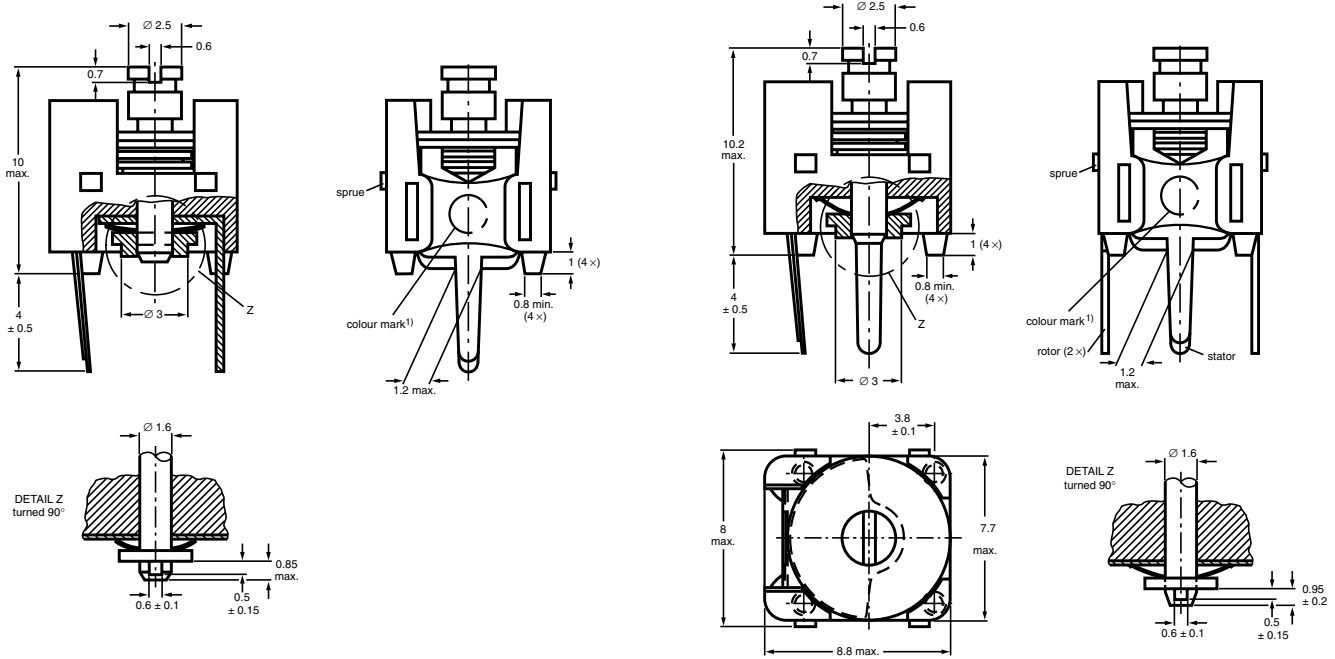

Trimmers 2281 809 090.. series, with one rotor contact

Trimmers 2281 809 090.. series, with two rotor contacts

Dimensions in millimeters

**ADJUSTMENT**

For top adjustment a screwdriver or trimming key can be used; for bottom adjustment a key is required as shown below

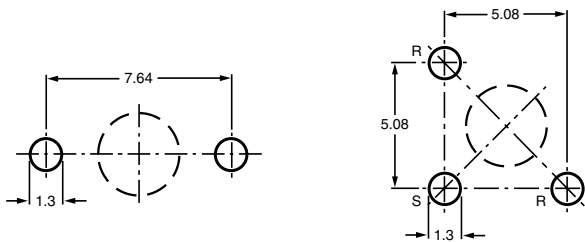

R = rotor, S = stator.

The large hole is for bottom adjustment and the diameter is determined by user's requirements

The large hole is for bottom adjustment and the diameter is determined by user's requirements

Hole pattern

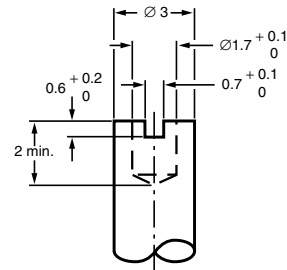

Bottom adjustment key

**MOUNTING**

The trimmer can be mounted on printed-circuit boards with a basic grid of 2.54 mm and a minimum hole diameter of 1.25 mm.

**PACKAGING**

Blister packs of 105 units each. For smallest packaging quantity (SPQ) see Electrical Data Table.

**ORDERING INFORMATION**

C <sub>min</sub> /C <sub>max</sub> (pF)	CATALOG NUMBER 2281 809 090.. OR BFC2 809 090..*	
	ROUND HEAD TOP AND BOTTOM ADJUSTMENT	
	VERSION WITH 1 ROTOR CONTACT	VERSION WITH 2 ROTOR CONTACTS
1.4/5.5	04	01
2/9	05	02
3/18	06	03

**ELECTRICAL DATA**

GUARANTEED MAX. C <sub>min</sub> / MIN. C <sub>max</sub> at 200 kHz (pF)	SHAPE OF HEAD	DIEL.	tan δ at C <sub>max</sub> X 10 <sup>-4</sup>		TEMP. COEFF. <sup>2)</sup> (10 <sup>-6</sup> /K)	MIN. f <sub>res</sub> at C <sub>max</sub> (MHz)	COL. OF DOT	SPQ	CATALOG NUMBER 2281 ... .. or BFC2 ... ..*
			1 MHz	100 MHz					
1.4/5.5	round	PTFE <sup>1)</sup>	≤ 10	≤ 15	- 250 ± 350	850	green	525	.... 809 09004 <sup>3)</sup>
	round							525	.... 809 09001 <sup>4)</sup>
2/9	round					580	white	525	.... 809 09005 <sup>3)</sup>
	round							525	.... 809 09002 <sup>4)</sup>
3/18	round					360	red	525	.... 809 09006 <sup>3)</sup>
	round							525	.... 809 09003 <sup>4)</sup>

**Notes**

1. PTFE = polytetrafluorethylene.
2. C: 60 % to 80 % of C<sub>max</sub>; T<sub>amb</sub>: from + 20 °C to + 125 °C.
3. Version with one rotor contact.
4. Version with two rotor contacts.

\* ordering code for SAP system

**TEST PROCEDURES AND REQUIREMENTS**

IEC 60418-1 CLAUSE	IEC 60068 TEST METHOD	TEST	PROCEDURE	REQUIREMENTS
4.2		method of mounting	method A	
14		capacitance drift	after TC measurement	ΔC/C: ≤ 2.0 %; ≤ 3.0 % for 9 pF;
19		thrust	axial thrust of 2 N	ΔC/C: ≤ 0.3 %
21		robustness of terminations:		
21.1	Ua	tensile	1 N	no damage
21.2	Ub	bending	1 cycle	no damage
22	Na	rapid change of temperature	1 cycle; 0.5 hours at lower and 0.5 hours at upper category temperature	ΔC/C: ≤ 3 %
23	T	soldering:		
	Ta	solderability	solder bath immersion 3 mm; 235 °C; 2 s	good wetting no mechanical damage
	Tb	resistance to heat	solder bath: 260 °C; 10 s	no mechanical damage
24	Eb	impact bump	4000 ± 10 bumps; 40 g; 6 ms	ΔC/C: ≤ 0.5 %; no mechanical damage



IEC 60418-1 CLAUSE	IEC 60068 TEST METHOD	TEST	PROCEDURE	REQUIREMENTS
25	Fc	vibration	frequency 10 to 55 Hz; amplitude 0.35 mm; 1.5 hours	$\Delta C/C: \leq 0.3 \%$ ; no mechanical damage
26 26.1	B	climatic sequence: dry heat	16 hours at upper category temperature	$\Delta C/C: \leq 2.5 \%$ $\tan \delta: \leq 10 \times 10^{-4}$ $R_{ins}: \geq 10000 \text{ M}\Omega$ ; rotor contact R: $\leq 5 \text{ m}\Omega$
26.2	D	damp heat accelerated, first cycle	1 cycle; 24 hours; + 40 °C; 95 to 100 % RH	voltage proof: 500 V for 1 minute
26.3	Aa	cold	16 hours; - 40 °C	visual examination: no mechanical damage
26.5		damp heat accelerated, remaining cycles	1 cycle; 24 hours; + 40 °C; 95 to 100 % RH	operating torque: 1 to 20 mNm
27	Ca	damp heat steady state	21 days; + 40 °C; 90 to 95 % RH	$\Delta C/C: \leq 3 \%$ $\tan \delta: \leq 10 \times 10^{-4}$ $R_{ins}: \geq 10\,000 \text{ M}\Omega$ ; rotor contact R: $\leq 5 \text{ m}\Omega$ voltage proof: 500 V for 1 minute visual examination: no mechanical damage operating torque: 1 to 20 mNm
29		mechanical endurance	10 cycles  Maximum 10 cycles: rotation in 180° only (the electrical and mechanical performance is not guaranteed if rotated beyond 10 cycles)	$\Delta C/C: \leq 3 \%$ $\Delta C/C$ after axial thrust: $\leq 0.3 \%$ ; rotor contact R: $\leq 5 \text{ m}\Omega$ voltage proof: 500 V for 1 minute visual examination: no mechanical damage operating torque: 1 to 20 mNm



## Notice

Specifications of the products displayed herein are subject to change without notice. Vishay Intertechnology, Inc., or anyone on its behalf, assumes no responsibility or liability for any errors or inaccuracies.

Information contained herein is intended to provide a product description only. No license, express or implied, by estoppel or otherwise, to any intellectual property rights is granted by this document. Except as provided in Vishay's terms and conditions of sale for such products, Vishay assumes no liability whatsoever, and disclaims any express or implied warranty, relating to sale and/or use of Vishay products including liability or warranties relating to fitness for a particular purpose, merchantability, or infringement of any patent, copyright, or other intellectual property right.

The products shown herein are not designed for use in medical, life-saving, or life-sustaining applications. Customers using or selling these products for use in such applications do so at their own risk and agree to fully indemnify Vishay for any damages resulting from such improper use or sale.