

128Kx32 EEPROM MODULE, SMD 5962-94585

FEATURES

- Access Times of 125, 140, 150, 200, 250, 300ns
- Packaging:
 - 66-pin, PGA Type, 27.3mm (1.075") square, Hermetic Ceramic HIP (Package 400)
 - 68 lead, 22.4mm sq. CQFP (G2T), 4.57mm (0.180") high, (Package 509)
- Organized as 128Kx32; User Configurable as 256Kx16 or 512Kx8
- Write Endurance 10,000 Cycles
- Data Retention Ten Years Minimum (at +25°C)
- Commercial, Industrial and Military Temperature Ranges
- Low Power CMOS
- Automatic Page Write Operation
- Page Write Cycle Time: 10ms Max
- Data Polling for End of Write Detection
- Hardware and Software Data Protection
- TTL Compatible Inputs and Outputs
- 5 Volt Power Supply
- Built-in Decoupling Caps and Multiple Ground Pins for Low Noise Operation
- Weight
 - WE128K32-XG2TX – 8 grams typical
 - WE128K32-XH1X – 13 grams typical

*This product is subject to change without notice.

FIGURE 1 – PIN CONFIGURATION FOR WE128K32N-XH1X

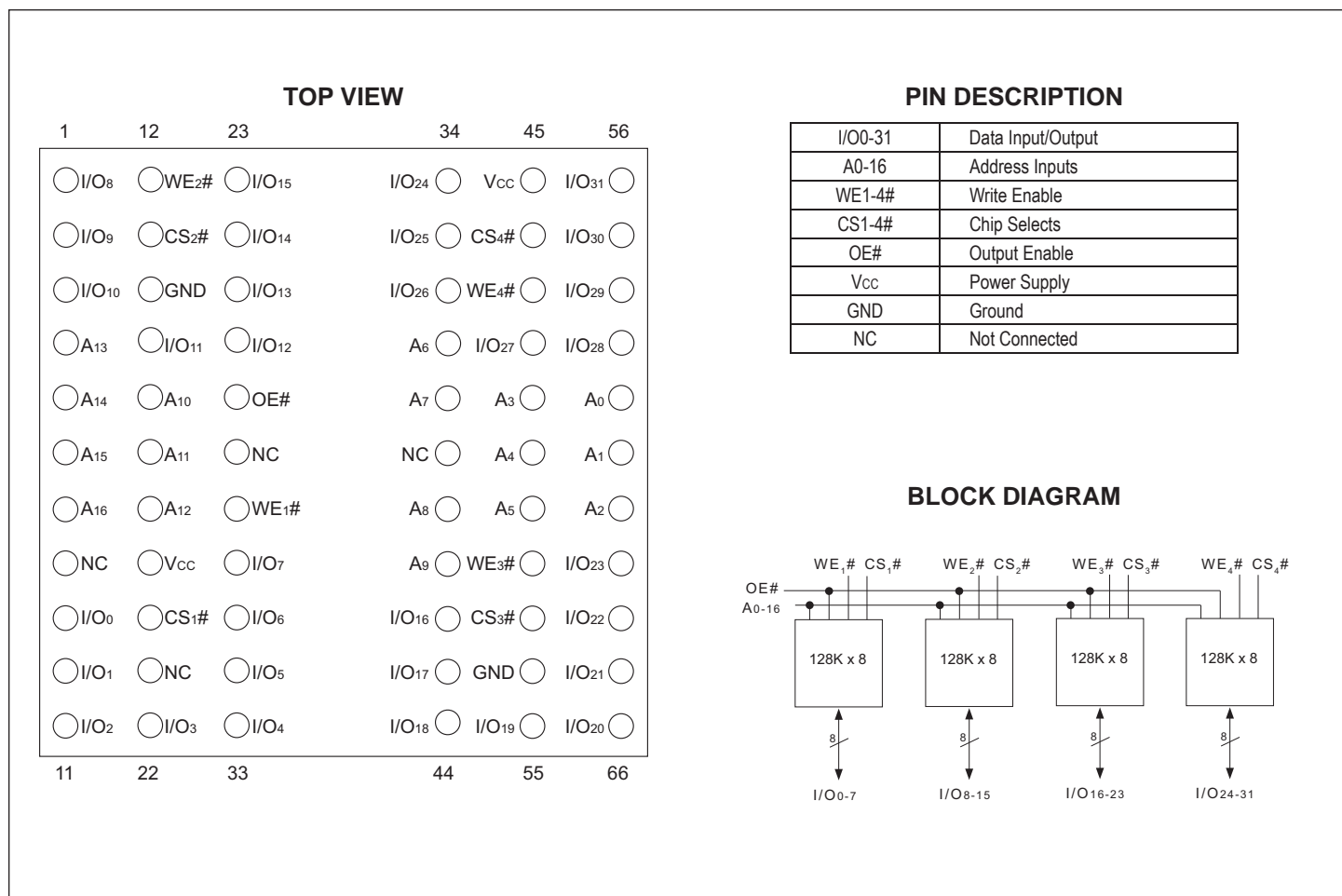
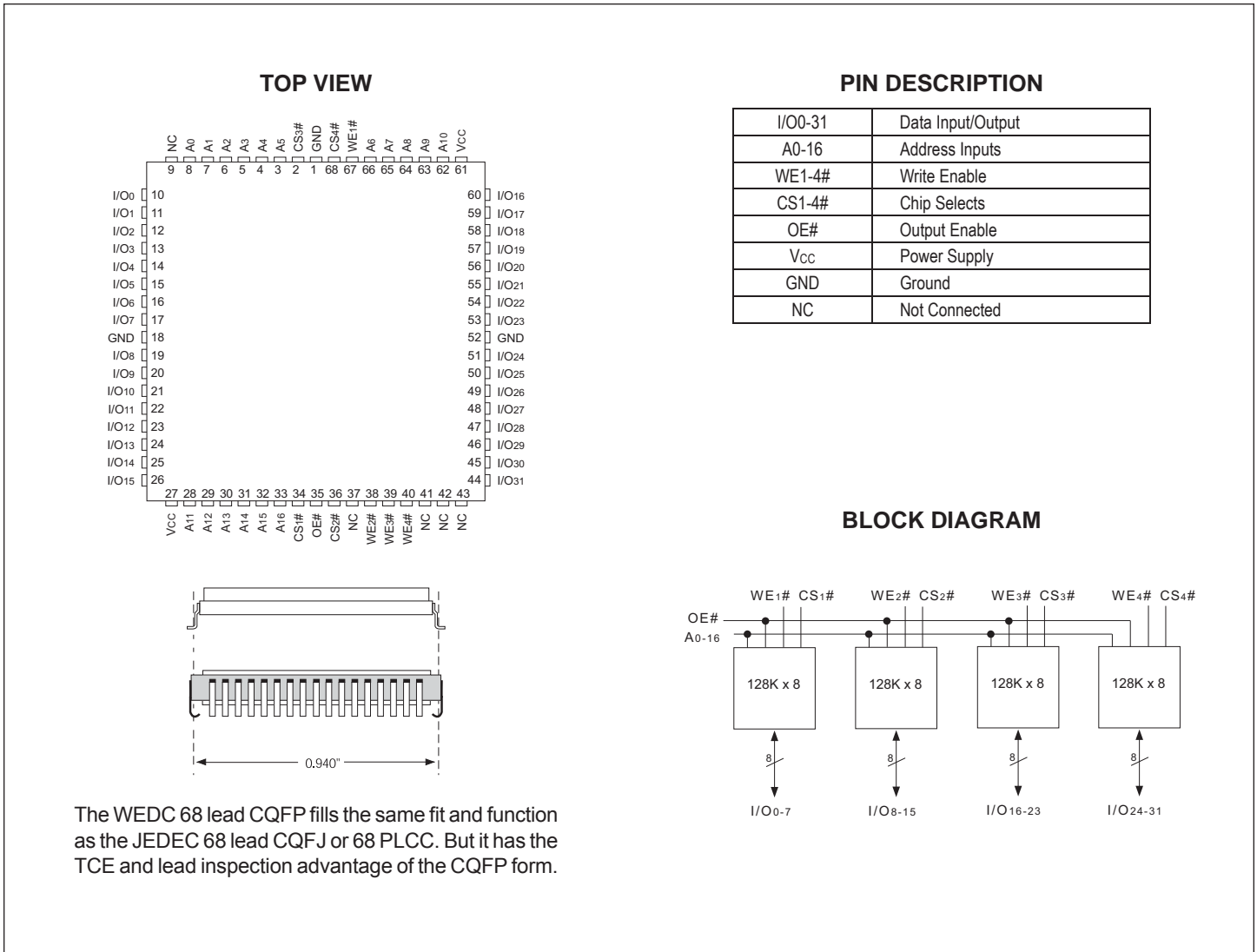

FIGURE 3 – PIN CONFIGURATION FOR WE128K32-XG2TX

ABSOLUTE MAXIMUM RATINGS

Parameter	Symbol		Unit
Operating Temperature	T_A	-55 to +125	°C
Storage Temperature	T_{STG}	-65 to +150	°C
Signal Voltage Relative to GND	V_G	-0.6 to +6.25	V
Voltage on OE# and A9		-0.6 to +13.5	V

NOTE:

Stresses above those listed under "Absolute Maximum Ratings" may cause permanent damage to the device. This is a stress rating only and functional operation of the device at these or any other conditions above those indicated in the operational sections of this specification is not implied. Exposure to absolute maximum rating conditions for extended periods may affect device reliability.

TRUTH TABLE

CS#	OE#	WE#	Mode	Data I/O
H	X	X	Standby	High Z
L	L	H	Read	Data Out
L	H	L	Write	Data In
X	H	X	Out Disable	High Z/Data Out
X	X	H	Write	
X	L	X	Inhibit	

CAPACITANCE
 $T_A = +25^\circ\text{C}$

Parameter	Symbol	Conditions	Max	Unit
OE# capacitance	C_{OE}	$V_{IN} = 0\text{ V}, f = 1.0\text{ MHz}$	50	pF
WE1-4# capacitance HIP (PGA)	C_{WE}	$V_{IN} = 0\text{ V}, f = 1.0\text{ MHz}$	20	pF
CQFP G2T			20	
CS1-4# capacitance	C_{CS}	$V_{IN} = 0\text{ V}, f = 1.0\text{ MHz}$	20	pF
Data I/O capacitance	$C_{I/O}$	$V_{I/O} = 0\text{ V}, f = 1.0\text{ MHz}$	20	pF
Address input capacitance	C_{AD}	$V_{IN} = 0\text{ V}, f = 1.0\text{ MHz}$	50	pF

This parameter is guaranteed by design but not tested.

RECOMMENDED OPERATING CONDITIONS

Parameter	Symbol	Min	Max	Unit
Supply Voltage	V_{CC}	4.5	5.5	V
Input High Voltage	V_{IH}	2.0	$V_{CC} + 0.3$	V
Input Low Voltage	V_{IL}	-0.5	+0.8	V
Operating Temp. (Mil.)	T_A	-55	+125	°C
Operating Temp. (Ind.)	T_A	-40	+85	°C

DC CHARACTERISTICS
 $V_{CC} = 5.0\text{ V}, \text{GND} = 0\text{ V}, -55^\circ\text{C} \leq T_A \leq +125^\circ\text{C}$

Parameter	Symbol	Conditions	Min	Max	Unit
Input Leakage Current	I_{LI}	$V_{CC} = 5.5, V_{IN} = \text{GND to } V_{CC}$		10	μA
Output Leakage Current	I_{LOx32}	$\text{CS\#} = V_{IH}, \text{OE\#} = V_{IH}, V_{OUT} = \text{GND to } V_{CC}$		10	μA
Operating Supply Current (x32)	I_{CCx32}	$\text{CS\#} = V_{IL}, \text{OE\#} = V_{IH}, f = 5\text{ MHz}$		250	mA
Standby Current	I_{SB}	$\text{CS\#} = V_{IH}, \text{OE\#} = V_{IH}, f = 5\text{ MHz}$		2.5	mA
Output Low Voltage	V_{OL}	$I_{OL} = 2.1\text{ mA}, V_{CC} = 4.5\text{ V}$		0.45	V
Output High Voltage	V_{OH}	$I_{OH} = -400\mu\text{A}, V_{CC} = 4.5\text{ V}$	2.4		V

NOTE: DC test conditions: $V_{IH} = V_{CC} - 0.3\text{ V}, V_{IL} = 0.3\text{ V}$

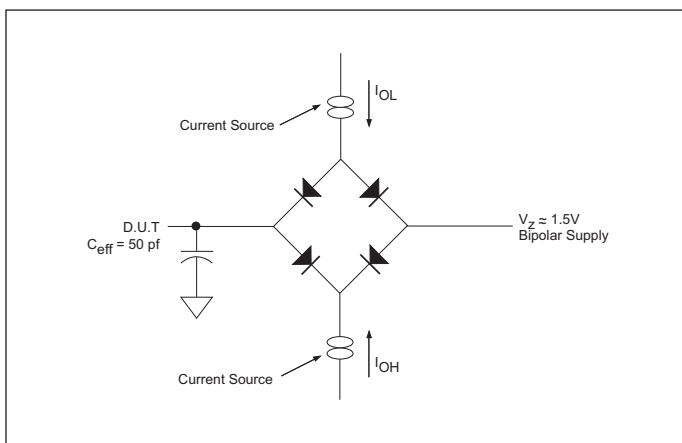
FIGURE 3 AC TEST CIRCUIT

AC TEST CONDITIONS

Parameter	Typ	Unit
Input Pulse Levels	$V_{IL} = 0, V_{IH} = 3.0$	V
Input Rise and Fall	5	ns
Input and Output Reference Level	1.5	V
Output Timing Reference Level	1.5	V

Notes: V_z is programmable from -2V to +7V.

I_{OL} & I_{OH} programmable from 0 to 16mA.

Tester Impedance $Z_0 = 75\Omega$.

V_z is typically the midpoint of V_{OH} and V_{OL} .

I_{OL} & I_{OH} are adjusted to simulate a typical resistive load circuit.

ATE tester includes jig capacitance.

WRITE

A write cycle is initiated when OE# is high and a low pulse is on WE# or CS# with CS# or WE# low. The address is latched on the falling edge of CS# or WE# whichever occurs last. The data is latched by the rising edge of CS# or WE#, whichever occurs first. A byte write operation will automatically continue to completion.

WRITE CYCLE TIMING

Figures 5 and 6 show the write cycle timing relationships. A write cycle begins with address application, write enable and chip select. Chip select is accomplished by placing the CS# line low. Write enable consists of setting the WE# line low. The write cycle begins when the last of either CS# or WE# goes low.

The WE# line transition from high to low also initiates an internal 150 μ sec delay timer to permit page mode operation. Each subsequent WE# transition from high to low that occurs before the completion of the 150 μ sec time out will restart the timer from zero. The operation of the timer is the same as a retriggerable one-shot.

AC WRITE CHARACTERISTICS

$V_{CC} = 5.0V, GND = 0V, -55^{\circ}C \leq T_A \leq +125^{\circ}C$

Write Cycle Parameter	Symbol	Min	Max	Unit
Write Cycle Time, TYP = 6ms	t_{WC}		10	ms
Address Set-up Time	t_{AS}	0		ns
Write Pulse Width (WE# or CS#)	t_{WP}	100		ns
Chip Select Set-up Time	t_{CS}	0		ns
Address Hold Time	t_{AH}	100		ns
Data Hold Time	t_{DH}	10		ns
Chip Select Hold Time	t_{CSH}	0		ns
Data Set-up Time	t_{DS}	50		ns
Output Enable Set-up Time	t_{OES}	0		ns
Output Enable Hold Time	t_{OEH}	0		ns
Write Pulse Width High	t_{WPH}	50		ns

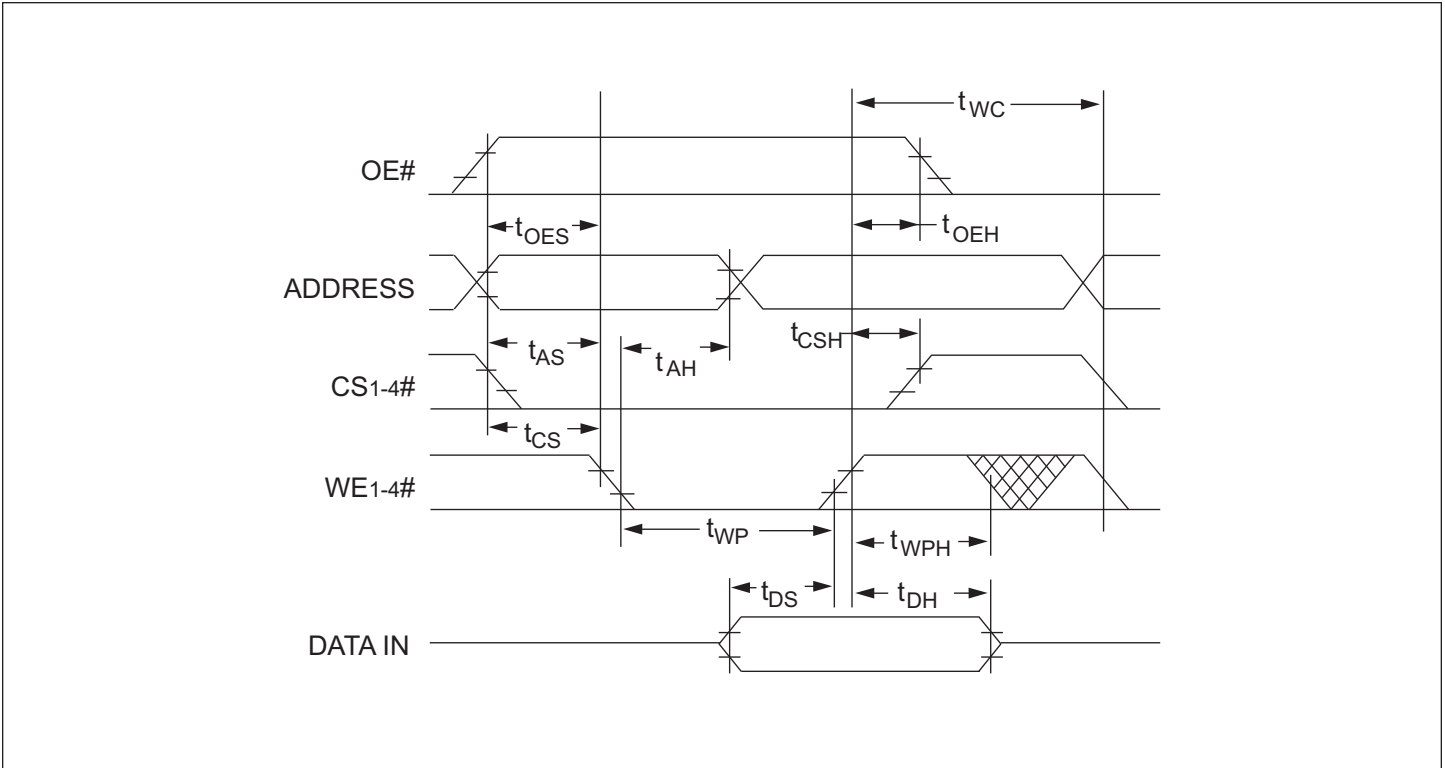
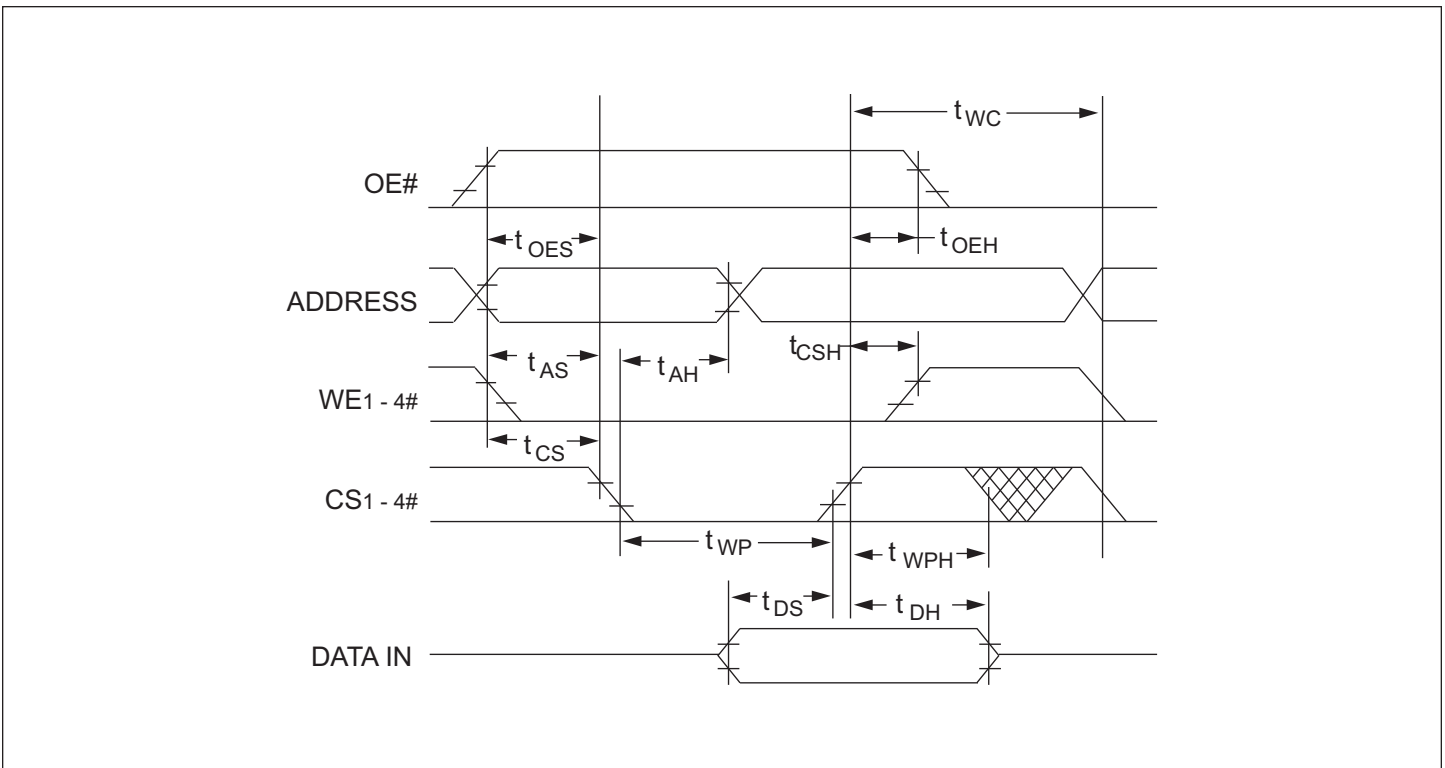
FIGURE 5 – WRITE WAVEFORMS WE# CONTROLLED

FIGURE 6 – WRITE WAVEFORMS CS# CONTROLLED

READ

The WE128K32-XXX stores data at the memory location determined by the address pins. When CS# and OE# are low and WE# is high, this data is present on the outputs. When CS# and OE# are high, the outputs are in a high impedance state. This two line control prevents bus contention.

AC READ CHARACTERISTICS

$V_{CC} = 5.0V, GND = 0V, -55^{\circ}C \leq T_A \leq +125^{\circ}C^*$

Read Cycle Parameter	Symbol	-125		-140		-150		-200		-250		-300		Unit
		Min	Max	Min	Max	Min	Max	Min	Max	Min	Max	Min	Max	
Read Cycle Time	t_{RC}	125		140		150		200		250		300		ns
Address Access Time	t_{ACC}		125		140		150		200		250		300	ns
Chip Select Access Time	t_{ACS}		125		140		150		200		250		300	ns
Output Hold from Add. Change, OE# or CS#	t_{OH}	0		0		0		0		0		0		ns
Output Enable to Output Valid	t_{OE}	0	50	0	55	0	55	0	55	0	85	0	85	ns
Chip Select or OE# to High Z Output	t_{DF}		60		70		70		70		70		70	ns

FIGURE 7 – READ WAVEFORMS

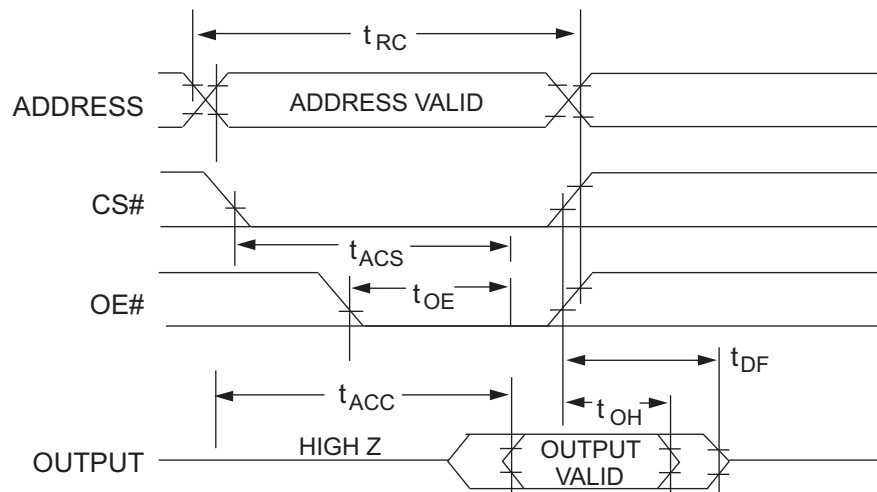

Notes:

OE# may be delayed up to $t_{ACS} - t_{OE}$ after the falling edge of CS# without impact on t_{OE} or by $t_{ACC} - t_{OE}$ after an address change without impact on t_{ACC} .

DATA POLLING

The WE128K32-XXX offers a data polling feature which allows a faster method of writing to the device. Figure 8 shows the timing diagram for this function. During a byte or page write cycle, an attempted read of the last byte written will result in the complement of the written data on D7 (for each chip.) Once the write cycle has been completed, true data is valid on all outputs and the next cycle may begin. Data polling may begin at any time during the write cycle.

DATA POLLING CHARACTERISTICS

($V_{CC} = 5.0V$, $V_{SS} = 0V$, $T_A = -55^{\circ}C$ to $+125^{\circ}C$)

Parameter	Symbol	Min	Max	Unit
Data Hold Time	t_{DH}	10		ns
OE# Hold Time	$t_{OE\#}$	10		ns
OE# To Output Valid	t_{OE}		55	ns
Write Recovery Time	t_{WR}	0		ns

FIGURE 8 – DATA POLLING WAVEFORMS

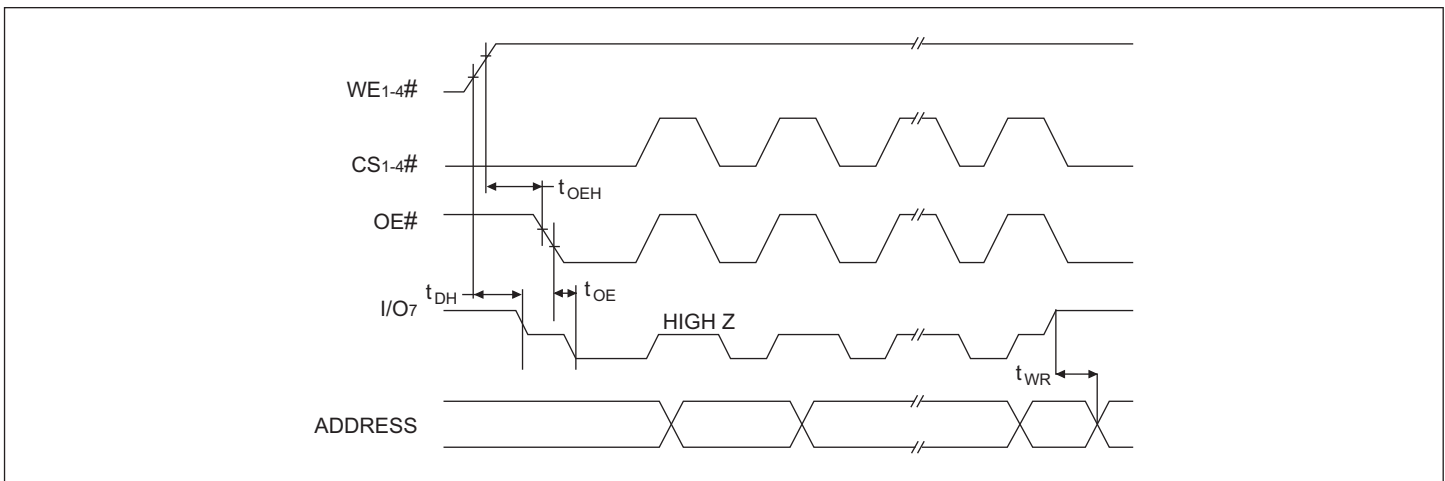

TOGGLE BIT: In addition to DATA# Polling another method for determining the end of a write cycle is provided. During the write operation, successive attempts to read data from the device will result in I/O6 toggling between one and zero. Once the write has completed, I/O6 will stop toggling and valid data will be read. Reading the toggle bit may begin at any time during the write cycle.

TOGGLE BIT CHARACTERISTICS⁽¹⁾

Symbol	Parameter	Min	Max	Units
t_{DH}	Data Hold Time	10		ns
$t_{OE\#}$	OE# Hold Time	10		ns
t_{OE}	OE# to Output Delay			ns
t_{OEHP}	OE# High Pulse	150		ns
t_{WR}	Write Recovery Time	0		ns

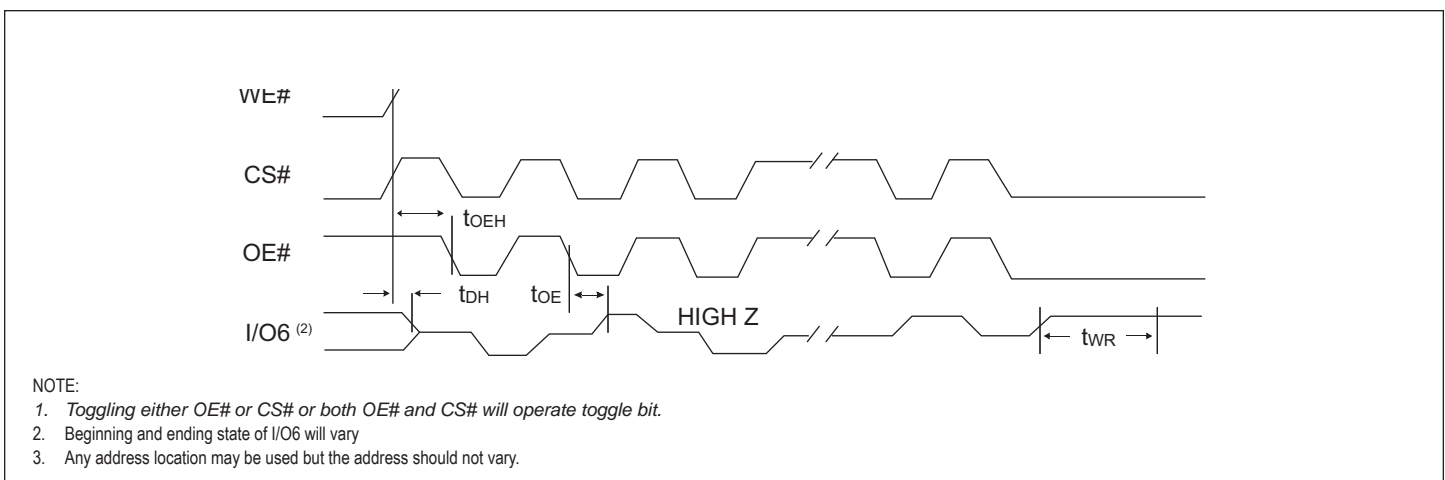

PAGE WRITE OPERATION

The WE128K32-XXX has a page write operation that allows one to 128 bytes of data to be written into the device and consecutively loads during the internal programming period. Successive bytes may be loaded in the same manner after the first data byte has been loaded. An internal timer begins a time out operation at each write cycle. If another write cycle is completed within 150 μ s or less, a new time out period begins. Each write cycle restarts the delay period. The write cycles can be continued as long as the interval is less than the time out period.

The usual procedure is to increment the least significant address lines from A0 through A6 at each write cycle. In this manner a page of up to 128 bytes can be loaded in to the EEPROM in a burst mode before beginning the relatively long interval programming cycle.

After the 150 μ s time out is completed, the EEPROM begins an internal write cycle. During this cycle the entire page of bytes will be written at the same time. The internal programming cycle is the same regardless of the number of bytes accessed.

PAGE WRITE CHARACTERISTICS

($V_{CC} = 5.0V$, $V_{SS} = 0V$, $T_A = -55^{\circ}C$ to $+125^{\circ}C$)

Page Mode Write Characteristics				
Parameter	Symbol	Min	Max	Unit
Write Cycle Time, TYP = 6ms	t_{WC}		10	ms
Address Set-up Time	t_{AS}	0		ns
Address Hold Time (1)	t_{AH}	100		ns
Data Set-up Time	t_{DS}	50		ns
Data Hold Time	t_{DH}	10		ns
Write Pulse Width	t_{WP}	100		ns
Byte Load Cycle Time	t_{BLC}		150	μ s
Write Pulse Width High	t_{WPH}	50		ns

1. Page address must remain valid for duration of write cycle.

FIGURE 9 – PAGE MODE WRITE WAVEFORMS

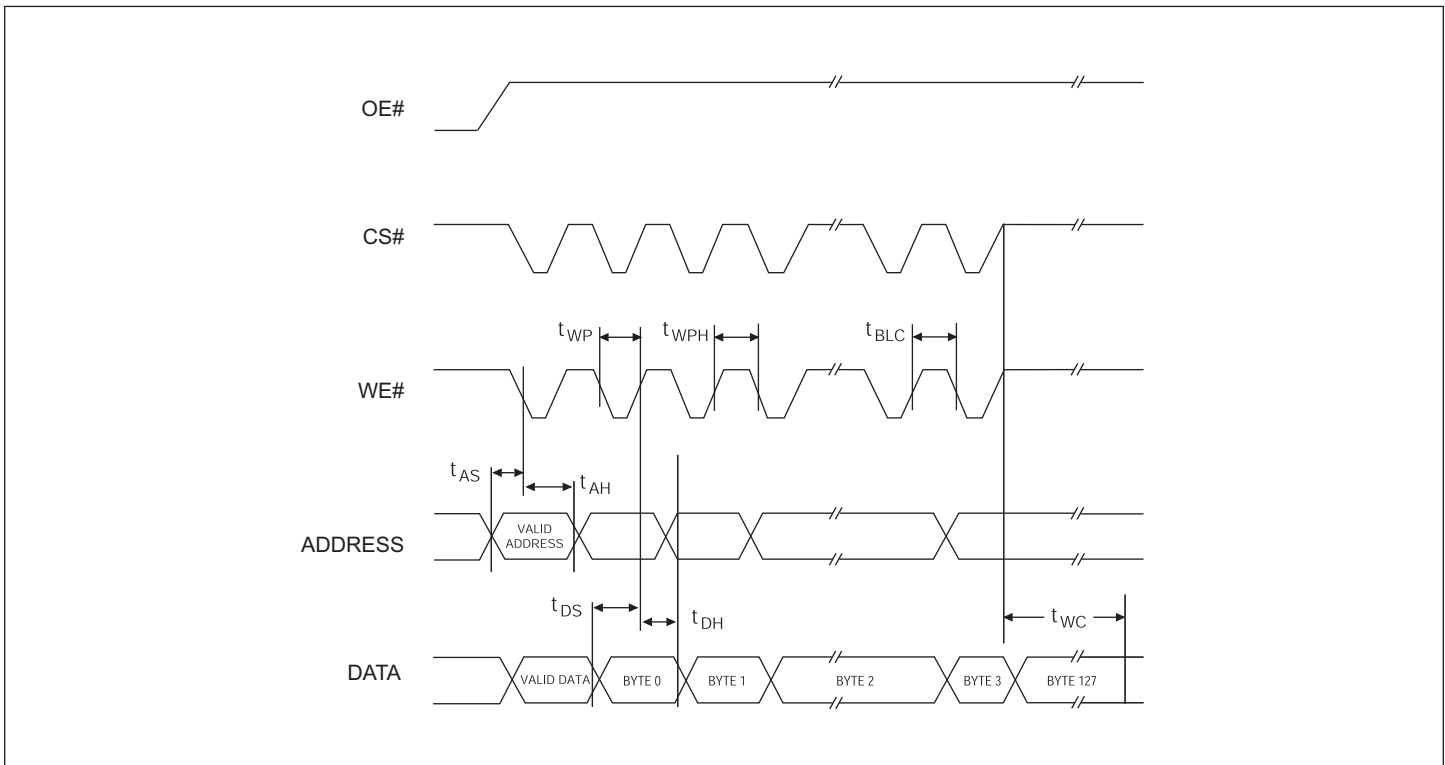
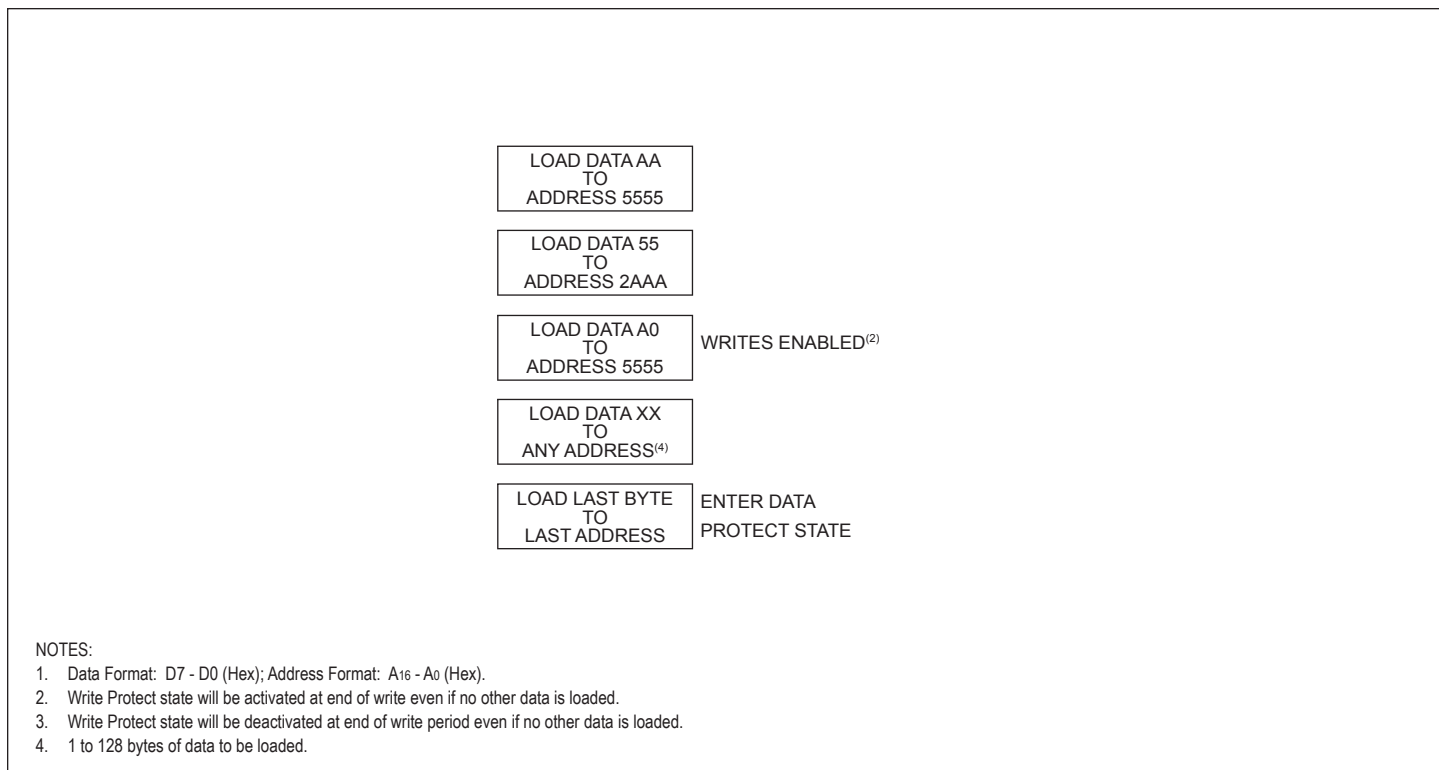
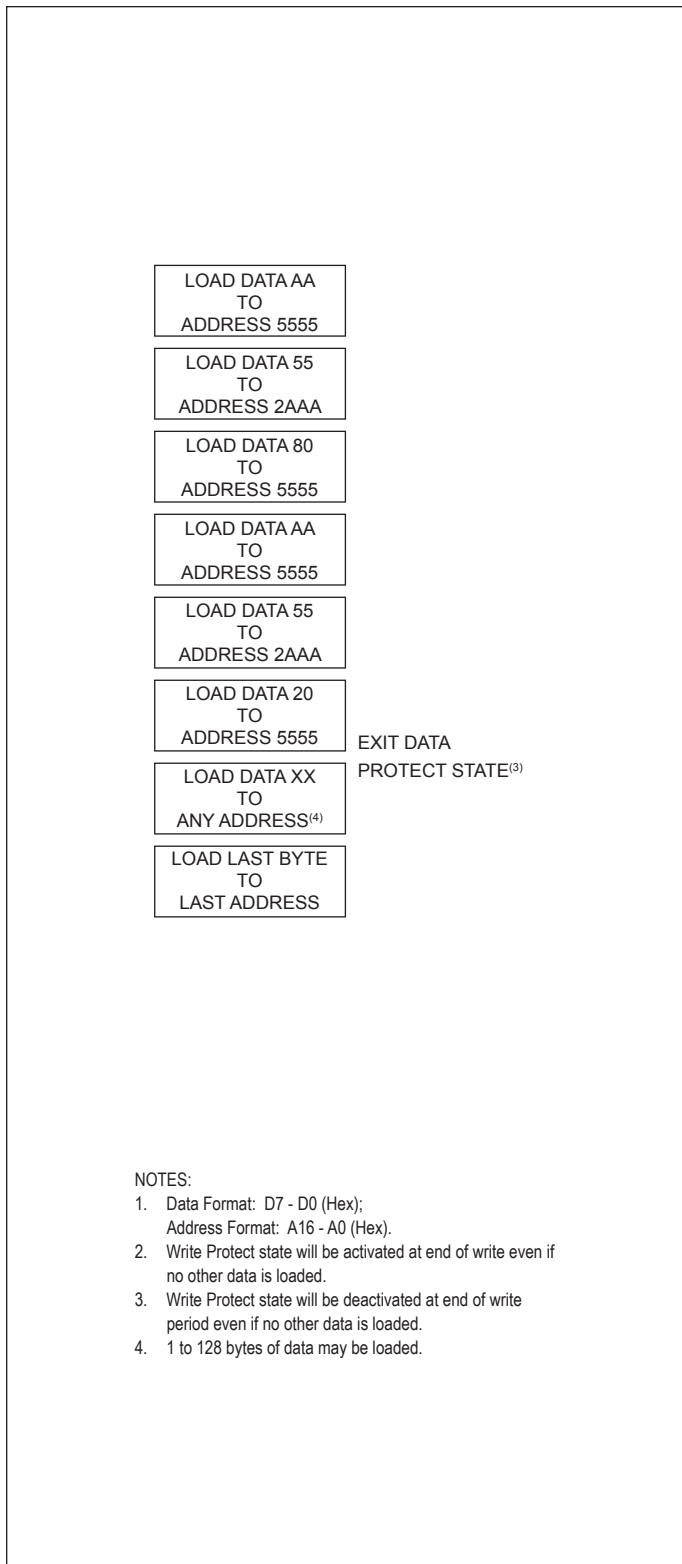

FIGURE 10 – SOFTWARE BLOCK DATA PROTECTION ENABLE ALGORITHM⁽¹⁾

**FIGURE 10 –
SOFTWARE BLOCK DATA PROTECTION DISABLE
ALGORITHM⁽¹⁾**



SOFTWARE DATA PROTECTION

A software write protection feature may be enabled or disabled by the user. When shipped by White Microelectronics, the WE-128K32-XXX has the feature disabled. Write access to the device is unrestricted.

To enable software write protection, the user writes three access code bytes to three special internal locations. Once write protection has been enabled, each write to the EEPROM must use the same three byte write sequence to permit writing. After setting software data protection, any attempt to write to the device without the three-byte command sequence will start the internal write timers. No data will be written to the device, however, for the duration of *t_{wc}*. The write protection feature can be disabled by a six byte write sequence of specific data to specific locations. Power transitions will not reset the software write protection.

Each 128K byte block of the EEPROM has independent write protection. One or more blocks may be enabled and the rest disabled in any combination. The software write protection guards against inadvertent writes during power transitions, or unauthorized modification using a PROM programmer.

HARDWARE DATA PROTECTION

These features protect against inadvertent writes to the WE128K32-XXX. These are included to improve reliability during normal operation:

- V_{cc} power on delay**
As V_{cc} climbs past 3.8V typical the device will wait 5msec typical before allowing write cycles.
- V_{cc} sense**
While below 3.8V typical write cycles are inhibited.
- Write inhibiting**
Holding OE# low and either CS# or WE# high inhibits write cycles.
- Noise filter**
Pulses of <8ns (typ) on WE# or CS# will not initiate a write cycle.

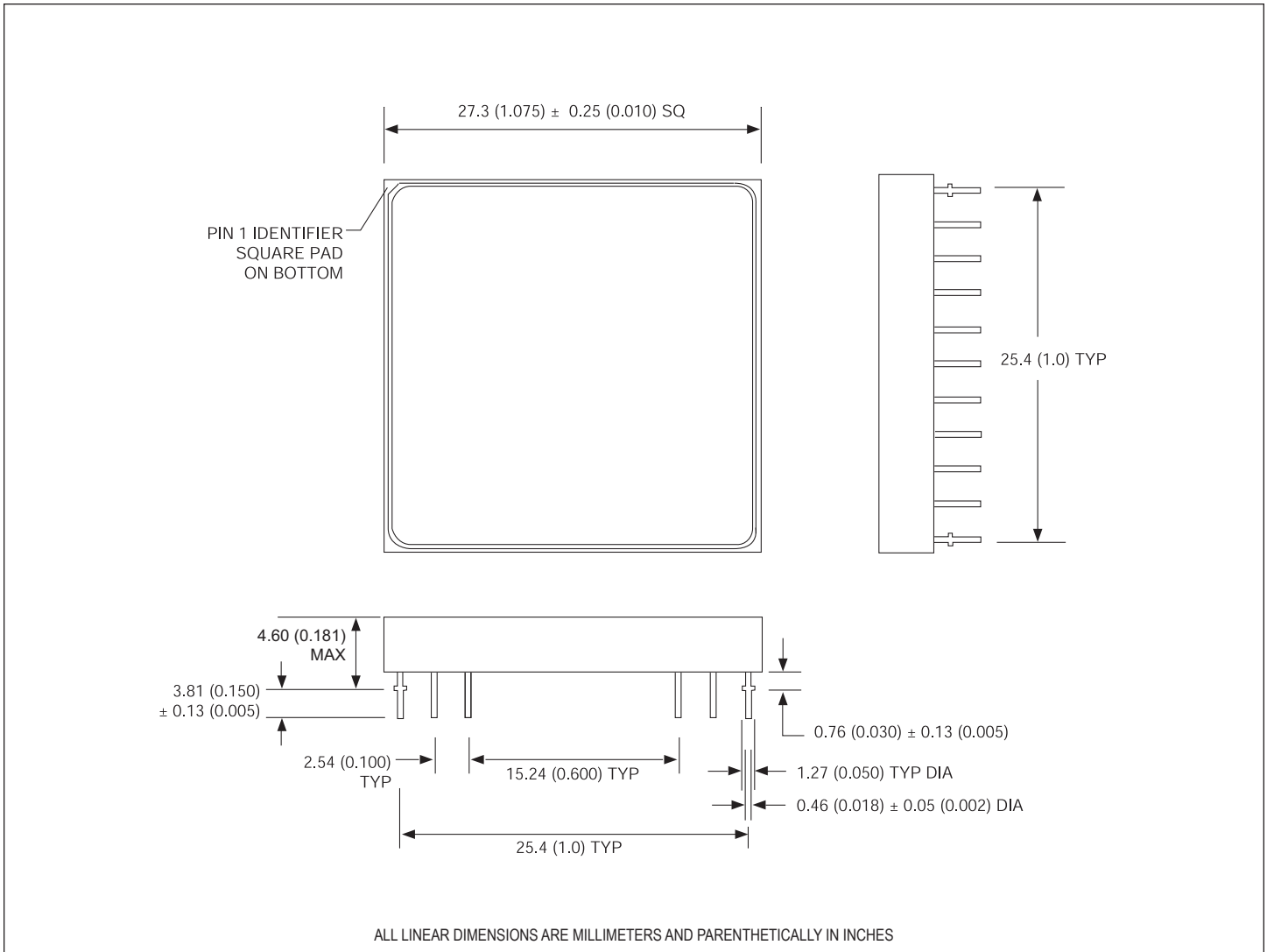
PACKAGE 400 – 66 PIN, PGA TYPE, CERAMIC HEX-IN-LINE PACKAGE, HIP (H1)

PACKAGE 509 – 68 LEAD, CERAMIC QUAD FLAT PACK, CQFP (G2T)

FIGURE 12 – ALTERNATE PIN CONFIGURATION FOR WE128K32NP-XH1X



ORDERING INFORMATION

W E 128K32 X - XXX X X X

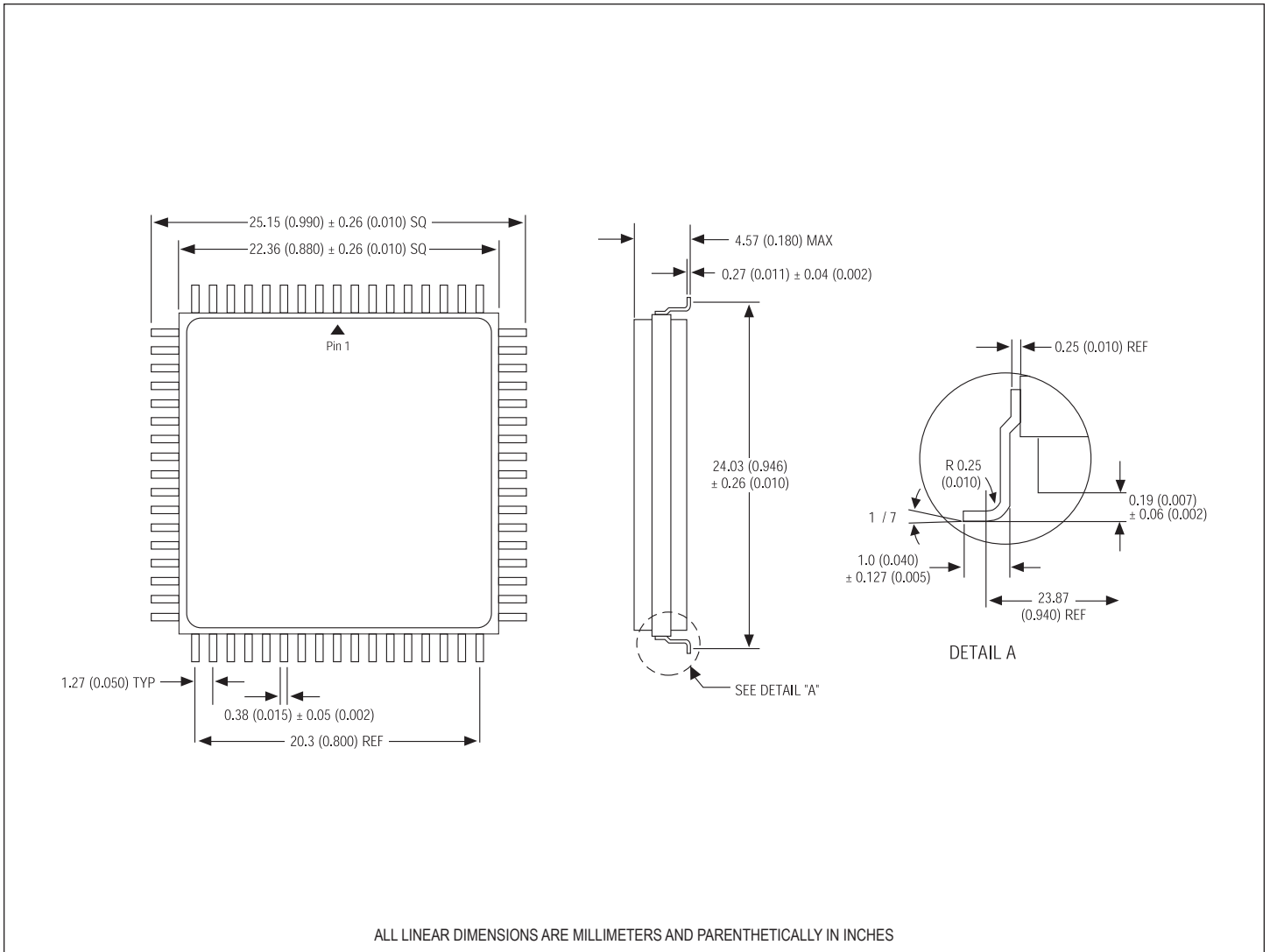
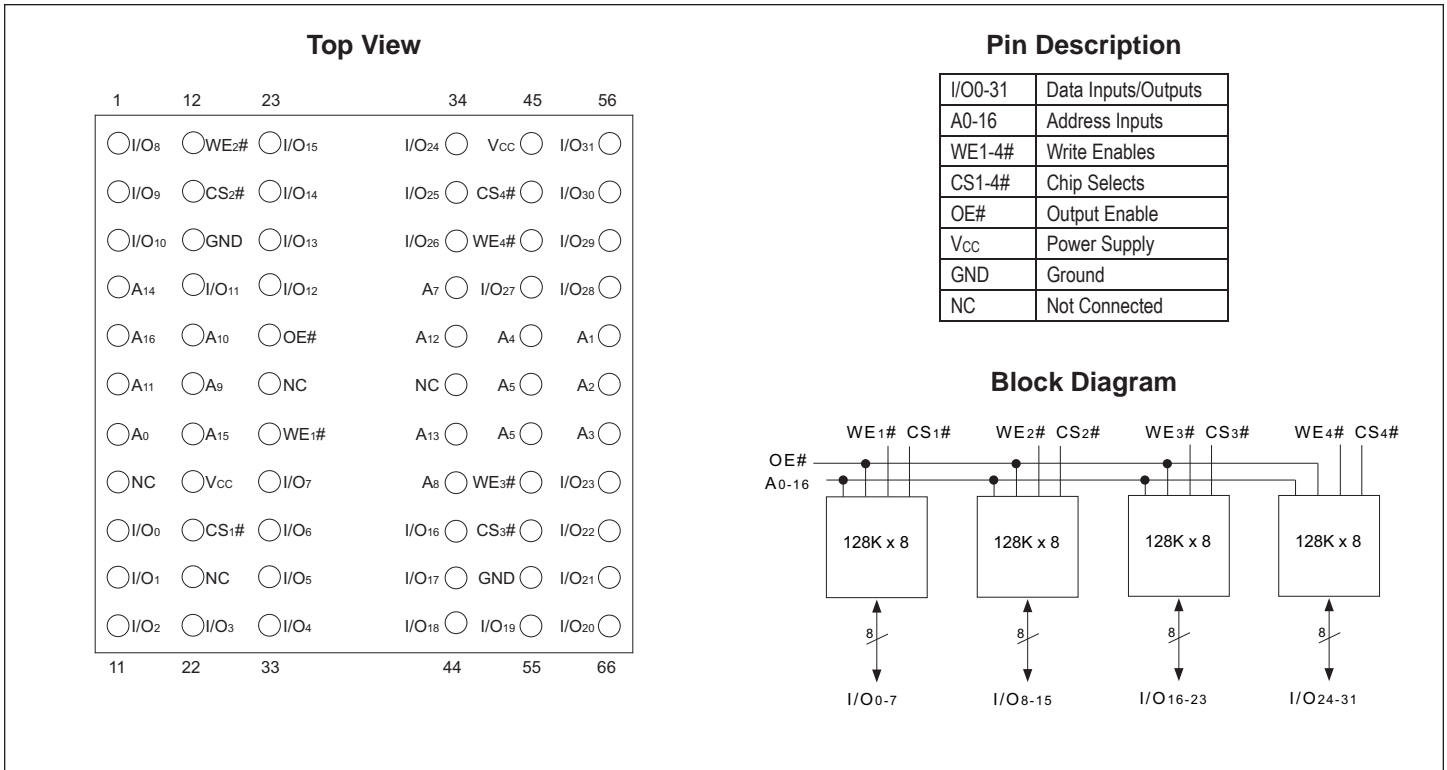
MICROSEMI CORPORATION _____

EEPROM _____

Organization 128K x 32 _____

User Configurable as 256K x 16 or 512K x 8

IMPROVEMENT MARK _____

N = No Connect at pins 8, 21, 28, and 39 in HIP for upgrade

P = Alternate Pin Configuration for HIP package

ACCESS TIME (ns)* _____

PACKAGE TYPE: _____

H1 = 1.075" sq. Ceramic Hex In-line Package, HIP (Package 400*)

G2T = 22.4mm Ceramic Quad Flat Pack, Low Profile CQFP (Package 509)

DEVICE GRADE: _____

Q = Military Grade**

M = Military Screened -55°C to +125°C

I = Industrial -40°C to +85°C

C = Commercial 0°C to +70°C

LEAD FINISH: _____

Blank = Gold plated leads

A = Solder dip leads

* 120 available in commercial and industrial temperature only.

** This product is processed the same as the 5962-XXXXXHX product but all test and mechanical requirements are per the Microsemi data sheet.

DEVICE TYPE	SPEED	PACKAGE	SMD NO.
128K x 32 EEPROM Module	300ns	66 pin HIP (H1)	5962-94585 01H5X
128K x 32 EEPROM Module	250ns	66 pin HIP (H1)	5962-94585 02H5X
128K x 32 EEPROM Module	200ns	66 pin HIP (H1)	5962-94585 03H5X
128K x 32 EEPROM Module	150ns	66 pin HIP (H1)	5962-94585 04H5X
128K x 32 EEPROM Module	140ns	66 pin HIP (H1)	5962-94585 05H5X
128K x 32 EEPROM Module	300ns	66 pin HIP (H1, P type pinout)	5962-94585 01H6X
128K x 32 EEPROM Module	250ns	66 pin HIP (H1, P type pinout)	5962-94585 02H6X
128K x 32 EEPROM Module	200ns	66 pin HIP (H1, P type pinout)	5962-94585 03H6X
128K x 32 EEPROM Module	150ns	66 pin HIP (H1, P type pinout)	5962-94585 04H6X
128K x 32 EEPROM Module	140ns	66 pin HIP (H1, P type pinout)	5962-94585 05H6X
128K x 32 EEPROM Module	300ns	68 lead CQFP/J (G2T)	5962-94585 01HMX
128K x 32 EEPROM Module	250ns	68 lead CQFP/J (G2T)	5962-94585 02HMX
128K x 32 EEPROM Module	200ns	68 lead CQFP/J (G2T)	5962-94585 03HMX
128K x 32 EEPROM Module	150ns	68 lead CQFP/J (G2T)	5962-94585 04HMX
128K x 32 EEPROM Module	140ns	68 lead CQFP/J (G2T)	5962-94585 05HMX
128K x 32 EEPROM Module	300ns	66 pin HIP (H1) (no connect)	5962-94585 01H4X
128K x 32 EEPROM Module	250ns	66 pin HIP (H1) (no connect)	5962-94585 02H4X
128K x 32 EEPROM Module	200ns	66 pin HIP (H1) (no connect)	5962-94585 03H4X
128K x 32 EEPROM Module	150ns	66 pin HIP (H1) (no connect)	5962-94585 04H4X
128K x 32 EEPROM Module	140ns	66 pin HIP (H1) (no connect)	5962-94585 05H4X

Document Title

128Kx32 EEPROM MODULE, SMD 5962-94585

Revision History

Rev #	History	Release Date	Status
Rev 14	Changes (Pg. 1-16) 14.1 Change document layout from White Electronic Designs to Microsemi 14.2 Add document Revision History page	August 2011	Final
Rev 15	Changes (Pg. 15) 15 Add (H1) (no connect) 01H4X, 02H4X, 03H4X, 04H4X, 05H4X to SDM NO. part list.	April 2012	Final
Rev 16	Change (Pg. 15) 16.1 Changed Device Grade "Q" description from "Compliant" to "MIL-PRF-38534 Class H Compliant."	May 2014	Final
Rev 17	Change (Pg. 15) 17.1 Changed Device Grade "Q" description from "MIL-PRF-38534 Class H Compliant" to "Military Grade."	August 2014	Final