

L1TSM-PL



SMA Male Positive Lock for 1/4 in LDF1-50 cable

Product Classification

Product Type	Wireless and radiating connector
Product Brand	HELIAX®

General Specifications

Body Style	Straight
Cable Family	LDF1-50
Inner Contact Attachment Method	Captivated
Inner Contact Plating	Gold
Interface	SMA Male
Mounting Angle	Straight
Outer Contact Attachment Method	Self-flare
Outer Contact Plating	Trimetal
Pressurizable	No

Dimensions

Height	16 mm 0.63 in
Width	16 mm 0.63 in
Length	40.64 mm 1.6 in
Diameter	16 mm 0.63 in
Nominal Size	1/4 in

Outline Drawing

L1TSM-PL

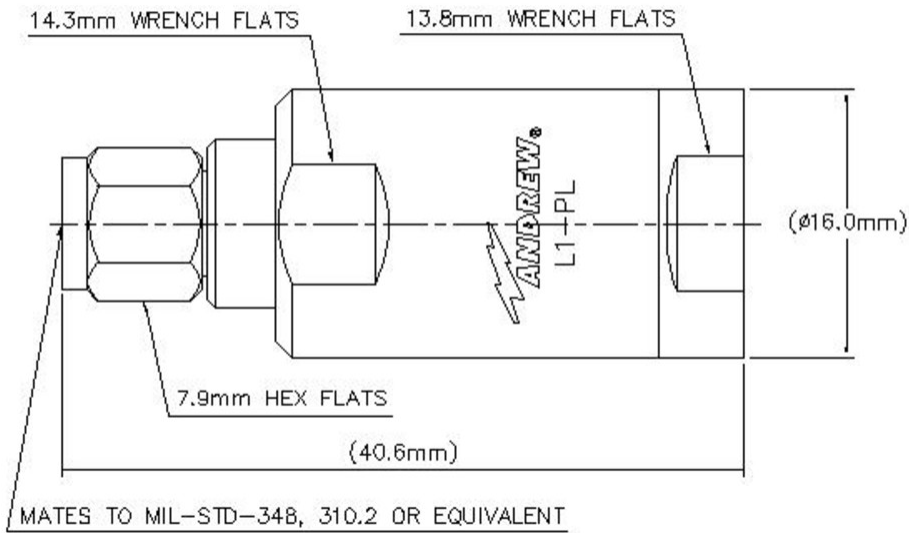

Electrical Specifications

Insertion Loss, typical	0.05 dB
Average Power at Frequency	0.6 kW @ 900 MHz
Cable Impedance	50 ohm
Connector Impedance	50 ohm
dc Test Voltage	1000 V
Inner Contact Resistance, maximum	3 mOhm
Insulation Resistance, minimum	5000 MOhm
Operating Frequency Band	0 – 13500 MHz
Outer Contact Resistance, maximum	2.5 mOhm
Peak Power, maximum	5 kW
RF Operating Voltage, maximum (vrms)	500 V
Shielding Effectiveness	-110 dB

VSWR/Return Loss

Frequency Band	VSWR	Return Loss (dB)
0–960 MHz	1.03	40
960–2200 MHz	1.03	37
2200–2700 MHz	1.03	37

LITSM-PL

2700–4000 MHz	1.05	33
4000–6000 MHz	1.12	25.6
6000–8000 MHz	1.16	23
8000–10000 MHz	1.22	20.4
10000–12000 MHz	1.28	18.4
12000–13500 MHz	1.41	15.4

Mechanical Specifications

Attachment Durability	25 cycles
Connector Retention Tensile Force	449.27 N 101 lbf
Coupling Nut Proof Torque	1.7 N-m 15.046 in lb
Coupling Nut Retention Force	266.98 N 60.02 lbf
Coupling Nut Retention Force Method	MIL-C-39012C-3.25, 4.6.22
Insertion Force	22.02 N 4.95 lbf
Insertion Force Method	IEC 61169-1:15.2.4
Interface Durability	500 cycles
Interface Durability Method	IEC 61169-15:9.5
Mechanical Shock Test Method	IEC 60068-2-27

Environmental Specifications

Operating Temperature	-55 °C to +85 °C (-67 °F to +185 °F)
Storage Temperature	-65 °C to +125 °C (-85 °F to +257 °F)
Attenuation, Ambient Temperature	20 °C 68 °F
Average Power, Ambient Temperature	40 °C 104 °F
Average Power, Inner Conductor Temperature	100 °C 212 °F
Corrosion Test Method	IEC 60068-2-11
Immersion Depth	1 m
Immersion Test Mating	Mated
Immersion Test Method	IEC 60529:2001, IP68
Moisture Resistance Test Method	IEC 60068-2-3
Thermal Shock Test Method	IEC 60068-2-14
Vibration Test Method	IEC 60068-2-6

L1TSM-PL

Packaging and Weights

Weight, net

34.16 g | 0.075 lb

Regulatory Compliance/Certifications

Agency

CHINA-ROHS

ISO 9001:2015

ROHS

Classification

Below maximum concentration value

Designed, manufactured and/or distributed under this quality management system

Compliant



* Footnotes

Insertion Loss, typical 0.05v̄freq (GHz) (not applicable for elliptical waveguide)

Immersion Depth Immersion at specified depth for 24 hours