



Integrated Low Profile Transceiver Module for Telecom Applications – IrDA Standard



Description

The TFDU4102 and TFDS4402 are ideal transceivers for applications in telecommunications like mobile phones and pagers. The device is mechanically designed for low profile applications covering the full IrDA range of one meter. The infrared transceiver is compatible to the IrDA® IrPHY specification version 1.3 up to a data rate of 115.2 kbit/s. At lower operating voltages up to 3.3 V the transceiver can be operated without external current limiting resistor to achieve full SIR compliance (range > 1 m in full 15° cone).

Vishay Semiconductors TFDS4402 transceiver represents a novel package option with the same chipset as TFDU4202 enabling a minimized package height over the PCB of only 1.8 mm and nevertheless offering a full 1 m transmission range. The output intensity is adjustable by an external resistor to save current consumption in low power applications. TFDU4102 uses the same chipset in the well known babyface package. For operating only in the distance limited low power range (20 cm/ 30 cm) another device of this family, TFDU4201, with reduced IRED drive current is recommended.

Features

- Two More Surface Mount Package Options
 - Babyface Universal **TFDU4102**: (9.7 × 4.7 × 4.0 mm³)
 - For In-board Hidden Mounting: Side View Dracula **TFDS4402**
- Compatible to IrDA IrPHY 1.3 Standard
- SMD Side View
- Lowest Power Consumption
55 μA Receive Mode, 0.01 μA Shutdown
- Built-in Current Limitation
- Output Intensity Adjustable by External Resistor
- Wide Supply Voltage Range (2.4 V to 5.5 V)
- Split Power Supply
- Operational down to 2.0 V
- Fewest External Components
- Eye Safety: Double Safety Measures:
Limited Optical Output Pulse Duration
Limited Optical Output Intensity
- Tri-State Output (Rxd)
- High EMI Immunity

Applications

Mobile Phones, Pagers, Personal Digital Assistants (PDA), Handheld Battery Operated Equipment

Package Options

TFDU4102
Baby Face (Universal
weight 0.20 g

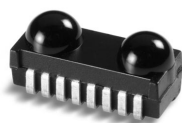

TFDS4402
Dracula
weight 0.20 g

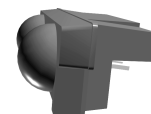

TFDU4102/TFDS4402 Selector Guide

	Rxd Output in Txd Mode	IRED Drive Capability	IrDA Compliance	Power Supply
TFDU4102 TFDS4402	Quiet**) necessary for some WinCE® applications	Internally current controlled to cover full IrDA range. Current level can be reduced by an external resistor	Low Power SIR as e.g. TFDU4201 or up to full IrDA SIR distance > 1m	Split power supply*) can be used when operated at higher IRED current levels

- *) Split power supply: The receiver circuit only is connected to a regulated power supply. The high IRED current can be supplied by a less controlled power line or directly from the battery. That feature saves power supply costs. Vishay introduced this feature as the world first with the 4000-series.
- **) Depending on the designs different applications need an optical feedback for test purposes or must be quiet (e.g. in Windows CE® applications)

Ordering Information

Part Number	Qty / Reel	Description
TFDU4102-TR3	1000	Babyface, Oriented in carrier tape for side view in mounting
TFDU4102-TT3	1000	Babyface, Oriented in carrier tape for top view in mounting
TFDS4402-TR3	1000	Dracula, Oriented in carrier tape for side view in mounting

Functional Block Diagram

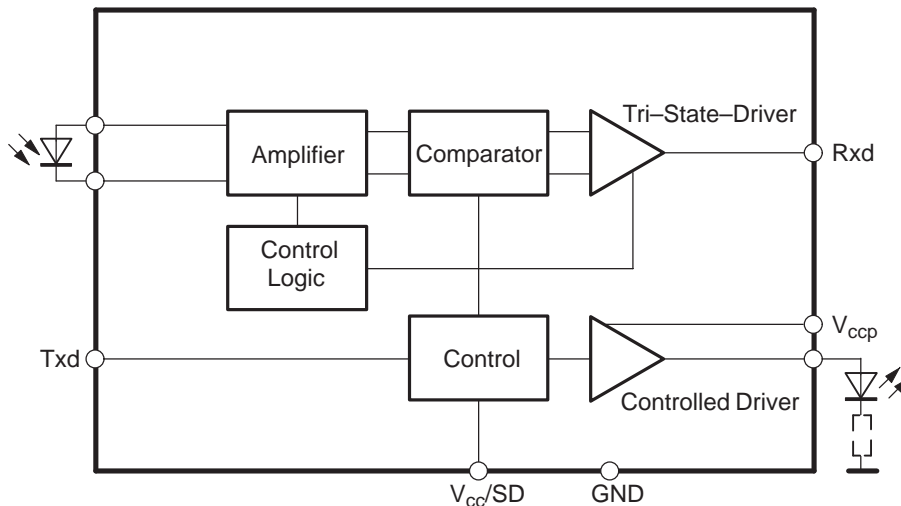

Figure 1. Functional Block Diagram

Pin Description TFDU4102/TFDS4402

Pin	Symbol	Description	I/O	Active
1	NC	Not connected		
2	IRED GND	IRED Cathode Ground		
3	Rxd	Output, Received Data, Tri-state, Floating in Shutdown Mode ($V_{CC}/SD = Low$)	O	LOW
4	V_{CC}	Supply Voltage		
5	V_{CCP}	Supply Voltage IRED Driver		
6	SD	Shutdown		
7	Txd	Input, Transmit Data	I	HIGH
8	GND	Ground	I	HIGH

**Absolute Maximum Ratings**

Reference Point Pin 8, unless otherwise noted.

Parameter	Test Conditions	Symbol	Min.	Typ.	Max.	Unit	Remarks
Supply Voltage Range		V_{CC}	-0.5		6	V	
		V_{CCP}	-0.5		6	V	
Input Current					10	mA	All Input Pins
Output Sink Current					25	mA	
Power Dissipation		P_{tot}			200	mW	
Junction Temperature		T_J			125	°C	
Ambient Temperature Range (Operating)		T_{amb}	-25		85	°C	
Storage Temperature Range		T_{stg}	-40		85	°C	
Soldering Temperature	t = 20 s @215°C			215	240	°C	See Vishay IrDA Design Guide
Average IRED Current		$I_{IRED(DC)}$			125	mA	
Repetitive Pulsed IRED Current		$I_{IRED(RP)}$			500	mA	<90 μ s, t_{on} <20%
Transmitter Data Input Voltage		V_{Txd}	-0.5		$V_{CC}+0.5$	V	
Receiver Data Output Voltage		V_{Rxd}	-0.5		$V_{CC}+0.5$	V	
Virtual source size (TFDS4402/TFDU4102 only)	Method: (1-1/e) encircled energy	d		3		mm	
Compatible to Class 1 operation of IEC 60825 or EN60825 with worst case IrDA SIR pulse pattern, 115.2 kbit/s							

Electrical Characteristics

Tested for the following parameters ($V_{CC} = 2.4\text{ V}$ to 5.5 V , 25°C , unless otherwise stated)

Parameter	Test Conditions	Symbol	Min.	Typ.	Max.	Unit	Remarks
Transceiver							
Supported Data Rates	Base band		9.6		115.2	kbit/s	
Supply Voltage Range		V_{CC}	2.4		5.5	V	Operational Down to 2.0 V
Supply Current	$V_{CC} = 2.4\text{ V}$ to 5.5 V , $E_e = 0$	I_S		65	80	μA	Receive Mode, full Temperature Range
	$V_{CC} = 2.4\text{ V}$ to 5.5 V , 10 klx Sunlight	I_S		70	90	μA	Receive Mode, full Temperature Range, no signal
	$V_{CC} = V_{CCP} = 2.7\text{ V}$, 115.2 kbit/s transmission	I_S		70	80	μA	Transmit Mode, full Temperature Range, or Receive Mode, Nose to Nose operation
Supply Current, @ V_{CCP}	Shutdown Mode, $V_{CC} = 0\text{ V}$	$I_{S\text{shutdown}}$		0.02	1 10	μA nA	Entire Temperature Range Room Temperature 20°C
TFDU4102 and TFDS4402 only: IRED Peak Current Transmitting	$I_e = 60\text{ mW/sr}$ internal current limitation $V_{CCP} = 2.7\text{ V}$	I_{Str}			360	mA	SIR Standard
Transceiver "Power On" Settling Time					100	μs	Time from Switching on V_{CCP} to Established Specified Operation



Optoelectronic Characteristics

Tested for the following parameters ($V_{CC} = 2.4\text{ V to }5.5\text{ V}$, 25°C , unless otherwise stated)

Parameter	Test Conditions	Symbol	Min.	Typ	Max.	Unit	Remarks
Receiver							
Minimum Detection Threshold Irradiance TFDU4102 only	$ \alpha \leq \pm 15^\circ$ $V_{CC} = 2.4\text{ V to }5.5\text{ V}$ 2.0 V	$E_{e, \min}$		20	35	mW/m^2	
					40	mW/m^2	25°C tested
Maximum Detection Threshold Irradiance	$ \alpha \leq \pm 90^\circ$ $V_{CC} = 5\text{ V}$	$E_{e, \max}$	3300	5000		W/m^2	
	$ \alpha \leq \pm 90^\circ$ $V_{CC} = 3\text{ V}$	$E_{e, \max}$	8000	15000		W/m^2	
Logic Low Receiver Input Irradiance		$E_{e, \max, \text{low}}$			4	mW/m^2	
Output Voltage Rxd	Active	V_{OL}		0.5	0.8	V	$C = 15\text{ pF}$, $R = 2.2\text{ k}\Omega$
	Non Active	V_{OH}	$V_{CC} - 0.5$			V	$C = 15\text{ pF}$, $R = 2.2\text{ k}\Omega$
Output Current Rxd $V_{OL} < 0.8\text{ V}$					4	mA	
Rise Time @Load: $C = 15\text{ pF}$, $R = 2.2\text{ k}$		t_r	20		200	ns	
Fall Time @Load: $C = 15\text{ pF}$, $R = 2.2\text{ k}$		t_f	20		200	ns	
Rxd Signal Electrical Output Pulse Width	2.4 kbit/s, Input Pulse Width 1.41 μs to 3/16 of bit Duration	t_p	1.4		20	μs	
Rxd Signal Electrical Output Pulse Width	115.2 kbit/s, Input Pulse Width 1.41 μs to 3/16 of bit Duration	t_p	1.4		4.5	μs	
Output Delay Time (Rxd), Leading Edge Optical Input to Electrical Output	Output Level = $0.5 \cdot V_{CC}$ @ 40 mW/m^2	t_{dl}		1	2	μs	
Jitter, Leading Edge of Output Signal	Over a Period of 10 bit, 115.2 kbit/s	t_j			0.4	μs	
Output Delay Time (Rxd), Trailing Edge Optical Input to Electrical Output	Output Level = $0.5 \cdot V_{CC}$ 40 mW/m^2	t_{dt}			6.5	μs	
SD recovery Time					100	μs	
Latency		t_L			100	μs	

Optoelectronic Characteristics (continued)

Tested for the following parameters ($V_{CC} = 2.4\text{ V to }5.5\text{ V}$, 25°C , unless otherwise stated)

Parameter	Test Conditions	Symbol	Min.	Typ	Max.	Unit	Remarks
Transmitter							
Logic Low Transmitter Input Voltage		$V_{IL}(\text{Txd})$	0		0.8	V	
Logic High Transmitter Input Voltage		$V_{IH}(\text{Txd})$	2.4		V_{CC}	V	
Optical Output Radiant Intensity $ \alpha \leq \pm 15^\circ$	$I_{F1} = 320\text{ mA}$, Current internally controlled	I_e	45			mW/sr	Voltage Range 2.7 V to 5.5 V
Peak Emission Wavelength		λ_p	880		900	nm	
Spectral Emission Bandwidth				60		nm	
Optical Rise/Falltime	115.2 kHz Square Wave Signal (duty cycle 1:1)				200	ns	
Optical Output Pulse Duration	Input Pulse Duration 1.6 μs		1.5	1.6	1.7	μs	Voltage Range 2.7 V to 5.5 V
Output Radiant Intensity	Logic Low Level				0.04	$\mu\text{W/sr}$	
Overshoot, Optical					25	%	
Rising Edge Peak to Peak Jitter	Over a Period of 10 bits, Independent of Information Content	t_j			0.2	μs	

Recommended SMD Pad Layout

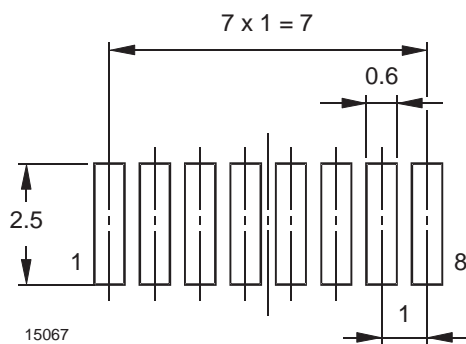

Figure 2. Pad Layout

Current Derating Diagram

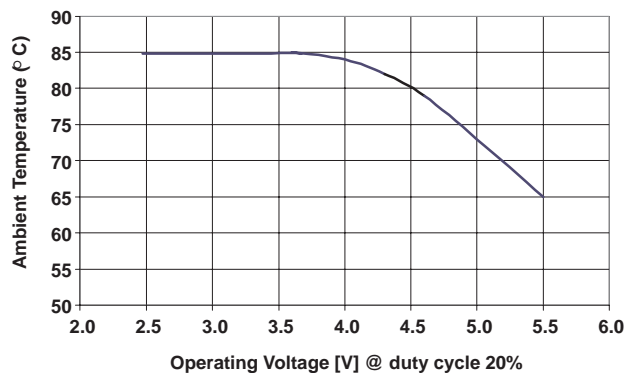
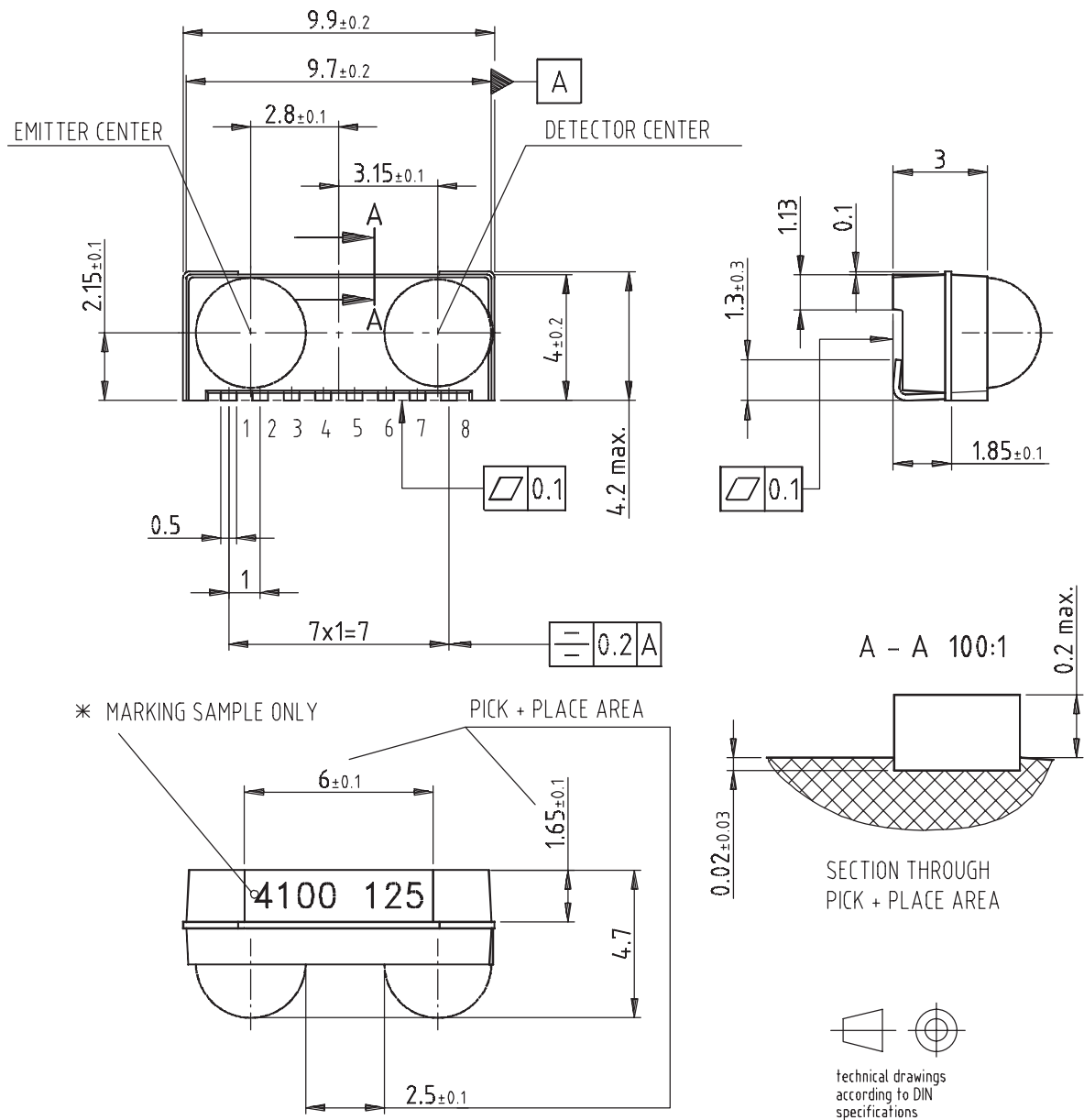

Figure 3. Current Derating Diagram

Figure 3 shows the maximum operating temperature when the device is operated without external current limiting resistor. A power dissipating resistor of $2\ \Omega$ is recommended from the cathode of the IRED to Ground for supply voltages above 4 V. In that case the device can be operated up to 85°C , too.

TFDU4102 – BabyFace (Universal) Package (Mechanical Dimensions)



* MARKING ORIENTATION
 180 DEGREES ALLOWED

Drawing-No.: 6.550-5148.01-4
 Issue: 11; 29.01.01

12249

TFDS4402 – Dracula Package (Mechanical Dimensions)

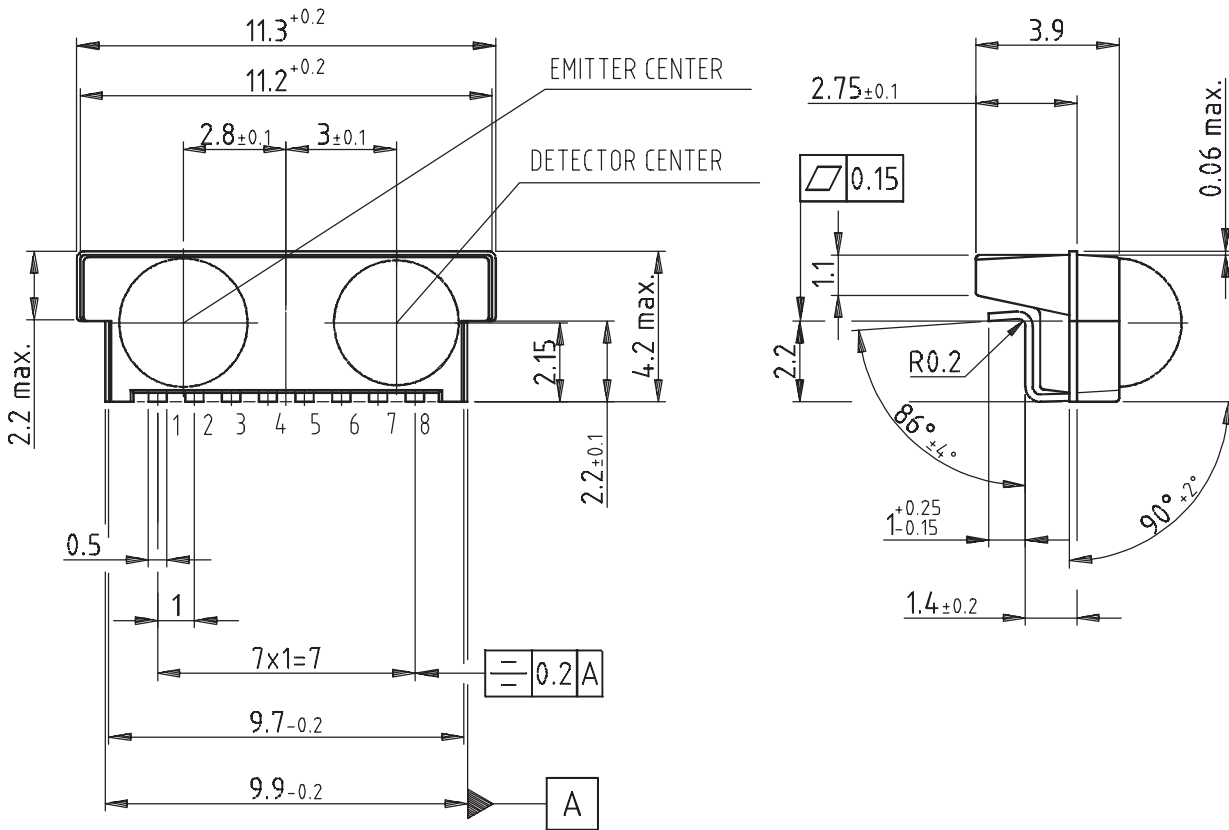

* MARKING SAMPLE ONLY

* MARKING ORIENTATION
180 DEGREES ALLOWED

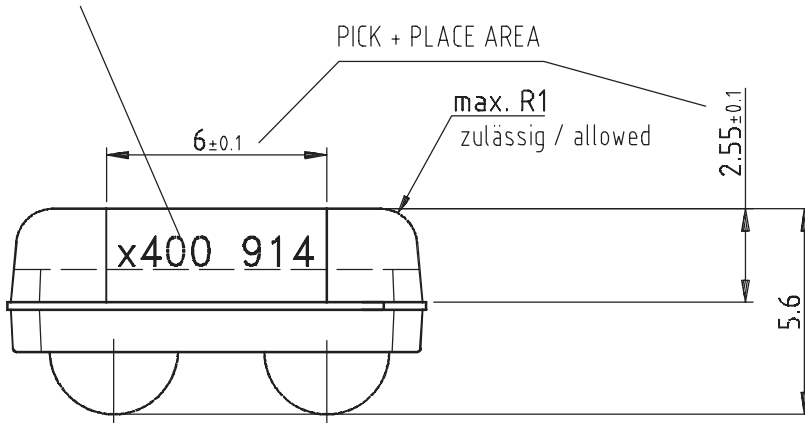

technical drawings
according to DIN
specifications

Drawing-No.: 6.550-5203.01-3
Issue: 2; 03.07.00

15971

Appendix

Application Hints

The TFDx4x02 family does not need any external components when operated at a “clean” power supply. In a more noisy ambient it is recommended to add a capacitor C1 and a resistor R1 for noise suppression. A combination of a tantalum with a ceramics capacitor will be efficient to attenuate both, RF and LF. In the circuit schematics, a resistor R2 is added for decreasing the internal power dissipation. Without that resistor the allowed ambient temperature is limited to 75°C for $V_{ccp} > 4\text{ V}$. With $R2 = 2\ \Omega$ as serial resistor that is increased to 85°C. For higher operating voltages it is used reducing power dissipation inside the device. The power supply V_{ccp} must be able to source up to 550 mA current with a fast rise time. If that cannot be guaranteed an additional capacitor near pin 4 (V_{ccp}) should be included. The value is depended on the power supply quality. A good choice between 4.7 μF and 10 μF .

Shut down

To shut down the TFDU4102 and TFDS4402 into a standby mode the SD pin has to be set active high. In all two versions the Rxd output is floating when the devices are in shut down mode. The Txd input is high impedance in shut down mode.

Recommended Circuit Diagram

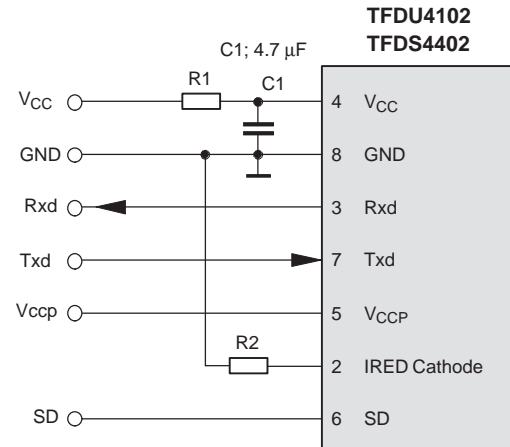

Latency

The receiver is in specified conditions after the defined latency. In a UART related application after that time (typically 50 μs) the receiver buffer of the UART must be cleared. Therefore the transceiver has to wait at least the specified latency after receiving the last bit before starting the transmission to be sure that the corresponding receiver is in a defined state.

For more application circuits, see IrDC Design Guide and TOIM3...-series data sheet

Table 1. Recommended Application Circuit Components

Component	Recommended Value	Vishay Part Number
C1	4.7 μF , 16 V	293D 475X9 016B 2T



Revision History:

A1.0, 21/06/1999: First edition of the target data sheet.

A1.0a, 03/08/1999: Comparison of feature added on page 1, ordering information: pcs per reel changed.

A1.1, 22/09/1999: Babyface and dracula packages added.

A1.3, 26/10/1999: Derating curve included

A1.5, 13/10/2000: Typos corrected



Ozone Depleting Substances Policy Statement

It is the policy of **Vishay Semiconductor GmbH** to

1. Meet all present and future national and international statutory requirements.
2. Regularly and continuously improve the performance of our products, processes, distribution and operating systems with respect to their impact on the health and safety of our employees and the public, as well as their impact on the environment.

It is particular concern to control or eliminate releases of those substances into the atmosphere which are known as ozone depleting substances (ODSs).

The Montreal Protocol (1987) and its London Amendments (1990) intend to severely restrict the use of ODSs and forbid their use within the next ten years. Various national and international initiatives are pressing for an earlier ban on these substances.

Vishay Semiconductor GmbH has been able to use its policy of continuous improvements to eliminate the use of ODSs listed in the following documents.

1. Annex A, B and list of transitional substances of the Montreal Protocol and the London Amendments respectively
2. Class I and II ozone depleting substances in the Clean Air Act Amendments of 1990 by the Environmental Protection Agency (EPA) in the USA
3. Council Decision 88/540/EEC and 91/690/EEC Annex A, B and C (transitional substances) respectively.

Vishay Semiconductor GmbH can certify that our semiconductors are not manufactured with ozone depleting substances and do not contain such substances.

We reserve the right to make changes to improve technical design and may do so without further notice.

Parameters can vary in different applications. All operating parameters must be validated for each customer application by the customer. Should the buyer use Vishay Semiconductors products for any unintended or unauthorized application, the buyer shall indemnify Vishay Semiconductors against all claims, costs, damages, and expenses, arising out of, directly or indirectly, any claim of personal damage, injury or death associated with such unintended or unauthorized use.

Vishay Semiconductor GmbH, P.O.B. 3535, D-74025 Heilbronn, Germany
Telephone: 49 (0)7131 67 2831, Fax number: 49 (0)7131 67 2423



Disclaimer

All product specifications and data are subject to change without notice.

Vishay Intertechnology, Inc., its affiliates, agents, and employees, and all persons acting on its or their behalf (collectively, "Vishay"), disclaim any and all liability for any errors, inaccuracies or incompleteness contained herein or in any other disclosure relating to any product.

Vishay disclaims any and all liability arising out of the use or application of any product described herein or of any information provided herein to the maximum extent permitted by law. The product specifications do not expand or otherwise modify Vishay's terms and conditions of purchase, including but not limited to the warranty expressed therein, which apply to these products.

No license, express or implied, by estoppel or otherwise, to any intellectual property rights is granted by this document or by any conduct of Vishay.

The products shown herein are not designed for use in medical, life-saving, or life-sustaining applications unless otherwise expressly indicated. Customers using or selling Vishay products not expressly indicated for use in such applications do so entirely at their own risk and agree to fully indemnify Vishay for any damages arising or resulting from such use or sale. Please contact authorized Vishay personnel to obtain written terms and conditions regarding products designed for such applications.

Product names and markings noted herein may be trademarks of their respective owners.