

IDB31

PLANAR SILICON BIDIRECTIONAL TRIGGER DIODE

SOT-23

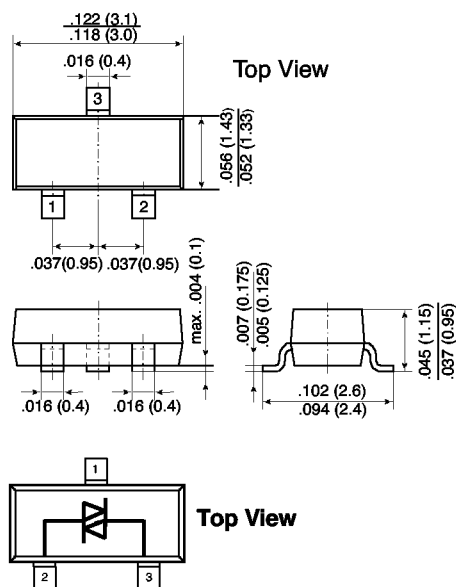

Dimensions in inches and (millimeters)

FEATURES

- ◆ Intend for use in triac and thyristors circuits
- ◆ V_{BO} : 30V to 34V
- ◆ Excellent Breakover Voltage
Symmetry: typ. 1%
- ◆ Low Breakover Current: $20\mu A$ typ.
- ◆ Marking: B31
- ◆ Bidirectional Operation:
Pin 2 and 3 connected to the circuit
Pin 1 has to stay open

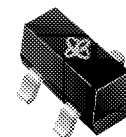

IMPORTANT

Do not connect Pin 1 to ground, VCC or any signal lines.
Pin 1 has to be soldered at a solderpad without any further lines

MECHANICAL DATA

Case: SOT-23 Plastic Package

Weight: approx. 0.008g

Marking code: B31

MAXIMUM RATINGS

In accordance with the Absolut Maximum Rating System (IEC 134).

	SYMBOL	VALUE	UNIT
Power dissipation	P_{tot}	150 (NOTE 1)	mW
Repetitive peak on-state current $t_p=20\mu s$, $f=100Hz$	I_{TRM}	2	Amps
Operating junction temperature range at $t_p < 1$ s, $T_{amb} = 25^\circ C$	T_J	-40 to +125	$^\circ C$
Storage temperature range	T_S	-40 to +125	$^\circ C$
Thermal resistance junction to ambient air	R_{thA}	400 (NOTE 1)	$^\circ C/W$

NOTES:

(1) Device on fiberglass substrate, see layout in Fig. 4

ELECTRICAL CHARACTERISTICS

at $T_J = 25\text{ }^\circ\text{C}$, unless otherwise specified; electrical characteristics applicable in both, forward and reverse direction

	SYMBOL	MIN.	TYP.	MAX.	UNIT
Breakover Voltage see Fig. 1	V_{BO}	30	32	34	Volts
Breakover Voltage Symmetry see Fig. 1	$ V_{BO1} - V_{BO2} $	-	-	± 2	Volts
Dynamic Breakback Voltage (I_{BO} to $I_F=10\text{mA}$), see Fig. 1	$ \Delta V $	5	8	-	Volts
Output Voltage see Fig. 2	V_O	5	-	-	Volts
Breakover Current see Fig. 1	I_{BO}	4	20	50	μA
Rise time see Fig. 3	t_r	-	100	-	ns
Leakage current $V_B=0,5 \cdot V_{BO}$ max. see Fig. 1	I_B	-	-	0.5	μA

FIG. 1 - CURRENT-VOLTAGE CHARACTERISTICS

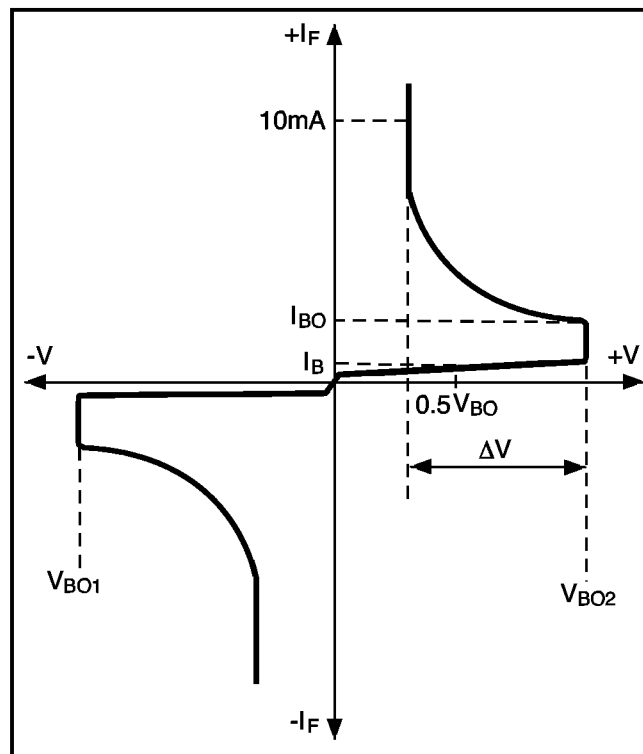

RATINGS AND CHARACTERISTIC CURVES IDB31

FIG. 2 - TEST CIRCUIT

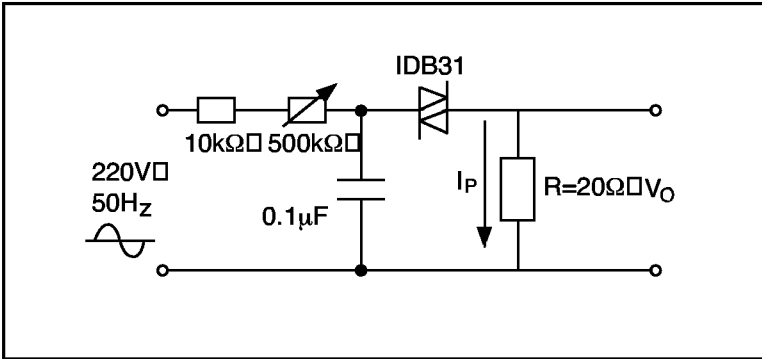

FIG. 3 - TEST CIRCUIT SEE FIG. 1
ADJUST R FOR $I_P=0.5A$

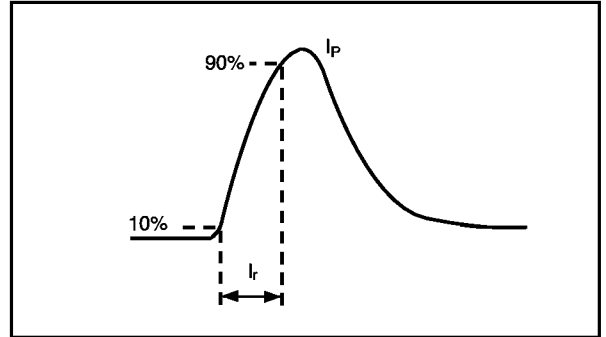

FIG. 4 - Layout for R_{th} test
Dimensions in mm
Thickness:
Fiberglass 1.5mm
Cu leads 0.3mm

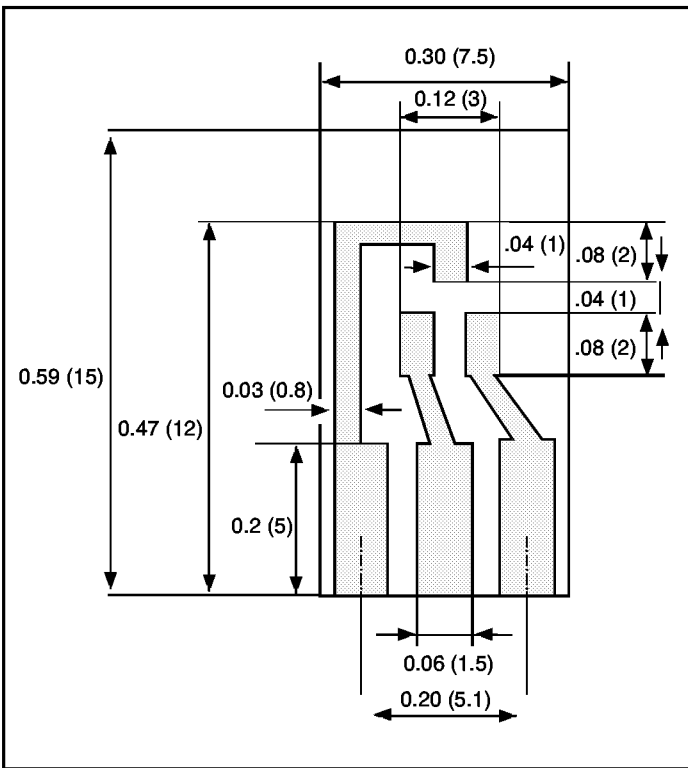

FIG. 5 - ADMISSIBLE POWER DISSIPATION VERSUS AMBIENT TEMPERATURE

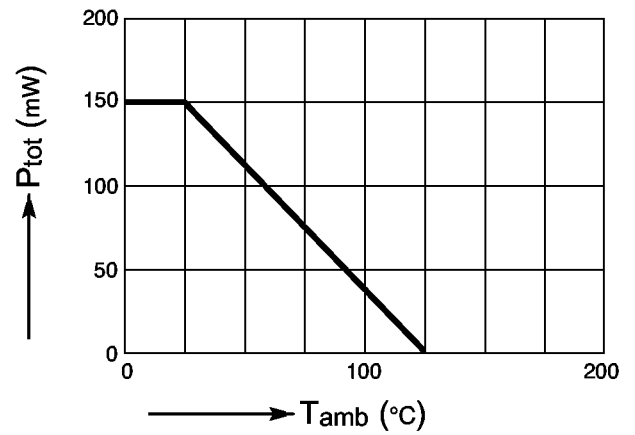

FIG. 6 - RELATIVE VARIATION OF V_{BO} vs. T_j

