

T-33-09

V.H.F. POWER TRANSISTOR

N-P-N silicon planar epitaxial transistor for use in class-A, B and C operated mobile, industrial and military transmitters with a supply voltage of 13,5 V. The transistor is resistance stabilized and is guaranteed to withstand severe load mismatch conditions with a supply over-voltage to 16,5 V.

It has a ¼" capstan envelope with a moulded cap. All leads are isolated from the stud.

QUICK REFERENCE DATA

R.F. performance up to $T_{mb} = 25\text{ }^{\circ}\text{C}$ in an unneutralized common-emitter class-B circuit.

mode of operation	V_{CE} V	f MHz	P_L W	G_p dB	η %	\bar{z}_i Ω	\bar{Y}_L mS
c.w.	13,5	175	15	> 7,5	> 65	2,3 + j2,2	128 - j4,4
c.w.	12,5	175	15	typ. 7,5	typ. 65	-	-

MECHANICAL DATA

Dimensions in mm

Fig. 1 SOT-48/2.

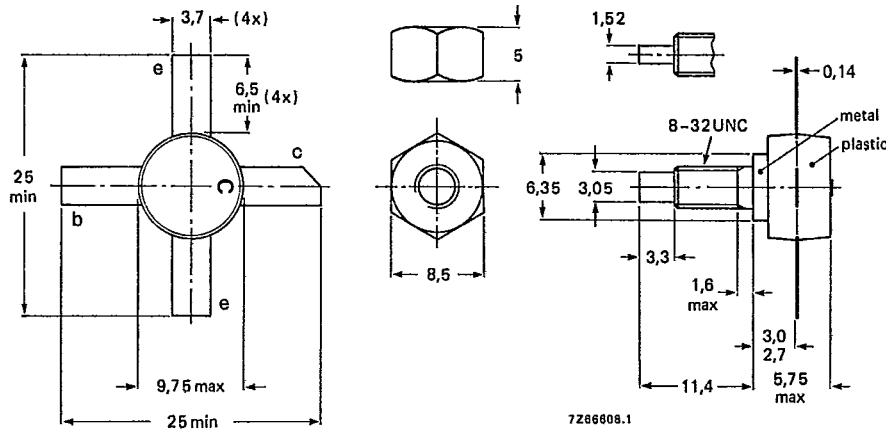

Torque on nut: min. 0,75 Nm
(7,5 kg cm)
max. 0,85 Nm
(8,5 kg cm)

Diameter of clearance hole in heatsink: max. 4,2 mm.
Mounting hole to have no burrs at either end.
De-burring must leave surface flat; do not chamfer or
countersink either end of hole.

When locking is required an adhesive is preferred instead of a lock washer.

PRODUCT SAFETY This device incorporates beryllium oxide, the dust of which is toxic. The device is entirely safe provided that the BeO disc is not damaged.

RATINGS Limiting values in accordance with the Absolute Maximum System (IEC 134).

Collector-base voltage (open emitter) peak value	V_{CBOM}	max.	36	V
Collector-emitter voltage (open base)	V_{CEO}	max.	18	V
Emitter-base voltage (open collector)	V_{EBO}	max.	4	V
Collector current (average)	$I_{C(AV)}$	max.	2.5	A
Collector (peak value) $f > 1$ MHz	I_{CM}	max.	7.5	A
Total power dissipation up to $T_h = 25$ °C $f > 1$ MHz	P_{tot}	max.	32	W

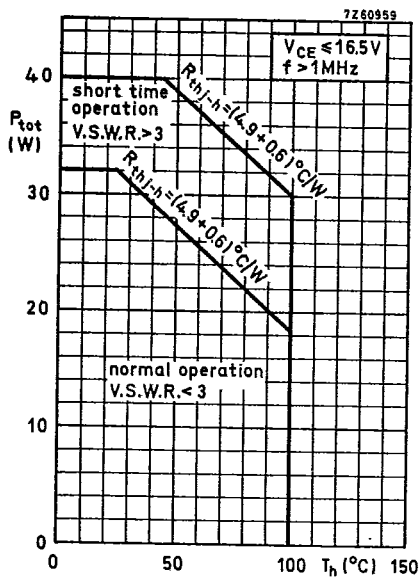
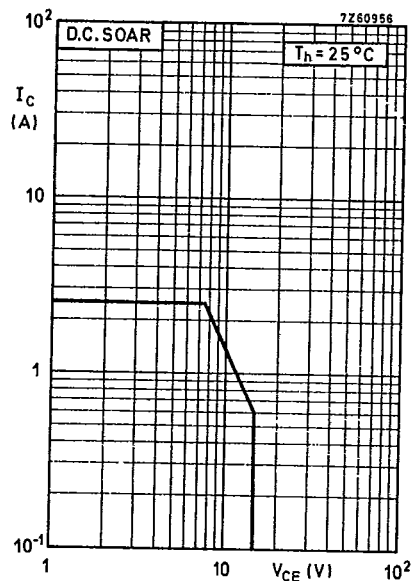

Storage temperature	T_{stg}	-30 to +200	°C
Operating junction temperature	T_j	max. 200	°C

THERMAL RESISTANCE

From junction to mounting base	$R_{th\ j-mb}$	=	4.9	K/W
From mounting base to heatsink	R_{mb-h}	=	0.6	K/W

CHARACTERISTICS

 $T_j = 25\text{ }^\circ\text{C}$ unless otherwise specified

Collector cut-off current

 $I_B = 0; V_{CE} = 14\text{ V}$ $I_{CEO} < 10\text{ mA}$

Breakdown voltages

Collector-base voltage
open emitter, $I_C = 3\text{ mA}$ $V_{(BR)CBO} > 36\text{ V}$ Collector-emitter voltage
open base, $I_C = 25\text{ mA}$ $V_{(BR)CEO} > 18\text{ V}$ Emitter-base voltage
open collector; $I_E = 3\text{ mA}$ $V_{(BR)EBO} > 4\text{ V}$

Transient energy

 $L = 25\text{ mH}; f = 50\text{ Hz}$ open base
 $-V_{BE} = 1.5\text{ V}; R_{BE} = 33\ \Omega$ $E > 2.0\text{ ms}$
 $E > 4.5\text{ ms}$

D. C. current gain

 $I_C = 500\text{ mA}; V_{CE} = 5\text{ V}$ $h_{FE} > 5$

Transition frequency

 $I_C = 1\text{ A}; V_{CE} = 10\text{ V}$ f_T typ. 700 MHzCollector capacitance at $f = 1\text{ MHz}$ $I_E = I_e = 0; V_{CB} = 15\text{ V}$ C_c typ. 34 pF
< 40 pFFeedback capacitance at $f = 1\text{ MHz}$ $I_C = 100\text{ mA}; V_{CE} = 15\text{ V}$ $-C_{re}$ typ. 25 pF

Collector-stud capacitance

 C_{cs} typ. 2 pF

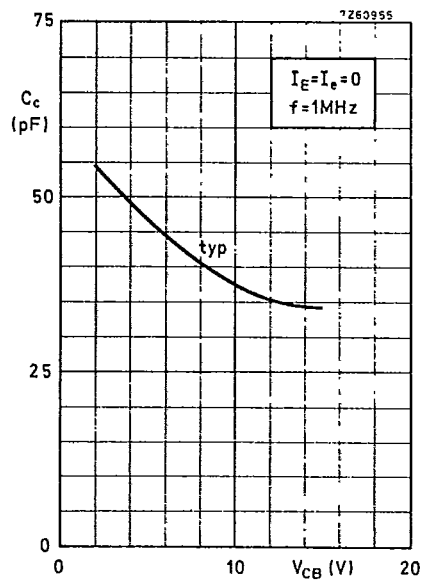
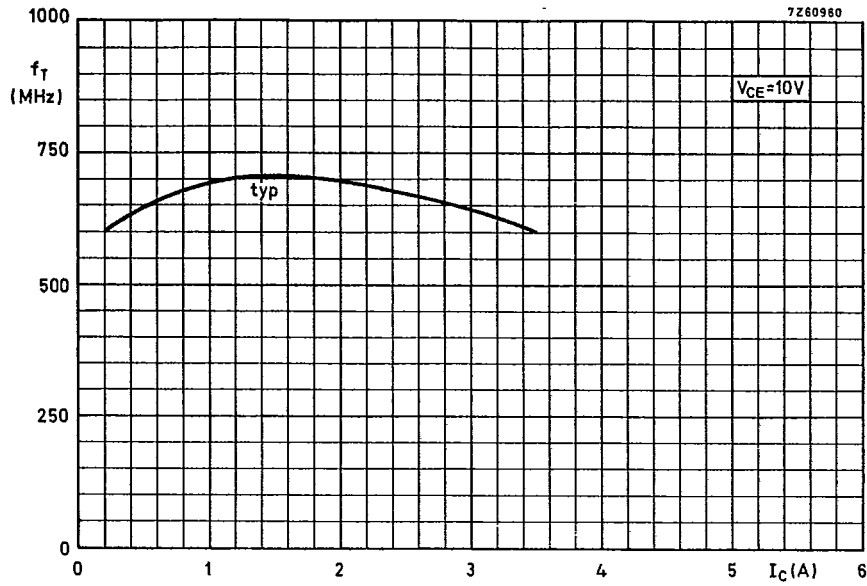

V.H.F. power transistor

BLY88A
T-33-09

APPLICATION INFORMATION

R. F. performance in c. w. operation (unneutralised common-emitter class B circuit)

 $f = 175 \text{ MHz}$; T_{mb} up to 25°C

$V_{CC}(\text{V})$	$P_S(\text{W})$	$P_L(\text{W})$	$I_C(\text{A})$	$G_p(\text{dB})$	$\eta(\%)$	$\bar{z}_i(\Omega)$	$\bar{Y}_L(\text{mS})$
13.5	< 2.65	15	< 1.71	> 7.5	> 65	$2.3 + j2.2$	$128 - j4.4$
12.5	typ. 2.65	15	typ. 1.85	typ. 7.5	typ. 65	—	—

Test circuit

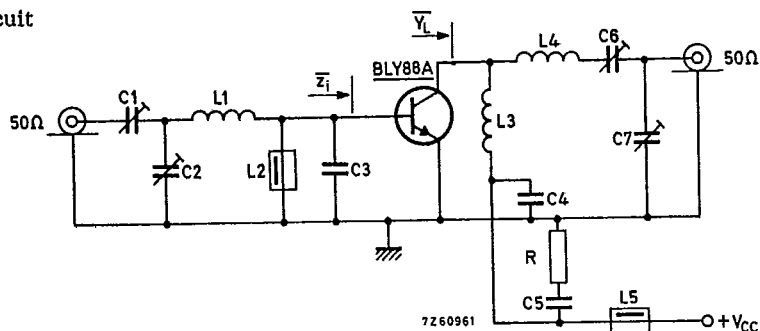

C1= 2.5 to 20 pF film dielectric trimmer (code number 2222 809 07004)

C2=C6=C7= 4 to 40 pF film dielectric trimmer (code number 2222 809 07008)

C3= 47 pF ceramic

C4= 100 pF ceramic

C5= 150 nF polyester

L1= 0.5 turn enamelled Cu wire (1.5 mm); int. diam. 6 mm; leads 2 x 10 mm

L2=L5= ferroxcube choke (code number 4312 020 36640)

L3= 2.5 turns closely wound enamelled Cu wire (1.5 mm); int. diam. 6 mm; leads 2 x 10 mm

L4= 2.5 turns enamelled Cu wire (1.5 mm); int. diam. 6 mm; leads 2 x 10 mm

R = 10 Ω carbon

APPLICATION INFORMATION (continued)

Component lay-out and printed circuit board for 175 MHz test circuit.

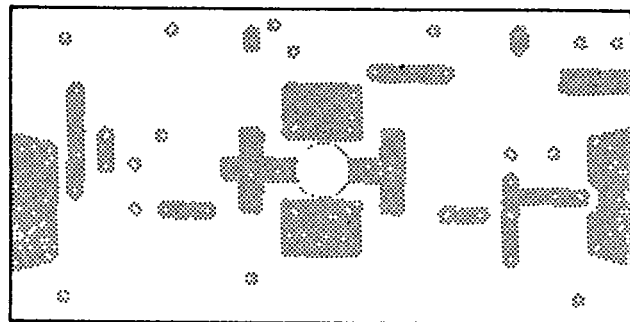
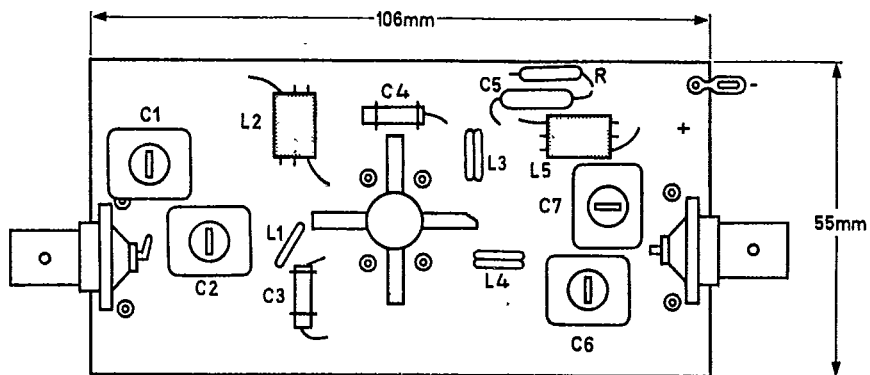

The circuit and the components are situated on one side of the epoxy fibre-glass board, the other side being fully metallised to serve as earth. Earth connections are made by means of hollow rivets.

OPERATING NOTE Below 50 MHz a base-emitter resistor of 10 Ω is recommended to avoid oscillation. This resistor must be effective for both d.c. and r.f.

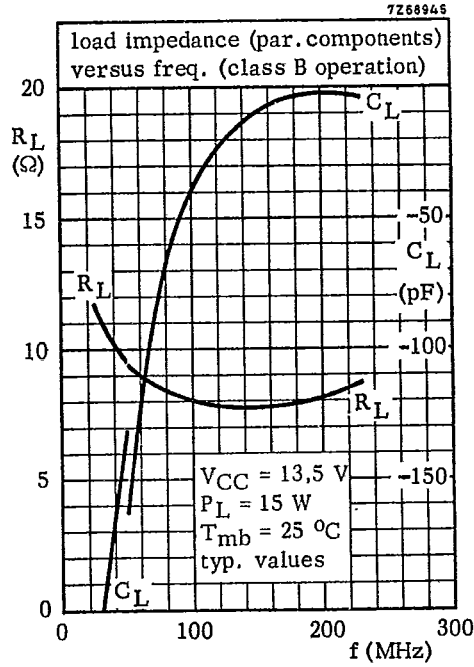
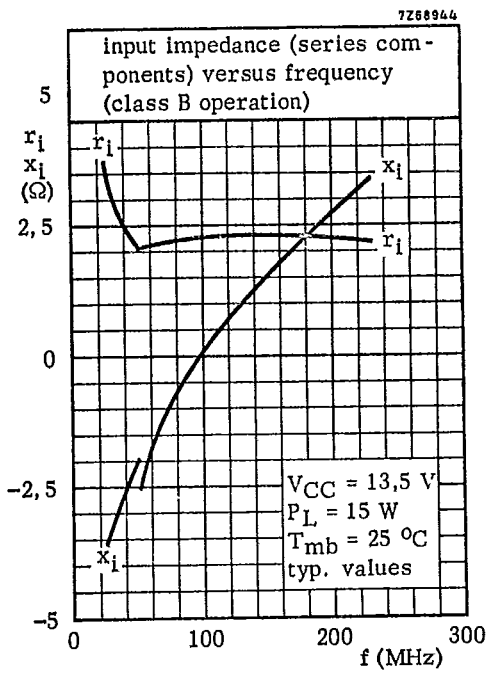
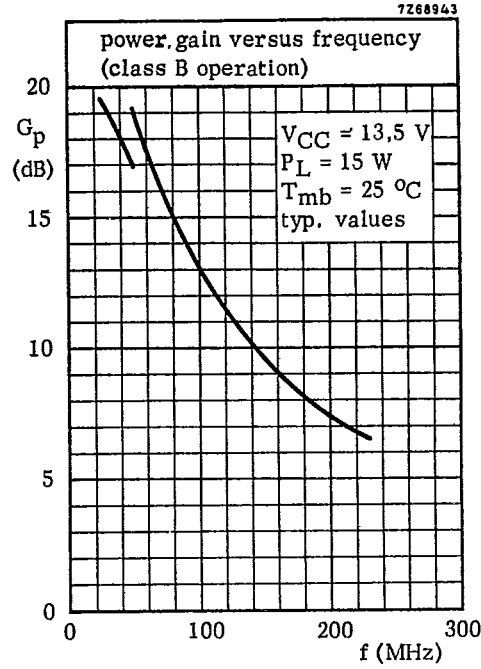
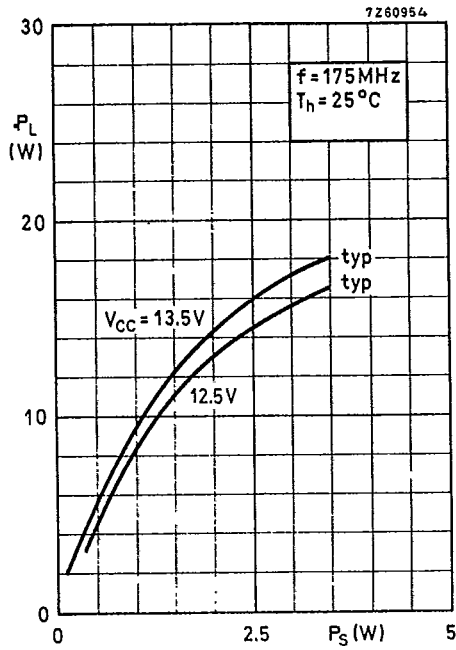

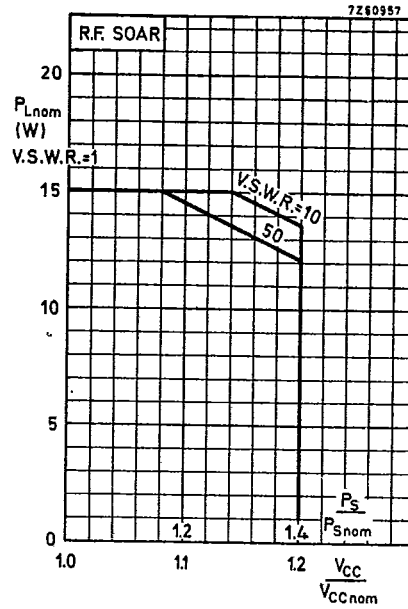
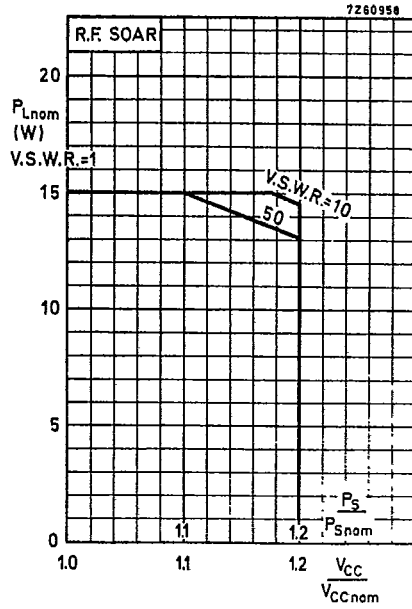

Conditions for R.F. SOAR:

$f = 175 \text{ MHz}$ $P_{Snom} = P_S$ at $V_{CC} = V_{CCnom}$ and $V.S.W.R. = 1$
 $T_h = 70 \text{ }^\circ\text{C}$ $R_{th \text{ mb-h}} = 0.6 \text{ K/W}$
 $V_{CCnom} = 12.5 \text{ or } 13.5 \text{ V}$ see also page 5

The transistor has been developed for use with unstabilized supply voltages. As the output power and drive power increase with the supply voltage, the nominal output power must be derated in accordance with the graphs above for safe operation at supply voltages other than the nominal. The graphs show the allowable output power under nominal conditions, as a function of the supply overvoltage ratio, with V.S.W.R. as parameter.

The left hand graph applies to the situation in which the drive (P_S/P_{Snom}) increases linearly with supply overvoltage ratio.

The right hand graph shows the derating factor to be applied when the drive (P_S/P_{Snom}) increases as the square of the supply overvoltage ratio (V_{CC}/V_{CCnom}).

Depending on the operating conditions, the appropriate derating factor may lie in the region between the linear and the square-law functions.