

Description

Named for Paul Neill of Bell Labs and developed in the 1940's. The Type N offered the first true microwave performance.

Type N connector was developed to satisfy the need for a durable, weatherproof medium size RF connector with consistent performance through 11 GHz.

There are two families of Type N connectors:

- Standard N (Coaxial Cable)
- Helical N (Corrugated Cable)

Primary applications are the termination of medium to miniature size coaxial cable:

RG-8 and RG-225

RG-58 and RG-141

Features/Benefits

- Accommodates a wide range of medium to miniature sized RG coaxial cables in a rugged medium size design. Provides customer flexibility in their design and manufacturing with a durable connector.
- Broad line of Military (M39012 prefix), Industrial (UG prefix), and Commercial Grade (RFX suffix) products available. Gives customer choices in weighing cost versus performance benefits.
- Available in many styles: Plugs (Straight and Right Angle) and Jacks (Panel Mount, Bulkhead Mount, Receptacle). Meets many customer application demands.

Application

- Antennas
- Base Stations
- Broadcast
- Cable Assemblies
- Components
- Instrumentation
- Mil-Aero
- Radar
- Radios
- Satcom
- Surge Protection
- WLAN



Type N

Specifications	226
Cable Plugs	227
Right Angle Plugs	228
Jacks	229-232
Receptacles, Accessories	234-235
Adapters	236

Helical N Corrugated Cable Connectors

Specifications	239
Plugs	240-241
Jacks	242-243

ELECTRICAL

Impedance	50 ohms
Frequency range	0-11 GHz
Voltage rating	1,500 volts peak
Dielectric withstanding voltage	2,500 volts rms.
VSWR (MIL-C-39012 cable connectors)	M39012 straight connectors: 1.3 max. 0-11 GHz M39012 right angle: 1.35 max. 0-11 GHz
Other	Contact resistance: center contact 1.0 milliohm outer contact 0.2 milliohm RF leakage: -90 dB minimum at 3 GHz Insertion loss: .15 dB maximum at 10 GHz Insulation resistance: 5000 megohms minimum

MECHANICAL

Mating	5/8-24 threaded coupling
Cable affixment (braid or jacket)	All crimps: hex braid crimp. Clamps: screw-thread nut and braid clamp
Cable affixment (center conductor)	Crimp: crimp or solder All others: solder only
Captivated contact	All crimps. Others, where specified.
Cable retention	Crimps: 60-120 lbs. Clamps: 30-70 lbs.

MATERIAL

Contacts	Male: brass; Female: phosphor bronze or beryllium copper. Silver or gold plated
Other metal parts	Brass: ASTROplate® finish except M39012 silver.
Insulators	TFE, copolymer of styrene or glass-TFE (hermetic seal)
Weatherproof gaskets	Silicone rubber or synthetic rubber
Crimp ferrule	Copper

ENVIRONMENTAL

Temperature range	TFE -65°C to + 165°C Copolymer of Styrene: - 55°C to + 85°C
Weatherproof	All series N with gaskets are weatherproof
Hermetic seals	Pass helium leak test of 2 X 10 ⁻⁸ cc/sec
Pressurized Shock	Compression seal MIL-Std. 202 method 213
Vibration	MIL-Std. 202 method 204 (test cond. B)
Moisture resistance	MIL-Std. 202 method 106
Corrosion	MIL-Std. 202 method 101 (test cond. B)
Temperature cycling	MIL-Std. 202 method 102 (test cond. C)
Altitude	MIL-Std. 202 method 105 (test cond. C)

MILITARY SPECIFICATIONS

MIL-C-39012 & MIL-A-55339	Where applicable
---------------------------	------------------

NOTE: These characteristics are typical and may not apply to all connectors.

PLUG

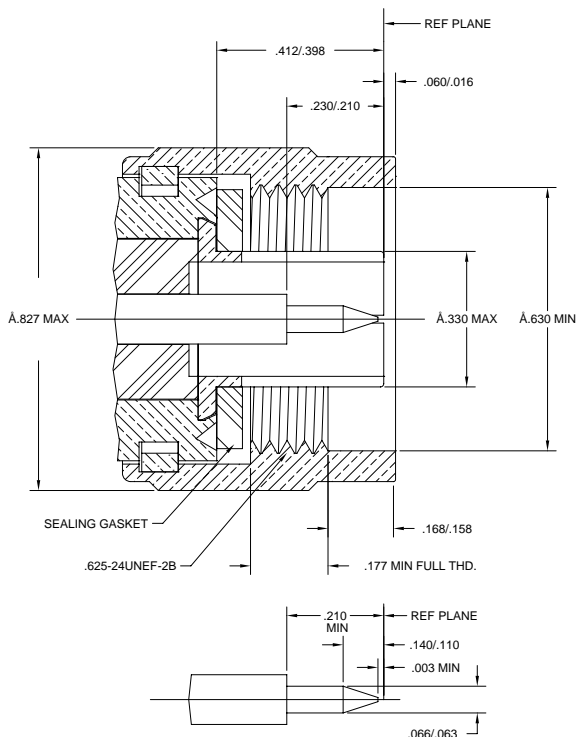

JACK

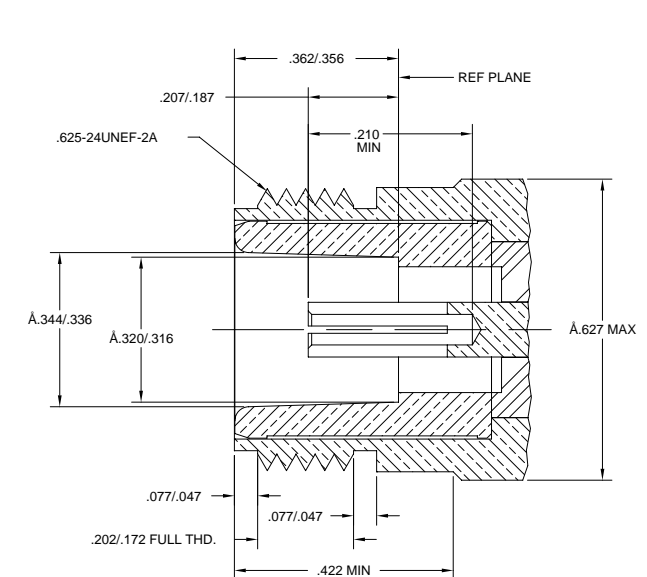

Fig. 1

Crimp-Crimp N Plugs

82-332	82-4425-1003	82-5370
82-340	82-4426	82-5375
82-340-1052	82-4426-11RFX	82-5375-RFX
82-340-1054	82-4427	82-5380-RFX
82-4425	82-4427-1006	82-6152

Fig. 2

Clamp N Plugs

82-202	34025
82-202-RFX	34025-RFX
82-3202	82-202-1006
82-312	82-6034

Fig. 3

Crimp-Crimp N Plugs

82-6142-1000	82-6106
82-5993	82-6010

Fig. 4

Solder-Solder N Plugs

82-5955-RFX
82-5956-RFX
82-6124

N CABLE PLUGS

Cable RG-/U	Cable Attachment		Dimensions, inches (millimeters)			Construction Notes				Military Number	Amphenol Number	Fig.
	Outer	Inner	a	b	c •	CAI	Plt.	Ins.				
8, 213	Crimp	Crimp	1.48(37.7)■	.827(21.0)	.418(10.6)	C11	P33	D1	Lockwire Holes	M39012/01B0007	82-340	1
8, 9, 144, 165, 213	Clamp	Solder	1.50(38.1)	.827(21.0)	.444(11.3)	C8	P1	D9	Lockwire Holes	UG-21E/U	82-3202	2
	Clamp	Solder	1.50(38.1)	.827(21.0)	.444(11.3)	C8	P1	D1	Captivated Cont.	UG-1185/U	82-312	2
8, 9, 144, 165, 213, 214, 216, 225	Clamp	Solder	1.50(38.1)	.827(21.0)	.444(11.2)	C8	P1	D1	Lockwire Holes	UG-21D/U	82-202	2
	Clamp	Solder	1.50(38.1)	.827(21.0)	.437(11.1)	C8	P7	D1	—	—	82-202-RFX	2
9, 214	Crimp	Crimp	1.48(37.7)■	.827(21.0)	.438(11.1)	C11	P34	D1	Lockwire Holes	M39012/01B0008	82-332	1
9, 214, 225, 393	Crimp	Crimp	1.54(39.1)■	.827(21.0)	.438(11.1)	C11	P15	D1	—	—	82-4425-1003	1
55, 142, 223	Crimp	Crimp	1.37(34.9)■	.827(21.0)	.220(5.6)	C11	P15	D1	Lockwire Holes	—	82-5370	1
58, 141	Crimp	Crimp	1.48(37.7)■	.827(21.0)	.206(5.2)	C11	P17	D1	Lockwire Holes	—	82-5375	1
	Crimp	Crimp	1.36(34.6)■	.827(21.0)	.210(5.3)	C11	P7	D1	—	—	82-5375-RFX	1
58, 141, 142A, 400	Clamp	Solder	1.38(34.9)	.827(21.0)	.219(5.4)	C8	P1	D1	Lockwire Holes	UG-536B/U	34025	2
	Clamp	Solder	1.31(33.2)	.827(21.0)	.212(6.4)	C8	P7	D1	—	—	34025-RFX	2
142, 142B, 400	Crimp	Crimp	1.38(35.0)■	.827(21.0)	.220(5.6)	C11	P15	D1	—	—	82-4427-1006	1
142, 400	Crimp	Crimp	1.45(36.9)■	.827(21.0)	.220(5.6)	C11	P34	D1	Lockwire Holes	M39012/01-0503	82-4427	1
213	Crimp	Crimp	1.45(36.9)■	.827(21.0)	.418(10.6)	C11	P34	D1	Lockwire Holes	M39012/01-0502	82-4426	1
214, 225, 393	Crimp	Crimp	1.45(36.9)■	.827(21.0)	.438(11.1)	C11	P33	D1	Lockwire Holes	M39012/01-0501	82-4425	1
Belden 9913, 9914	Crimp	Crimp	1.48(37.7)■	.827(21.0)	.418(10.6)	C11	P15	D1	—	—	82-340-1052	1
B9913, Amph TWB 4001	Clamp	Solder	1.50(38.1)	.827(21.0)	.443(11.2)	C8	P1	D1	—	—	82-202-1006	2
LMR400, TWB 4001	Crimp	Crimp	1.49(37.8)■	.850(21.6)	.418(10.6)	C11	P1	D9	Hex Coupling	—	82-6142-1000	3
LMR600, TWB 6001	Crimp	Crimp	1.98(50.3)■	.930(23.6)	.625(15.9)	C11	P34	D9	Hex Coupling	—	82-5993	3
LMR240, TWB 2401	Crimp	Crimp	1.41(35.8)■	.850(21.6)	.261(6.6)	C11	P15	D1	Hex Coupling	—	82-6106	3
LMR240, TWB 2401	Crimp	Preassy	1.41(35.8)■	.850(21.6)	.261(6.6)	C11	P34	D1	Hex Coupling	—	82-6010	3
59, 62	Crimp	Crimp	1.36(34.6)■	.827(21.0)	.261(6.6)	C11	P7	D1	—	—	82-5380-RFX	1
174, 188, 316	Crimp	Crimp	1.41(35.8)■	.827(21.0)	.125(3.2)	C11	P7	D1	—	—	82-6034	3
LMR 240, TWB2401	Crimp	Crimp	1.17(29.8)	.827(21.0)	.220(5.6)	C11	P7	D1	—	—	82-6152	1
402 (.141 S/R)	Solder	Solder	1.19(30.3)	.826(21.0)	.141(3.6)	C9	P7	D1	—	—	82-5955-RFX	4
405 (.086 S/R)	Solder	Solder	1.19(30.3)	.826(21.0)	.086(2.2)	C9	P7	D1	—	—	82-5956-RFX	4
401 (.250 S/R)	Solder	Solder	1.19(30.3)	.826(21.0)	.250(6.35)	C9	P7	D1	—	—	82-6124	4
Ethernet▼ Cables Times AA4478(FEP), AA4479(PVC); Belden 89880(FEP), 9880(PVC)	Crimp	Crimp	1.48(37.7)■	.827(21.0)	.437(11.1)	C11	P7	D1	—	—	82-4426-11RFX	1

• accommodates cable diameter ■ includes outer ferrule ▼ Ethernet = Xerox Trademark ▲ Distributor stocked

Fig. 1

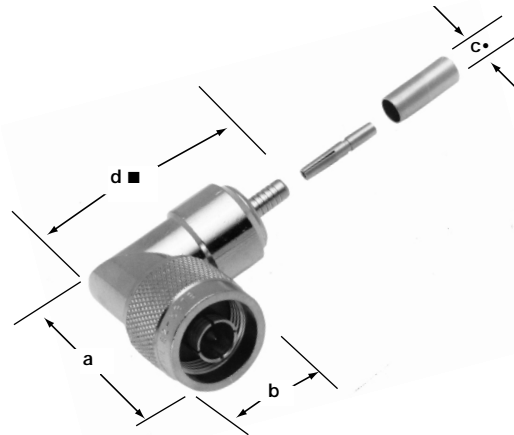

Crimp N Angle Plugs
82-4440-1001 82-5995
82-5374 82-4440

Fig. 2

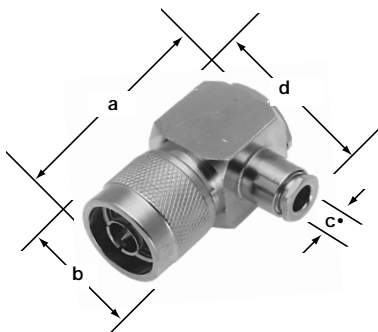

Clamp N Angle Plug
Cubic Body
18750
82-5988-1000

Fig. 3

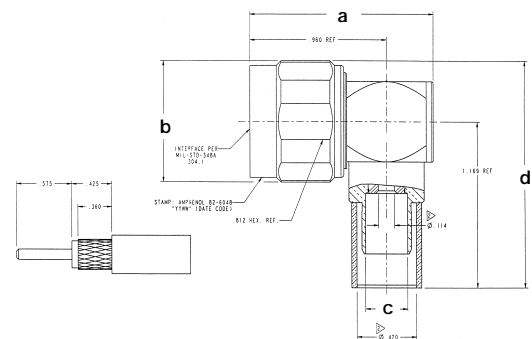

Crimp N Angle Plug
Cubic Body
82-6048-1000
82-5989-1004
82-6157
82-6165
82-6166

N RIGHT ANGLE PLUGS

Cable RG-/U	Cable Attachment		Dimensions, inches (millimeters)				Notes			Military Number	Amphenol Number	Fig.
	Outer	Inner	a	b	c •	d	CAI	Pit.	Ins.			
9, 214, 225, 393	Crimp	Crimp	1.40(35.5)	.827(21.0)	.437(11.1)	1.95(49.5)■	C11	P28	D1	—	82-4440-1001	1
55, 142, 223	Crimp	Crimp	1.41(35.7)	.827(21.0)	.220(5.6)	1.98(50.2)■	C11	P11	D1	—	82-5374	1 ▲
58, 141, 142	Clamp	Solder	1.63(41.3)	.827(21.0)	.210(5.3)	1.22(31.0)	C8	P1	D1	—	18750	2
214, 225, 393	Crimp	Crimp	1.40(35.5)	.827(21.0)	.438(11.1)	1.95(49.5)■	C11	P33	D1	M39012/05-0501	82-4440	1 ▲
214, 393	Crimp	Solder	1.195(30.4)	.827(21.0)	.438(11.1)	1.62(4.1)■	C11	P33	D9	—	82-5988-1000	2
214, 393	Crimp	Solder	1.195(30.4)	.850(21.6)	.438(11.1)	1.62(4.1)■	C11	P33	D9	Hex Coupling	82-5988-1004	3
LMR 600, TWB 6001	Crimp	Solder	1.32(33.5)	.850(21.6)	.625(15.9)	1.61(40.9)■	C11	P34	D9	Hex Coupling	82-5995	1
Amph TWB 4001, LMR 400, Belden 9913	Crimp	Solder	1.291(32.8)	.850(21.6)	.298(7.57)	1.594(40.5)■	C11	P33	D9	—	82-6048-1000	3
LMR 240, 8X	Crimp	Crimp	1.43(36.5)	.827(21.0)	.259(6.6)	1.07(27.2)	C11	P7	D1	Nickel Body	82-6157	3
LMR 240, 8X	Crimp	Crimp	1.43(36.5)	.827(21.0)	.259(6.6)	1.07(27.2)	C11	P7	D1	Nickel Body	82-6165	3
LMR 240, 8X	Crimp	Crimp	1.43(36.5)	.827(21.0)	.259(6.6)	1.07(27.2)	C11	P33	D1	Silver Body	82-6166	3

• accommodates cable diameter ■ includes outer ferrule ▲ Distributor stocked

Type N Straight Jacks

Amphenol®

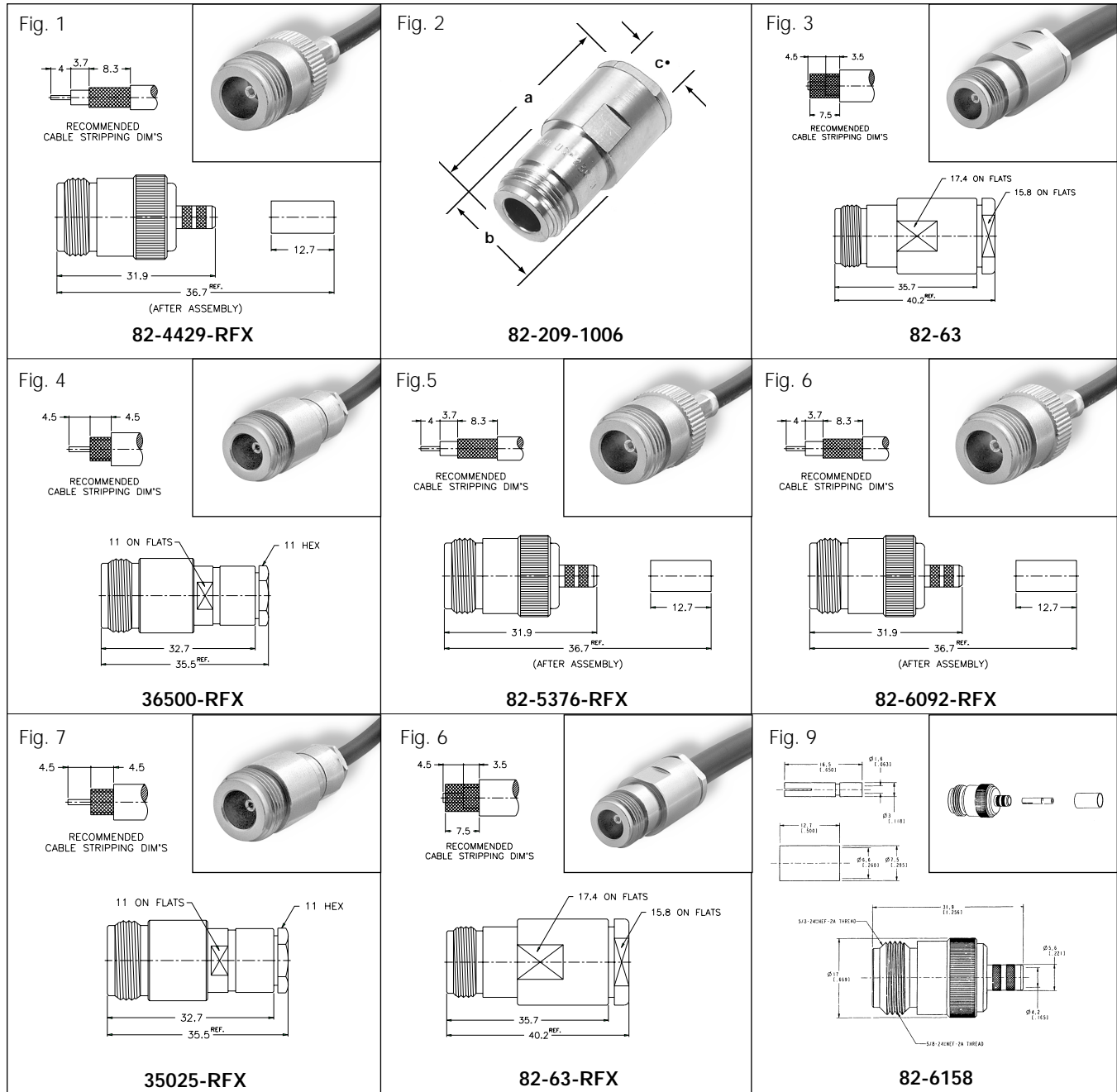

N STRAIGHT JACKS

Cable RG-/U	Conn. Type	Cable Attachment		Dimensions, inches (millimeters)					Notes			Military Number	Amphenol Number	Fig	
		Outer	Inner	a	b	c •	d	e	CAI	Plt.	Ins.				
8, 9, 87A, 144, 165, 213, 214, 216, 225	Str.	Clamp	Solder	1.56(39.7)	.750(19.1)	.440(11.2)	—	—	C8	P1	D1	UG-23B/U	82-63	3	▲
B9913, Times AA-6146	Str.	Clamp	Solder	1.56(39.6)	.750(19.1)	.443(11.3)	—	—	C8	P1	D9	—	82-209-1006	2	
59, 62	Str.	Crimp	Crimp	1.44 (36.7)	.866 (22)	.210 (5.3)	.866 (22)	.250 (64)	—	P7	D1	—	82-5376-RFX	5	
59	Str.	Crimp	Crimp	1.44 (36.7)	—	—	—	—	—	P7	D1	—	82-6092-RFX	6	▲
58, 141	Str.	Clamp	Solder	1.90 (35.5)	.630 (16)	.212 (5.4)	—	—	—	P7	D1	—	35025-RFX	7	▲
8, 213, 214	Str.	Clamp	Solder	1.58 (40.2)	.750 (19)	.437 (11.1)	—	—	—	P7	D1	—	82-63-RFX	8	
59, 62	Str.	Clamp	Solder	.96 (24.5)	.827 (21)	.143 (3.6)	—	—	—	P7	D1	—	36500-RFX	4	
LMR240, 8X	Str.	Clamp	Solder	.96 (24.5)	.827 (21)	.143 (3.6)	—	—	—	P7	D1	—	82-6158	9	
213	Str.	Crimp	Crimp	1.44 (36.6)	.669 (17)	.440 (11.2)	—	—	—	P7	D1	—	82-4429-RFX	1	

• accommodates cable diameter ■ Captivated contact ★ IBM6028495 ▼ max. panel when rear mounted thru panel ▲ Distributor stocked

Type N Panel Mount - 4 Hole Flange

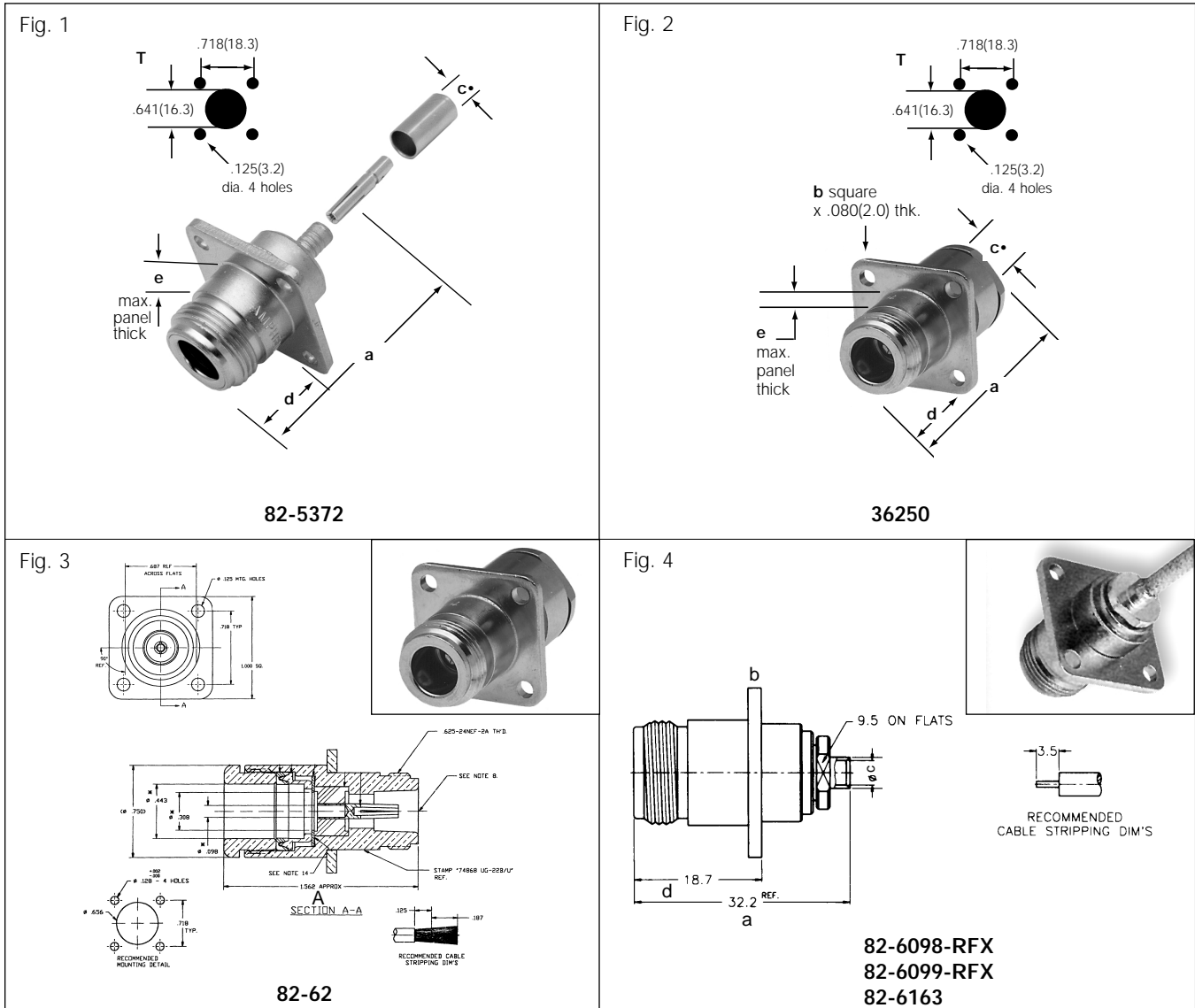

N PANEL JACKS

Cable RG-/U	Conn. Type	Cable Attachment Outer	Cable Attachment Inner	Dimensions, inches (millimeters)					Notes			Mtg Hole	Military Number	Amphenol Number	Fig
				a	b	c •	d	e	CAI	Plt.	Ins.				
55, 141, 142	Panel	Crimp	Crimp	1.56(39.7)	1.00(25.4)	.220(5.6)	.576(14.6)	.125(3.2)▼	C11	P15	D1	T	—	82-5372	2
55, 58, 141,	Panel	Clamp	Solder	1.50(38.1)	1.00(25.4)	.224(5.7)	.656(16.7)	.219(5.6)▼	C8	P1	D1	T	UG-1095A/U	36250	1
8, 9, 87A, 144,165,213, 214,216,225	Panel	Clamp	Solder	1.56(39.7)	1.00(25.4)	.440(11.2)	—	—	C8	P1	D1	—	UG-23B/U	82-62	3
405 (.085) S/R	Panel	Solder	Solder	1.26(32.2)	1.00(25.4)	.086(2.2)	.736(18.7)	—	C9	P7	D1	T	—	82-6098-RFX	4
402 (.141) S/R	Panel	Solder	Solder	1.26(32.2)	1.00(25.4)	.141(3.6)	.736(18.7)	—	C9	P7	D1	T	—	82-6099-RFX	4
401 (.250) S/R	Panel	Solder	Solder	1.26(32.2)	1.00(25.4)	.250(6.35)	.736(18.7)	—	C9	P7	D1	T	—	82-6163	4

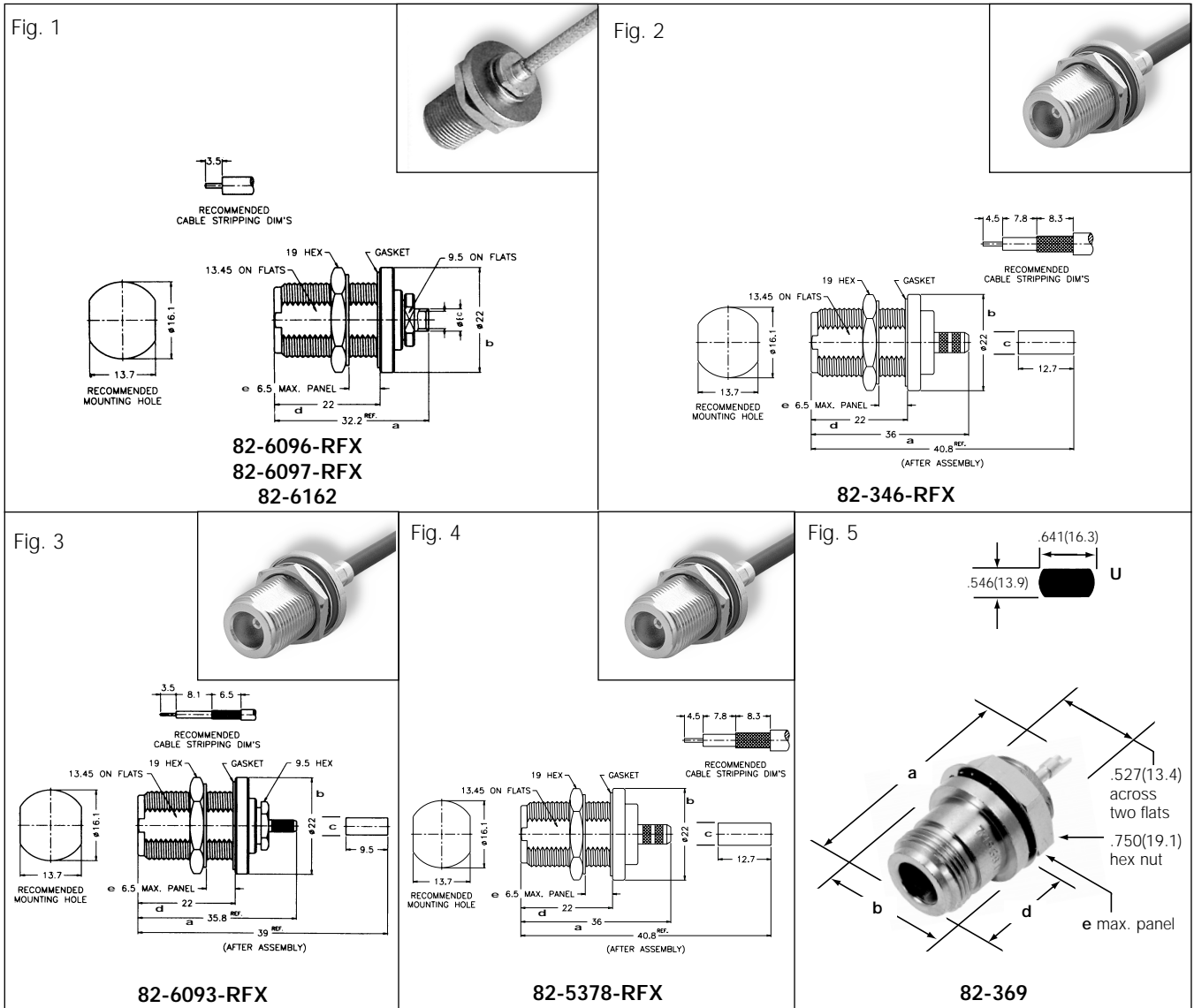

N BULKHEAD JACKS

Cable RG-/U	Cable Attachment		Dimensions, inches (millimeters)					Notes			Mtg Hole	Military Number	Amphenol Number	Fig
	Outer	Inner	a	b	c •	d	e	CAI	Pit.	Ins.				
405 (.085) S/R	Solder	Solder	1.26(32.2)	.866(22.0)	.086(2.2)	.866(22.0)	.255(6.5)	C9	P7	D1	—	—	82-6096-RFX	1
402 (.141) S/R	Solder	Solder	1.26(32.2)	.866(22.0)	.141(3.6)	.866(22.0)	.255(6.5)	C9	P7	D1	—	—	82-6097-RFX	1
401 (.250) S/R	Solder	Solder	1.26(32.2)	.866(22.0)	.250(6.3)	.866(22.0)	.255(6.5)	C9	P7	D1	—	—	82-6162	1
8, 213	Crimp	Crimp	1.41(36.0)	.866(22.0)	.165(4.2)	.866(22.0)	.255(6.5)	C11	P7	D1	—	—	82-346-RFX	2
174, 188, 316	Crimp	Crimp	1.40(35.8)	.866(22.0)	.126(3.2)	.866(22.0)	.255(6.5)	C11	P7	D1	—	—	82-6093-RFX	3
58, 141	Crimp	Crimp	1.40(35.8)	.866(22.0)	.210(5.3)	.866(22.0)	.255(6.5)	C11	P7	D1	—	—	82-5378-RFX	4

N PANEL, ANGLE PANEL & BULKHEAD RECEPTACLES

Description	Terminal Type	Dimensions, inches (millimeters)				Pit.	Ins.	Mtg Hole	Military Number	Amphenol Number	Fig.
		a	b	d	e						
Bulkhead Receptacle (Jack) Front Mount, Hermetically Sealed	Solder Cup	1.58(40.1)	.813(20.6)	.707(18.0)	.209(5.3)	P34	D11	U	M39012/04-0001	82-369	5

Type N Panel Mount Receptacle / Solder Terminal

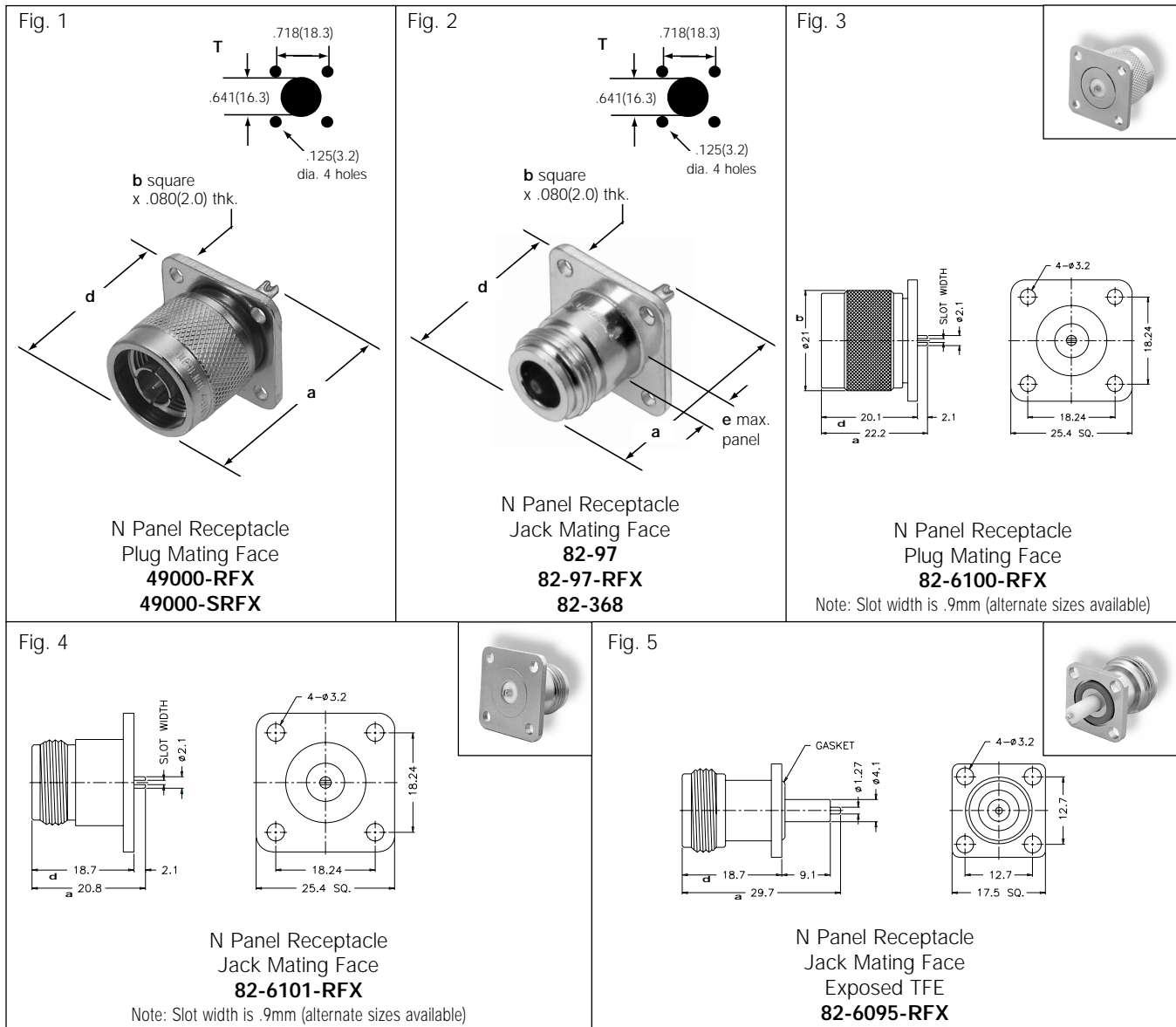

N PANEL, ANGLE PANEL & BULKHEAD RECEPTACLES

Description	Terminal Type	Dimensions, inches (millimeters)				Plt.	Ins.	Mtg Hole	Military Number	Amphenol Number	Fig.
		a	b	d	e						
Panel Receptacle (Jack) 4-hole Square Flange, Front or Rear Mount	Solder Cup	1.11(28.2)	1.00(25.4)	.656(16.7)	.187(4.7)▼	P1	D1	T	UG-58A/U	82-97	2 ▲
	Solder Cup	1.13(28.7)	1.00(25.4)	.656(16.7)	.187(4.7)▼	P7	D1	T	—	82-97-RFX	2 ▲
	Solder Cup	1.11(28.2)	1.00(25.4)	.656(16.7)	.187(4.7)▼	P34	D1	T	M39012/04-0002	82-368	2
Panel Receptacle (Plug) 4-hole Square Flange, Front Mount Only	Solder Cup	1.09(27.8)	1.00(25.4)	.745(18.9)	—	P7	D6	T	—	49000-RFX	1
Panel Receptacle (Plug) 4-hole Square Flange, Front Mount Only	Solder Cup	1.09(27.8)	1.00(25.4)	.745(18.9)	—	P33	D6	T	—	49000-SRFX	1
Panel Receptacle (Plug) 4-hole Square Flange, Front Mount Only	Slotted Post	.874(22.2)	.826(21.0)	.791(20.1)	—	P7	D1	—	—	82-6100-RFX	3
Panel Receptacle (Jack) 4-hole Square Flange, Slot Terminal	Slotted Post	.818(20.8)	—	.736(18.7)	—	P7	D1	—	—	82-6101-RFX	4
Panel Receptacle (Jack) 4-hole Square Flange, Exposed TFE	Exposed TFE	1.16(29.7)	—	.736(18.7)	—	P7	D1	—	—	82-6095-RFX	5

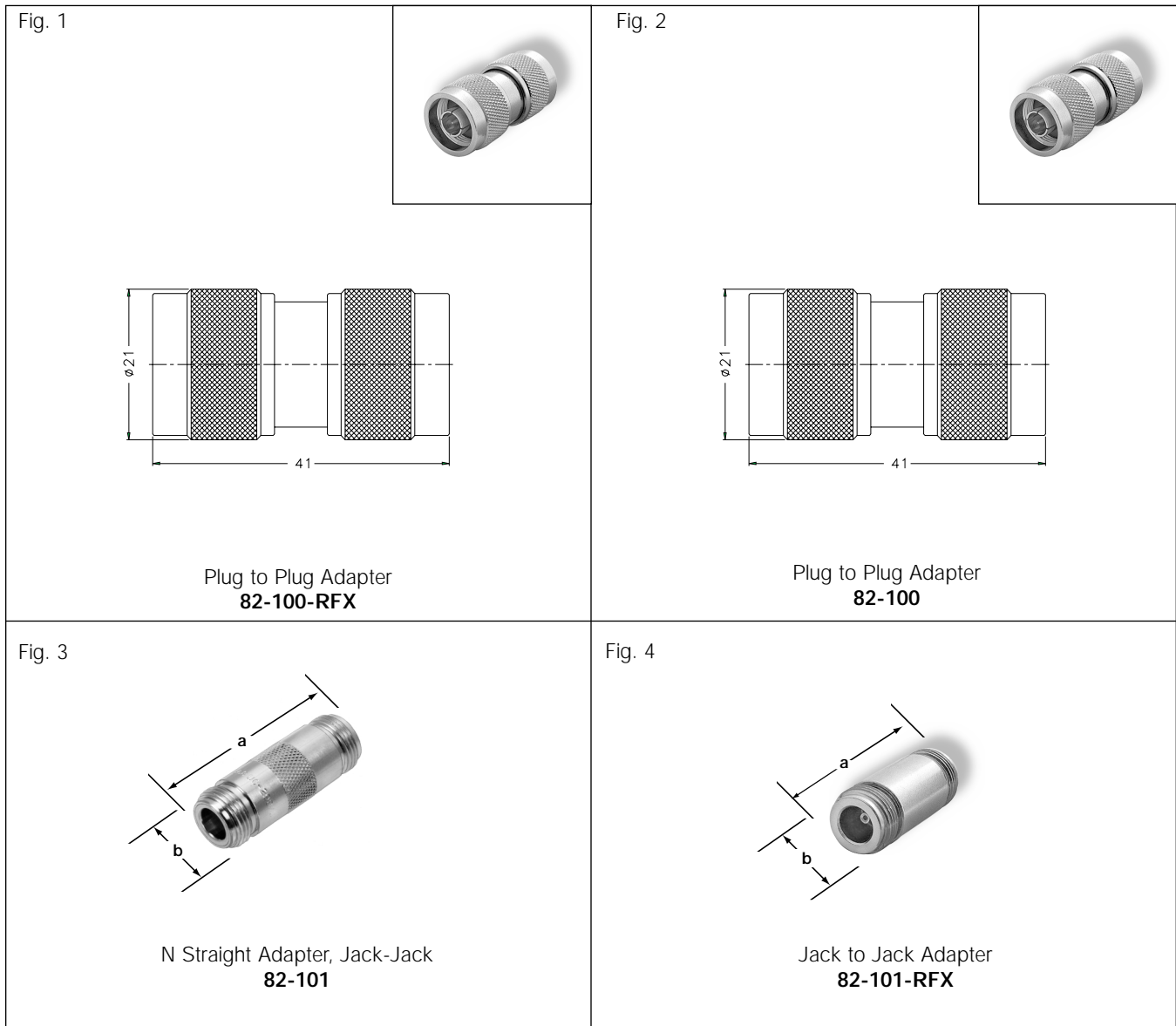

N ADAPTERS

Adapter Ends	Description	Dimensions, inches (millimeters)				Mtg Hole	Construction Notes			Military Number	Amphenol Number	Fig.
		a	b	d	e		Plt.	Ins.	Other			
Plug-Plug	Straight	1.59(40.5)	.813(20.6)	—	—	—	P4	D1	—	UG-57B/U	82-100	1
Plug-Plug	Straight	1.59(40.5)	.813(20.6)	—	—	—	P7	D1	—	UG-57B/U	82-100-RFX	2
Jack-Jack	Straight	1.78(45.2)	.656(16.7)	—	—	—	P1	D1	—	UG-29B/U	82-101	3
Jack-Jack	Straight	1.50(38.1)	.620(15.8)	—	—	—	P1	D1	—	UG-29B/U	82-101-RFX	4

▲ Distributor stocked

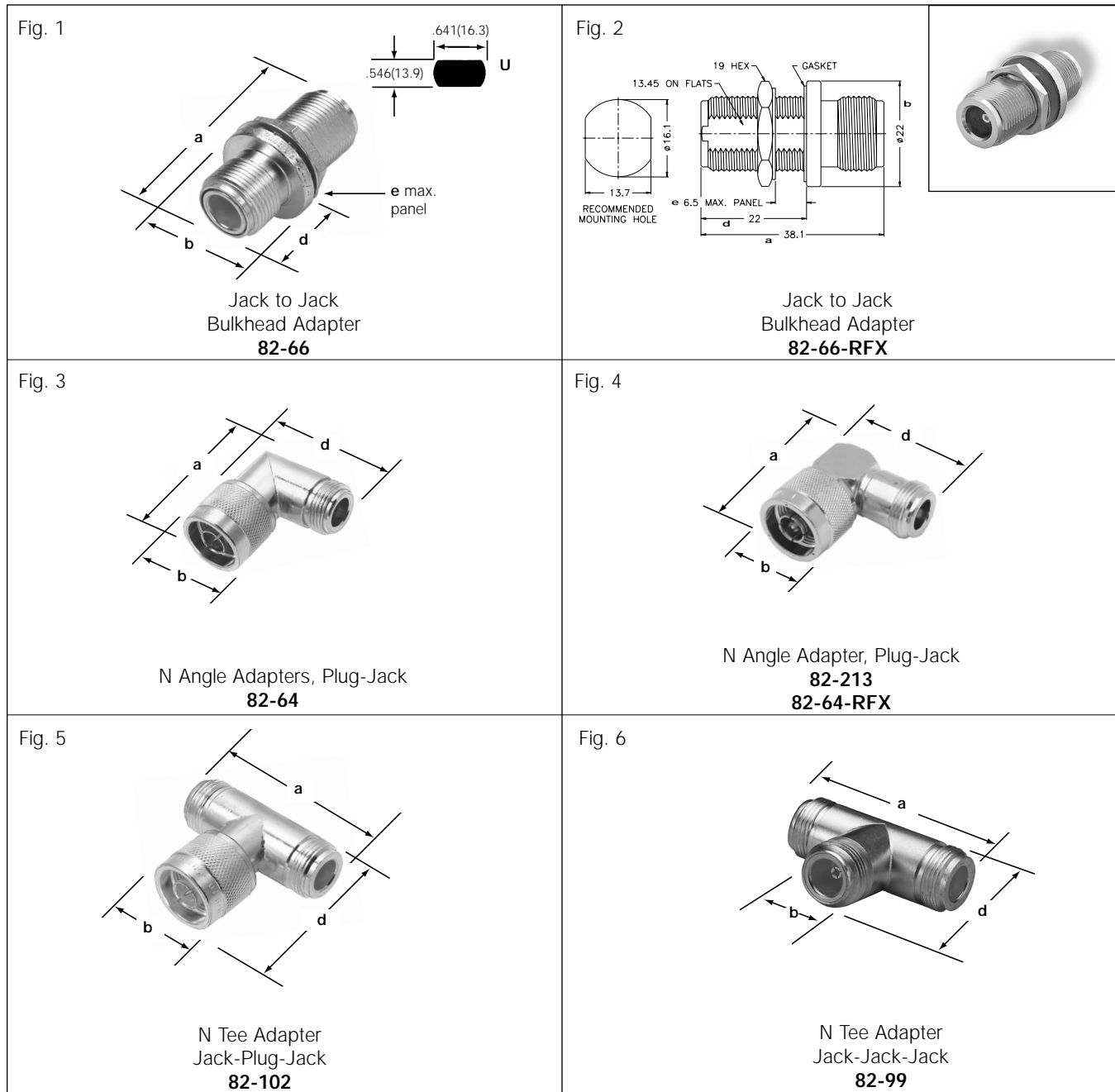

N ADAPTERS

Adapter Ends	Description	Dimensions, inches (millimeters)				Mtg Hole	Construction Notes			Military Number	Amphenol Number	Fig.
		a	b	d	e		Plt.	Ins.	Other			
Jack-Jack	Bulkhead	1.63(41.3)	.813(20.6)	.708(18.0)	.312(7.9)	U	P1	D6	Pressurized	UG-30/U	82-66	1 ▲
Jack-Jack	Bulkhead	1.50(38.1)	.866(22.0)	.866(22.0)	.256(6.5)	U	P1	D6	Pressurized	UG-30/U	82-66-RFX	2 ▲
Jack-Plug	Angle	1.44(36.5)	.813(20.6)	1.37(34.9)	—	—	P1	D1	Mitre Body	UG-27A/U	82-64	3 ▲
Jack-Plug	Angle	1.44(36.5)	.813(20.6)	1.28(32.5)	—	—	P7	D1	Cubic Body	—	82-64-RFX	4 ▲
Plug-Jack	Angle	1.31(33.3)	.813(20.6)	1.40(35.7)	—	—	P1	D1	Cubic Body	UG-27C/U	82-213	4 ▲
Jack-Plug-Jack	Tee	1.75(44.5)	.813(20.6)	1.48(37.6)	—	—	P5	D1	—	UG-107B/U	82-102	5
Jack-Jack-Jack	Tee	1.75(44.5)	.656(16.7)	1.22(31.0)	—	—	P5	D1	—	UG-28A/U	82-99	6

▲ Distributor stocked

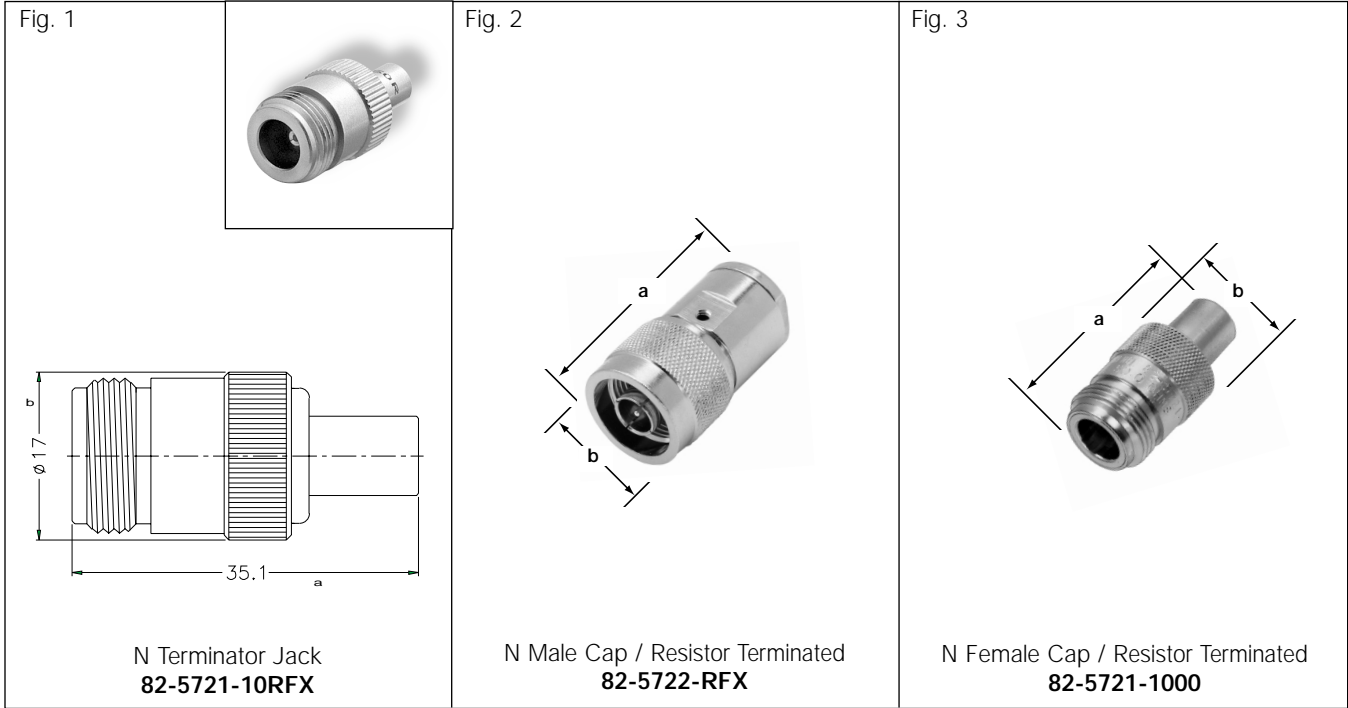

N CAPS

Description	Dimensions, inches (millimeters)		Plt.	Ins.	Military Number	Amphenol Number	Fig.
	a	b					
Male Cap Resistor Terminated, 50Ω 5%, 1 Watt	1.30(33.0)	.827(21.0)	P7	D1	—	82-5722-RFX	2
Female Cap Terminator, 49.9Ω 1%, 1 Watt	1.30(33.0)	.656(15.7)	P17	D1	—	82-5721-1000	3
Female Cap Terminator, 50.0Ω 5%, 1 Watt	1.30(33.0)	.656(15.7)	P17	D1	—	82-5721-10RFX	1

▼ max. panel when rear mounted thru panel ▲ Distributor stocked

Description

Intermodulation Distortion (IMD) is of increasing concern to many Wireless Infrastructure OEMs due to the need for higher power applications and increased receiver sensitivity performance. Having the ability to measure IMD in-house gives Amphenol the unique ability to understand the affects of our connector designs on IMD generation and enabling Amphenol to design the highest performance IMD connectors in the industry.

Our new series of Low Intermodulation N connectors is a result of our efforts in connector design optimization.

Features/Benefits

- Typical IMD -125 dBm
- All components silver plated
- 360° outer contacts
- Gold plated inner contacts
- EZ HEZ™ coupling nut for ease of installation
- Available for 1/4", 3/8" and 1/2" superflexible corrugated cables, and 1/2", 7/8", 1 1/4", 1 5/8", standard flexible corrugated cables
- Consult your Amphenol sales representative for details

Applications

- Cellular
- PCS
- Microwave Radio
- Paging

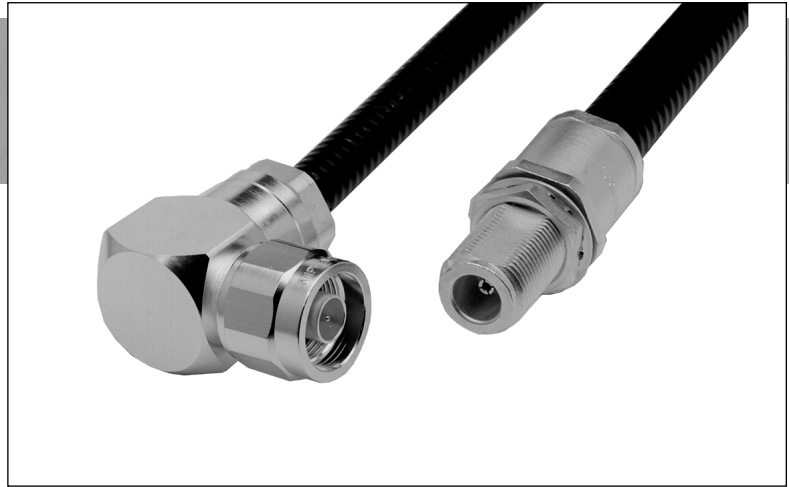

Annular Type N

Specifications	239
Plugs and Jacks	240-243

Type N Corrugated Cable Connectors

RF coaxial connectors are the most important element in your cable system. Corrugated copper coaxial cables have the potential to deliver all the performance your system requires, but they are often limited by the performance of the connectors. TXL coaxial connectors have been designed from the ground up to deliver optimum performance, while retaining ease of installation.

Intermodulation distortion, a major concern in today's communications systems, is consistently low with TXL connectors. Typical performance is -125 dBm (-168 dBc). In-house IMD measurement capability gives Amphenol the unique ability to understand the effects of connector design elements on IMD generation and to design the best performing connectors in the industry.

Self-flaring designs are easily attached with standard hand tools in the field, and are highly resistant to pull off and twist off.

All TXL coaxial connectors are optimally matched to their cables for low VSWR and insertion loss.

Two-Piece Design

All TXL connectors feature a simple two-piece design for easier attachment, and all connectors for a given size share a common back nut and trimming dimensions.

Easy-Hex Coupling Nut

Unique coupling nut design allows tightening by hand or with a standard wrench.

One-Piece Body

Many TXL connectors feature one-piece bodies. The outer conductor contact and connector body are a single piece to minimize IMD generation.

Plated Surfaces

Center contacts are gold or silver plated. Bodies are white bronze plated for excellent IMD performance, and are corrosion resistant for a long, trouble-free life.

Pre-assembled O-Rings

O-rings are pre-assembled to the back nuts, eliminating installation problems and lost parts.

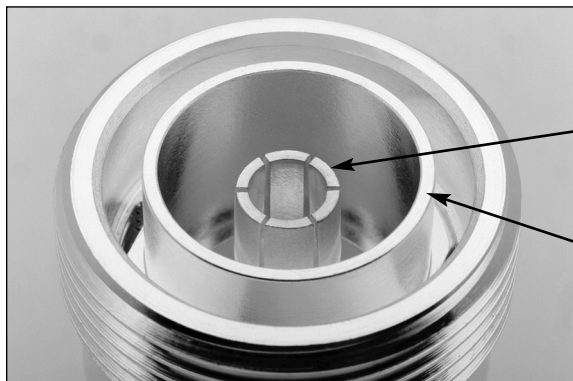
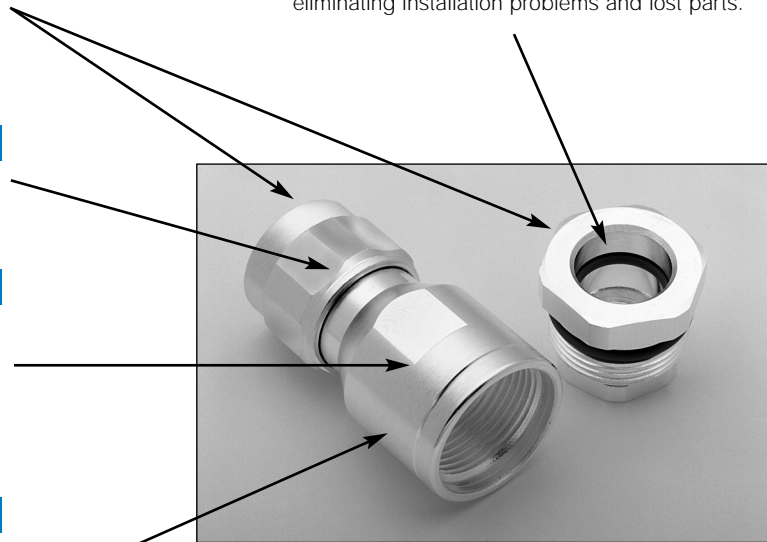

Captive Center Pins

Captive center pins simplify installation and eliminate performance variations due to soldering errors and incorrect pin depths.

360° Contact

Continuous 360° outer conductor contact is proven to minimize IMD generation compared to spring finger contacts.

Type N - Corrugated Specifications

ELECTRICAL

Impedance	50 ohms
Frequency range	11.0 GHz
Return Loss (Freq. GHz)	33 dB (1-2 GHz) 28 dB (2-3 GHz)
Operating voltage	max. 707 vrms
Dielectric withstanding voltage	2,000 vdc
Other	Peak power: max 10kW Avg. power: max .60kW Insulation resistance: min 5,000 MOhms Insertion loss: .05 freq GHz Shielding effectiveness: min. 125 dB 3rd order IM product, typical -125 dBm (-168 dBc)

MECHANICAL

Mating	MIL-Std. 348
Inner attachment method	Solder or captivated
Outer attachment method	Compression
Assembly torque	18/22 lb-ft (25/30 N-m)
Coupling torque	15.00 lb-in (1.70 N-m)
Coupling nut retention force	100.00 lbs (444.80 N)
Connector durability	500 cycles, 12 cycles/min

MATERIAL

Body	Brass, silver plated
Contacts	Outer: Brass, silver plated Inner: BeCu, gold plated
Other metal parts	Brass: silver plated
Insulators	TFE
Gaskets	Silicone rubber

ENVIRONMENTAL

Temperature range	Operating: -40°C to +150°C Storage: -70°C to +100°C
Thermal Shock	MIL-Std. 202 method 107 (test cond. A-1)
Immersion	IEC 529, IP68
Vibration	MIL-Std. 202 method 204 (test cond. B)
Corrosion	MIL-Std. 202 method 101 (test cond. B)
Mechanical Shock	MIL-Std. 202 method 213 (test cond. I)

* These characteristics are typical and may not apply to all connectors.

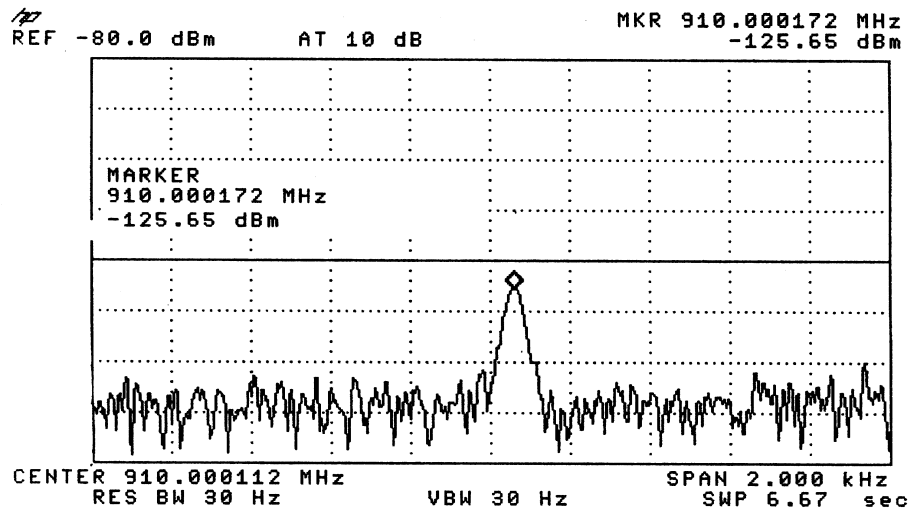

S
Corrugated Cable

S=Superflex (helical)
A=Annular

1
Cable Diameter

1=1/4"
2=3/8"
4=1/2"
5=7/8"
6=1-1/4"
7=1-5/8"

W
Plating

W=White Bronze
P=Plated Body
(none)=Unplated

N
Interface

N=Type N

M
Gender

M=Male (plug)
F=Female (jack)
R=Right Angle
Male (plug)

PM
Options

PM=Panel Mount
PM-SO=Panel Mount-
Slotted Outer
U=Universal

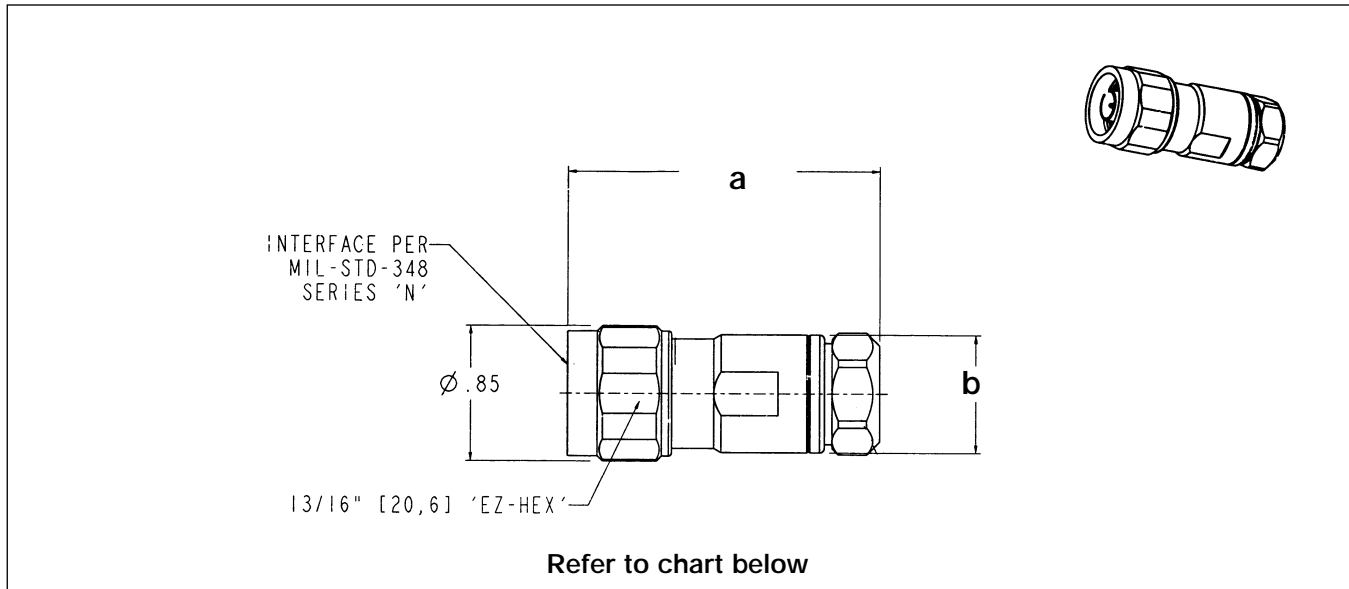

N PLUG INTERFACE — STRAIGHT

Cable	Inner Attachment	a	b	Body	Contact	Amphenol Number
1/4" Helical	Solderless	1.97	.74	White Bronze	Gold	S1WNM
1/4" Helical	Solder	1.97	.74	Silver	Gold	S1PNM-S
3/8" Helical	Solderless	2.437	.875	White Bronze	Gold	S2WNM
3/8" Helical	Solder	2.437	.875	Silver	Gold	S2PNM-S
3/8" Helical	Solderless	2.437	.875	Silver	Gold	S2WNM-SO
1/2" Helical	Solderless	2.46	.950	White Bronze	Gold	S4WNM-U
1/2" Helical	Solder	2.46	.950	White Bronze	Gold	S4WNM-SU
1/2" Helical	Solder	2.46	.950	Unplated	Silver	S4NM-S
1/2" Annular	Solderless	2.81	1.025	Silver	Gold	A4PNM
1/2" Annular	Solder	2.81	1.03	Silver	Gold	A4PNM-S
1/2" Annular	Solder	2.81	1.03	Unplated	Silver	A4NM-S
1/2" Annular	Solderless	2.81	1.025	Unplated	Silver	A4NM
7/8" Annular	Solderless	2.99	1.62	Silver	Silver	A5PNM
7/8" Annular	Solderless	2.99	1.62	Unplated	Silver	A5NM

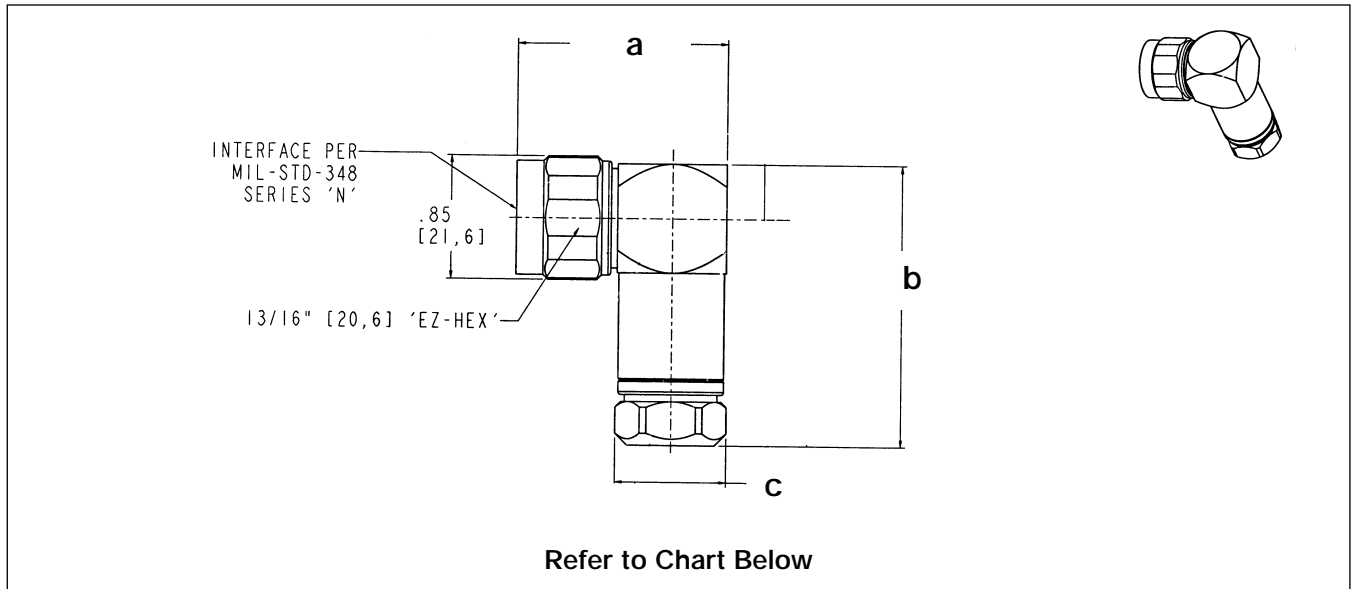

N PLUG INTERFACE — RIGHT ANGLE

Cable	Inner Attachment	a	b	c	Body	Contact	Amphenol Number
1/4" Helical	Solderless	1.45	1.94	.76	White Bronze	Gold	S1PNR
3/8" Helical	Solderless	1.679	2.30	.875	White Bronze	Gold	S2PNR-SO
1/2" Helical	Solder	1.74	1.91	.94	White Bronze	Gold	S4PNR-S
1/2" Helical	Solderless	1.74	2.26	.94	White Bronze	Gold	S4PNR
1/2" Annular	Solderless	1.80	2.53	1.00	White Bronze	Gold	A4PNR

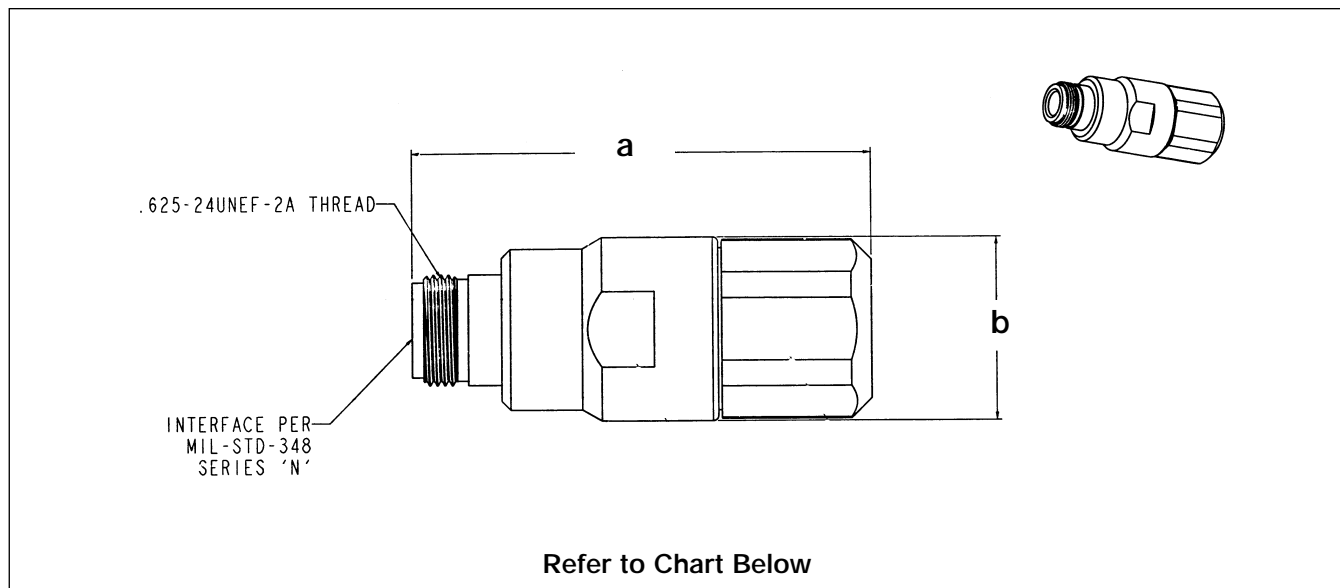

N JACK INTERFACE — STRAIGHT

Cable	Inner Attachment	a	b	Body	Contact	Amphenol Number
1/4" Helical	Solderless	1.87	.74	White Bronze	Gold	S1WNF
1/2" Helical	Solderless	2.36	.95	White Bronze	Gold	S4WNF-U
1/2" Helical	Solder	2.36	.95	Silver	Gold	S4PNF-S
1/2" Helical	Solder	2.36	.95	Unplated	Silver	S4NF-S
1/2" Annular	Solderless	2.56	1.03	White Bronze	Gold	A4WNF
1/2" Annular	Solder	2.56	1.03	Silver	Gold	A4PNF-S
1/2" Annular	Solder	2.56	1.03	Unplated	Silver	A4NF-S
1/2" Annular	Solderless	2.56	1.03	Unplated	Silver	A4NF
7/8" Annular	Solderless	2.64	1.62	Unplated	Silver	A5NF
7/8" Annular	Solderless	2.64	1.62	White Bronze	Gold	A5WNF
1 1/4" Annular	Solderless	3.81	1.87	White Bronze	Gold	A6WNF
1 1/4" Annular	Solderless	3.81	1.87	Silver	Gold	A6PNF-H
1 1/4" Annular	Solderless	3.81	1.87	Unplated	Silver	A6NF
1 1/4" Annular	Solderless	3.81	1.87	Unplated	Silver	A6NF-H
1 5/8" Annular	Solderless	4.26	2.36	White Bronze	Gold	A7WNF
1 5/8" Annular	Solderless	4.26	2.36	Unplated	Silver	A7NF-1

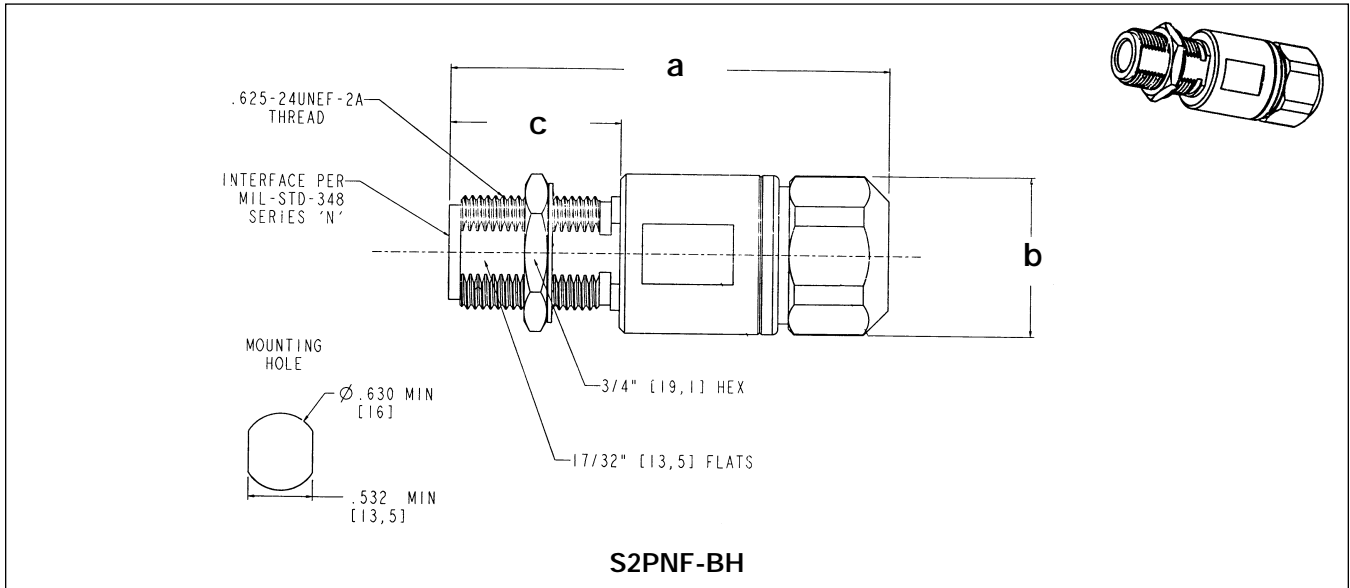

N JACK BULKHEAD MOUNT

Cable	Inner Attachment	a	b	c	Body	Contact	Amphenol Number
3/8" Helical	Solderless	2.42	.88	.94	Silver	Gold	S2PNF-BH