

**TENTATIVE TOSHIBA HYBRID DIGITAL INTEGRATED CIRCUIT
134,217,728-WORD BY 16-BIT (256M Bytes) Direct Rambus DRAM MODULE**

DESCRIPTION

The THMR1N16E is a 134,217,728-word by 16-bit direct rambus dynamic RAM module consisting of 8 TC59RM716MB and 8 TC59RM716RB Direct Rambus DRAMs on a printed circuit board.

FEATURES

	-6	-7	-8
Organization	128M-word ×16 bit	128M-word ×16 bit	128M-word ×16 bit
I/O Frequency	600MHz	711MHz	800MHz
t _{RAC} (Row Access time)	53ns	45ns	45ns
Part Designator	128M (×16) -16CSP	128M (×16) -16CSP	128M (×16) -16CSP

- Power supply of 2.5V (±5%)
- 256MB Direct RDRAM storage
- Each RDRAM has 32 banks for 512 banks total on module
- Separate Row and Column buses for higher efficiency
- Package: 184pin DIMM
- Gold contacts
- Serial Presence Detect support

PIN ASSIGNMENT (TOP VIEW)

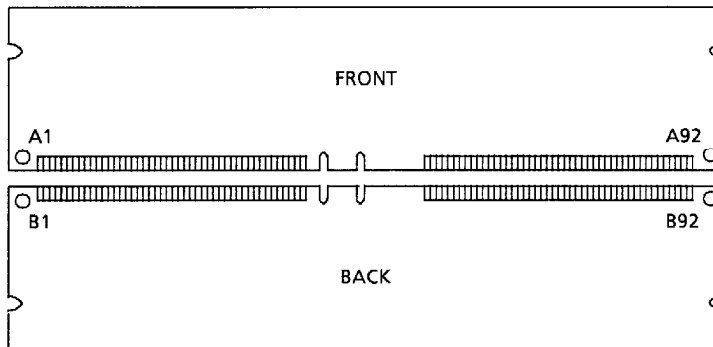

A1	Gnd	B1	Gnd	A24	LCOL0	B24	LDQB0	A47	NC	B47	NC	A70	Gnd	B70	Gnd
A2	LDQA8	B2	LDQA7	A25	Gnd	B25	Gnd	A48	NC	B48	NC	A71	RCOL2	B71	RCOL1
A3	Gnd	B3	Gnd	A26	LDQB1	B26	LDQB2	A49	NC	B49	NC	A72	Gnd	B72	Gnd
A4	LDQA6	B4	LDQA5	A27	Gnd	B27	Gnd	A50	NC	B50	NC	A73	RCOL4	B73	RCOL3
A5	Gnd	B5	Gnd	A28	LDQB3	B28	LDQB4	A51	Vref	B51	Vref	A74	Gnd	B74	Gnd
A6	LDQA4	B6	LDQA3	A29	Gnd	B29	Gnd	A52	Gnd	B52	Gnd	A75	RROW1	B75	RROW0
A7	Gnd	B7	Gnd	A30	LDQB5	B30	LDQB6	A53	SCL	B53	SA0	A76	Gnd	B76	Gnd
A8	LDQA2	B8	LDQA1	A31	Gnd	B31	Gnd	A54	Vdd	B54	Vdd	A77	NC	B77	RROW2
A9	Gnd	B9	Gnd	A32	LDQB7	B32	LDQB8	A55	SDA	B55	SA1	A78	Gnd	B78	Gnd
A10	LDQA0	B10	LCFM	A33	Gnd	B33	Gnd	A56	SVdd	B56	SVdd	A79	RCTM	B79	NC
A11	Gnd	B11	Gnd	A34	L5CK	B34	LCMD	A57	SWP	B57	SA2	A80	Gnd	B80	Gnd
A12	LCTMN	B12	LCFMN	A35	Vcmos	B35	Vcmos	A58	Vdd	B58	Vdd	A81	RCTMN	B81	RCFMN
A13	Gnd	B13	Gnd	A36	SOUT	B36	SIN	A59	RSCK	B59	RCMD	A82	Gnd	B82	Gnd
A14	LCTM	B14	NC	A37	Vcmos	B37	Vcmos	A60	Gnd	B60	Gnd	A83	RDOA0	B83	RCFM
A15	Gnd	B15	Gnd	A38	NC	B38	NC	A61	RDOB7	B61	RDOB8	A84	Gnd	B84	Gnd
A16	NC	B16	LROW2	A39	Gnd	B39	Gnd	A62	Gnd	B62	Gnd	A85	RDOA2	B85	RDOA1
A17	Gnd	B17	Gnd	A40	NC	B40	NC	A63	RDOB5	B63	RDOB6	A86	Gnd	B86	Gnd
A18	LROW1	B18	LROWn	A41	Vdd	B41	Vdd	A64	Gnd	B64	Gnd	A87	RDOA4	B87	RDOA3
A19	Gnd	B19	Gnd	A42	Vdd	B42	Vdd	A65	RDOB3	B65	RDOB4	A88	Gnd	B88	Gnd
A20	LCOL4	B20	LCOL3	A43	NC	B43	NC	A66	Gnd	B66	Gnd	A89	RDOA6	B89	RDOA5
A21	Gnd	B21	Gnd	A44	NC	B44	NC	A67	RDOB1	B67	RDOB2	A90	Gnd	B90	Gnd
A22	LCOL2	B22	LCOL1	A45	NC	B45	NC	A68	Gnd	B68	Gnd	A91	RDOA8	B91	RDOA7
A23	Gnd	B23	Gnd	A46	NC	B46	NC	A69	RCOL0	B69	RDOB0	A92	Gnd	B92	Gnd

000707EBA1

- TOSHIBA is continually working to improve the quality and reliability of its products. Nevertheless, semiconductor devices in general can malfunction or fail due to their inherent electrical sensitivity and vulnerability to physical stress. It is the responsibility of the buyer, when utilizing TOSHIBA products, to comply with the standards of safety in making a safe design for the entire system, and to avoid situations in which a malfunction or failure of such TOSHIBA products could cause loss of human life, bodily injury or damage to property. In developing your designs, please ensure that TOSHIBA products are used within specified operating ranges as set forth in the most recent TOSHIBA products specifications. Also, please keep in mind the precautions and conditions set forth in the "Handling Guide for Semiconductor Devices," or "TOSHIBA Semiconductor Reliability Handbook" etc..
- The TOSHIBA products listed in this document are intended for usage in general electronics applications (computer, personal equipment, office equipment, measuring equipment, industrial robotics, domestic appliances, etc.). These TOSHIBA products are neither intended nor warranted for usage in equipment that requires extraordinarily high quality and/or reliability or a malfunction or failure of which may cause loss of human life or bodily injury ("Unintended Usage"). Unintended Usage include atomic energy control instruments, airplane or spaceship instruments, transportation instruments, traffic signal instruments, combustion control instruments, medical instruments, all types of safety devices, etc.. Unintended Usage of TOSHIBA products listed in this document shall be made at the customer's own risk.
- The products described in this document are subject to the foreign exchange and foreign trade laws.
- The information contained herein is presented only as a guide for the applications of our products. No responsibility is assumed by TOSHIBA CORPORATION for any infringements of intellectual property or other rights of the third parties which may result from its use. No license is granted by implication or otherwise under any intellectual property or other rights of TOSHIBA CORPORATION or others.
- The information contained herein is subject to change without notice.

PIN NAMES

Signal	I/O	Type	Description	Pins
SIN	I/O	CMOS	Serial I/O. Pin for reading from and writing to the control registers.	B36
SOUT	I/O	CMOS	Serial I/O. Pin for reading from and writing to the control registers.	A36
VDD			Supply voltage for the RDRAM core and interface logic.	A41, B41, A42, B42, A54, B54, A58, B58
GND			Ground reference for RDRAM core and interface.	A1, B1, A3, B3, A5, B5, A7, B7, A9, B9, A11, B11, A13, B13, A15, B15, A17, B17, A19, B19, A21, B21, A23, B23, A25, B25, A27, B27, A29, B29, A31, B31, A33, B33, A39, B39, A52, B52, A60, B60, A62, B62, A64, B64, A66, B66, A68, B68, A70, B70, A72, B72, A74, B74, A76, B76, A77, B78, B78, A80, B80, A82, B82, A84, B84, A86, B86, A88, B88, A90, B90, A92, B92
LDQA7 to 0	I/O	RSL	Data bus A. A 8-pin bus carrying a byte of read or write data between the Channel and the RDRAM.	B2, A4, B4, A6, B6, A8, B8, A10
LCFM	I	RSL	Clock from master. Interface clock used for receiving RSL signals from the Channel. Positive polarity.	B10
LCFMN	I	RSL	Clock from master. Interface clock used for receiving RSL signals from the Channel. Negative polarity.	B12
	VREF		Logic threshold reference voltage for RSL signals.	A51, B51
LCTMN	I	RSL	Clock to master. Interface clock used for transmitting RSL signals to the Channel. Negative polarity.	A12
LCTM	I	RSL	Clock to master. Interface clock used for transmitting RSL signals to the Channel. Positive polarity.	A14
LROW2 to 0	I	RSL	Row bus. 3-pin bus containing control and address information for row accesses.	B16, A18, B18
LCOL4 to 0	I	RSL	Column bus. 5-pin bus containing control and address information for column accesses.	A20, B20, A22, B22, A24
LDQB7 to 0	I/O	RSL	Data bus B. A 8-bit bus carrying a byte of read or write data between the Channel and the RDRAM.	A32, B30, A30, B28, A28, B26, A26, B24
LCMD	I	CMOS	Serial Command Pin. Pin used to read from and write to the control registers. Also used for power management.	B34
LSCK	I	CMOS	Clock input. Pin used to read from and write to the control registers.	A34
RDQA7 to 0	I/O	RSL	Data bus A. A 8-pin bus carrying a byte of read or write data between the Channel and the RDRAM.	B91, A89, B89, A87, B87, A85, B85, A83
RCFM	I	RSL	Clock from master. Interface clock used for receiving RSL signals from the Channel. Positive polarity.	B83
RCFMN	I	RSL	Clock from master. Interface clock used for receiving RSL signals from the Channel. Negative polarity.	B81
RCTM	I	RSL	Clock to master. Interface clock used for transmitting RSL signals to the Channel. Positive polarity.	A79
RROW2 to 0	I	RSL	Row bus. 3-pin bus containing control and address information for row accesses.	B77, A75, B75
RCOL4 to 0	I	RSL	Column bus. 5-pin bus containing control and address information for column accesses.	A73, B73, A71, B71, A69
RDQB7 to 0	I/O	RSL	Data bus B. A 8-bit bus carrying a byte of read or write data between the Channel and the RDRAM.	A61, B63, A63, B65, A65, B67, A67, B69
RCMD	I	CMOS	Serial Command Input. Pin used to read from and write to the control registers. Also used for power management.	B59
RSCK	I	CMOS	Clock input. Pin used to read from and write to the control registers.	A59
SCL	I	CMOS	Serial Presence Detect Clock.	A53
SDA	I/O	CMOS	Serial Presence Detect Data (Open Collector I/O).	A55
SA0	I	CMOS	Serial Presence Detect Address 0.	B53
SA1	I	CMOS	Serial Presence Detect Address 1.	B55
SA2	I	CMOS	Serial Presence Detect Address 2.	B57
SWP	I	CMOS		A57
VCMOS			Termination Voltage.	A37, B37, A35, B35
SVDD			Supply voltage for the E ² PROM (SPD).	A56, B56
N.C.				B14, A16, A38, B38, A40, B40, A43, B43, A44, B44, A45, B45, A46, B46, A47, B47, A48, B48, A49, B49, A50, B50, B79,

SERIAL PRESENCE DETECT

Byte Number	Function	THMR1N16E-6		THMR1N16E-7		THMR1N16E-8	
		128Mx16 (256MB), 600MHz-53ns		128Mx16 (256MB), 711MHz-45ns		128Mx16 (256MB), 800MHz-45ns	
		Entry Value	Entry	Entry Value	Entry	Entry Value	Entry
0	SPD revision level	1.0	02 h	1.0	02 h	1.0	02 h
1	Total number of bytes in the SPD	256 bytes	08 h	256 bytes	08 h	256 bytes	08 h
2	Device type	DRDRAM	01 h	DRDRAM	01 h	DRDRAM	01 h
3	Module type	RIMM	01 h	RIMM	01 h	RIMM	01 h
4	Row address bit, Column address bit	9.6	96 h	9.6	96 h	9.6	96 h
5	Bank address bits and byte	32 s	C5 h	32 s	C5 h	32 s	C5 h
6	Refresh bank bit	5	05 h	5	05 h	5	05 h
7	tREF-Refresh interval	32	20 h	32	20 h	32	20 h
8	Protocol version	2	02 h	2	02 h	2	02 h
9	Miscellaneous device configuration field (Low Power/no Low Power)	1.5 tSCK S28IECO	05 h	1.5 tSCK S28IECO	05 h	1.5 tSCK S28IECO	05 h
10	tRP-R, Min	8 Cycle	08 h	8 Cycle	08 h	8 Cycle	08 h
11	tRAS-R, Min	20 Cycle	14 h	20 Cycle	14 h	20 Cycle	14 h
12	tRCD-R, Min	8 Cycle	08 h	8 Cycle	08 h	10 Cycle	0A h
13	tRR-R, Min	8 Cycle	08 h	8 Cycle	08 h	8 Cycle	08 h
14	tPP-R, Min	8 Cycle	08 h	8 Cycle	08 h	8 Cycle	08 h
15	Min tCYCLE for range A	3.33 ns	1A h	2.67 ns	15 h	2.43 ns	13 h
16	Max tCYCLE for range A	3.71 ns	1E h	3.71 ns	1E h	3.45 ns	1E h
17	tCDLY range for A	4 - 9	49 h	5 - 9	59 h	5 - 9	59 h
18	tCLS and tCAS range for A	tCLS = 2, tCAS = 2	AA h	tCLS = 2, tCAS = 2	AA h	tCLS = 2, tCAS = 2	AA h
19	Min tCYCLE for range B	—	00 h	3.33 ns	1A h	3.33 ns	1A h
20	Max tCYCLE for range B	—	00 h	3.71 ns	1E h	3.71 ns	1E h
21	tCDLY range for range B	—	00 h	4 - 9	49 h	4 - 9	49 h
22	tCLS and tCAS range for range B	—	00 h	tCLS = 2, tCAS = 2	AA h	tCLS = 2, tCAS = 2	AA h
23	Min tCYCLE range for C	—	00 h	—	00 h	—	00 h
24	Max tCYCLE for range C	—	00 h	—	00 h	—	00 h
25	tCDLY range for range C	—	00 h	—	00 h	—	00 h
26	tCLS and tCAS range for range C	—	00 h	—	00 h	—	00 h
27	Min tCYCLE for range D	—	00 h	—	00 h	—	00 h
28	Max tCYCLE for range D	—	00 h	—	00 h	—	00 h
29	tCDLY range for range D	—	00 h	—	00 h	—	00 h
30	tCLS and tCAS range for range D	—	00 h	—	00 h	—	00 h
31	tPDNXA, Min	4 us	04 h	4 us	04 h	4 us	04 h
32	tPDNXA, Max	9000 Cycles	8D h	9000 Cycles	8D h	9000 Cycles	8D h
33	tNAPXA, Min	50 ns	32 h	50 ns	32 h	50 ns	32 h
34	tNAPXB, Min	40 ns	28 h	40 ns	28 h	40 ns	28 h
35	fIMIN [11:8], fIMAX [11:8]	261,300MHz	11 h	261,357MHz	11 h	261,400MHz	11 h
36	fIMIN [7:0]	261MHz	05 h	261MHz	05 h	261MHz	05 h
37	fIMAX [7:0]	300MHz	2C h	357MHz	65 h	400MHz	90 h
38	ODF Mapping	12.5%	01 h	12.5%	01 h	12.5%	01 h
39	tCTRL, MAX	100 ms	64 h	100 ms	64 h	100 ms	64 h
40	tTEMP, MAX	100 ms	64 h	100 ms	64 h	100 ms	64 h
41	tTCEN, MIN	150 tCYCLE	96 h	150 tCYCLE	96 h	150 tCYCLE	96 h
42	tRAS-R, MAX	64 us	40 h	64 us	40 h	64us	40 h
43	tNLIMIT, MAX	10 us	0A h	10 us	0A h	10us	0A h
44	ACTREFPT, PCHRERPT	6.6 tCYCLE	66 h	6.6 tCYCLE	66 h	6.6 tCYCLE	66 h
45	CPCHREFPT_DC, RDREFPT_DC	5.5 tCYCLE	55 h	5.5 tCYCLE	55 h	5.5 tCYCLE	55 h
46	RETREFPT_DC, WRREFPT_DC	5.13 tCYCLE	5D h	5.13 tCYCLE	5D h	5.13 tCYCLE	5D h
47-49	Reserved		00 h		00 h		00 h
50	fRAS [11:8]	300MHz	01 h	357MHz	01 h	400MHz	01 h
51	fRAS [7:0]	300MHz	2C h	357MHz	65 h	400MHz	90 h
52	PMAX, HI, PMAX, LO, TJ	0,0,100degC	24 h	0,0,100degC	24 h	0,0,100degC	24 h
53	Heat Spreader, Tplate	1.90degC	9A h	1.90degC	9A h	1.90degC	9A h

Byte Number	Function	THMR1N16E-6		THMR1N16E-7		THMR1N16E-8	
		128Mx16 (256MB), 600MHz-53ns		128Mx16 (256MB), 711MHz-45ns		128Mx16 (256MB), 800MHz-45ns	
		Entry Value	Entry	Entry Value	Entry	Entry Value	Entry
54	PSTBY, HI	90mA	5Ah	95mA	5Fh	105mA	69h
55	PACTI, HI	125mA	3Fh	140mA	46h	150mA	48h
56	PACTI KW, HI	455mA	39h	520mA	41h	575mA	48h
57	PSTBY, LO	85mA	55h	85mA	55h	85mA	55h
58	PACTI, LO	115mA	3Ah	115mA	3Ah	115mA	3Ah
59	PACTRW, LO	415mA	34h	415mA	34h	415mA	34h
60	PNAP	4.2mA	21h	4.2mA	21h	4.2mA	21h
61	PRESA		00h		00h		00h
62	PRESB		00h		00h		00h
63	Checksum for location 0-62		81h		3Dh		A9h
64		TOSHIBA	98h	TOSHIBA	98h	TOSHIBA	98h
65-71			00h		00h		00h
72	Module manufacturing location						
73-90	Module part number						
91-92	Module revision code		00h		00h		00h
93	Module manufacturing year						
94	Module manufacturing week						
95-98	Module serial number						
99	Number of devices on module	16	10h	16	10h	16	10h
100	Module data width	16	10h	16	10h	16	10h
101	Device enables	All 16device enabled	FFh	All 16device enabled	FFh	All 16device enabled	FFh
102			FFh		FFh		FFh
103			00h		00h		00h
104			00h		00h		00h
105	Module Vdd, Module Voltage Interface level	2.5V,1.8V	10h	2.5V,1.8V	10h	2.5V,1.8V	10h
106	Module VDD tolerance	5% DC 2% AC	52h	5% DC 2% AC	52h	5% DC 2% AC	52h
107-113	Reserved		00h		00h		00h
114	CDLY0/1 for tCDLY = 3	-	00h	-	00h	-	00h
115	CDLY0/1 for tCDLY = 4	2 / 0	20h	2 / 0	20h	2 / 0	20h
116	CDLY0/1 for tCDLY = 5	3 / 0	30h	3 / 0	30h	3 / 0	30h
117	CDLY0/1 for tCDLY = 6	3 / 1	31h	3 / 1	31h	3 / 1	31h
118	CDLY0/1 for tCDLY = 7	3 / 2	32h	3 / 2	32h	3 / 2	32h
119	CDLY0/1 for tCDLY = 8	4 / 2	42h	4 / 2	42h	4 / 2	42h
120	CDLY0/1 for tCDLY = 9	5 / 2	52h	5 / 2	52h	5 / 2	52h
121	CDLY0/1 for tCDLY = 10	-	00h	-	00h	-	00h
122	CDLY0/1 for tCDLY = 11	-	00h	-	00h	-	00h
123	CDLY0/1 for tCDLY = 12	-	00h	-	00h	-	00h
124	CDLY0/1 for tCDLY = 13	-	00h	-	00h	-	00h
125	CDLY0/1 for tCDLY = 14	-	00h	-	00h	-	00h
126	CDLY0/1 for tCDLY = 15	-	00h	-	00h	-	00h
127	Checksum for location 99-126		C7h		C7h		C7h

BLOCK DIAGRAM

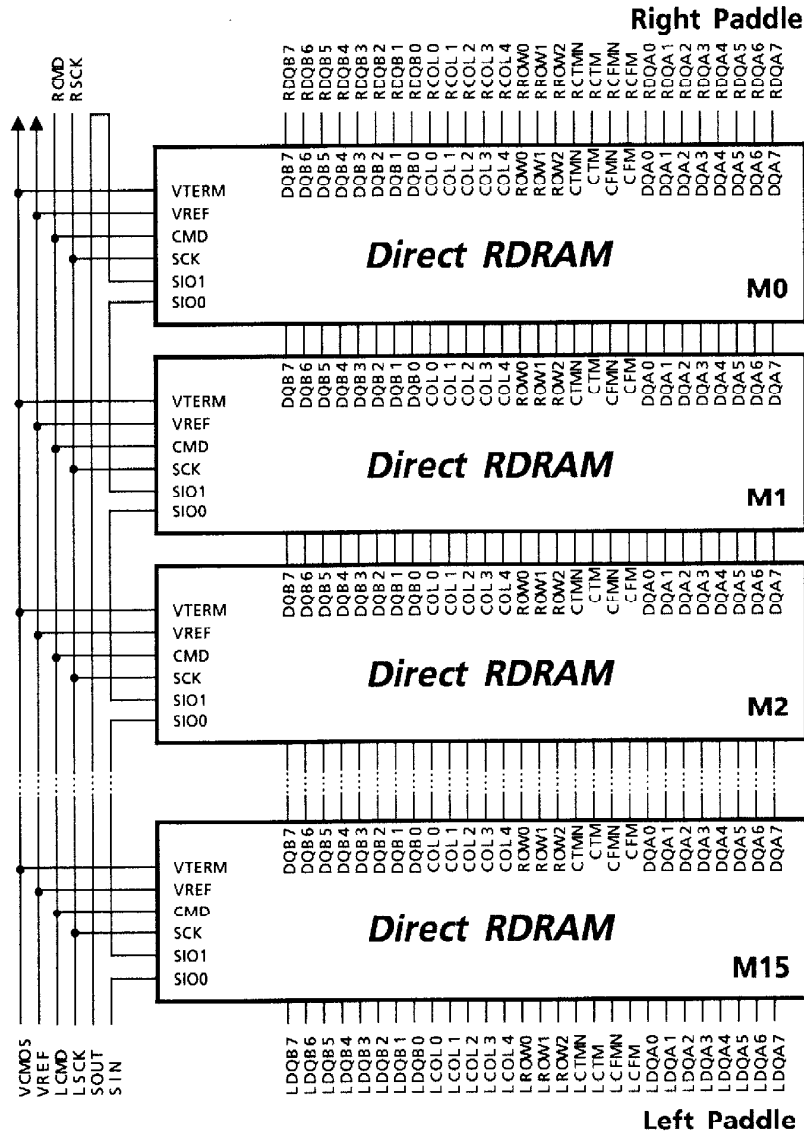

<M0-15>

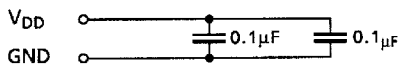

<M0-15>

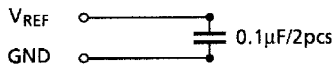

<M0-15>

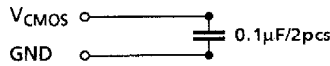

<E2PROM>

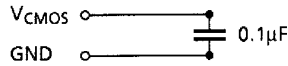

Serial Presence Detect

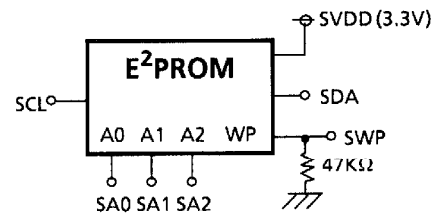

ABSOLUTE MAXIMUM RATINGS

SYMBOL	PARAMETER	MIN	MAX	UNIT
$V_{I, ABS}$	Voltage applied to any RSL pin with respect to Gnd	-0.3	$V_{DD} + 0.3$	V
$V_{I, CMOS, ABS}$	Voltage applied to any CMOS pin with respect to Gnd	-0.3	$V_{DD} + 0.3$	V
$V_{DD, ABS}$	Voltage on VDD with respect to Gnd	-0.5	$V_{DD} + 1.0$	V
T_{STORE}	Storage temperature	-50	100	°C

THERMAL PARAMETERS

SYMBOL	PARAMETER and CONDITIONS	MIN	MAX	UNIT
T_J	Junction operating temperature	0	100	°C
θ_{JA}	Junction-to-Ambient thermal resistance		T.B.D.	°C/Watt

RIMM MODULE CURRENT PROFILE

I_{DD}	RIMM module power conditions ^a	MAX	UNIT
I_{DD1}	One RDRAM in Read ^b , balance in NAP mode	630	mA
I_{DD2}	One RDRAM in Read ^b , balance in Standby mode	2082	mA
I_{DD3}	One RDRAM in Read ^b , balance in Active mode	2787	mA
I_{DD4}	One RDRAM in Write, balance in NAP mode	638	mA
I_{DD5}	One RDRAM in Write, balance in Standby mode	2090	mA
I_{DD6}	One RDRAM in Write, balance in Active mode	2795	mA

- a. Actual power will depend on individual RDRAM component specifications, memory controller and usage patterns. Power does not include Refresh Current. Max current computed for x16 128Mb RDRAMs. x18 144Mb RDRAMs use 8mA current per RDRAM in Read and 60mA more current per RDRAM in Write.
- b. I/O current is a function of the % of 1's, to add I/O power for 50% 1's for a X16 need to add 257mA or 290mA for X18 ECC module for the following: $V_{DD} = 2.5V$, $V_{TERM} = 1.8V$, $V_{REF} = 1.4V$ and $V_{DIL} = V_{REF} - 0.5V$.

RECOMMENDED CONDITIONS

SYMBOL	PARAMETER and CONDITIONS	MIN	MAX	UNIT
V_{DD}	Supply Voltage	2.50-0.13	2.50 + 0.13	V
V_{CMOS}	CMOS I/O power supply at pad for 2.5V controllers:	2.5 - 0.13	2.5 + 0.25	V
	CMOS I/O power supply at pad for 1.8V controllers:	1.8 - 0.1	1.8 + 0.2	V
V_T	Termination Voltage	1.80-0.1	1.80 + 0.1	V
V_{REF}	Reference Voltage	1.40-0.1	1.40 + 0.2	V
V_{IL}	RSL input low Voltage	$V_{REF} - 0.5$	$V_{REF} - 0.2$	V
V_{IH}	RSL input high Voltage	$V_{REF} + 0.2$	$V_{REF} + 0.5$	V
$V_{IL, CMOS}$	CMOS input low Voltage	-0.3	$0.5V_{CMOS} - 0.25$	V
$V_{IH, CMOS}$	CMOS input high Voltage	$0.5V_{CMOS} + 0.25$	$V_{CMOS} + 0.3$	V
SV_{DD}	SPD power supply	2.5	3.6	V
V_{SIL}	SPD input low Voltage	-0.3	$SV_{DD} \times 0.3$	V
V_{SIH}	SPD input high Voltage	$SV_{DD} \times 0.7$	$SV_{DD} + 0.3$	V

ELECTRICAL CHARACTERISTICS

SYMBOL	PARAMETER and CONDITIONS	MIN	MAX	UNIT
I_{REF}	VREF current @ $V_{REF, MAX}$	-160	160	μA
$I_{SCK, CMD}$	CMOS input leakage current @ ($0 \leq V_{CMOS} \leq V_{DD}$)	-160	160	μA
$I_{SIN, SOUT}$	CMOS input leakage current @ ($0 \leq V_{CMOS} \leq V_{DD}$)	-10	10	μA
$V_{OL, CMOS}$	CMOS output Voltage @ $I_{OL, CMOS} = 1.0mA$	-	0.3	V
$V_{OH, CMOS}$	CMOS output high Voltage @ $I_{OH, CMOS} = -0.25mA$	$V_{CMOS} - 0.3$	-	V
V_{SOL}	SPD output low Voltage ($I_{SOL} = 3mA$)		0.4	V

- a. Z_{OUT} is the load on the output used for CAL/SAM calibration ; output pin under test is unloaded.
 $V_{TERM} = 1.8V$ and $V_{REF} = 1.4V$.

TIMING CHARACTERISTICS

SYMBOL	PARAMETER	MIN	MAX	UNIT
t_Q	CTM-to-DQA/DQB output time @ $t_{CYCLE} = 3.33ns$	-0.350 ^{a,c}	+ 0.350 ^{a,c}	ns
	CTM-to-DQA/DQB output time @ $t_{CYCLE} = 2.81ns$	-0.300 ^{b,c}	+ 0.300 ^{b,c}	ns
	CTM-to-DQA/DQB output time @ $t_{CYCLE} = 2.50ns$	-0.260 ^c	+ 0.260 ^c	ns
t_{QR}, t_{QF}	DQA/DQB output rise and fall times	0.2	0.45	ns
t_{Q1}	SCK(neg)-to-SIO0 delay @ $C_{LOAD,MAX} = 20pF$ (SD read data valid).	-	10	ns
t_{HR}	SCK(pos)-to-SIO0 delay @ $C_{LOAD,MAX} = 20pF$ (SD read data hold).	2	-	ns
t_{OR1}, t_{OF1}	SIO _{OUT} rise/fall @ $C_{LOAD,MAX} = 20pF$	-	5	ns
t_{PROP1}	SIO0-to-SIO1 or SIO1-to-SIO0 delay @ $C_{LOAD,MAX} = 20pF$	-	10	ns
t_{NAPXA}	NAP exit delay - phase A	-	50	ns
t_{NAPXB}	NAP exit delay - phase B	-	40	ns
t_{PDNXA}	PDN exit delay - phase A	-	4	μs
t_{PDNXB}	PDN exit delay - phase B	-	9000	t_{CYCLE}
t_{AS}	ATTN-to-STBY power state delay	-	1	t_{CYCLE}
t_{SA}	STBY-to-ATTN power state delay	-	0	t_{CYCLE}
t_{ASN}	ATTN/STBY-to-NAP power state delay	-	8	t_{CYCLE}
t_{ASP}	ATTN/STBY-to-PDN power state delay	-	8	t_{CYCLE}

- a. This parameter also applies to a -800 or -711 part when operated with $t_{CYCLE} = 3.33ns$.
 b. This parameter also applies to a -800 part when operated with $t_{CYCLE} = 2.81ns$.
 c. $t_{Q,MIN}$ and $t_{Q,MAX}$ for other t_{CYCLE} values can be interpolated between or extrapolated from the timings at the 3 specified t_{CYCLE} values.

RECOMMENDED TIMING CONDITIONS

SYMBOL	PARAMETER	MIN	MAX	UNIT	
t _{CR} , t _{CF}	CTM and CFM input rise and fall times	0.2	0.5	ns	
t _{CYCLE}	CTM and CFM cycle times	600	3.33	3.83	ns
		711	2.80	3.83	ns
		800	2.50	3.83	ns
t _{CH} , t _{CL}	CTM and CFM high and low times	40%	60%	t _{CYCLE}	
t _{TR}	CTM-CFM differential	MSE/MS = 0/0	0.0	1.0	t _{CYCLE}
		MSE/MS = 1/1	0.9	1.0	t _{CYCLE}
t _{DR} , t _{DF}	DQA/DQB/ROW/COL input rese/fall times	0.2	0.65	ns	
t _S , t _H	DQA/DQB/ROW/COL-to-CFM set/hold @ t _{CYCLE} = 3.33ns	0.275	-	ns	
	DQA/DQB/ROW/COL-to-CFM set/hold @ t _{CYCLE} = 2.81ns	0.240	-	ns	
	DQA/DQB/ROW/COL-to-CFM set/hold @ t _{CYCLE} = 2.50ns	0.200	-	ns	
t _{DR1} , t _{DF1}	SIO _{IN} ^a , CMD, SCK input rise and fall times	-	5.0	ns	
t _{CYCLE1}	SCK cycle time-Serial control register transactions	1000	-	ns	
	SCK cycle time-Power transitions	10	-	ns	
t _{CH1} , t _{CL1}	SCK high and low times	4.25	-	ns	
t _{S1}	CMD setup time	1	-	ns	
t _{H1}	CMD hold time	1	-	ns	
t _{S2}	SIO _{IN} setup time	40	-	ns	
t _{H2}	SIO _{IN} hold time	40	-	ns	
t _{S3}	PDEV setup time on DQA5..0	0	-	ns	
t _{H3}	PDEV hold time on DQA5..0	5.5	-	ns	
t _{S4}	ROW2..0, COL4..0 setup time for quiet window	-1	-	t _{CYCLE}	
t _{H4}	ROW2..0, COL4..0 hold time for quiet window	5	-	t _{CYCLE}	
t _{CE}	CTM/CFM stable before NAP/PDN exit	2	-	t _{CYCLE}	
t _{CD}	CTM/CFM stable after NAP/PDN entry	100	-	t _{CYCLE}	
t _{FRM}	ROW packet to COL packet ATTN framing delay	7	-	t _{CYCLE}	
t _{NLIMIT}	Maximum time in NAP mode		10.0	μs	
t _{REF}	Refresh interval		32	ms	
t _{RAS}	RAS interval (time a row may stay activated)		64	μs	
t _{PAUSE}	RDRAM substrate bias generator delay		200.0	μs	

a. SIO_{IN} refers to the SIO0 or SIO1 pin when used as an input.

RECOMMENDED TIMING CONDITIONS

SYMBOL	PARAMETER	MIN- -6	MIN- -7	MIN- -8			MAX	UNIT
t_{RC}	Row CYcle time of RDRAM banks-the interval between ROWA packets with ACT commands to the same bank.	28	28	28			-	t_{CYCLE}
t_{RAS}	RAS-asserted time of RDRAM bank-the interval between ROWA packet with ACI command and next ROWR packet with PRER command to the same bank.	20	20	20			-	t_{CYCLE}
t_{RP}	Row Precharge time of RDRAM banks-the interval between ROWR packet with PRER command and next ROWA packet with ACT command to the same bank.	8	8	8			-	t_{CYCLE}
t_{PP}	Precharge-to-precharge time of RDRAM device-the interval between successive ROWR packets with PRER commands to different banks of the same device.	8	8	8			-	t_{CYCLE}
t_{RR}	RAS-to-RAS time of RDRAM device-the interval between successive ROWA packets with ACT commands to different banks of the same device.	8	8	8			-	t_{CYCLE}
t_{RCD}	RAS-to-CAS Delay-the interval from ROWA packet with ACT command to COLC packet with RD or WR command). Note-the RAS-to-CAS delay seen by the RDRAM core ($t_{RCD, CORE}$) is equal to $t_{RCD, CORE} = 1 + t_{RCD}$ because of differences in the row and column paths through the RDRAM interface.	7	7	9			-	t_{CYCLE}
t_{RAC}	RAS Access delay-effective interval from ROWA packet with ACT command to Q read data. This is equal to : $t_{RAC} = 1 + t_{RCD} + t_{CAC}$.	16	18	18			-	t_{CYCLE}
t_{CAC}	CAS Access delay-the minimum interval from RD command to Q read data.	8	8	8			12	t_{CYCLE}
t_{CWD}	CAS Write Delay (interval from WR command to D write data.	6	6	6			6	t_{CYCLE}
t_{CC}	CAS-to-CAS time of RDRAM bank-the interval between successive COLC commands.	4	4	4			-	t_{CYCLE}
t_{PACKET}	Length of ROWA, ROWR, COLC, COLM or COLX packet.	4	4	4			4	t_{CYCLE}
t_{R1R}	Interval from COLC packet with WR command to COLC packet which causes retire, and to optional COLM packet with bytemask.	8	8	8			-	t_{CYCLE}
t_{OFFP}	Interval from last COLC packet with RD or automatic retire command to ROWR packet with PRER. Also, the interval (offset) from COLC packet with RDA command, or from COLC packet with retire command(after WRA automatic precharge), or from COLX packet with PREX command to the equivalent ROWR packet with PRER.	4	4	4				t_{CYCLE}

RSL CLOCKING AND BIT TRANSPORT

Figure 2 shows the timing required to receive or transmit a pair of RSL bits. A single clock cycle T_2 from the central figure is expanded to show the details associated with a falling edge and rising edge of the CFM and CTM clock inputs (the CTFN and CTMN inputs will always be at the opposite signal level). Note that RSL signals are low-true; a high voltage is logic zero.

Figure 2a shows the rise/fall requirements of RSL input signals, and the rise/fall characteristics of RSL output signals.

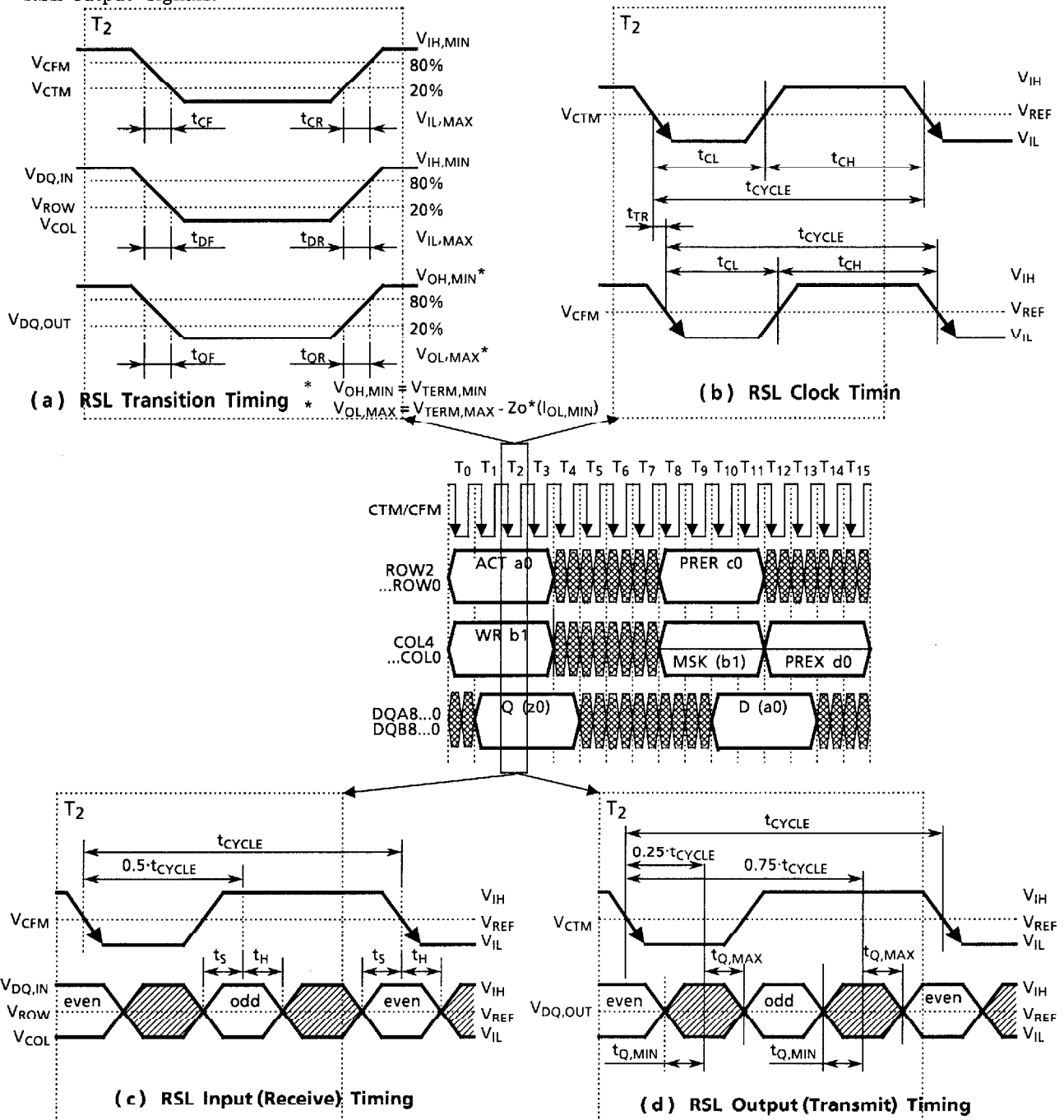

Figure 2: RSL Timing - Clocking and Bit Transport

Figure 2b shows the duty cycle requirements of the RSL clock inputs. It also shows the t_{TR} skew parameter (the amount of time by which CTM may lead CFM).

Figure 2c shows the setup and hold requirements of RSL inputs. Even bits are sampled on the falling edge of CFM and odd bits are sampled at the half-cycle (50%) point. The RDRAM synthesizes the 25%, 50%, and 75% timing points so that two bits may be received or transmitted per clock cycle per signal wire.

Figure 2d shows the valid window of RSL outputs. Even bits are driven from the 75% point and odd bits from the 25% point.

CMOS CLOCKING AND BIT TRANSPORT

Figure 3 shows the timing required to receive or transmit a CMOS bit. A single clock cycle is expanded to show the details associated with a falling edge of the SCK clock input. Note that all CMOS signals are lowtrue; a high voltage is logic zero.

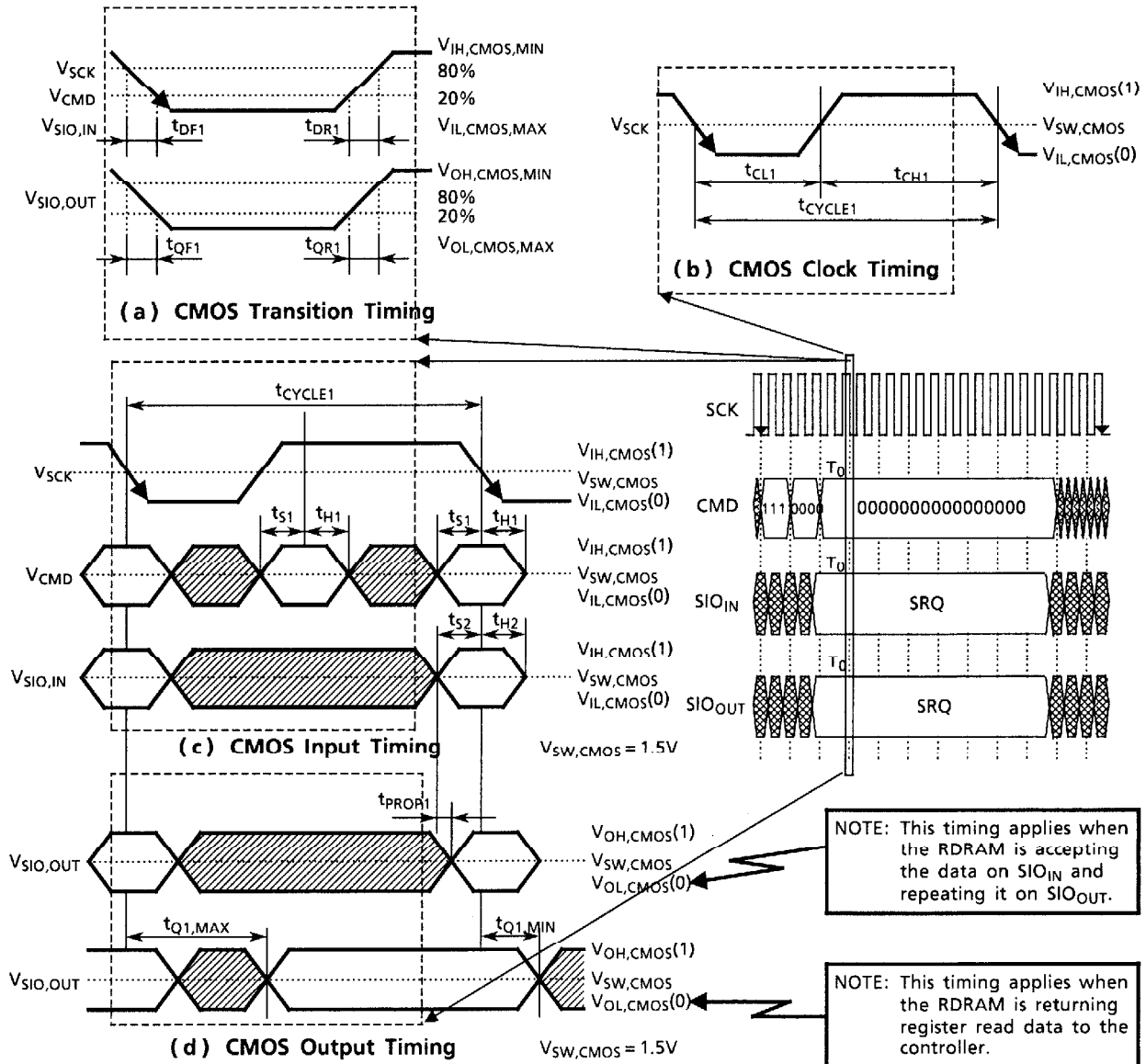
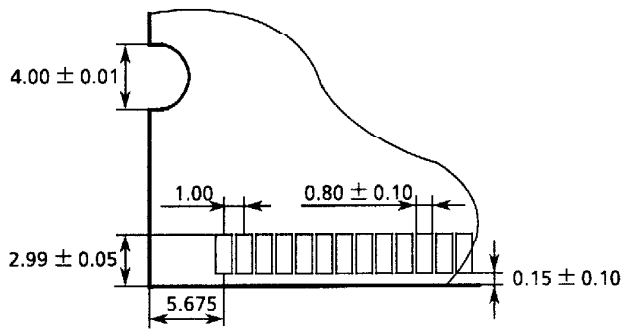
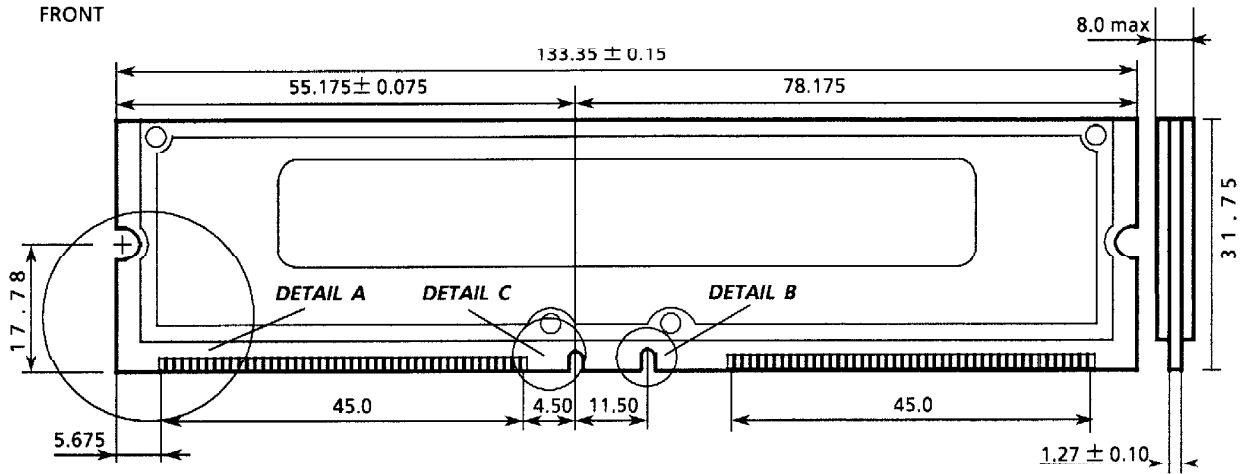

Figure 3: CMOS Timing - Clocking and Bit Transport

PACKAGE DIMENSIONS (THMR1N16E)

Unit: mm

The dimensions without tolerance specification use the default tolerance of ± 0.127 .



DETAIL A

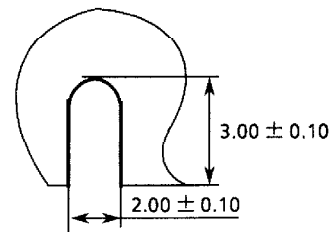

DETAIL B

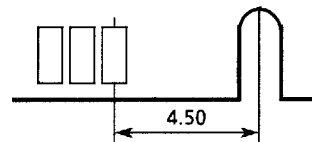

DETAIL C