

74148 Encoder

8-Input Priority Encoder
Product Specification

Logic Products

FEATURES

- Code conversions
- Multi-channel D/A converter
- Decimal-to-BCD converter
- Cascading for priority encoding of "N" bits
- Input Enable capability
- Priority encoding — automatic selection of highest priority input line
- Output Enable — active LOW when all inputs HIGH
- Group Signal output — active when any input is LOW

DESCRIPTION

The '148 8-input priority encoder accepts data from eight active-LOW inputs and provides a binary representation on the three active-LOW outputs. A priority is assigned to each input so that when two or more inputs are simultaneously active, the input with the highest priority is represented on the output, with input line \bar{i}_7 having the highest priority.

TYPE	TYPICAL PROPAGATION DELAY	TYPICAL SUPPLY CURRENT (TOTAL)
74148	10ns	38mA

ORDERING CODE

PACKAGES	COMMERCIAL RANGE $V_{CC} = 5V \pm 5\%$; $T_A = 0^\circ C$ to $+70^\circ C$
Plastic DIP	N74148N
Plastic SO	

NOTES:

For information regarding devices processed to Military Specifications, see the Signetics Military Products Data Manual.

INPUT AND OUTPUT LOADING AND FAN-OUT TABLE

PINS	DESCRIPTION	74
\bar{i}_0	Input	1ul
$\bar{i}_1 - \bar{i}_7$	Inputs	2ul
$\bar{E}1$	Input	2ul
All	Outputs	10ul

NOTE:

A 74 unit load (ul) is understood to be $40\mu A$ I_{IH} and $-1.6mA$ I_{IL} .

PIN CONFIGURATION

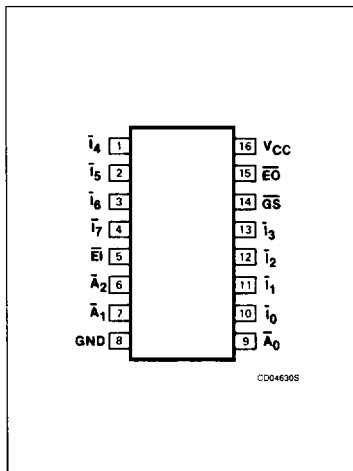

LOGIC SYMBOL

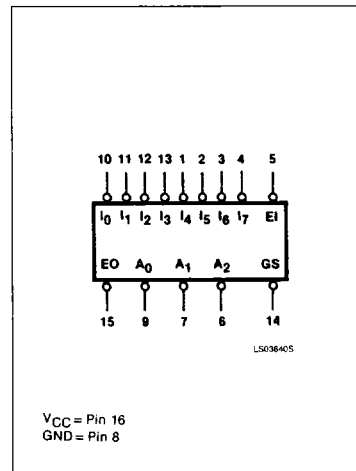

LOGIC SYMBOL (IEEE/IEC)

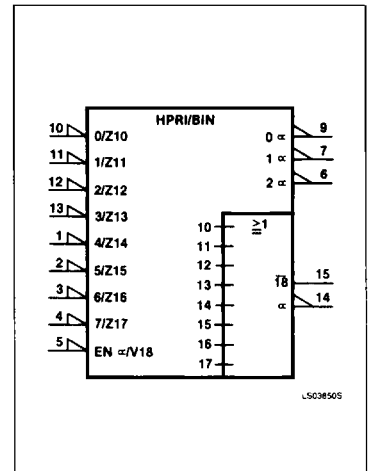

Encoder

74148

A HIGH on the Enable Input (\bar{E}_1) will force all outputs to the inactive (HIGH) state and allow new data to settle without producing erroneous information at the outputs.

A Group Signal (\bar{G}_S) output and an Enable Output (\bar{E}_O) are provided with the three data outputs. The \bar{G}_S is active-LOW when any input is LOW; this indicates when any input is active. The \bar{E}_O is active-LOW when all inputs

are HIGH. Using the Enable Output along with the Enable Input allows priority encoding of N input signals. Both \bar{E}_O and \bar{G}_S are active-HIGH when the Enable input is HIGH.

LOGIC DIAGRAM

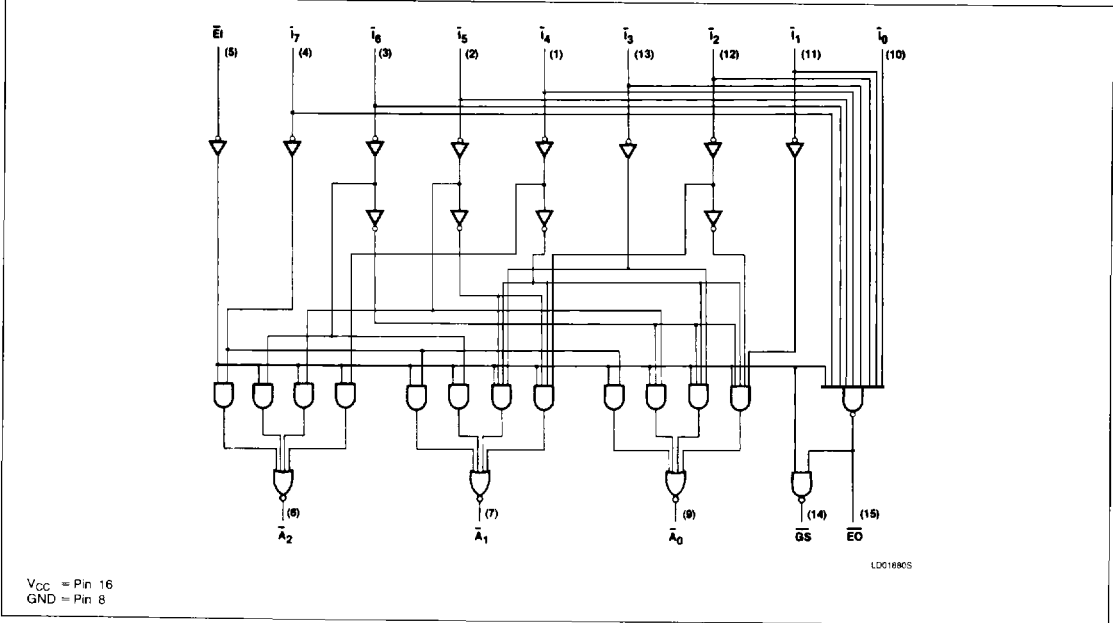

FUNCTION TABLE

INPUTS									OUTPUTS				
\bar{E}_1	\bar{I}_0	\bar{I}_1	\bar{I}_2	\bar{I}_3	\bar{I}_4	\bar{I}_5	\bar{I}_6	\bar{I}_7	\bar{G}_S	\bar{A}_0	\bar{A}_1	\bar{A}_2	\bar{E}_O
H	X	X	X	X	X	X	X	X	H	H	H	H	H
L	H	H	H	H	H	H	H	H	H	H	H	H	L
L	X	X	X	X	X	X	X	L	L	L	L	L	H
L	X	X	X	X	X	L	H	H	L	L	L	L	H
L	X	X	X	L	H	H	H	H	L	L	L	H	H
L	X	X	L	H	H	H	H	H	L	L	L	H	H
L	X	L	H	H	H	H	H	H	L	L	H	H	H
L	L	H	H	H	H	H	H	H	L	H	H	H	H

H = HIGH voltage level
 L = LOW voltage level
 X = Don't care

Encoder

74148

ABSOLUTE MAXIMUM RATINGS (Over operating free-air temperature range unless otherwise noted.)

PARAMETER		74	UNIT
V _{CC}	Supply voltage	7.0	V
V _{IN}	Input voltage	-0.5 to +5.5	V
I _{IN}	Input current	-30 to +5	mA
V _{OUT}	Voltage applied to output in HIGH output state	-0.5 to +V _{CC}	V
T _A	Operating free-air temperature range	0 to 70	°C

RECOMMENDED OPERATING CONDITIONS

PARAMETER		74			UNIT
		Min	Nom	Max	
V _{CC}	Supply voltage	4.75	5.0	5.25	V
V _{IH}	HIGH-level input voltage	2.0			V
V _{IL}	LOW-level input voltage			+0.8	V
I _{IK}	Input clamp current			-12	mA
I _{OH}	HIGH-level output current			-800	μA
I _{OL}	LOW-level output current			16	mA
T _A	Operating free-air temperature	0		70	°C

5

Encoder

74148

DC ELECTRICAL CHARACTERISTICS (Over recommended operating free-air temperature range unless otherwise noted.)

PARAMETER	TEST CONDITIONS ¹	74148			UNIT	
		Min	Typ ²	Max		
V _{OH} HIGH-level output voltage	V _{CC} = MIN, V _{IH} = MIN, V _{IL} = MAX, I _{OH} = MAX	2.4	3.3		V	
V _{OL} LOW-level output voltage	V _{CC} = MIN, V _{IH} = MIN, V _{IL} = MAX, I _{OL} = MAX		0.2	0.4	V	
V _{IK} Input clamp voltage	V _{CC} = MIN, I _I = I _{IK}			-1.5	V	
I _I Input current at maximum input voltage	V _{CC} = MAX, V _I = 5.5V			1.0	mA	
I _{IH} HIGH-level input current	V _{CC} = MAX, V _I = 2.4V	I _O input		40	μA	
		Other inputs		80	μA	
I _{IL} LOW-level input current	V _{CC} = MAX, V _I = 0.4V	I _O input		-1.6	mA	
		Other inputs		-3.2	mA	
I _{OS} Short-circuit output current ³	V _{CC} = MAX	-35		-85	mA	
I _{CC} Supply current ⁴ (total)	V _{CC} = MAX	Condition 1		40	60	mA
		Condition 2		35	55	mA

NOTES:

- For conditions shown as MIN or MAX, use the appropriate value specified under recommended operating conditions for the applicable type.
- All typical values are at V_{CC} = 5V, T_A = 25°C.
- I_{OS} is tested with V_{OUT} = +0.5V and V_{CC} = V_{CC} MAX + 0.5V. Not more than one output should be shorted at a time and duration of the short circuit should not exceed one second.
- Condition 1: Measure I_{CC} with I₇ (from I₀) and E₁ grounded, other inputs and outputs open. Condition 2: Measure I_{CC} with all inputs and outputs open.

AC WAVEFORMS

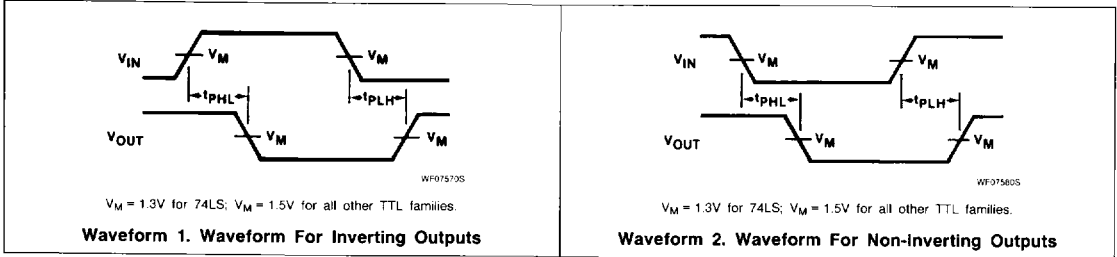

Encoder

74148

AC ELECTRICAL CHARACTERISTICS $T_A = 25^\circ\text{C}$, $V_{CC} = 5.0\text{V}$

PARAMETER	TEST CONDITIONS	74		UNIT	
		$C_L = 15\text{pF}$, $R_L = 400\Omega$			
		Min	Max		
t_{PLH} t_{PHL}	Propagation delay I_n input to \bar{A}_n outputs	Waveform 2, in-phase output		15 14	ns
t_{PLH} t_{PHL}	Propagation delay I_n input to \bar{A}_n outputs	Waveform 1, out-of-phase output		19 19	ns
t_{PLH} t_{PHL}	Propagation delay I_n input to $\bar{E}O$ output	Waveform 1, out-of-phase output		10 25	ns
t_{PLH} t_{PHL}	Propagation delay I_n input to $\bar{G}S$ output	Waveform 2, in-phase output		30 25	ns
t_{PLH} t_{PHL}	Propagation delay $\bar{E}I$ input to \bar{A}_n outputs	Waveform 2, in-phase output		15 15	ns
t_{PLH} t_{PHL}	Propagation delay $\bar{E}I$ input to $\bar{E}O$ output	Waveform 2, in-phase output		15 30	ns
t_{PLH} t_{PHL}	Propagation delay $\bar{E}I$ input to $\bar{G}S$ output	Waveform 2, in-phase output		12 15	ns

TEST CIRCUITS AND WAVEFORMS

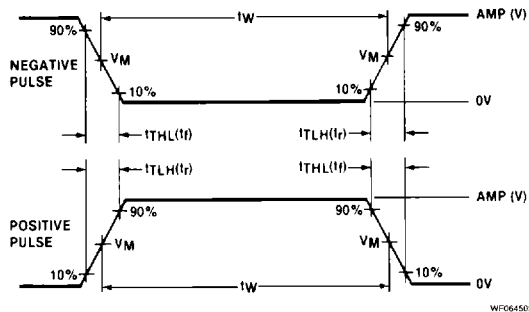
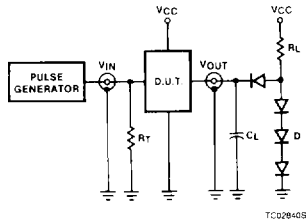

$V_M = 1.3\text{V}$ for 74LS; $V_M = 1.5\text{V}$ for all other TTL families.

Test Circuit For 74 Totem-Pole Outputs

DEFINITIONS

- R_L = Load resistor to V_{CC} ; see AC CHARACTERISTICS for value.
- C_L = Load capacitance includes jig and probe capacitance; see AC CHARACTERISTICS for value.
- R_T = Termination resistance should be equal to Z_{OUT} of Pulse Generators.
- D = Diodes are 1N916, 1N3064, or equivalent.
- t_{TLH} , t_{THL} Values should be less than or equal to the table entries.

Input Pulse Definition

FAMILY	INPUT PULSE REQUIREMENTS				
	Amplitude	Rep. Rate	Pulse Width	t_{TLH}	t_{THL}
74	3.0V	1MHz	500ns	7ns	7ns
74LS	3.0V	1MHz	500ns	15ns	6ns
74S	3.0V	1MHz	500ns	2.5ns	2.5ns

5