

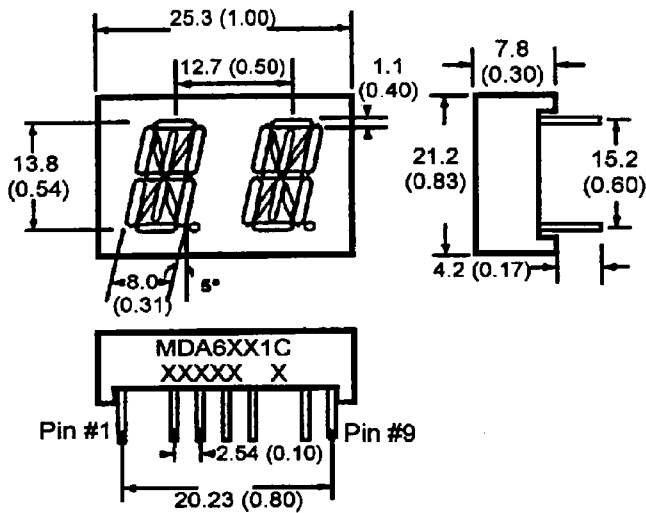

0.54 INCH (13.8MM) 14 SEGMENT, DUAL DIGIT ALPHA - NUMERIC STICK DISPLAY

BRIGHT RED	MDA6141C
YELLOW	MDA6341C
GREEN	MDA6441C
HIGH EFF. RED	MDA6941C

PACKAGE DIMENSIONS



FEATURES

- Easy to read digits.
- 2 digit common cathode.
- Multiplexing pin out
- Low power consumption.
- Bold segments that are highly visible.
- High brightness with high contrast
- White segments on a grey face.
- Directly compatible with integrated circuits.
- Rugged plastic/epoxy construction.

APPLICATIONS

- Digital readout displays.
- Instrument panels.

NOTES: Dimensions are in mm (inch).
All pins are 0.5 (0.02) diameter
Tolerances are ± 0.25 (0.1) unless otherwise noted.

MODEL NUMBERS

<u>Part number</u>	<u>Color</u>	<u>Description</u>
MDA6141C	Bright Red	2 Digit; Common Cathode; Rt.Hand Decimal
MDA6341C	Yellow	2 Digit; Common Cathode; Rt.Hand Decimal
MDA6441C	Green	2 Digit; Common Cathode; Rt Hand Decimal
MDA6941C	High Eff. Red	2 Digit; Common Cathode; Rt Hand Decimal

(For other color options, contact your local area Sales Office)



**0.54 INCH (13.8MM)
14 SEGMENT, DUAL DIGIT
ALPHA - NUMERIC STICK DISPLAY**

ABSOLUTE MAXIMUM RATING ($T_A=25^{\circ}\text{C}$ unless otherwise specified)

Part number	B.Red MDA 6141C	Yellow MDA 6341C	Green MDA 6441C	High Eff. Red MDA 6941C	Unit
Continuous forward current (I_f) Per Segment.....	15	20	30	30	mA
Peak forward current per die (I_f). (at $f = 1.0$ KHz, Duty factor = 1/10)	50	80	90	160	mA
Power dissipation (P_D).....	40*	70*	70*	90*	mW
*Derate Linearly From 25°C	0.17	0.25	0.33	0.33	mW/ $^{\circ}\text{C}$
Reverse voltage per dice.....	5V				
Operating and Storage temperature range.....	- 40°C to $+85^{\circ}\text{C}$				
Lead soldering time (at 1/16 inch from the bottom of lamp).....	5 seconds @ 230°C				

ELECTRO - OPTICAL CHARACTERISTICS ($T_A = 25^{\circ}\text{C}$ unless otherwise specified)

Part number	B. Red MDA <u>6141C</u>	Yellow MDA <u>6341C</u>	Green MDA <u>6441C</u>	High Eff. Red MDA <u>6941C</u>	Test Condition
Luminous intensity (ucd) minimum	500	1000	750	1000	$I_f = 20$ mA
typical	1400	4000	5000	4000	$I_f = 20$ mA
Forward voltage (V_F) typical	2.1	2.1	2.1	2.0	$I_f = 20$ mA
maximum	2.6	2.8	2.8	2.8	$I_f = 20$ mA
Peak wavelength (nm)	697	590	570	635	$I_f = 20$ mA
Spectral line half width (nm)	90	30	30	35	$I_f = 20$ mA
Reverse breakdown voltage (V_R)	5	5	5	5	$I_r = 100$ uA



0.54 INCH (13.8MM)
14 SEGMENT, DUAL DIGIT
ALPHA - NUMERIC STICK DISPLAY

PINOUT

MDA6X41C - Common Cathode

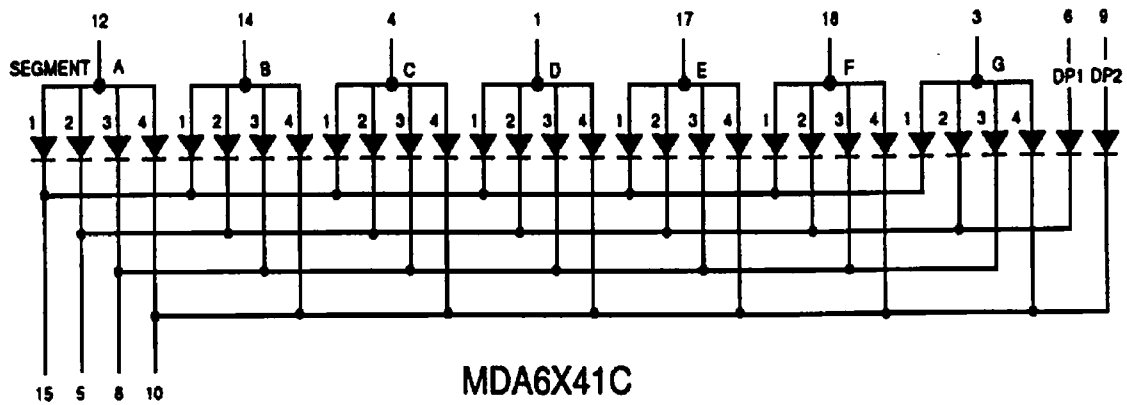
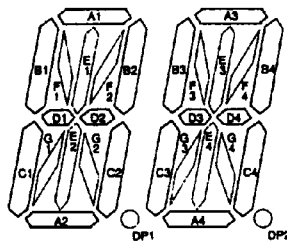



0.54 INCH (13.8MM) 14 SEGMENT, DUAL DIGIT ALPHA - NUMERIC STICK DISPLAY

GRAPHICAL DETAIL: Bright Red

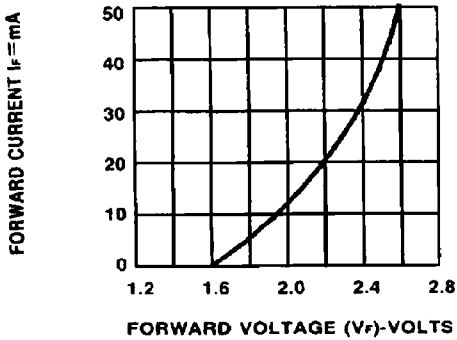

Fig.1 FORWARD CURRENT VS. FORWARD VOLTAGE.

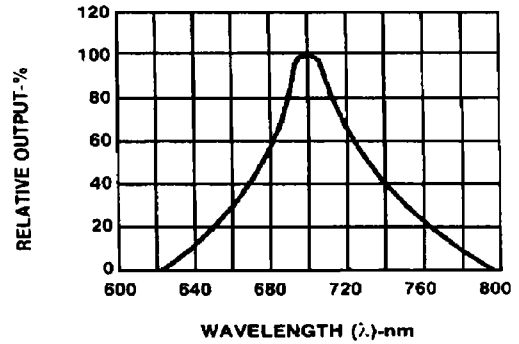

Fig.2 SPECTRAL RESPONSE

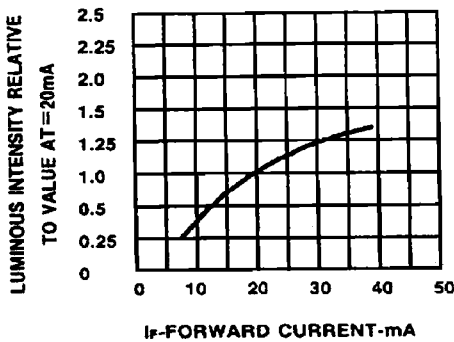

Fig.3 RELATIVE LUMINOUS INTENSITY VS. FORWARD CURRENT

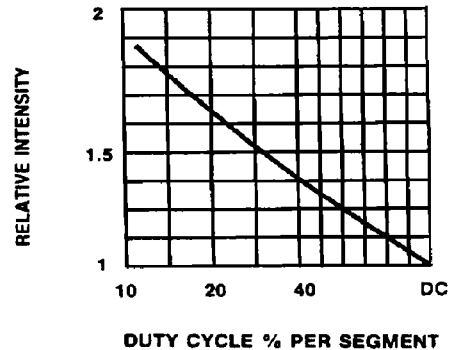

Fig.5 LUMINOUS INTENSITY VS. DUTY CYCLE

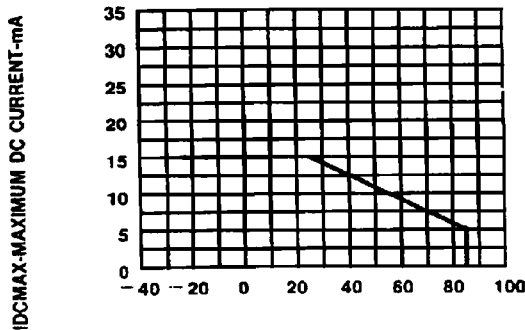

Fig.4 MAXIMUM ALLOWABLE DC CURRENT PER SEGMENT VS. A FUNCTION OF AMBIENT TEMPERATURE.

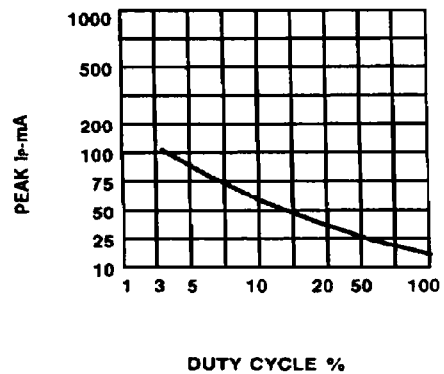

Fig. 6 MAX PEAK CURRENT VS. DUTY CYCLE % (REFRESH RATE f=1 KHz)



0.54 INCH (13.8MM) 14 SEGMENT, DUAL DIGIT ALPHA - NUMERIC STICK DISPLAY

GRAPHICAL DETAIL: Green

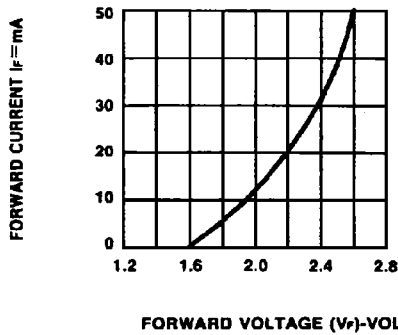

Fig.1 FORWARD CURRENT VS. FORWARD VOLTAGE.

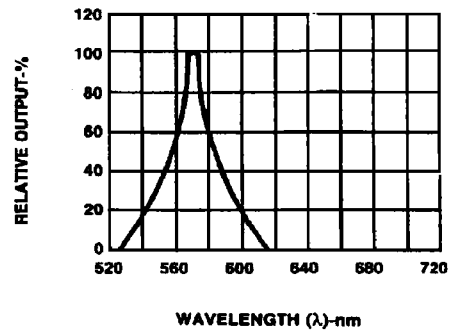

Fig.2 SPECTRAL RESPONSE

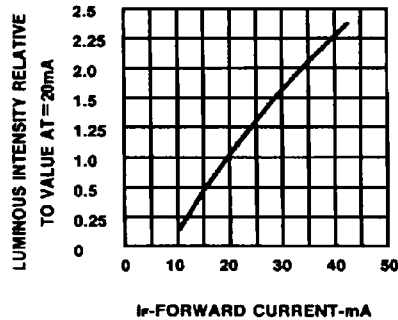

Fig.3 RELATIVE LUMINOUS INTENSITY VS. FORWARD CURRENT

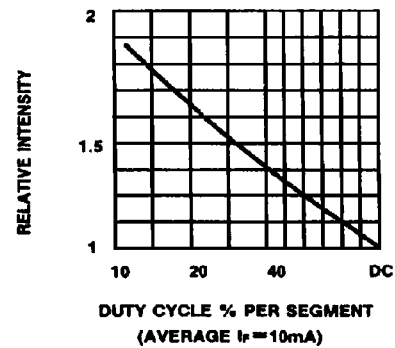

Fig.5 LUMINOUS INTENSITY VS. DUTY CYCLE

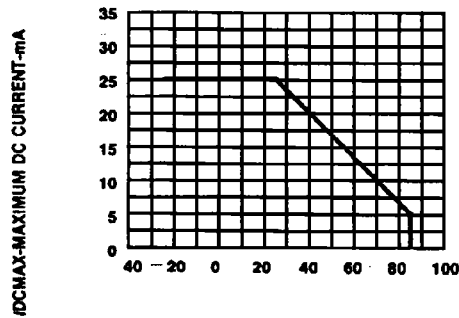

Fig.4 MAXIMUM ALLOWABLE DC CURRENT PER SEGMENT CS. A FUNCTION OF AMBIENT TEMPERATURE.

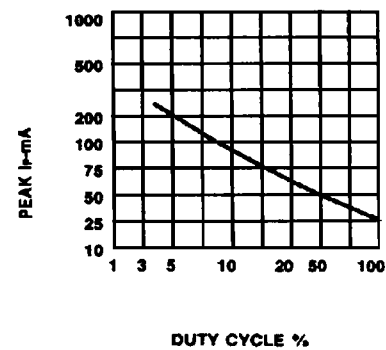

Fig.6 MAX PEAK CURRENT VS. DUTY CYCLE % (REFRESH RATE f = 1 KHz)



0.54 INCH (13.8MM) 14 SEGMENT, DUAL DIGIT ALPHA - NUMERIC STICK DISPLAY

GRAPHICAL DETAIL: High Efficiency Red

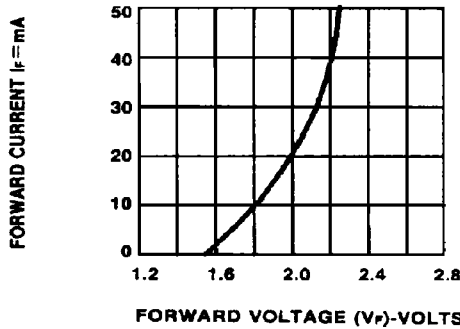

Fig.1 FORWARD CURRENT VS. FORWARD VOLTAGE.

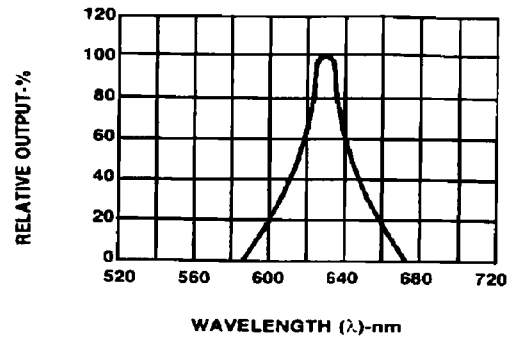

Fig.2 SPECTRAL RESPONSE

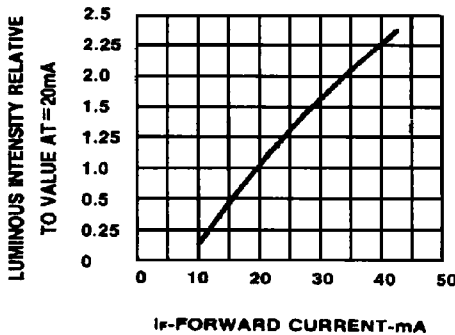

Fig.3 RELATIVE LUMINOUS INTENSITY VS. FORWARD CURRENT

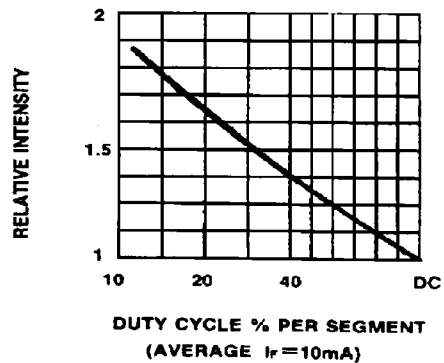

Fig.5 LUMINOUS INTENSITY VS. DUTY CYCLE

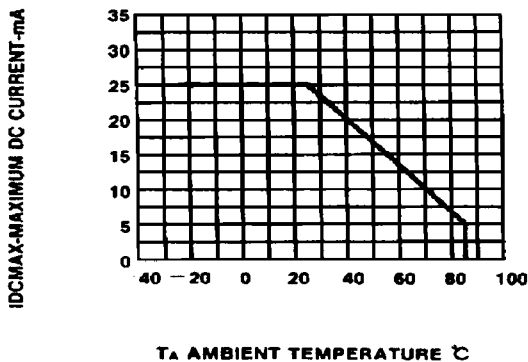

Fig.4 MAXIMUM ALLOWABLE DC CURRENT PER SEGMENT VS. A FUNCTION OF AMBIENT TEMPERATURE.

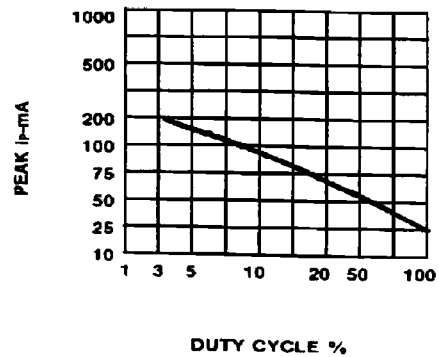

Fig.6 MAX PEAK CURRENT VS. DUTY CYCLE % (REFRESH RATE f = 1 KHz)



0.54 INCH (13.8MM) 14 SEGMENT, DUAL DIGIT ALPHA - NUMERIC STICK DISPLAY

GRAPHICAL DETAIL: Yellow

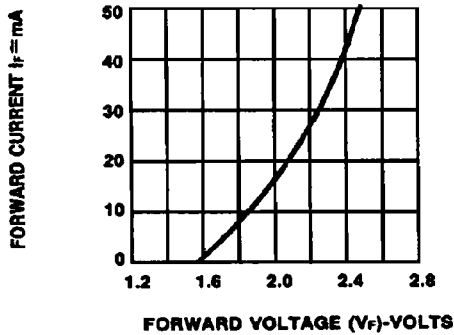

Fig.1 FORWARD CURRENT VS. FORWARD VOLTAGE.

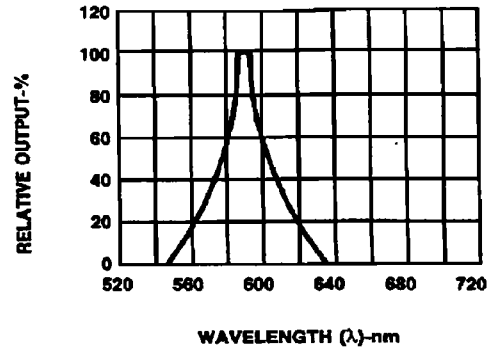

Fig.2 SPECTRAL RESPONSE

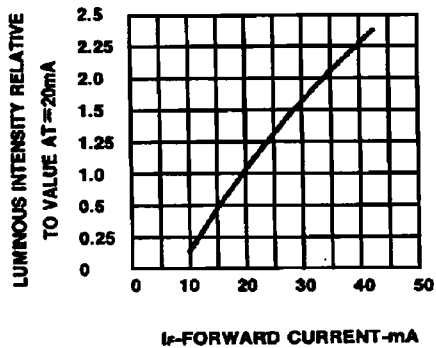

Fig.3 RELATIVE LUMINOUS INTENSITY VS. FORWARD CURRENT

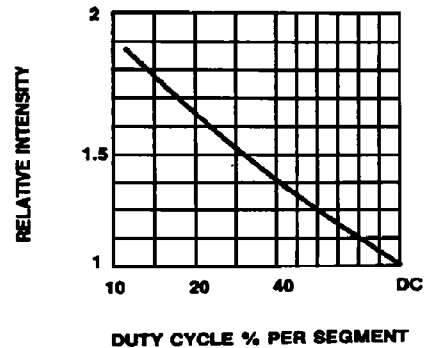

Fig.5 LUMINOUS INTENSITY VS. DUTY CYCLE

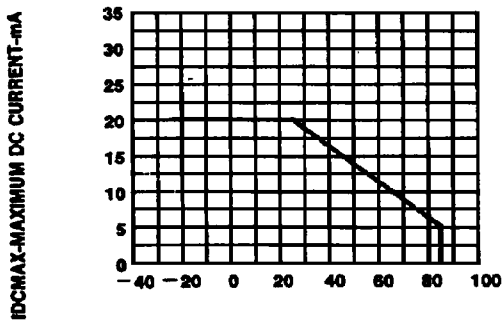

Fig.4 MAXIMUM ALLOWABLE DC CURRENT PER SEGMENT VS. A FUNCTION OF AMBIENT TEMPERATURE.

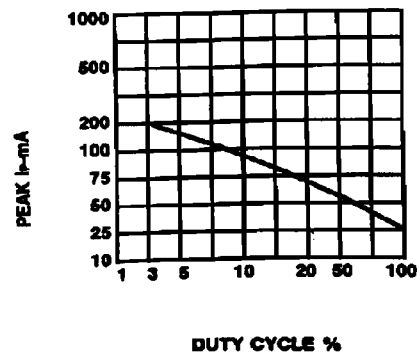

Fig.6 MAX PEAK CURRENT VS. DUTY CYCLE % (REFRESH RATE f = 1 KHz)