

TENTATIVE TOSHIBA MOS DIGITAL INTEGRATED CIRCUIT SILICON MONOLITHIC
 4,194,304-WORDS×4BANKS×16-BITS DOUBLE DATA RATE FAST CYCLE RAM
 8,388,608-WORDS×4BANKS×8-BITS DOUBLE DATA RATE FAST CYCLE RAM

DESCRIPTION

TC59LM814/06BFT are a CMOS Double Data Rate Fast Cycle Random Access Memory (DDR FCRAM) containing 268,435,456 memory cells. TC59LM814BFT is organized as 4,194,304-words×4 banks×16 bits, TC59LM806BFT is organized as 8,388,608 words×4 banks×8 bits. TC59LM814/06BFT feature a fully synchronous operation referenced to clock edge whereby all operations are synchronized at a clock input which enables high performance and simple user interface coexistence. TC59LM814/06BFT can operate fast core cycle using the FCRAM core architecture compared with regular DDR SDRAM. TC59LM814/06BFT is suitable for Servers, Network and other applications where large memory density and low power consumption are required. The Output Driver for FCRAM is capable of high quality fast data transfer under light loading conditions.

FEATURES

ITEM		TC59LM814/06			
		- 22	- 24	- 30	
t _{CK}	Clock Cycle Time (Min.)	CL = 2	7.5 ns	8 ns	10 ns
		CL = 3	6.5 ns	7 ns	7.5 ns
t _{RC}	Random Read/Write Cycle Time (Min.)	30 ns	32 ns	40 ns	
t _{RAC}	Random Access Time (Max.)	22.5 ns	24 ns	30 ns	
I _{DD1S}	Operating Current (Single bank) (Max.)	170 mA	165 mA	150 mA	
I _{DD2P}	Power Down Current (Max.)	2 mA	2 mA	2 mA	
I _{DD6}	Self - Refresh Current (Max.)	3 mA	3 mA	3 mA	

- Fully Synchronous Operation
 - Double Data Rate (DDR)
 - Data input/output are synchronized with both edges of DQS.
 - Differential Clock (CLK and $\overline{\text{CLK}}$) inputs
 - $\overline{\text{CS}}$, FN and all address input signals are sampled on the positive edge of CLK.
 - Output data (DQs and $\overline{\text{DQS}}$) is referenced to the crossings of CLK and $\overline{\text{CLK}}$.
- Fast clock cycle time of 6.5ns minimum
 - Clock : 154MHz maximum
 - Data : 308Mbps / pin maximum
- Quad Independent Banks operation
- Bidirectional Data Strobe Signal
- Self-Refresh
- Variable Write Length Control
- Programmable $\overline{\text{CAS}}$ Latency and Burst Length
 - $\overline{\text{CAS}}$ Latency = 2, 3
 - Burst Length = 2, 4
- Organization
 - TC59LM814BFT : 4,194,304 words × 4 banks × 16 bits
 - TC59LM806BFT : 8,388,608 words × 4 banks × 8 bits
- Power supply voltage
 - V_{dd} : 2.5V ± 0.2V
 - V_{ddQ} : 2.5V ± 0.2V

Notice : FCRAM is a trademark of Fujitsu Limited, Japan.

000707EBA2

- TOSHIBA is continually working to improve the quality and reliability of its products. Nevertheless, semiconductor devices in general can malfunction or fail due to their inherent electrical sensitivity and vulnerability to physical stress. It is the responsibility of the buyer, when utilizing TOSHIBA products, to comply with the standards of safety in making a safe design for the entire system, and to avoid situations in which a malfunction or failure of such TOSHIBA products could cause loss of human life, bodily injury or damage to property. In developing your designs, please ensure that TOSHIBA products are used within specified operating ranges as set forth in the most recent TOSHIBA products specifications. Also, please keep in mind the precautions and conditions set forth in the "Handling Guide for Semiconductor Devices," or "TOSHIBA Semiconductor Reliability Handbook" etc..
- The TOSHIBA products listed in this document are intended for usage in general electronics applications (computer, personal equipment, office equipment, measuring equipment, industrial robotics, domestic appliances, etc.). These TOSHIBA products are neither intended nor warranted for usage in equipment that requires extraordinarily high quality and/or reliability or a malfunction or failure of which may cause loss of human life or bodily injury ("Unintended Usage"). Unintended Usage include atomic energy control instruments, airplane or spaceship instruments, transportation instruments, traffic signal instruments, combustion control instruments, medical instruments, all types of safety devices, etc.. Unintended Usage of TOSHIBA products listed in this document shall be made at the customer's own risk.
- The products described in this document are subject to the foreign exchange and foreign trade laws.
- The information contained herein is presented only as a guide for the applications of our products. No responsibility is assumed by TOSHIBA CORPORATION for any infringements of intellectual property or other rights of the third parties which may result from its use. No license is granted by implication or otherwise under any intellectual property or other rights of TOSHIBA CORPORATION or others.
- The information contained herein is subject to change without notice.

PIN NAMES

Pin	Name
A0 to A14	Address Input
BA0, BA1	Bank Address
DQ0 to DQ7 (×8)	Data Input/Output
DQ0 to DQ15 (×16)	
\overline{CS}	Chip Select
FN	Function Control
\overline{PD}	Power Down Control
CLK, (\overline{CLK})	Clock input
DQS (×8)	Write/Read Data Strobe
UDQS/LDQS (×16)	
Vdd	Power (+ 2.5V)
V _{SS}	Ground
VddQ	Power (+ 2.5V) (for I/O buffer)
V _{SSQ}	Ground (for I/O buffer)
V _{REF}	Reference voltage
NC1, NC2	No Connection

PIN ASSIGNMENT (TOP VIEW)

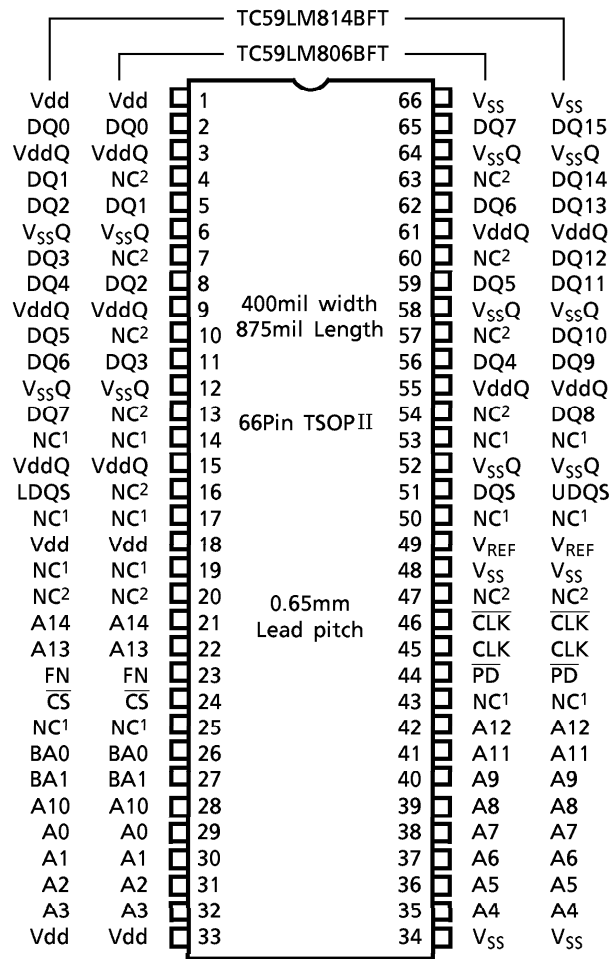

BLOCK DIAGRAM

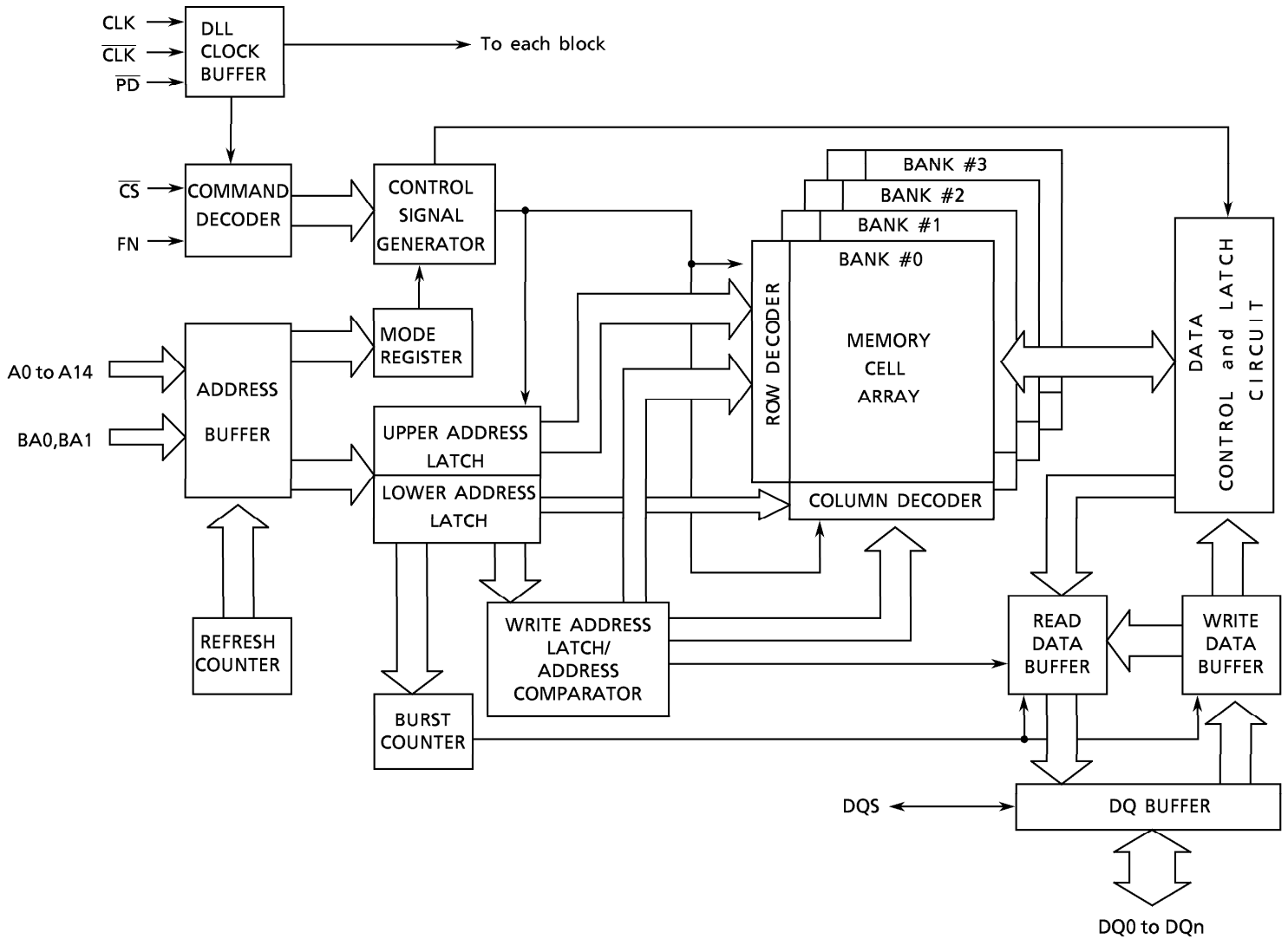

NOTE : The TC59LM806BFT configuration is 32768×256×8 of cell array with the DQ pins numbered DQ0-7.
 The TC59LM814BFT configuration is 32768×128×16 of cell array with the DQ pins numbered DQ0-15.

ABSOLUTE MAXIMUM RATINGS

SYMBOL	PARAMETER	RATING	UNITS	NOTES
V _{IN} , V _{OUT}	Input , Output Voltage	- 0.3 to V _{ddQ} + 0.3	V	
V _{dd} , V _{ddQ}	Power Supply Voltage	- 0.3 to 3.6	V	
V _{REF}	Input Reference Voltage	- 0.3 to 3.6	V	
T _{OPR}	Operating Temperature	0 to 70	°C	
T _{STG}	Storage Temperature	- 55 to 150	°C	
T _{SOLDER}	Soldering Temperature(10s)	260	°C	
P _D	Power Dissipation	1	W	
I _{OUT}	Short Circuit Output Current	± 50	mA	

Caution: Conditions outside the limits listed under "ABSOLUTE MAXIMUM RATINGS" may cause permanent damage to the device. The device is not meant to be operated under conditions outside the limits described in the operational section of this specification. Exposure to "ABSOLUTE MAXIMUM RATINGS" conditions for extended periods may affect device reliability.

RECOMMENDED DC, AC OPERATING CONDITIONS (Notes: 1) (Ta = 0 to 70°C)

SYMBOL	PARAMETER	MIN	TYP	MAX	UNIT	NOTES
V _{dd}	Power Supply Voltage	2.3	2.5	2.7	V	
V _{ddQ}	Power Supply Voltage (for I/O Buffer)	2.3	V _{dd}	V _{dd}	V	
V _{REF}	Input Reference Voltage	V _{ddQ} /2*96%	V _{ddQ} /2	V _{ddQ} /2*104%	V	2
V _{IH} (DC)	Input DC High Voltage	V _{REF} + 0.2	-	V _{ddQ} + 0.2	V	5
V _{IL} (DC)	Input DC Low Voltage	- 0.1	-	V _{REF} - 0.2	V	5
V _{ICK} (DC)	Differential Clock DC Input Voltage	- 0.1	-	V _{ddQ} + 0.1	V	10
V _{ID} (DC)	Input Differential Voltage. CLK and $\overline{\text{CLK}}$ inputs (DC)	0.4	-	V _{ddQ} + 0.2	V	7,10
V _{IH} (AC)	Input AC High Voltage	V _{REF} + 0.35	-	V _{ddQ} + 0.2	V	3, 6
V _{IL} (AC)	Input AC Low Voltage	- 0.1	-	V _{REF} - 0.35	V	4, 6
V _{ID} (AC)	Input Differential Voltage. CLK and $\overline{\text{CLK}}$ inputs (AC)	0.7	-	V _{ddQ} + 0.2	V	7,10
V _X (AC)	Differential AC Input Cross Point Voltage	V _{ddQ} /2 - 0.2	-	V _{ddQ} /2 + 0.2	V	8,10
V _{ISO} (AC)	Differential Clock AC Middle Level	V _{ddQ} /2 - 0.2	-	V _{ddQ} /2 + 0.2	V	9,10

- Notes:
1. All voltages are referenced to V_{SS} , V_{SSQ} .
 2. V_{REF} is expected to track variations in V_{ddQ} DC level of the transmitting device. Peak to peak AC noise on V_{REF} may not exceed $\pm 2\%$ of $V_{REF}(DC)$.
 3. Overshoot limit : $V_{IH}(max.) = V_{ddQ} + 0.9V$ with a pulse width $\leq 5ns$
 4. Undershoot limit : $V_{IL}(min.) = -0.9V$ with a pulse width $\leq 5ns$
 5. $V_{IH}(DC)$ and $V_{IL}(DC)$ are levels to maintain the current logic state.
 6. $V_{IH}(AC)$ and $V_{IL}(AC)$ are levels to change to the new logic state.
 7. V_{ID} is magnitude of the difference between CLK input level and \overline{CLK} input level.
 8. The value of $V_X(AC)$ is expected to equal $V_{ddQ}/2$ of the transmitting device.
 9. V_{ISO} means $\{ V_{ICK}(CLK) + V_{ICK}(\overline{CLK}) \} / 2$.
 10. Refer to the figure below.

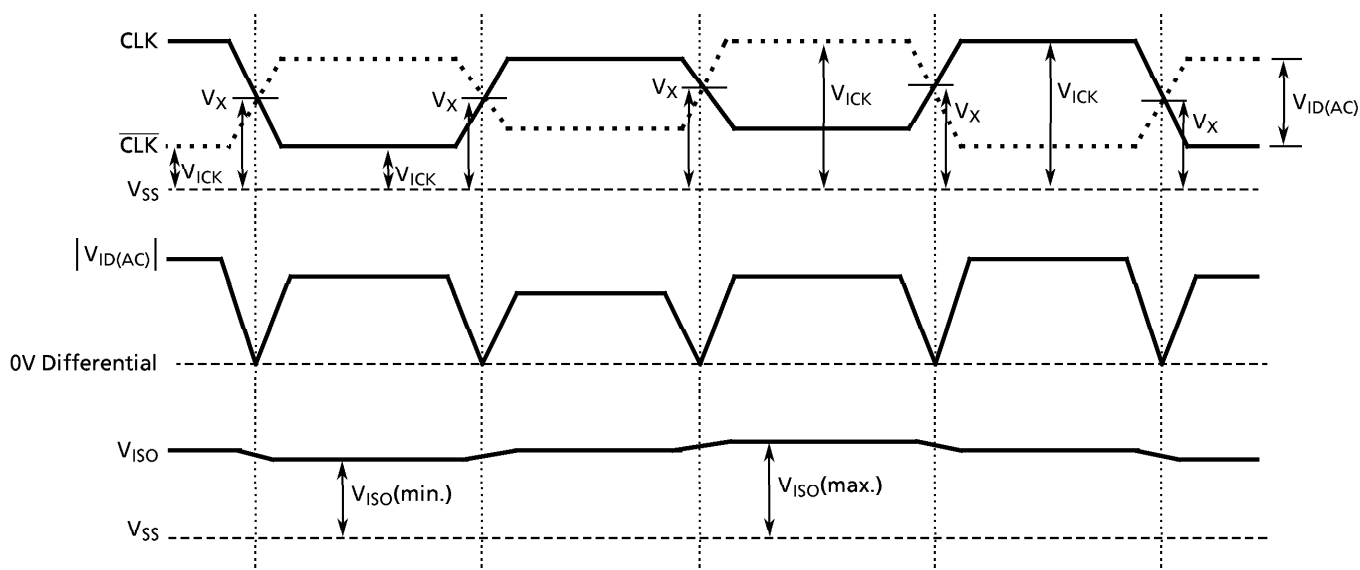

11. In the case of external termination, V_{TT} (Termination Voltage) should be gone in the range of $V_{REF}(DC) \pm 0.04V$.

PIN CAPACITANCE ($V_{dd}, V_{ddQ} = 2.5V$, $f = 1MHz$, $T_a = 25^\circ C$)

SYMBOL	PARAMETER	MIN	MAX	UNIT
C_{IN}	Input Pin Capacitance	2.5	4.0	pF
C_{INC}	Clock Pin (CLK, \overline{CLK}) Capacitance	2.5	4.0	pF
$C_{I/O}$	I/O Pin (DQ, DQS) Capacitance	4.0	6.0	pF
C_{NC^1}	NC ¹ Pin Capacitance	-	1.5	pF
C_{NC^2}	NC ² Pin Capacitance	4.0	6.0	pF

Note : These parameters are periodically sampled and not 100% tested.
 The NC² pins have additional capacitance for adjustment of the adjacent pin capacitance.
 The NC² pins have Power and Ground clamp.

RECOMMENDED DC OPERATING CONDITIONS ($V_{DD}, V_{DDQ} = 2.5V \pm 0.2V, T_a = 0 \sim 70^\circ C$)

ITEM	SYMBOL	MAX.			UNIT	NOTES
		- 22	- 24	- 30		
OPERATING CURRENT $t_{CK} = \min, I_{RC} = \min$ Read/Write command cycling $0V \leq V_{IN} \leq V_{IL(AC)}(\max.), V_{IH(AC)}(\min.) \leq V_{IN} \leq V_{DDQ}$ 1 bank operation, Burst Length = 4 Address change up to 2 times during minimum I_{RC} .	I_{DD1S}	170	165	150	mA	1, 2
STANDBY CURRENT $t_{CK} = \min, \overline{CS} = V_{IH}, \overline{PD} = V_{IH},$ $0V \leq V_{IN} \leq V_{IL(AC)}(\max.), V_{IH(AC)}(\min.) \leq V_{IN} \leq V_{DDQ}$ All Banks: inactive state Other input signals are changed one time during $4 \cdot t_{CK}$.	I_{DD2N}	45	40	35		1
STANDBY (POWER DOWN) CURRENT $t_{CK} = \min, \overline{CS} = V_{IH}, \overline{PD} = V_{IL}(\text{Power Down})$ $0V \leq V_{IN} \leq V_{DDQ}$ All Banks: inactive state	I_{DD2P}	2	2	2		1
AUTO-REFRESH CURRENT $t_{CK} = \min, I_{REFC} = \min, t_{REFI} = \min$ Auto-Refresh command cycling $0V \leq V_{IN} \leq V_{IL(AC)}(\max.), V_{IH(AC)}(\min.) \leq V_{IN} \leq V_{DDQ}$ Address change up to 2 times during minimum I_{REFC} .	I_{DD5}	65	60	55		1
SELF-REFRESH CURRENT Self-Refresh mode $\overline{PD} = 0.2V, 0V \leq V_{IN} \leq V_{DDQ}$	I_{DD6}	3	3	3		

ITEM		SYMBOL	MIN.	MAX.	UNITS	NOTES
INPUT LEAKAGE CURRENT ($0V \leq V_{IN} \leq V_{DDQ},$ All other pins not under test = $0V$)		I_{LI}	-5	5	μA	
OUTPUT LEAKAGE CURRENT (Output disabled, $0V \leq V_{OUT} \leq V_{DDQ}$)		I_{LO}	-5	5	μA	
V_{REF} CURRENT		I_{REF}	-5	5	μA	
Output Driver	OUTPUT SOURCE DC CURRENT $V_{OH} = V_{DDQ} - 0.4V$	$I_{OH}(DC)$	-10	-	mA	3
	OUTPUT SINK DC CURRENT $V_{OL} = 0.4V$	$I_{OL}(DC)$	10	-	mA	3

- Notes:
1. These parameters depend on the cycle rate and these values are measured at a cycle rate with the minimum values of t_{CK}, t_{RC} and I_{RC} .
 2. These parameters depend on the output loading. The specified values are obtained with the output open.
 3. Refer to output driver characteristics for the detail.

AC CHARACTERISTICS AND OPERATING CONDITIONS (Notes : 1, 2)

SYM BOL	PARAMETER	- 22		- 24		- 30		UNITS	NOTES	
		MIN.	MAX.	MIN.	MAX.	MIN.	MAX.			
t _{RC}	Random Cycle Time	30	-	32	-	40	-	ns	3	
t _{CK}	Clock Cycle Time	CL = 2	7.5	10	8	10	10		10.5	3
		CL = 3	6.5	10	7	10	7.5		10	3
t _{RAC}	Random Access Time	-	22.5	-	24	-	30		3	
t _{CH}	Clock High Time	0.45*t _{CK}	-	0.45*t _{CK}	-	0.45*t _{CK}	-		3	
t _{CL}	Clock Low Time	0.45*t _{CK}	-	0.45*t _{CK}	-	0.45*t _{CK}	-		3	
t _{CKQS}	DQS Access Time from CLK	-0.85	0.85	-0.9	0.9	-1	1		3,9	
t _{QSQ}	Data Output Skew from DQS	-0.52	0.52	-0.56	0.56	-0.64	0.64		4	
t _{AC}	Data Access Time from CLK	-0.85	0.85	-0.9	0.9	-1	1		3,9	
t _{OH}	Data Output Hold Time from CLK	-0.85	0.85	-0.9	0.9	-1	1		3,9	
t _{QSPRE}	DQS(Read) Preamble Pulse Width	0.9*t _{CK} -0.2	1.1*t _{CK} +0.2	0.9*t _{CK} -0.2	1.1*t _{CK} +0.2	0.9*t _{CK} -0.2	1.1*t _{CK} +0.2		3	
t _{QSP}	DQS(Read) Pulse Width	0.4*t _{CK} -0.2	-	0.4*t _{CK} -0.2	-	0.4*t _{CK} -0.2	-		4	
t _{QSQV}	Data Output Valid Time from DQS	0.4*t _{CK} -0.4	-	0.4*t _{CK} -0.4	-	0.4*t _{CK} -0.4	-		4	
t _{DQSS}	DQS(Write) Low to High Setup Time	0.75*t _{CK}	1.25*t _{CK}	0.75*t _{CK}	1.25*t _{CK}	0.75*t _{CK}	1.25*t _{CK}		3	
t _{DSPRE}	DQS(Write) Preamble Pulse Width	0.4*t _{CK}	-	0.4*t _{CK}	-	0.4*t _{CK}	-		4	
t _{DSPRES}	DQS First Input Setup Time	0	-	0	-	0	-		3	
t _{DSPREH}	DQS First Low Input Hold Time	0.25*t _{CK}	-	0.25*t _{CK}	-	0.25*t _{CK}	-		3	
t _{DSP}	DQS High or Low Input Pulse Width	0.45*t _{CK}	0.55*t _{CK}	0.45*t _{CK}	0.55*t _{CK}	0.45*t _{CK}	0.55*t _{CK}		4	
t _{DSS}	DQS Input Falling Edge to Clock Setup Time	CL = 2	1.5	-	1.6	-	2		-	3,4
		CL = 3	1.5	-	1.5	-	1.6		-	3,4
t _{DSPST}	DQS (Write) Postamble Pulse Width	0.45*t _{CK}	-	0.45*t _{CK}	-	0.45*t _{CK}	-		4	
t _{DSPSTH}	DQS (Write) Postamble Hold Time	CL = 2	1.5	-	1.6	-	2		-	3,4
		CL = 3	1.5	-	1.5	-	1.6		-	3,4
t _{DSSK}	UDQS - LDQS Skew (x16)	-0.25*t _{CK}	0.25*t _{CK}	-0.25*t _{CK}	0.25*t _{CK}	-0.25*t _{CK}	0.25*t _{CK}			
t _{DS}	Data Input Setup Time from DQS	0.6	-	0.6	-	0.8	-		4	
t _{DH}	Data Input Hold Time from DQS	0.6	-	0.6	-	0.8	-		4	
t _{DIPW}	Data Input Pulse Width (for each device)	1.9	-	1.9	-	2.3	-			
t _{IS}	Command / Address Input Setup Time	1	-	1.2	-	1.6	-		3	
t _{IH}	Command / Address Input Hold Time	1	-	1.2	-	1.6	-		3	
t _{IPW}	Command / Address Input Pulse Width (for each device)	2.2	-	2.6	-	3.4	-			
t _{LZ}	Data-out Low Impedance Time from CLK	-0.85	-	-0.9	-	-1	-		3,6,9	
t _{HZ}	Data-out High Impedance Time from CLK	-	0.85	-	0.9	-	1		3,7,9	
t _{QSLZ}	DQS-out Low Impedance Time from CLK	-0.85	-	-0.9	-	-1	-		3,6,9	
t _{QSHZ}	DQS-out High Impedance Time from CLK	-0.85	0.85	-0.9	0.9	-1	1	3,7,9		
t _{QPDH}	Last Output to PD High Hold Time	0	-	0	-	0	-			
t _{PDEX}	Power Down Exit Time	2	-	2	-	3	-	3		
t _T	Input Transition Time	0.2	1	0.2	1	0.2	1			
t _{FPDL}	PD Low Input Window for Self-Refresh Entry	-0.5*t _{CK}	10	-0.5*t _{CK}	10	-0.5*t _{CK}	10	3		
t _{REFI}	Auto-Refresh Average Interval	0.4	7.8	0.4	7.8	0.4	7.8	μs	5	
t _{PAUSE}	Pause Time after Power-up	200	-	200	-	200	-			

AC CHARACTERISTICS AND OPERATING CONDITIONS (Notes : 1, 2) (Continued)

SYM BOL	PARAMETER		- 22		- 24		- 30		UNITS	NOTES
			MIN.	MAX.	MIN.	MAX.	MIN.	MAX.		
I _{RC}	Random Read/Write Cycle Time (Applicable to Same Bank)	CL = 2	4	-	4	-	4	-	cycle	
		CL = 3	5	-	5	-	5	-		
I _{RCD}	RDA/WRA to LAL Command Input Delay (Applicable to Same Bank)		1	1	1	1	1	1		
I _{RAS}	LAL to RDA/WRA Command Input Delay (Applicable to Same Bank)	CL = 2	3	-	3	-	3	-		
		CL = 3	4	-	4	-	4	-		
I _{RBD}	Random Bank Access Delay (Applicable to Other Bank)		2	-	2	-	2	-		
I _{RWD}	LAL following RDA to WRA Delay (Applicable to Other Bank)	BL = 2	2	-	2	-	2	-		
		BL = 4	3	-	3	-	3	-		
I _{WRD}	LAL following WRA to RDA Delay (Applicable to Other Bank)		1	-	1	-	1	-		
I _{RSC}	Mode Register Set Cycle Time	CL = 2	4	-	4	-	4	-		8
		CL = 3	5	-	5	-	5	-	8	
I _{PD}	PD Low to Inactive State of Input Buffer		-	1	-	1	-	1		
I _{PDA}	$\overline{\text{PD}}$ High to Active State of Input Buffer		-	1	-	1	-	1		
I _{REFC}	Auto-Refresh Cycle Time	CL = 2	12	-	12	-	12	-		
		CL = 3	15	-	15	-	15	-		
I _{CKD}	REF Command to Clock Input Disable at Self-Refresh entry		16	-	16	-	16	-		
I _{LOCK}	DLL Lock-on Time (Applicable to RDA command)	t _{CK} ≤ 8ns	200	-	200	-	200	-		
		t _{CK} ≤ 10.5ns	300	-	300	-	300	-		

AC TEST CONDITIONS

SYMBOL	PARAMETER	VALUE	UNITS	NOTES
$V_{IH(min)}$	Input high voltage (minimum)	$V_{REF} + 0.35$	V	
$V_{IL(max)}$	Input low voltage (maximum)	$V_{REF} - 0.35$	V	
V_{REF}	Input reference voltage	$V_{ddQ}/2$	V	
V_{TT}	Termination voltage	V_{REF}	V	
V_{SWING}	Input signal peak to peak swing	1.0	V	
V_r	Differential clock input reference level	$V_X(AC)$	V	
$V_{ID(AC)}$	Input differential voltage	1.5	V	
SLEW	Input signal minimum slew rate	1.0	V/ns	
V_{OTR}	Output timing measurement reference voltage	$V_{ddQ}/2$	V	

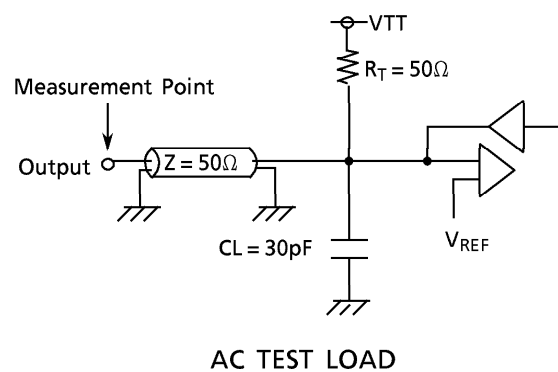
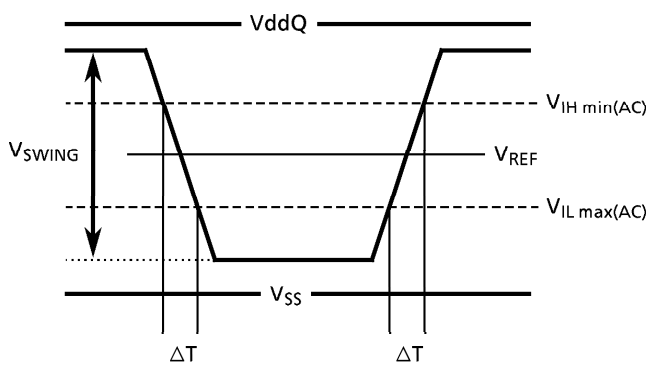

$$SLEW = (V_{IHmin(AC)} - V_{ILmax(AC)}) / \Delta T$$

- Notes:
1. Transition times are measured between $V_{IHmin(DC)}$ and $V_{ILmax(DC)}$. Transition (rise and fall) of input signals have a fixed slope.
 2. If the result of nominal calculation with regard to t_{CK} contains more than one decimal place, the result is rounded up to the nearest decimal place. (i.e., $t_{DQSS} = 0.75 * t_{CK}$, $t_{CK} = 6.5ns$, $0.75 * 6.5ns = 4.875ns$ is rounded up to 4.9ns.)
 3. These parameters are measured from the differential clock (CLK and \overline{CLK}) AC cross point.
 4. These parameters are measured from signal transition point of DQS crossing V_{REF} level.
 5. The $t_{REFI(MAX.)}$ applies to equally distributed refresh method. The $t_{REFI(MIN.)}$ applies to both burst refresh method and distributed refresh method. In such case, the average interval of eight consecutive Auto-Refresh commands has to be more than 400ns always. In other words, the number of Auto-Refresh cycles which can be performed within $3.2\mu s$ ($8 \times 400ns$) is to 8 times in the maximum.
 6. Low Impedance State is specified at $V_{ddQ}/2 \pm 0.2V$ from steady state.
 7. High Impedance State is specified where output buffer is no longer driven.
 8. When Power-up Sequence is performed, the I_{RSC} should be set 5 clock cycles.
 9. These parameters depend on the clock jitter. These parameters are measured at stable clock.

POWER UP SEQUENCE

1. As for \overline{PD} , being maintained by the low state ($\leq 0.2V$) is desirable before a power-supply injection.
2. Apply V_{dd} before or at the same time as V_{ddQ} .
3. Apply V_{ddQ} before or at the same time as V_{REF} .
4. Start clock (CLK, \overline{CLK}) and maintain stable condition for 200 μ s (min.).
5. After stable power and clock, apply DESL and take $\overline{PD} = H$.
6. $\overline{CS} = H$ with either or both BA=L, and along with either A8=L or A7=H.
7. $\overline{CS} = L$ with BA (1-0)=A (14-8)=H, A7=L for two clock cycles (MRS command with Reset Address).
8. $\overline{CS} = H$ and maintain same address input for 4 clock cycles.
9. $\overline{CS} = H$ and change one or more address input within BA (1-0), A (14-7) and maintain them for 4 clock cycles.
10. Issue EMRS to enable DLL. (Note: 1)
11. Issue MRS for set \overline{CAS} Latency (CL), Burst Type (BT), and Burst Length (BL). (Note: 1)
12. Issue two or more Auto-Refresh commands (Note: 1).
13. After 200 (or 300) clocks from Extended Mode Register programming, issue Dummy Write to Bank "0" (WRA#0 and LAL). (Note: 4)
14. Issue Dummy Write to Bank "1" (WRA#1 and LAL). (Note: 4)
15. Issue Dummy Write to Bank "2" (WRA#2 and LAL). (Note: 4)
16. Issue Dummy Write to Bank "3" (WRA#3 and LAL). (Note: 4)
17. Ready for normal operation.

- Note:
1. Sequence 10,11 and 12 can be issued in random order.
 2. The reset/initialization after Power-up can be also performed if the procedure from step 6 to step 13 are issued. Refer to Reset Condition below.
 3. L = Logic Low, H = Logic High
 4. The order of Bank 0, 1, 2 and 3 for Dummy Write Cycles can be changed.

RESET CONDITION

Clock	Command	\overline{CS}	FN	BA1	BA0	A14-9	A8	A7	A6-0
n-13 : 1	DESL	H	X	X or L	L or X	X	L or X	X or H	X
n	RDA	L	H	X	X	X	X	X	X
n + 1	MRS	L	X	H	H	H	H	L	X
n + 2 : 5	DESL	H	X	H	H	H	H	L	X
n + 6	DESL	H	X	Note: 1					X
n + 7 : 10	DESL	H	X	Note: 2					X

- Note:
1. At least one address bit must be flipped from previous state.
 2. Same address input conditions at n + 6 state must be maintained.
 3. L = Logic Low, H = Logic High

TIMING DIAGRAMS

Input Timing

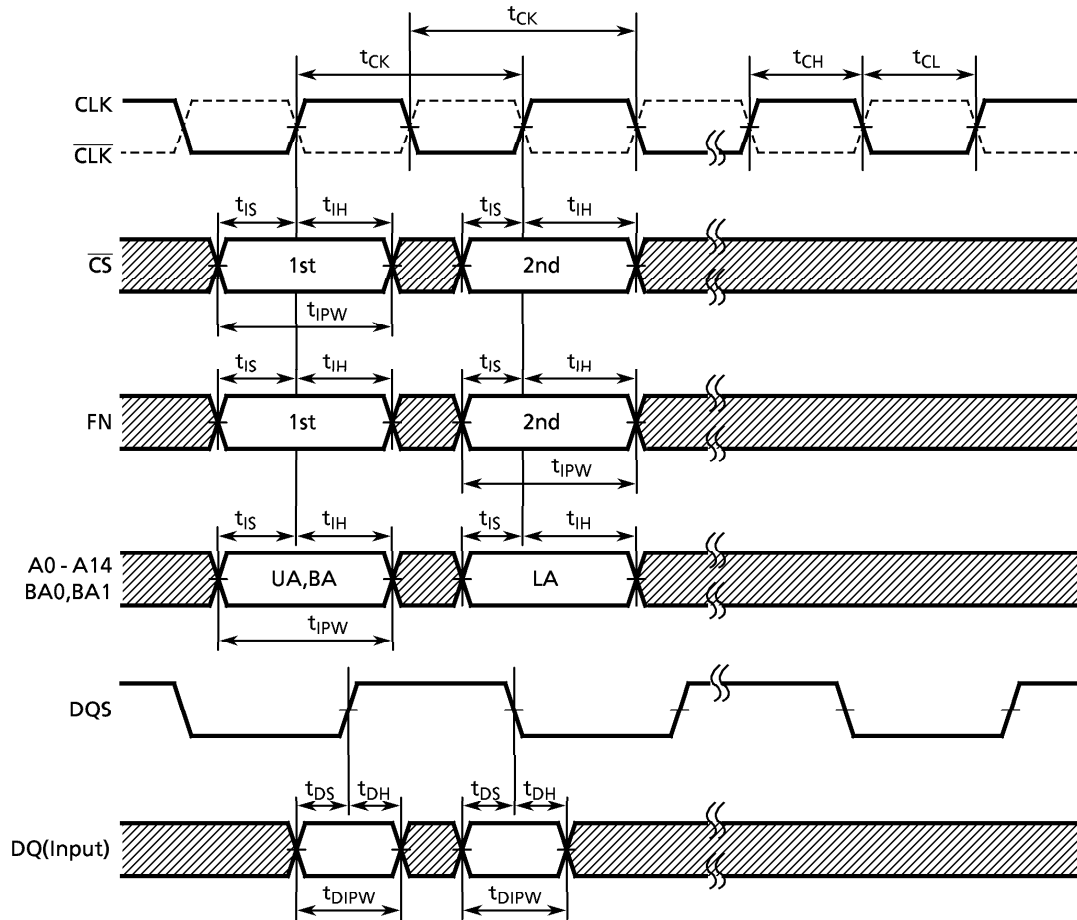

Refer to the Command Truth Table.

Timing of the CLK, /CLK

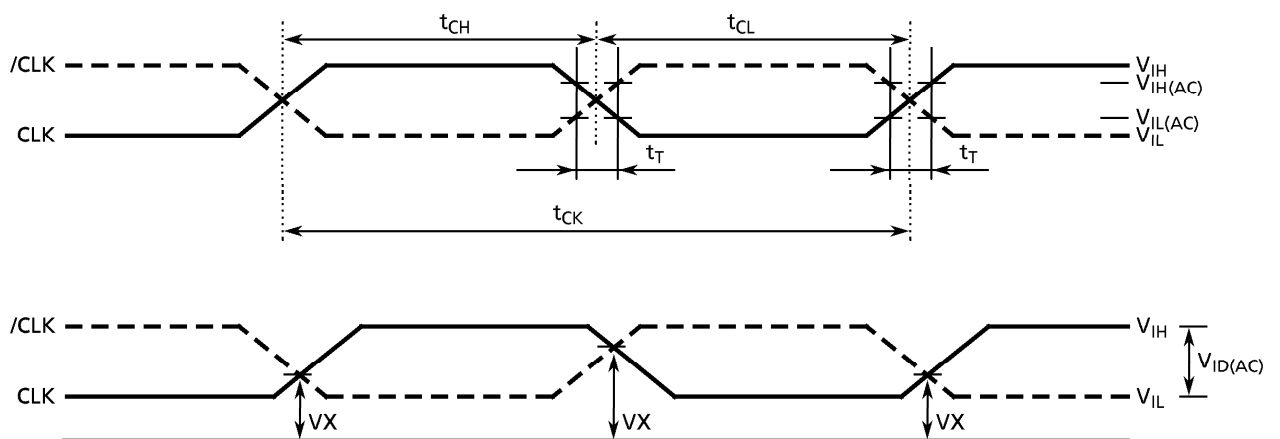

Read Timing (Burst Length = 4)

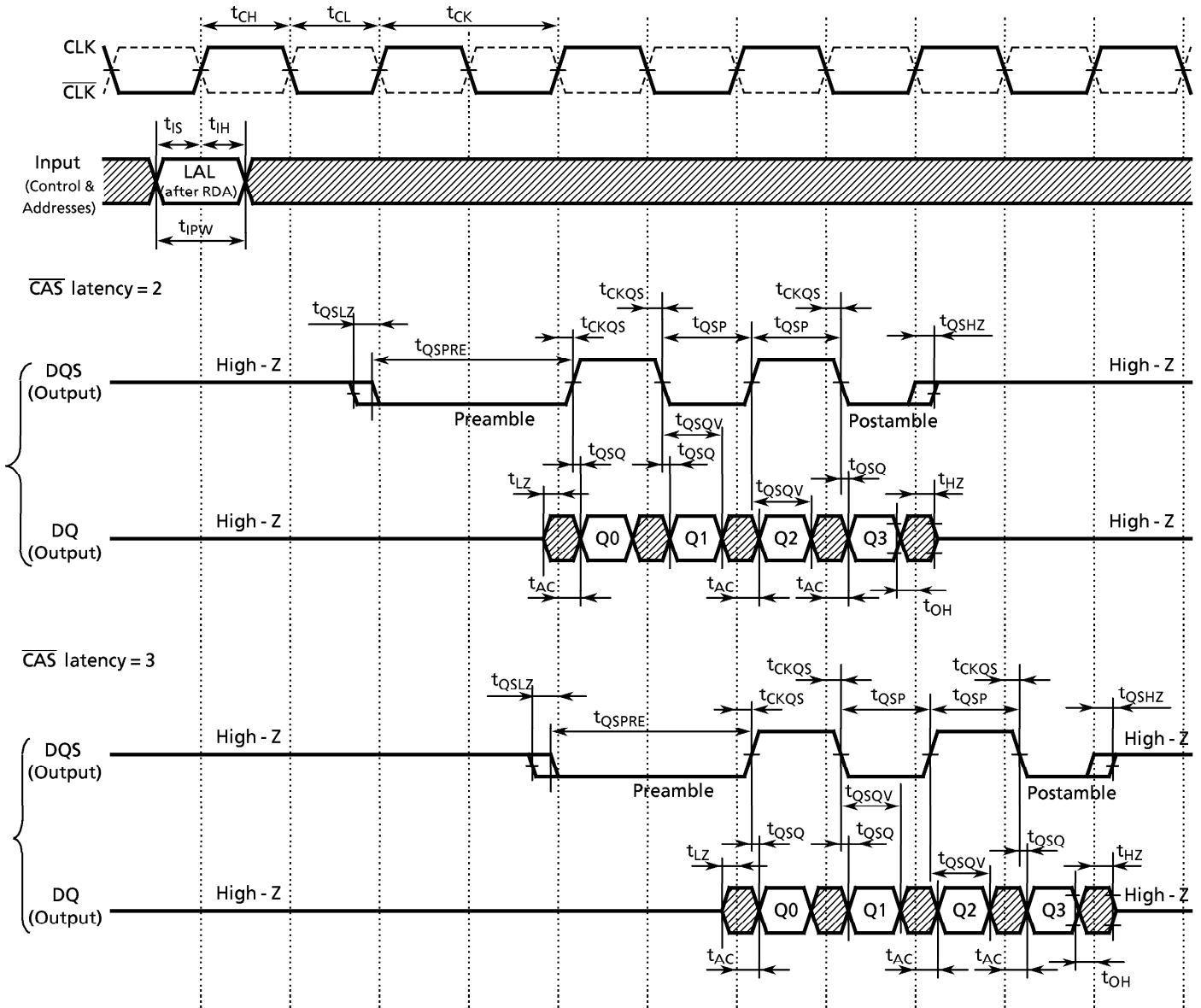

Note. The correspondence of LDQS, UDQS to DQ. (TC59LM814BFT)

LDQS	DQ0 to 7
UDQS	DQ8 to 15

Write Timing (x16 device) (Burst Length=4)

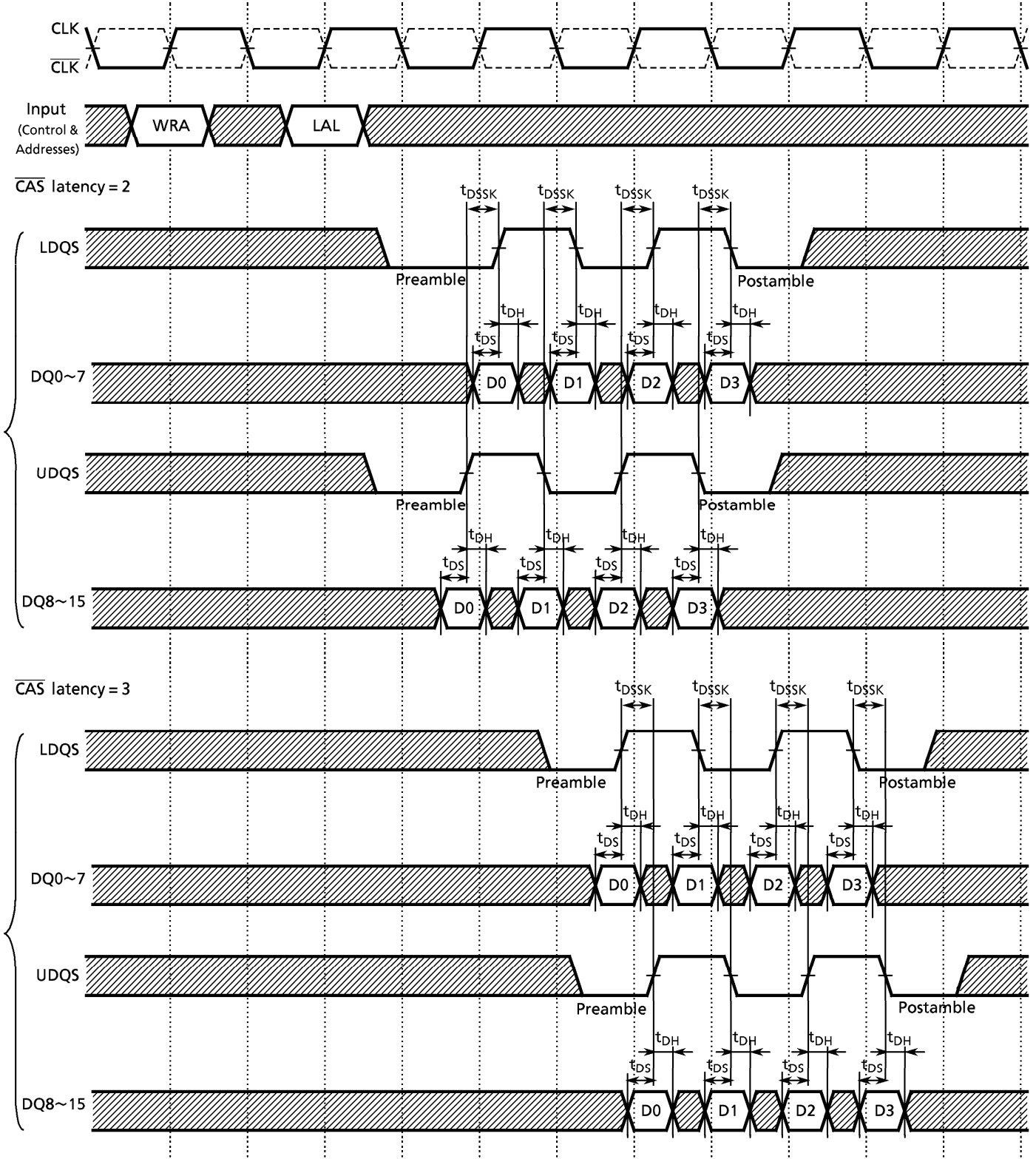

Note: x16 has 2 DQS's (UDQS for upper byte and LDQS for lower byte).
Even, if one of the 2 bytes is not used, both UDQS and LDQS must be toggled.

FUNCTION TRUTH TABLE (Notes: 1, 2, 3)

COMMAND TRUTH TABLE (Notes: 4)

• The First Command

Symbol	Function	\overline{CS}	FN	BA1-BA0	A14-A9	A8	A7	A6-A0
DESL	Device Deselect	H	x	x	x	x	x	x
RDA	Read with Auto-close	L	H	BA	UA	UA	UA	UA
WRA	Write with Auto-close	L	L	BA	UA	UA	UA	UA

• The Second Command (The next clock of RDA or WRA command)

Symbol	Function	\overline{CS}	FN	BA1-BA0	A14-A13	A12-A11	A10-A9	A8	A7	A6-A0
LAL	Lower Address Latch (x16)	H	x	x	V	V	x	x	x	LA
LAL	Lower Address Latch (x8)	H	x	x	V	x	x	x	LA	LA
REF	Auto-Refresh	L	x	x	x	x	x	x	x	x
MRS	Mode Register Set	L	x	V	L	L	L	L	V	V

- Notes: 1. L = Logic Low, H = Logic High, x = either L or H, V = Valid (Specified Value), BA = Bank Address, UA = Upper Address, LA = Lower Address
 2. All commands are assumed to issue at a valid state.
 3. All inputs for command (excluding SELFX and PDEX) are latched on the crossing point of differential clock input where CLK goes to High.
 4. Operation mode is decided by the combination of 1st command and 2nd command. Refer to "STATE DIAGRAM" and the command table below.

READ COMMAND TABLE

Command (Symbol)	\overline{CS}	FN	BA1-BA0	A14-A9	A8	A7	A6-A0	Notes
RDA (1st)	L	H	BA	UA	UA	UA	UA	
LAL (2nd)	H	x	x	x	x	LA	LA	5

Note: 5. For x16 device, A7 is "x" (either L or H).

WRITE COMMAND TABLE

TC59LM814BFT

Command (Symbol)	\overline{CS}	FN	BA1-BA0	A14	A13	A12	A11	A10-A9	A8	A7	A6-A0
WRA (1st)	L	L	BA	UA	UA	UA	UA	UA	UA	UA	UA
LAL (2nd)	H	x	x	LVW0	LVW1	UVW0	UVW1	x	x	x	LA

TC59LM806BFT

Command (Symbol)	\overline{CS}	FN	BA1-BA0	A14	A13	A12	A11	A10-A9	A8	A7	A6-A0
WRA (1st)	L	L	BA	UA	UA	UA	UA	UA	UA	UA	UA
LAL (2nd)	H	x	x	VW0	VW1	x	x	x	x	LA	LA

Note : 6 A14 to A11 are used for Variable Write Length (VW) control at Write Operation.

VW TRUTH TABLE

	Function	VW0	VW1
BL = 2	Write All Words	L	x
	Write First One Word	H	x
BL = 4	Reserved	L	L
	Write All Words	H	L
	Write First Two Words	L	H
	Write First One Word	H	H

Note: 7 For x16 device, LVW0 and LVW1 control DQ0-DQ7.
UVW0 and UVW1 control DQ8-DQ15.

MODE REGISTER SET COMMAND TABLE

Command (Symbol)	\overline{CS}	FN	BA1-BA0	A14-A9	A8	A7	A6-A0	Notes
RDA (1st)	L	H	x	x	x	x	x	
MRS (2nd)	L	x	V	L	L	V	V	8

Note: 8. Refer to "MODE REGISTER TABLE".

FUNCTION TRUTH TABLE (Continued)

AUTO-REFRESH COMMAND TABLE

Function	Command (Symbol)	Current State	\overline{PD}		\overline{CS}	FN	BA1-BA0	A14-A9	A8	A7	A6-A0	Notes
			n-1	n								
Active	WRA (1st)	Standby	H	H	L	L	x	x	x	x	x	
Auto-Refresh	REF (2nd)	Active	H	H	L	x	x	x	x	x	x	

SELF-REFRESH COMMAND TABLE

Function	Command (Symbol)	Current State	\overline{PD}		\overline{CS}	FN	BA1-BA0	A14-A9	A8	A7	A6-A0	Notes
			n-1	n								
Active	WRA (1st)	Standby	H	H	L	L	x	x	x	x	x	
Self-Refresh Entry	REF (2nd)	Active	H	L	L	x	x	x	x	x	x	9, 10
Self-Refresh Continue	-	Self-Refresh	L	L	x	x	x	x	x	x	x	
Self-Refresh Exit	SELFEX	Self-Refresh	L	H	H	x	x	x	x	x	x	11

POWER DOWN TABLE

Function	Command (Symbol)	Current State	\overline{PD}		\overline{CS}	FN	BA1-BA0	A14-A9	A8	A7	A6-A0	Notes
			n-1	n								
Power Down Entry	PDEN	Standby	H	L	H	x	x	x	x	x	x	10
Power Down Continue	-	Power Down	L	L	x	x	x	x	x	x	x	
Power Down Exit	PDEX	Power Down	L	H	H	x	x	x	x	x	x	11

- Notes: 9. \overline{PD} has to be brought to Low within t_{FPDL} from REF command.
 10. \overline{PD} should be brought to Low after DQ's state turned high impedance.
 11. When \overline{PD} is brought to High from Low, this function is executed asynchronously.

FUNCTION TRUTH TABLE (Continued)

Current state	PD		\overline{CS}	FN	Address	Command	Action	Notes
	n-1	n						
Idle	H	H	H	x	x	DESL	NOP	
	H	H	L	H	BA, UA	RDA	Row activate for Read	
	H	H	L	L	BA, UA	WRA	Row activate for Write	
	H	L	H	x	x	PDEN	Power Down Entry	12
	H	L	L	x	x	—	Illegal	
Row Active for Read	L	x	x	x	x	—	Refer to Power Down state	
	H	H	H	x	LA	LAL	Begin read	
	H	H	L	x	Op-Code	MRS/EMRS	Access to Mode Register	
	H	L	H	x	x	PDEN	Illegal	
	H	L	L	x	x	REF (Self)	Illegal	
Row Active for Write	L	x	x	x	x	—	Invalid	
	H	H	H	x	LA	LAL	Begin write	
	H	H	L	x	x	REF	Auto-Refresh	
	H	L	H	x	x	PDEN	Illegal	
	H	L	L	x	x	REF (Self)	Self-Refresh entry	
Read	L	x	x	x	x	—	Invalid	
	H	H	H	x	x	DESL	Continue burst read to end	
	H	H	L	H	BA, UA	RDA	Illegal	13
	H	H	L	L	BA, UA	WRA	Illegal	13
	H	L	H	x	x	PDEN	Illegal	
Write	H	L	L	x	x	—	Illegal	
	L	x	x	x	x	—	Invalid	
	H	H	H	x	x	DESL	Data write & continue burst write to end	
	H	H	L	H	BA, UA	RDA	Illegal	13
	H	H	L	L	BA, UA	WRA	Illegal	13
Auto-Refreshing	H	L	H	x	x	PDEN	Illegal	
	H	L	L	x	x	—	Illegal	
	L	x	x	x	x	—	Refer to Self-Refreshing state	
	H	H	H	x	x	DESL	NOP→Idle after I _{REFC}	
	H	H	L	H	BA, UA	RDA	Illegal	
Mode Register Accessing	H	H	L	L	BA, UA	WRA	Illegal	
	H	L	H	x	x	PDEN	Illegal	
	H	L	L	x	x	—	Illegal	
	L	x	x	x	x	—	Invalid	
	Power Down	L	x	x	x	x	—	Invalid
L		L	x	x	x	—	Maintain Power Down Mode	
L		H	H	x	x	PDEX	Exit Power Down Mode→Idle after t _{PDEX}	
L		H	L	x	x	—	Illegal	
Self-Refreshing	L	H	L	x	x	—	Illegal	
	L	L	x	x	x	—	Maintain Self-Refresh	
	L	H	H	x	x	SELFX	Exit Self-Refresh→Idle after I _{REFC}	
	L	H	L	x	x	—	Illegal	

Notes: 12. Illegal if any bank is not idle.
 13. Illegal to bank in specified states; Function may be legal in the bank indicated by Bank Address (BA).
 14. Illegal if tFPDL is not satisfied.

MODE REGISTER TABLE

Regular Mode Register (Notes : 1)

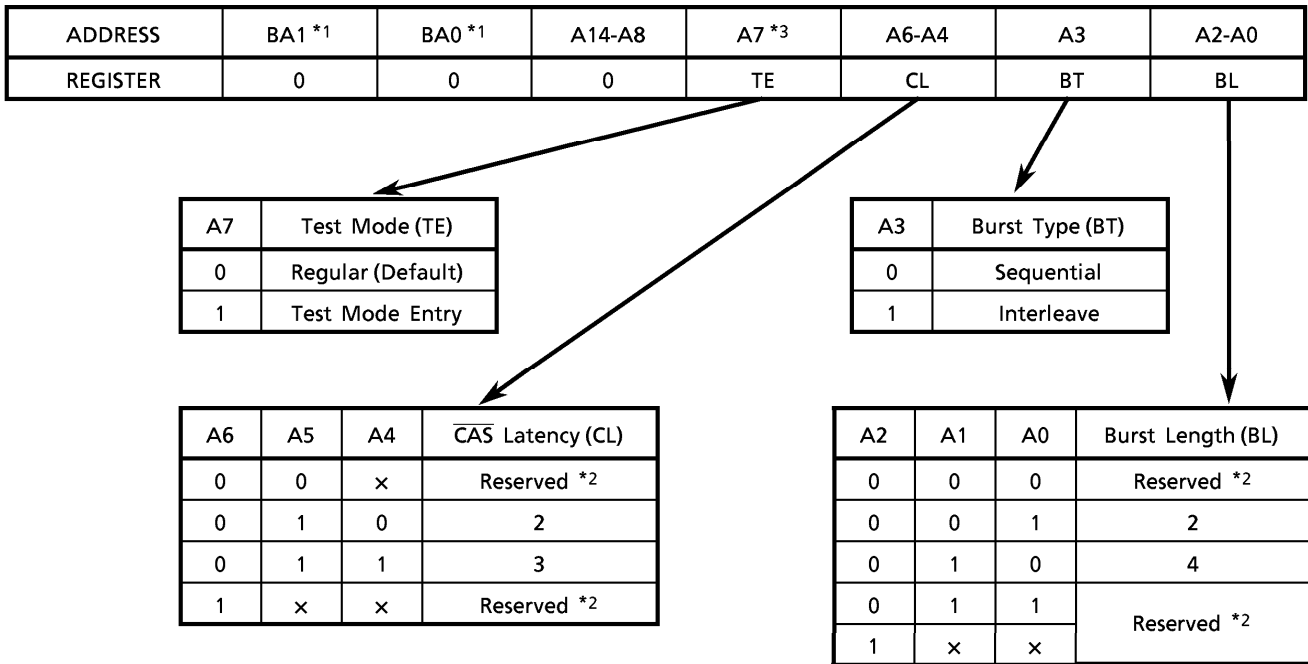

Extended Mode Register (Notes : 4)

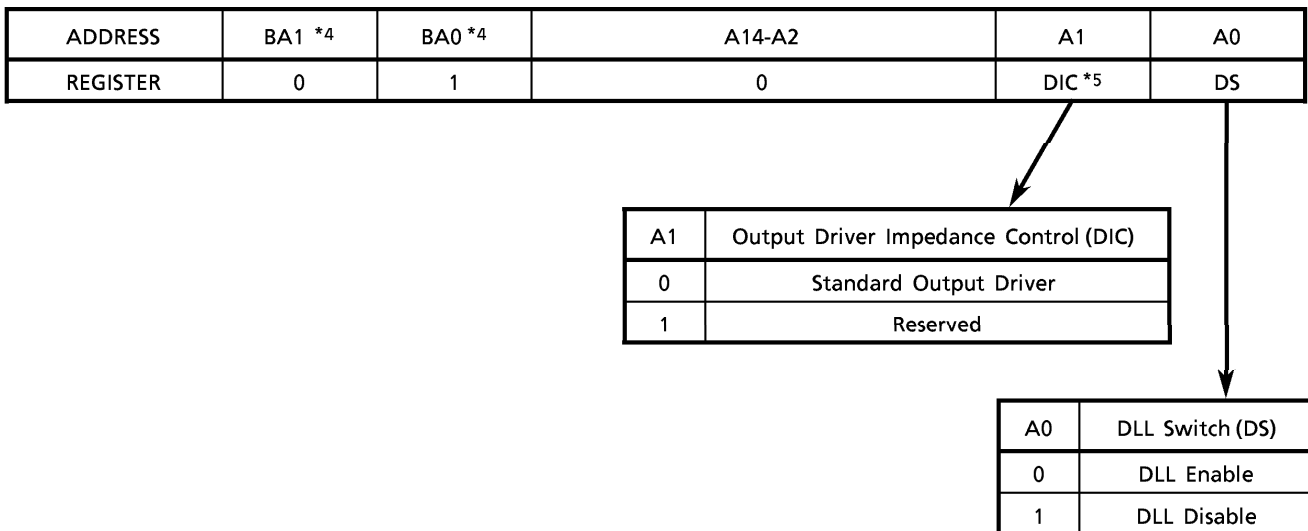

- Notes:
1. Regular Mode Register is chosen using the combination of BA0=0 and BA1=0.
 2. "Reserved" places in Regular Mode Register should not be set.
 3. A7 in Regular Mode Register must be set to "0"(Low state).
Because Test Mode is specific mode for supplier.
 4. Extended Mode Register is chosen using the combination of BA0=1 and BA1=0.
 5. A1 in Extended Mode Register must be set to "0" (Low state).

STATE DIAGRAM

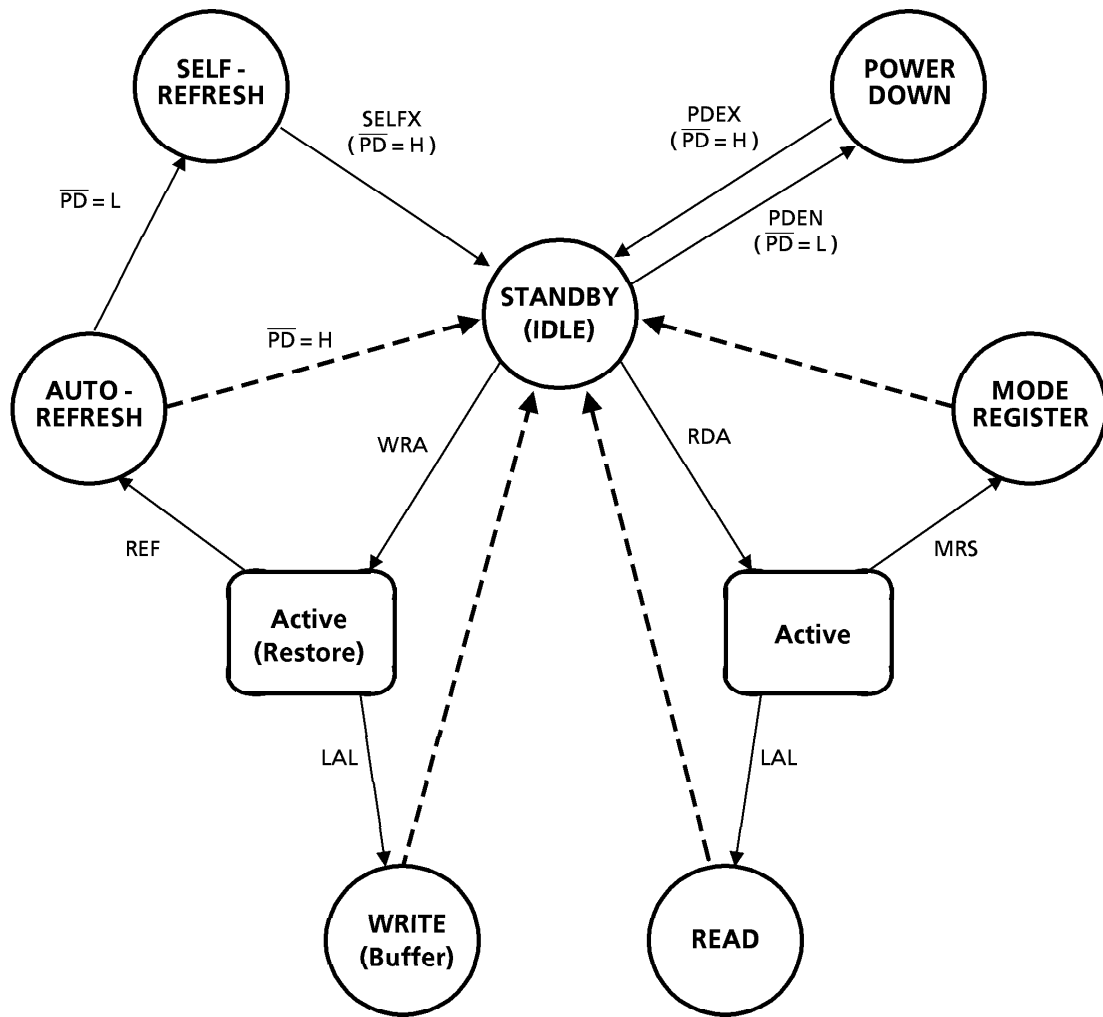

———→ Command Input
 - - - -> Automatic Return

The second command at Active state must be issued 1 clock after RDA or WRA command input.

TIMING DIAGRAMS

Single Bank Read Timing (CL=2)

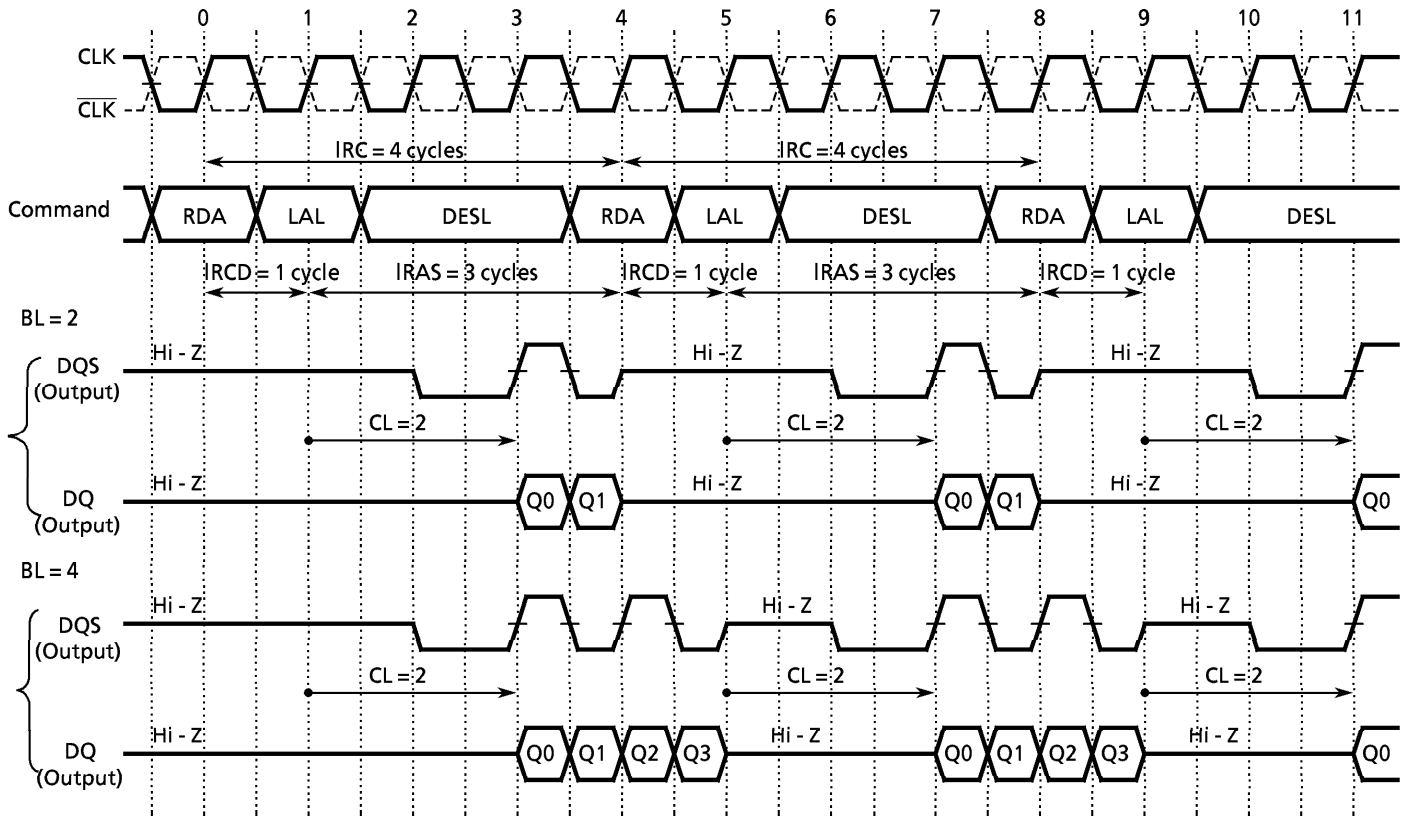

Single Bank Read Timing (CL=3)

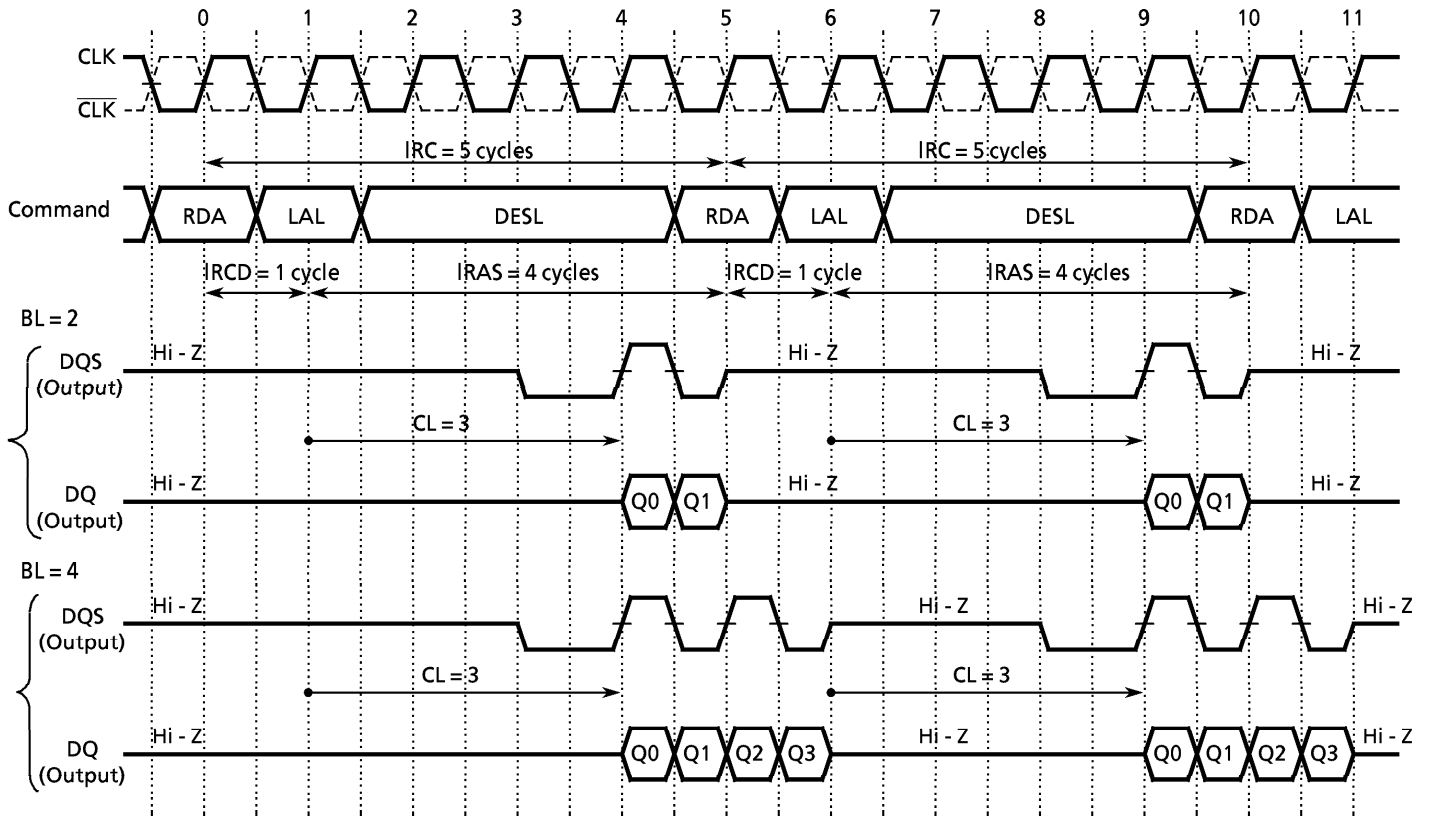

Single Bank Write Timing (CL=2)

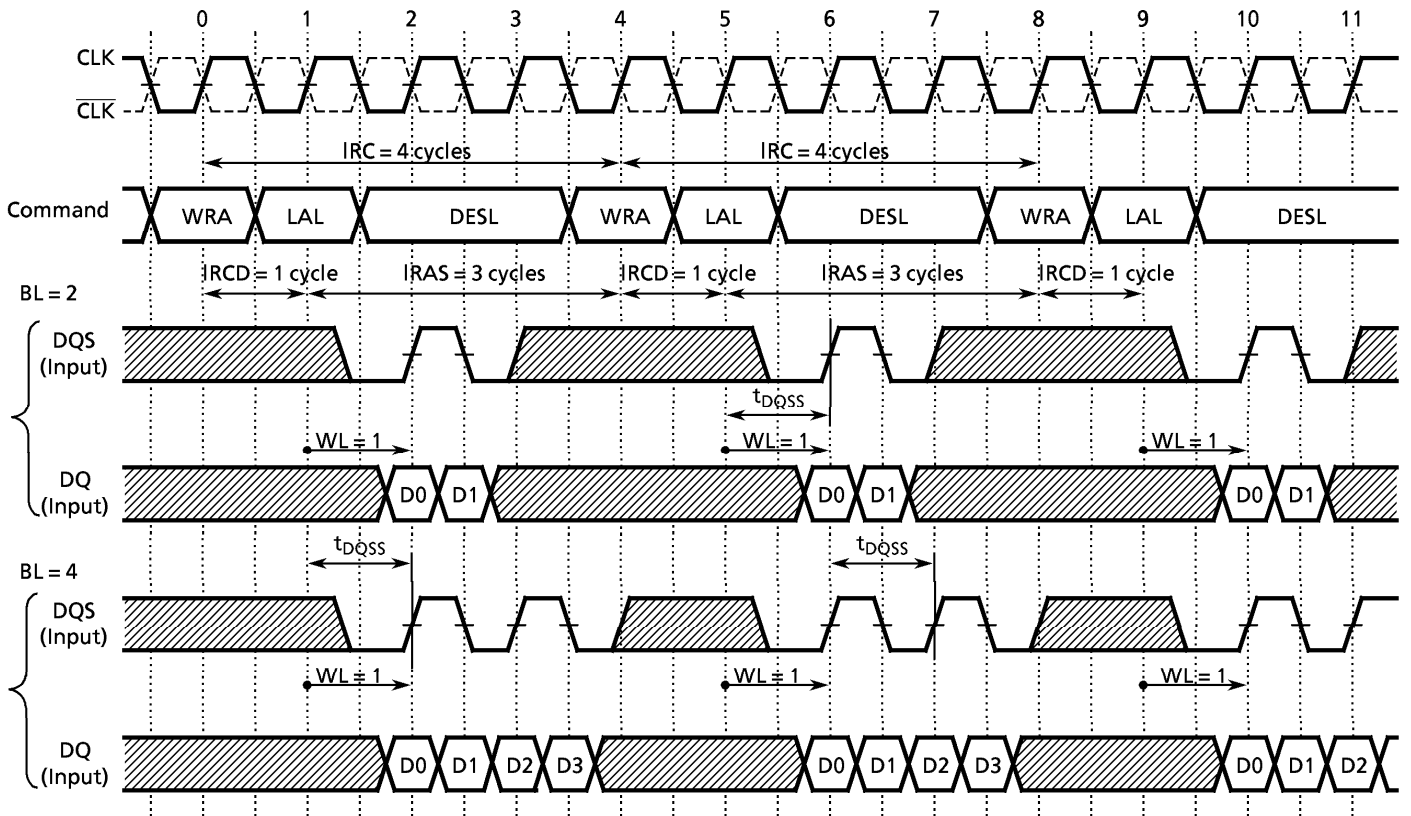

Single Bank Write Timing (CL=3)

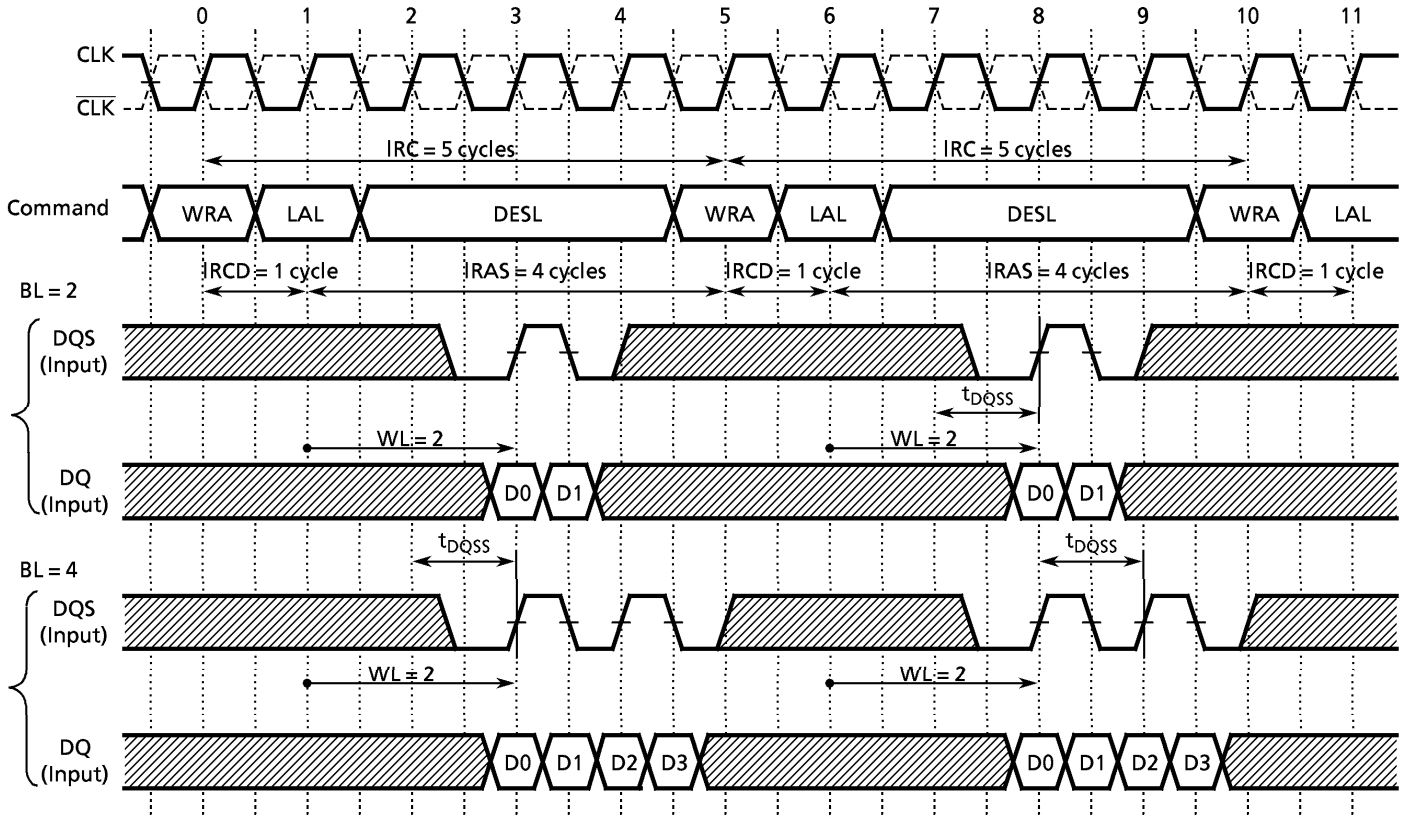

Note:  means "H" or "L"

Single Bank Read-Write Timing (CL=2)

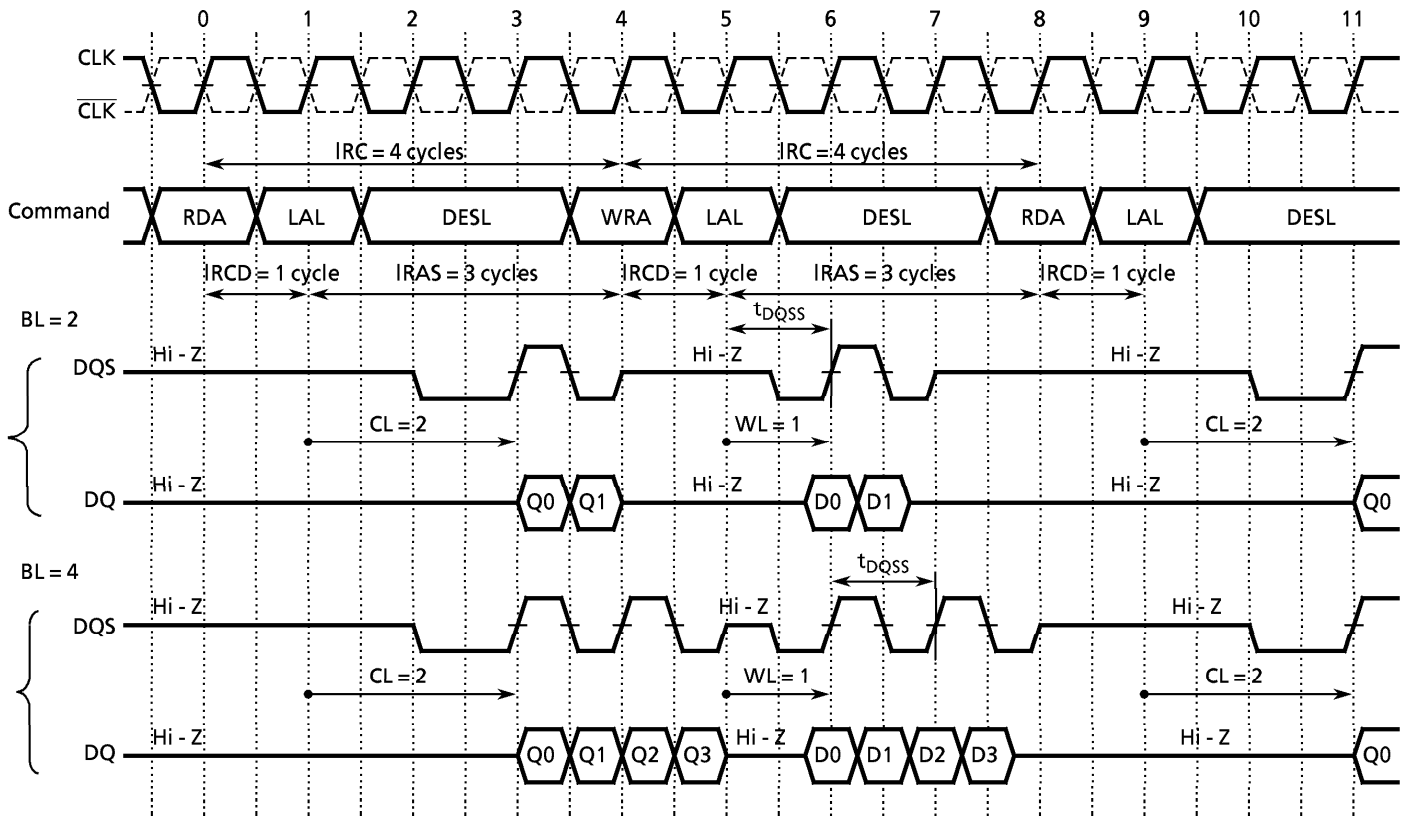

Single Bank Read-Write Timing (CL=3)

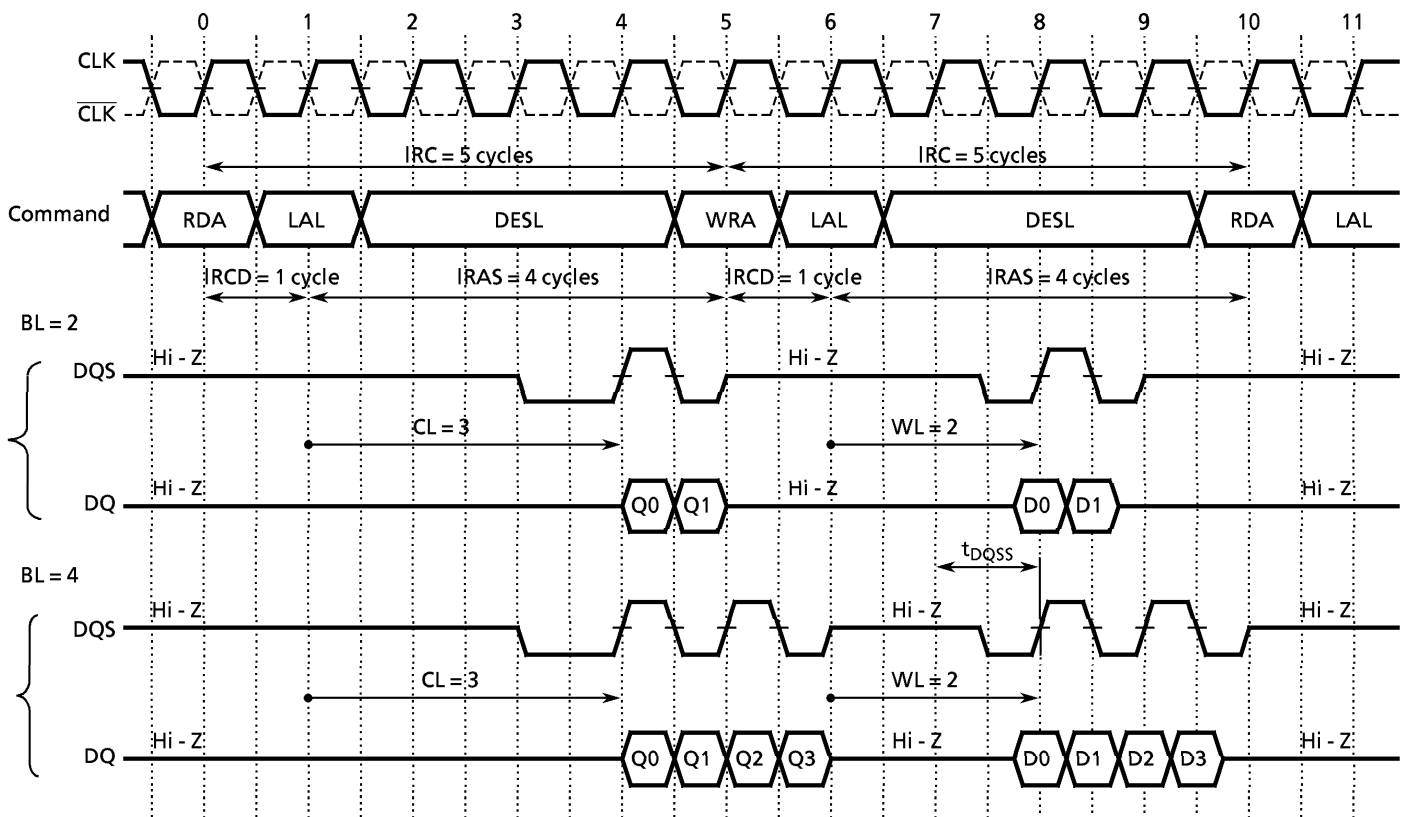

Multiple Bank Read Timing (CL=2)

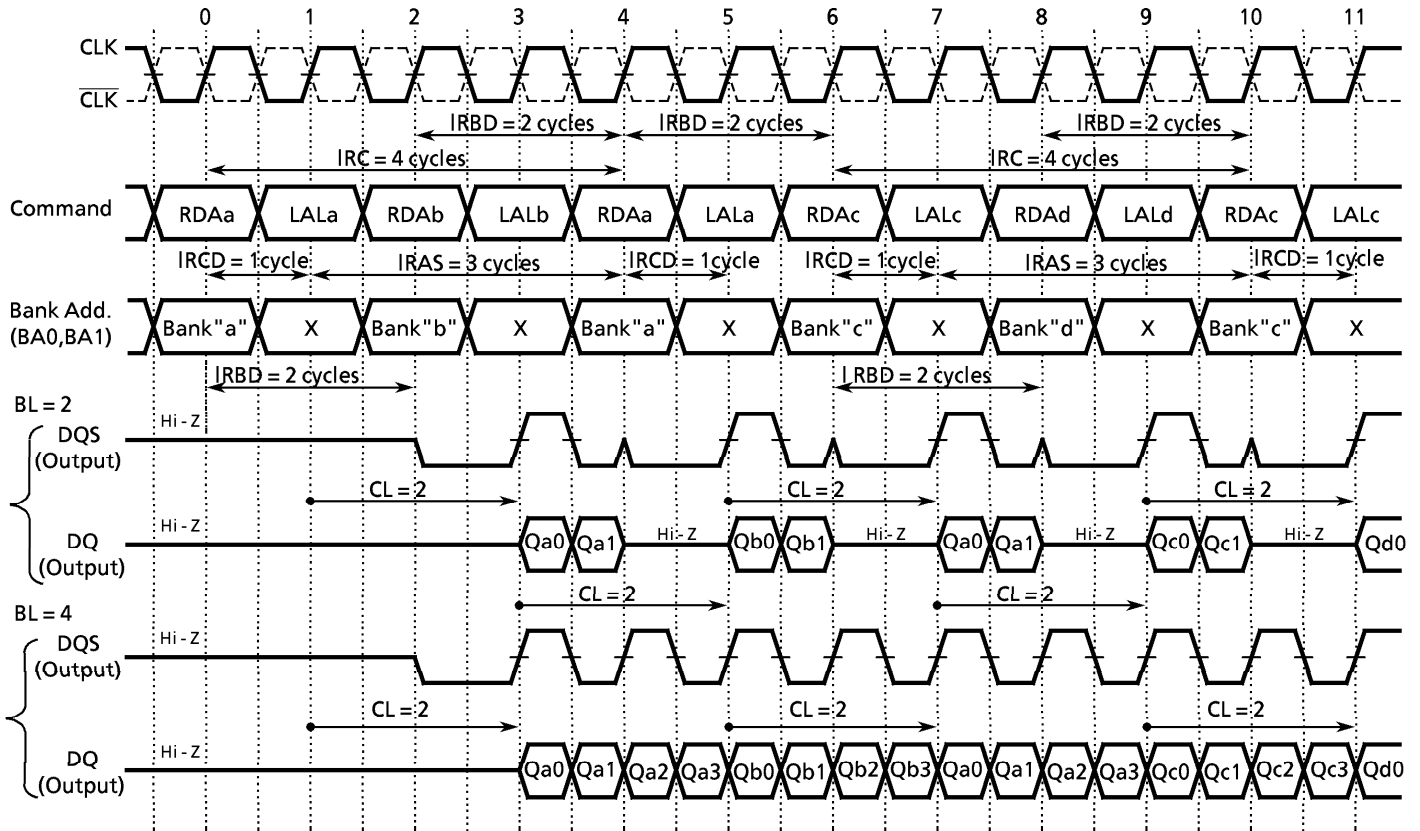

Multiple Bank Read Timing (CL=3)

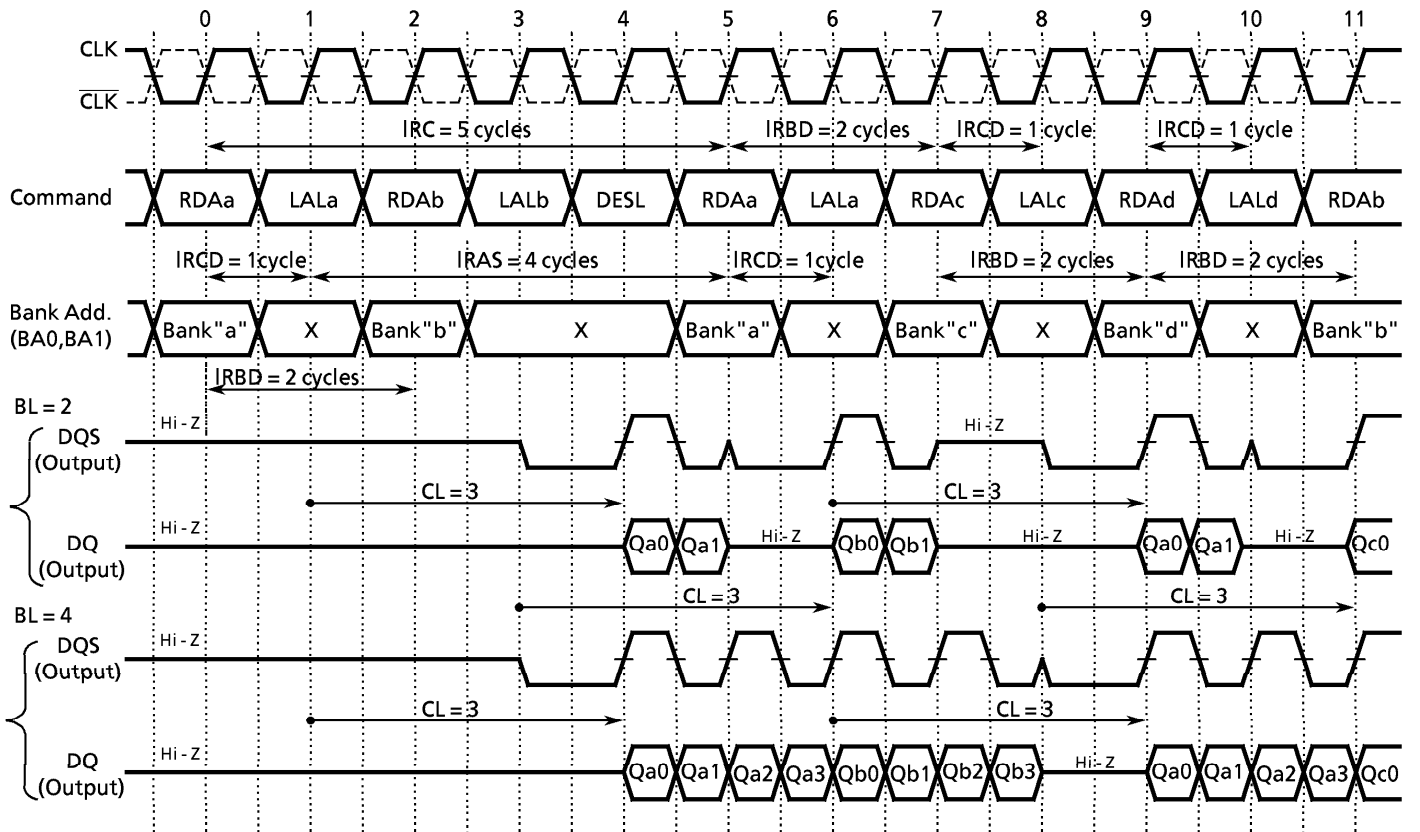

Note: "X" is don't care.
IRC to the same bank must be satisfied.

Multiple Bank Write Timing (CL=2)

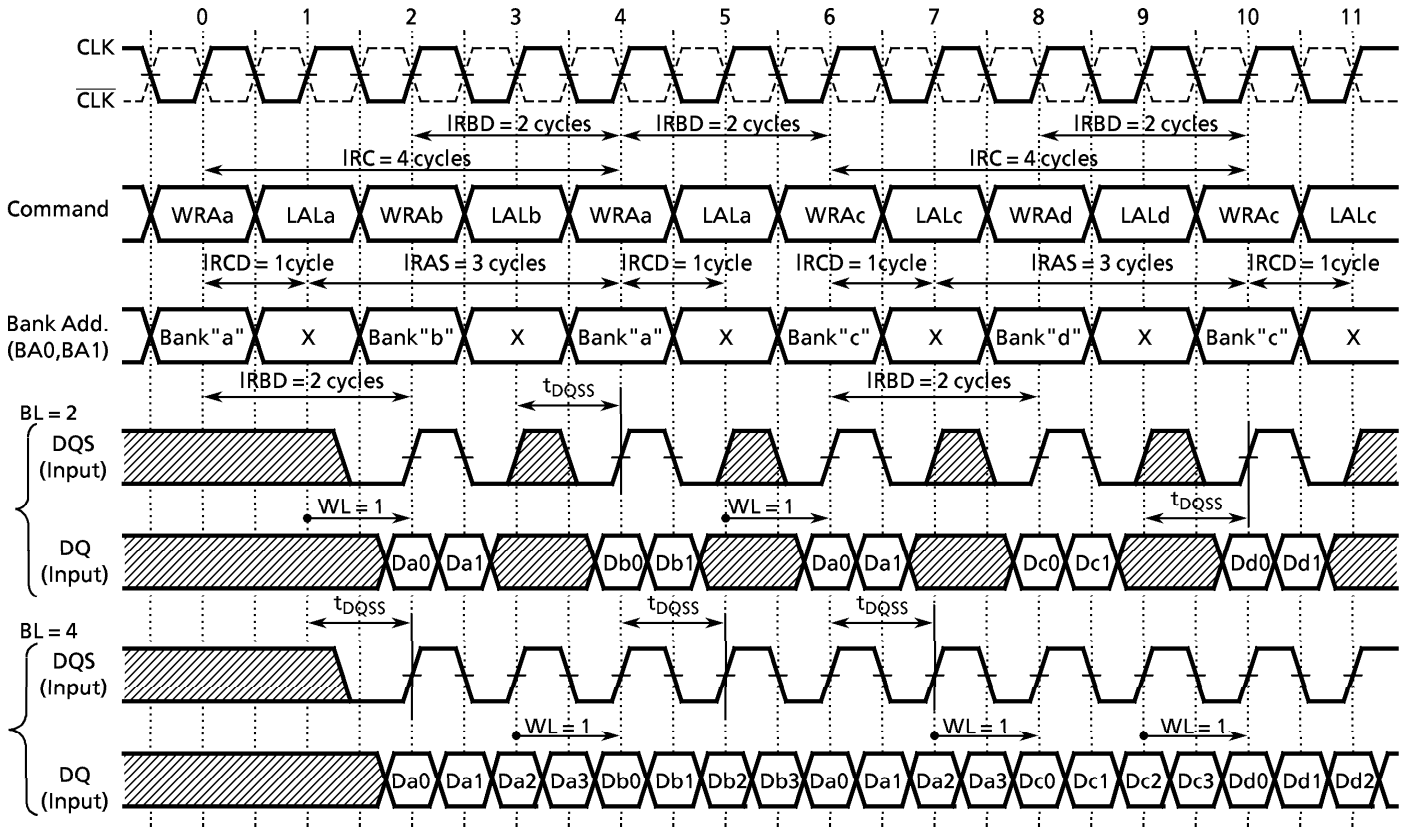

Multiple Bank Write Timing (CL=3)

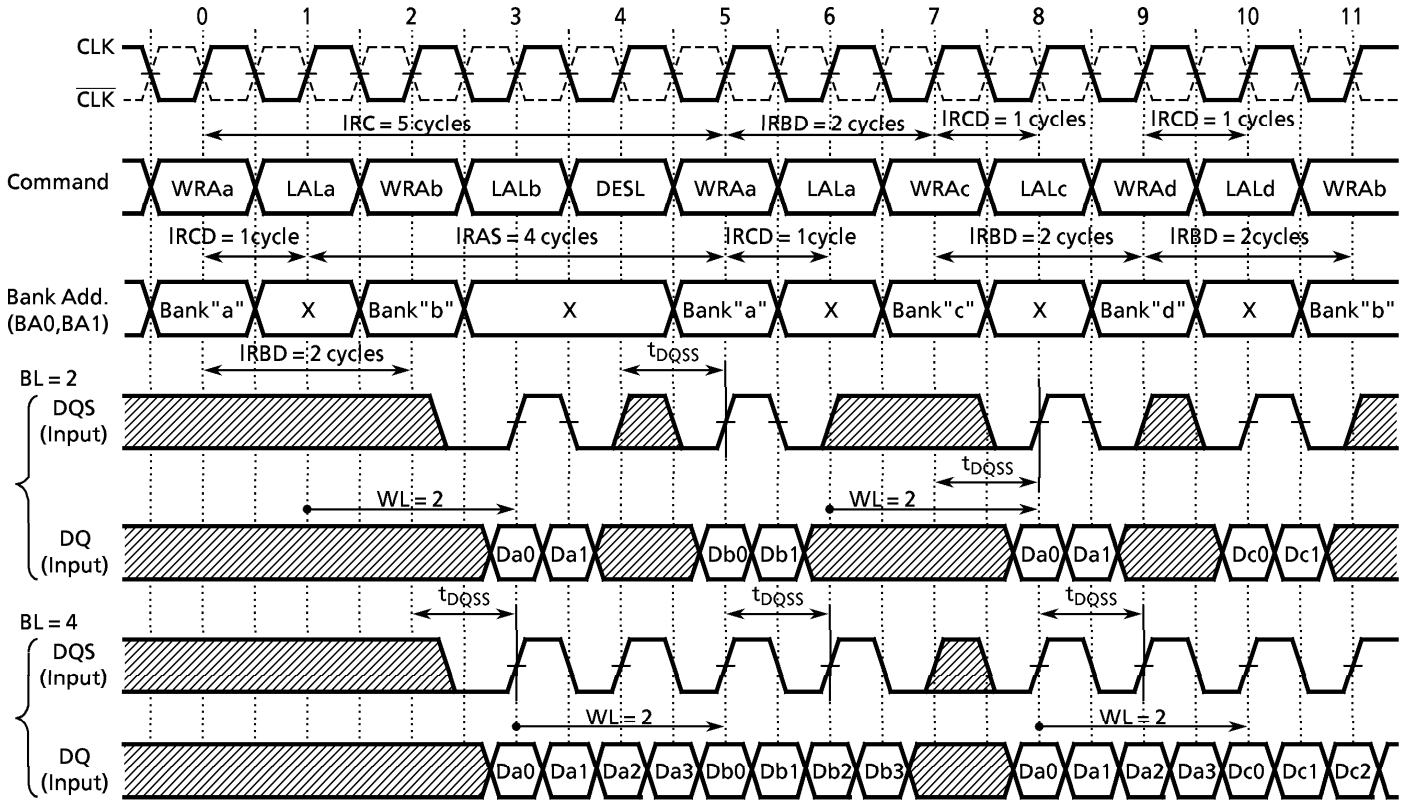

Note: means "H" or "L".
 "X" is don't care
 IRC to the same bank must be satisfied.

Multiple Bank Read-Write Timing (BL=2)

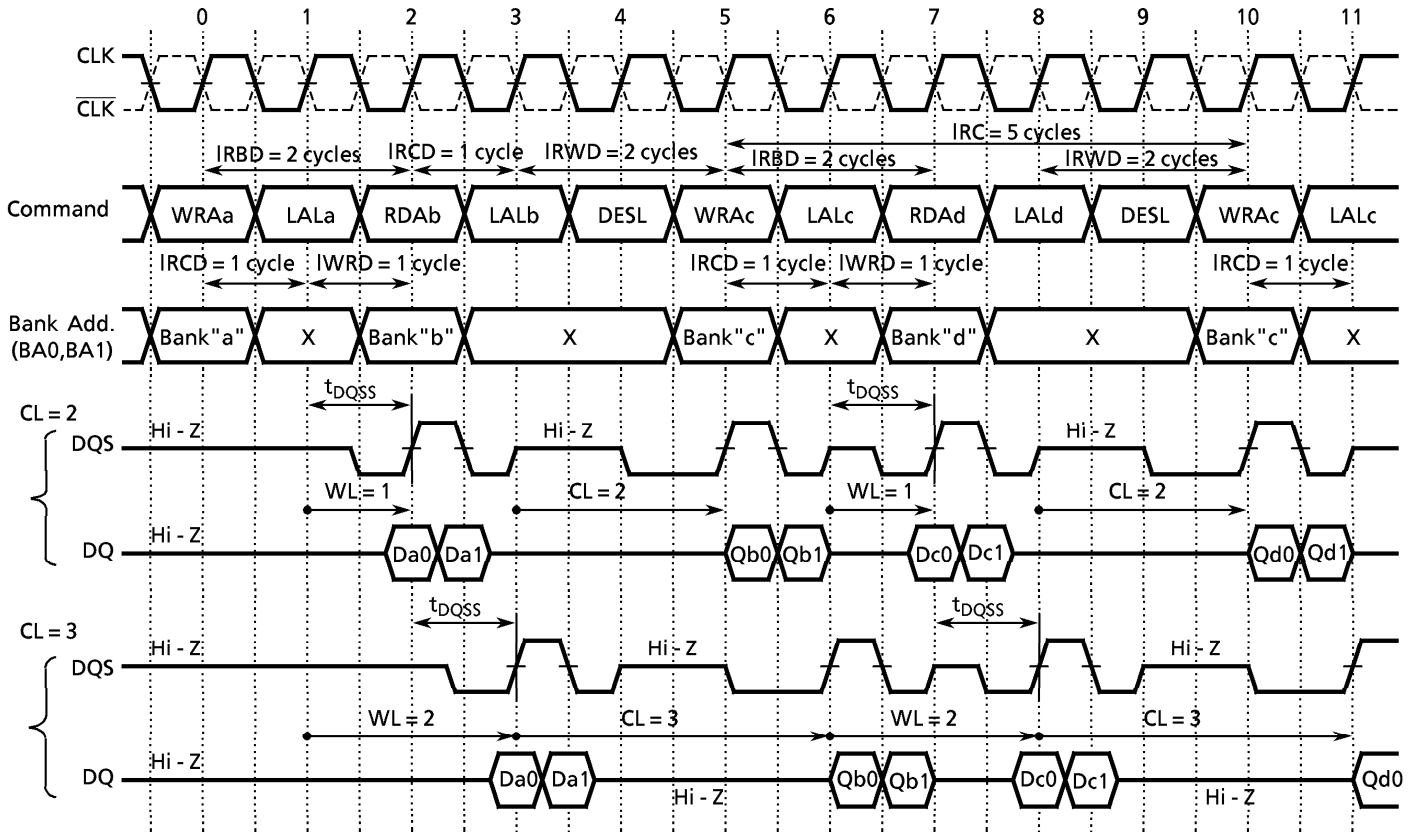

Multiple Bank Read-Write Timing (BL=4)

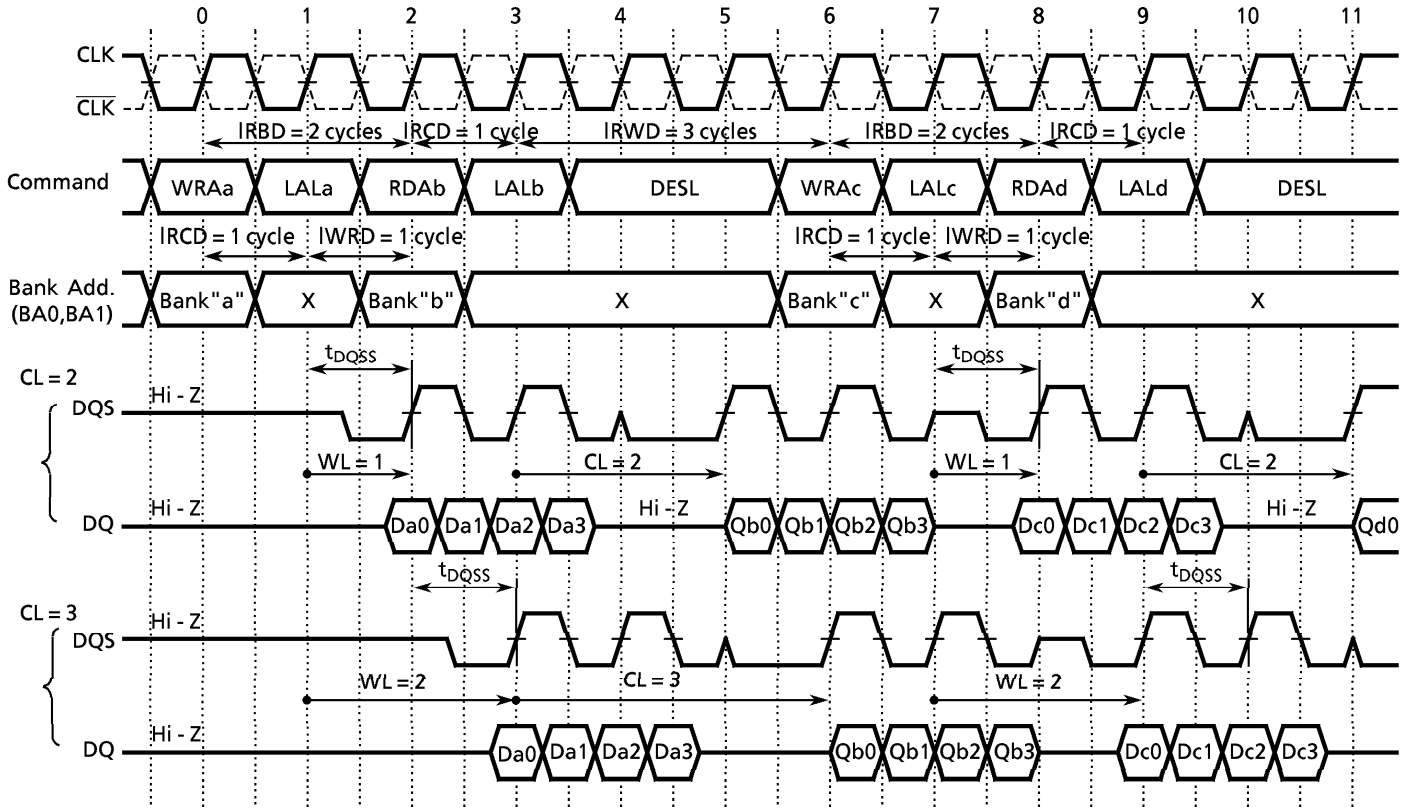

Note: "X" is don't care
IRC to the same bank must be satisfied.

Single Bank Write with VW (CL=3, BL=4)

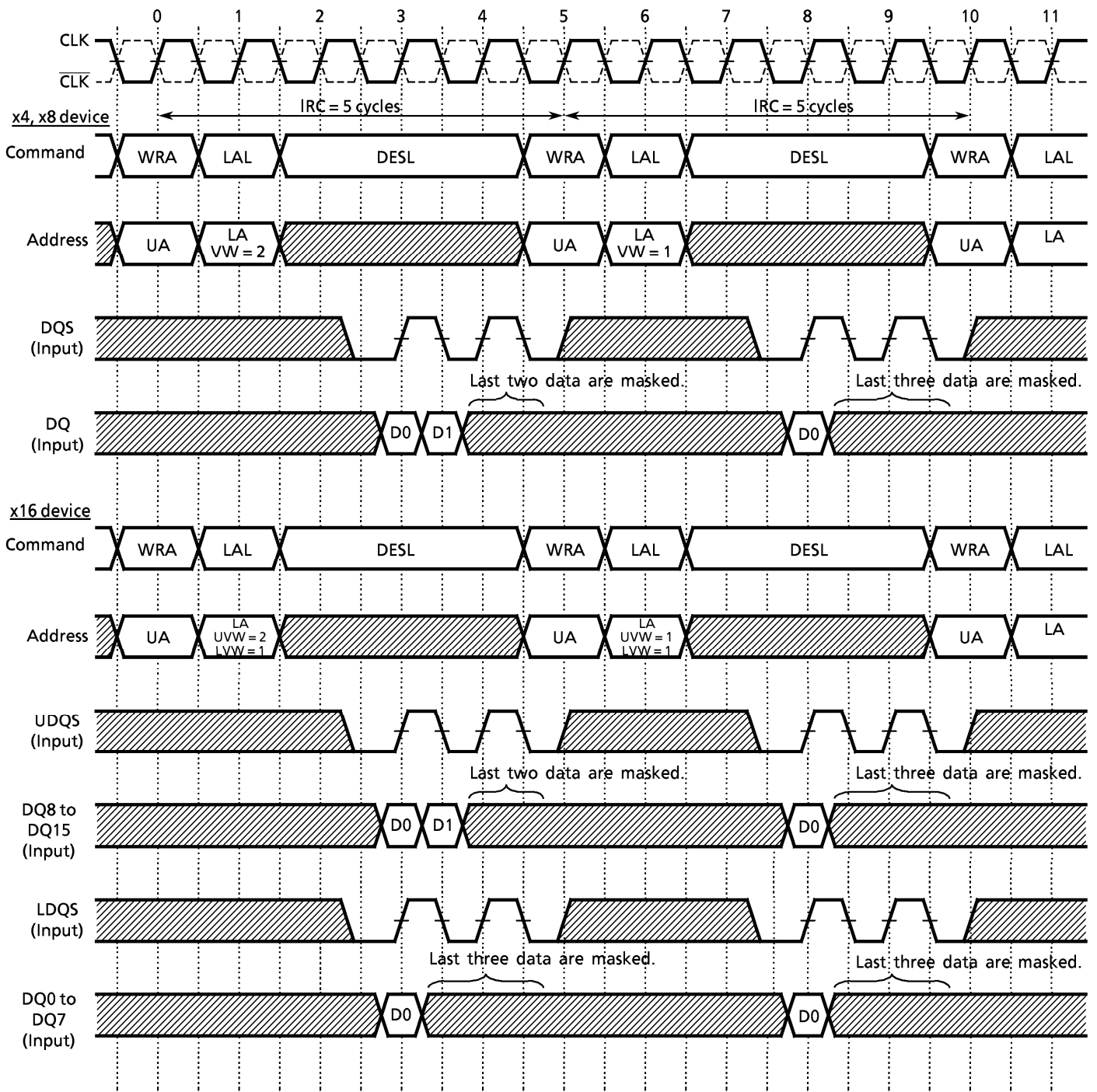

Notes : DQS input must be continued till end of burst count even if some of later data is masked.

Mode Register Set Timing (CL=2, BL=2)

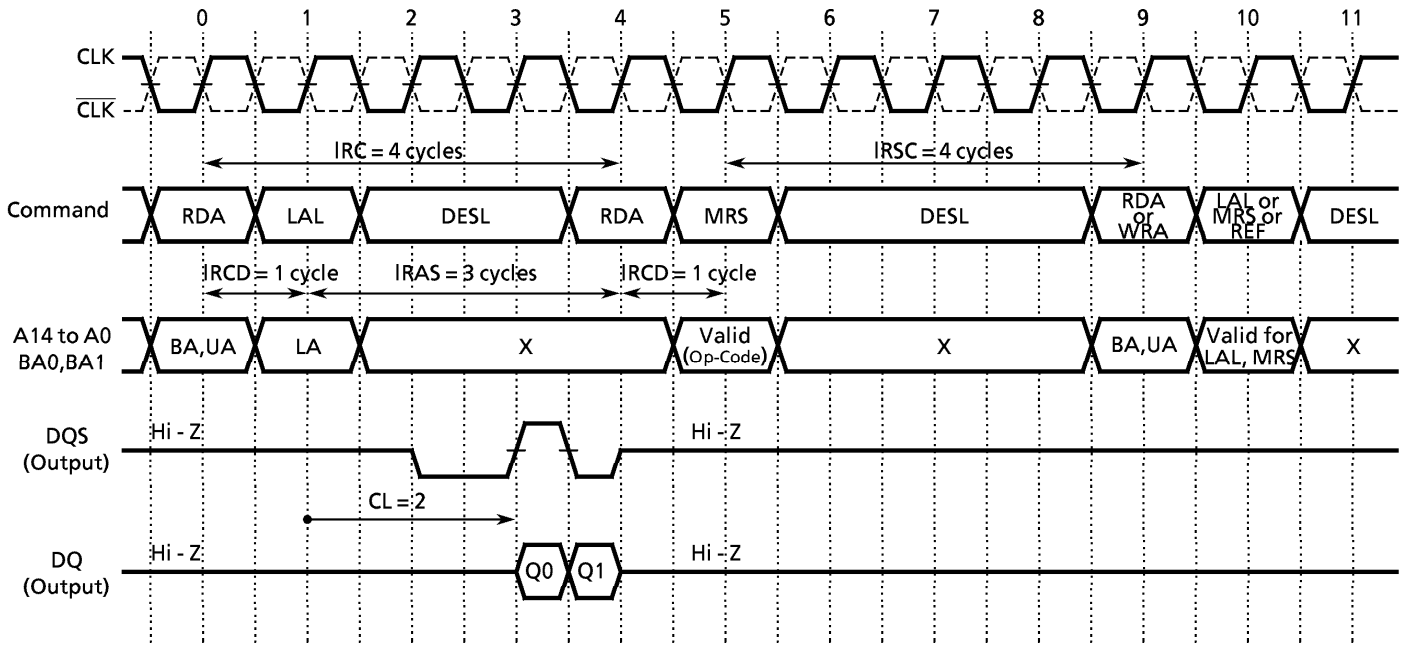

Power Down Timing (CL=2, BL=2)

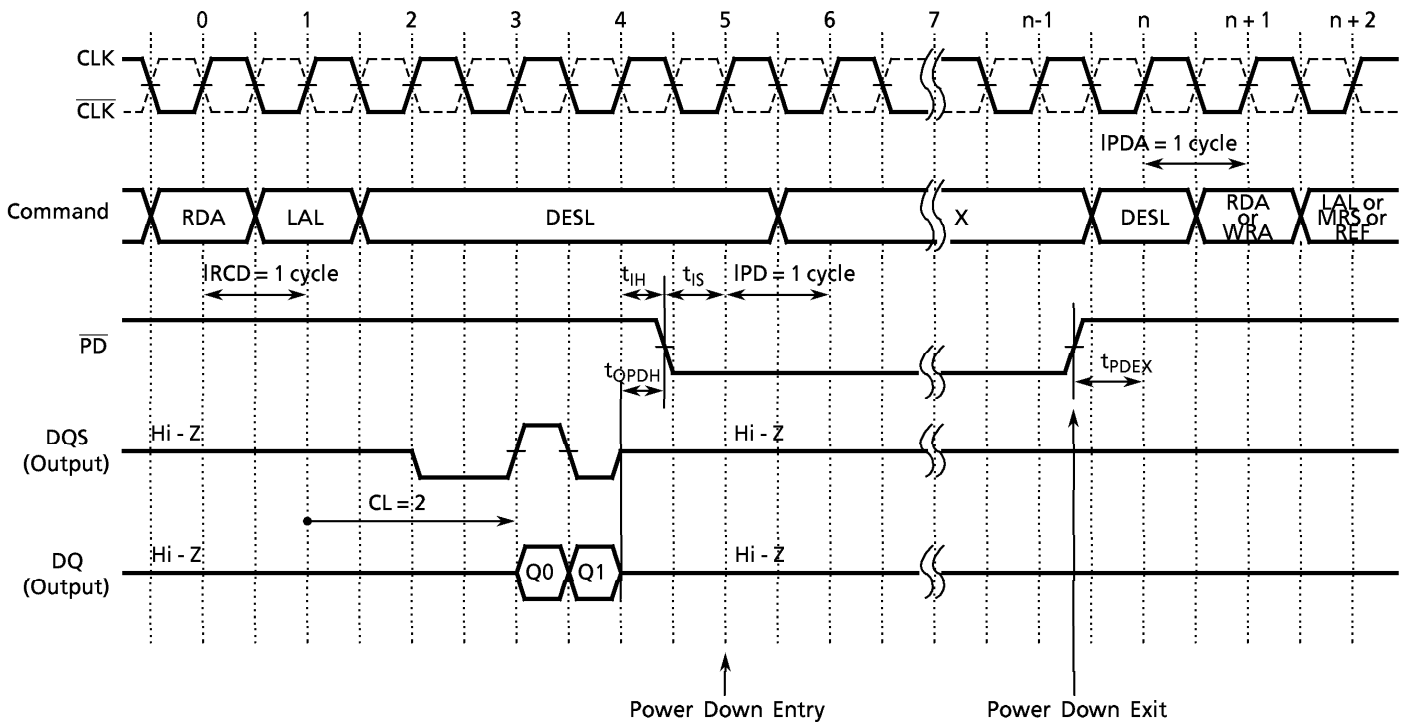

Note: "X" is don't care.

IPD is defined from the first clock rising edge after \overline{PD} is brought to "Low".

IPDA is defined from the first clock rising edge after \overline{PD} is brought to "High".

Auto-Refresh Timing (CL=2, BL=4)

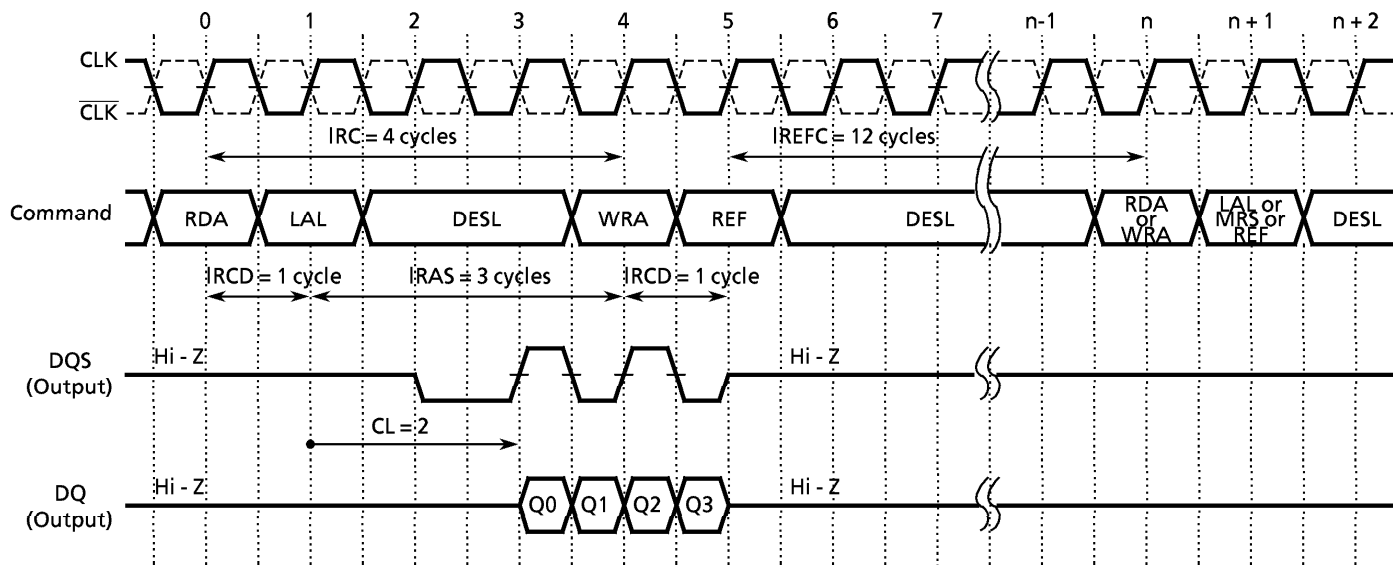

Note : In case of CL=3, IREFC must meet 15 clock cycles.

When the Auto-Refresh operation is performed, the synthetic average interval of Auto-Refresh command specified by t_{REFI} must be satisfied.

t_{REFI} is average interval time in 8 Refresh cycles that is sampled randomly.

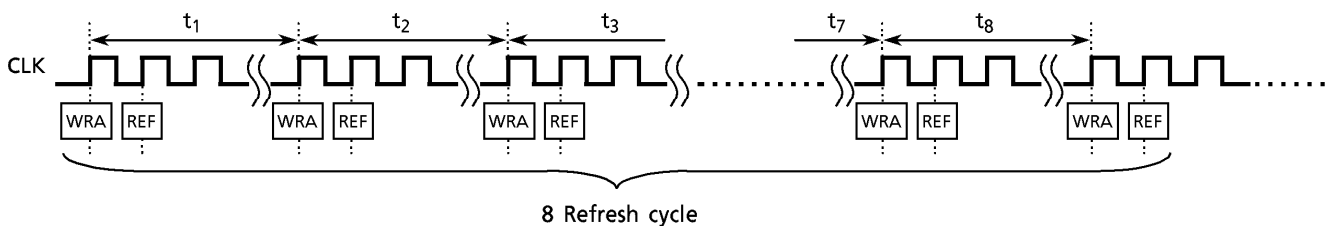

$$t_{REFI} = \frac{\text{Total time of 8 Refresh cycle}}{8} = \frac{t_1 + t_2 + t_3 + t_4 + t_5 + t_6 + t_7 + t_8}{8}$$

t_{REFI} is specified to avoid partly concentrated current of Refresh operation that is activated larger area than Read/Write operation.

Self-Refresh Entry Timing

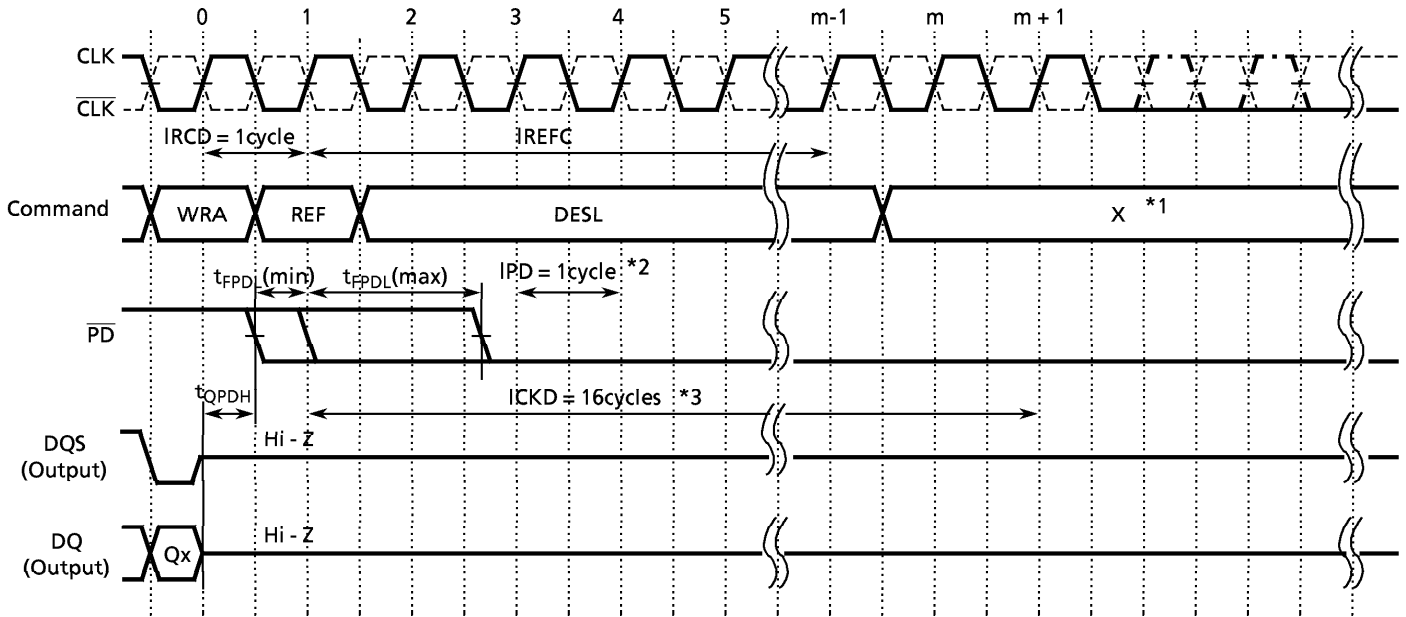

- Note: 1. "X" is don't care.,
 2. IPD is defined from the first clock rising edge after \overline{PD} is brought to "Low".
 3. Clock input has to be continued at least 16 clock cycles from REF command even though \overline{PD} is brought to "Low" for Self-Refresh Entry.

Self-Refresh Exit Timing

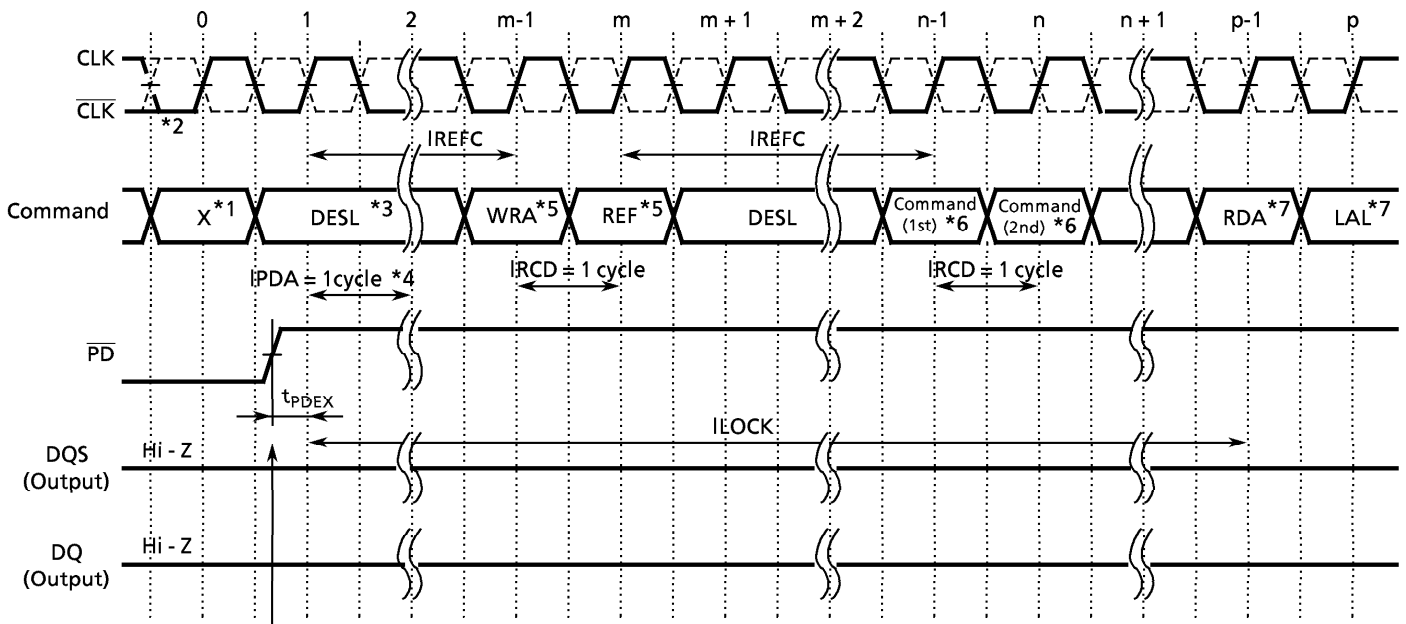

Self-Refresh Exit

- Note: 1. "X" is don't care.
 2. Clock should be stable prior to \overline{PD} = "High" if clock input is suspended in Self-Refresh mode.
 3. DESL command must be asserted during IREFC after \overline{PD} is brought to "High".
 4. IPDA is defined from the first clock rising edge after \overline{PD} is brought to "High".
 5. It is desirable that one Auto-Refresh command is issued just after Self-Refresh Exit before any other operation.
 6. Any command (except Read command) can be issued after IREFC.
 7. Read command (RDA + LAL) can be issued after ILOCK.

Power-up Initialization and Reset Timing

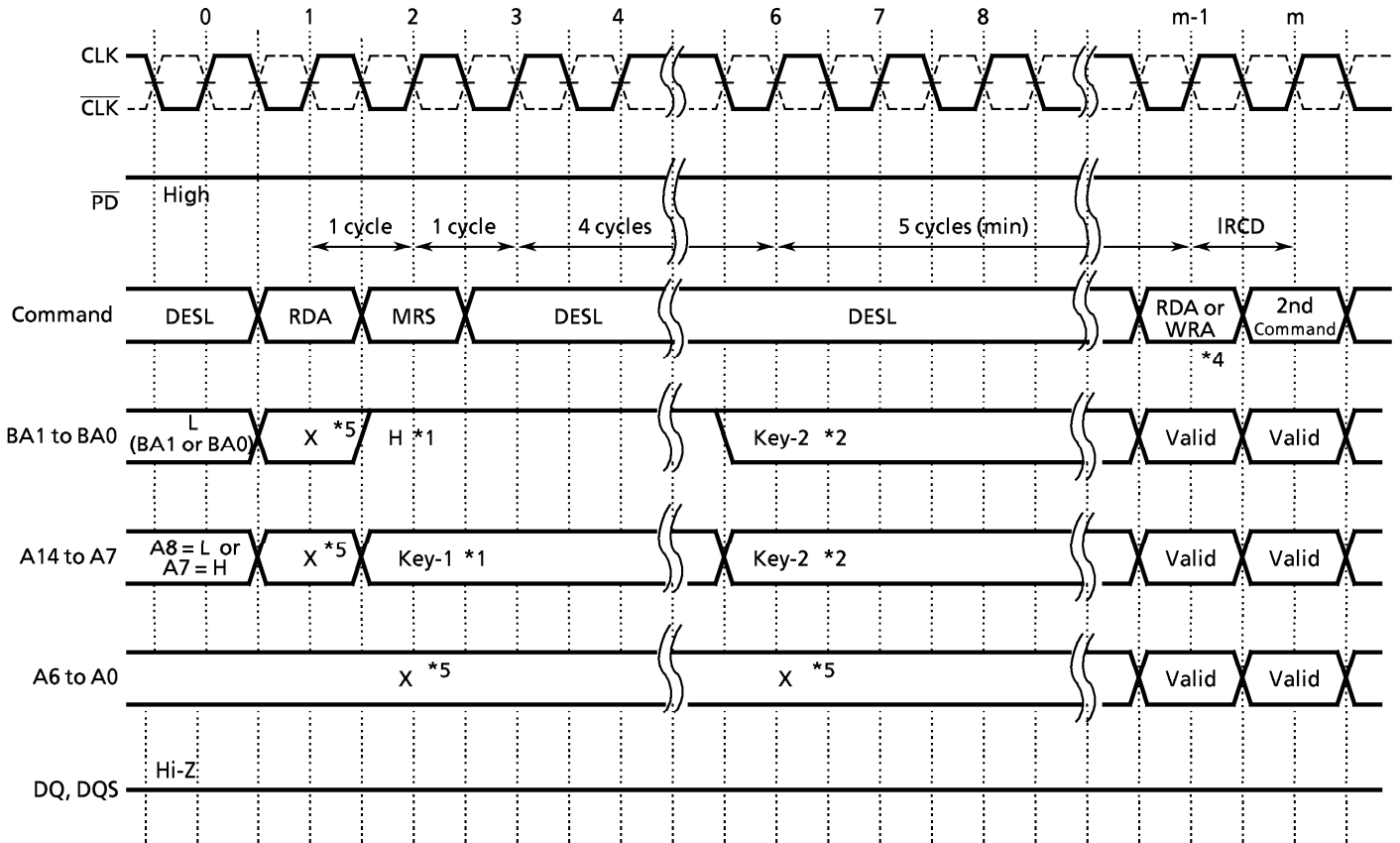

- Note :
1. BA (1-0) and A(14-8) must be High and A7 must be Low, and those value must be maintained for 4 clock cycles.
 2. At least one address must be flipped and maintained at least 5 clock cycles.
 3. DESL condition must be maintained for 12 clock cycles when RESET is being performed.
 4. Ready for normal operation after RESET or start MRS programming and Auto-Refresh at Power-up Initialization.
 5. "X" is don't care.

FUNCTIONAL DESCRIPTION

DDR FCRAM

The DDR FCRAM is an acronym of Double Data Rate Fast Cycle Random Access Memory. The DDR FCRAM is competent to perform fast random core access, low latency, low consumption and high-speed data bandwidth.

PIN FUNCTIONS

CLOCK INPUTS: CLK & $\overline{\text{CLK}}$

The CLK and $\overline{\text{CLK}}$ inputs are used as the reference for synchronous operation. CLK is master clock input. The $\overline{\text{CS}}$, FN and all address input signals are sampled on the crossing of the positive edge of CLK and the negative edge of $\overline{\text{CLK}}$. The DQS and DQ output data are referenced to the crossing point of CLK and $\overline{\text{CLK}}$. The timing reference point for the differential clock is when the CLK and $\overline{\text{CLK}}$ signals cross during a transition.

POWER DOWN: $\overline{\text{PD}}$

The $\overline{\text{PD}}$ input controls the entry to the Power Down or Self-Refresh modes. The $\overline{\text{PD}}$ input does not have a Clock Suspend function like a CKE input of a standard SDRAMs, therefore it is illegal to bring $\overline{\text{PD}}$ pin into low state if any Read or Write operation is being performed.

CHIP SELECT & FUNCTION CONTROL: $\overline{\text{CS}}$ & FN

The $\overline{\text{CS}}$ and FN inputs are a control signal for forming the operation commands on FCRAM. Each operation mode is decided by the combination of the two consecutive operation commands using the $\overline{\text{CS}}$ and FN inputs.

BANK ADDRESSES: BA0 & BA1

The BA0 and BA1 inputs are latched at the time of assertion of the RDA or WRA command and are selected the bank to be used for the operation.

	BA0	BA1
Bank #0	0	0
Bank #1	1	0
Bank #2	0	1
Bank #3	1	1

FUNCTIONAL DESCRIPTION (Continued)**ADDRESS INPUTS: A0 to A14**

Address inputs are used to access the arbitrary address of the memory cell array within each bank. The Upper Addresses with Bank addresses are latched at the RDA or WRA command and the Lower Addresses are latched at the LAL command. The A0 to A14 inputs are also used for setting the data in the Regular or Extended Mode Register set cycle.

	Upper Address	Lower Address
TC59LM806BFT	A0 to A14	A0 to A7
TC59LM814BFT	A0 to A14	A0 to A6

DATA INPUT/OUTPUT: DQ0 to DQ7 or DQ15

The input data of DQ0 to DQ15 are taken in synchronizing with the both edges of DQS input signal. The output data of DQ0 to DQ15 are outputted synchronizing with the both edges of DQS output signal.

DATA STROBE: DQS or LDQS, UDQS

The DQS is bi-directional signal. Both edges of DQS are used as the reference of data input or output. The LDQS is allotted for Lower Byte (DQ0 to DQ7) Data. The UDQS is allotted for Upper Byte(DQ8 to DQ15) Data. In write operation, the DQS used as an input signal is utilized for a latch of write data. In read operation, the DQS that is an output signal provides the read data strobe.

POWER SUPPLY: Vdd, VddQ, Vss, VssQ

Vdd and Vss are power supply pins for memory core and peripheral circuits.

VddQ and VssQ are power supply pins for the output buffer.

REFERENCE VOLTAGE: V_{REF}

V_{REF} is reference voltage for all input signals.

FUNCTIONAL DESCRIPTION (Continued)COMMAND FUNCTIONS and OPERATIONS

TC59LM814/06BFT are introduced the two consecutive command input method. Therefore, except for Power Down mode, each operation mode decided by the combination of the first command and the second command from stand-by states of the bank to be accessed.

Read Operation (1st command+2nd command=RDA+LAL)

Issuing the RDA command with Bank Addresses and Upper Addresses to the idle bank puts the bank designated by Bank Address in a read mode. When the LAL command with Lower Addresses is issued at the next clock of the RDA command, the data is read out sequentially synchronizing with the both edges of DQS output signal (Burst Read Operation). The initial valid read data appears after $\overline{\text{CAS}}$ latency from the issuing of the LAL command. The valid data is outputted for a burst length. The $\overline{\text{CAS}}$ latency, the burst length of read data and the burst type must be set in the Mode Register beforehand. The read operated bank goes back automatically to the idle state after lRC .

Write Operation (1st command+2nd command=WRA+LAL)

Issuing the WRA command with Bank Addresses and Upper Addresses to the idle bank puts the bank designated by Bank Address in a write mode. When the LAL command with Lower Addresses is issued at the next clock of the WRA command, the input data is latched sequentially synchronizing with the both edges of DQS input signal (Burst Write Operation). The data and DQS inputs have to be asserted in keeping with clock input after $\overline{\text{CAS}}$ latency-1 from the issuing of the LAL command. The write data length is set by the VW in the LAL command. The DQS have to be provided for a burst length. The $\overline{\text{CAS}}$ latency and the burst type must be set in the Mode Register beforehand. The write operated bank goes back automatically to the idle state after lRC .

Auto-Refresh Operation (1st command+2nd command=WRA+REF)

TC59LM814/06BFT are required to refresh like a standard SDRAM. The Auto-Refresh operation is begun with the REF command following to the WRA command. The Auto-Refresh mode can be effective only when all banks are in the idle state and all outputs are in Hi-Z states. In a point to notice, the write mode started with the WRA command is canceled by the REF command having gone into the next clock of the WRA command instead of the LAL command. The minimum period between the Auto-Refresh command and the next command is specified by lREFC . However, about a synthetic average interval of Auto-Refresh command, it must be careful. In case of equally distributed refresh, Auto-Refresh command has to be issued within once for every 7.8 μs by the maximum. In case of burst refresh or random distributed refresh, the average interval of eight consecutive Auto-Refresh command has to be more than 400ns always. In other words, the number of Auto-Refresh cycles which can be performed within 3.2 μs (8 x 400ns) is to 8 times in the maximum.

FUNCTIONAL DESCRIPTION (Continued)

Self-Refresh Operation (1st command+2nd command=WRA+REF with $\overline{\text{PD}}=\text{"L"}$)

It is the function of Self-Refresh operation that refresh operation can be performed automatically by using an internal timer. When all banks are in the idle state and all outputs are in Hi-Z states, the TC59LM814/06BFT become Self-Refresh mode by issuing the Self-Refresh command. $\overline{\text{PD}}$ has to be brought to "Low" within t_{FPDL} from the REF command following to the WRA command for a Self-Refresh mode entry. In order to satisfy the refresh period, the Self-Refresh entry command should be asserted within $7.8\mu\text{s}$ after the latest Auto-Refresh command. Once the device enters Self-Refresh mode, the DESL command must be continued for t_{REFC} period. In addition, it is desirable that clock input is kept in t_{CKD} period. The device is in Self-Refresh mode as long as $\overline{\text{PD}}$ held "Low". During Self-Refresh mode, all input and output buffers except for $\overline{\text{PD}}$ are disabled, therefore the power dissipation lowers. Regarding a Self-Refresh mode exit, $\overline{\text{PD}}$ has to be changed over from "Low" to "High" along with the DESL command, and the DESL command has to be continuously issued in the number of clocks specified by t_{REFC} . The Self-Refresh exit function is asynchronous operation. It is required that one Auto-Refresh command is issued to avoid the violation of the refresh period just after t_{REFC} from Self-Refresh exit.

Power Down Mode ($\overline{\text{PD}}=\text{"L"}$)

When all banks are in the idle state and all outputs are in Hi-Z states, the TC59LM814/06BFT become Power Down Mode by asserting $\overline{\text{PD}}$ is "Low". When the device enters the Power Down Mode, all input and output buffers except for $\overline{\text{PD}}$ are disabled after specified time. Therefore, the power dissipation lowers. To exit the Power Down Mode, $\overline{\text{PD}}$ has to be brought to "High" and the DESL command has to be issued at next CLK rising edge after $\overline{\text{PD}}$ goes high. The Power Down exit function is asynchronous operation.

Mode Register Set (1st command+2nd command=RDA +MRS)

When all banks are in the idle state, issuing the MRS command following to the RDA command can program the Mode Register. In a point to notice, the read mode started with the RDA command is canceled by the MRS command having gone into the next clock of the RDA command instead of the LAL command. The data to be set in the Mode Register is transferred using A0 to A14, BA0 and BA1 address inputs. The TC59LM814/06BFT have two mode registers. These are Regular and Extended Mode Register. The Regular or Extended Mode Register is chosen by BA0 and BA1 in the MRS command. The Regular Mode Register designates the operation mode for a read or write cycle. The Regular Mode Register has four function fields.

The four fields are as follows:

- (R-1) Burst Length field to set the length of burst data
- (R-2) Burst Type field to designate the lower address access sequence in a burst cycle
- (R-3) CAS Latency field to set the access time in clock cycle
- (R-4) Test Mode field to use for supplier only.

The Extended Mode Register has two function fields.

The two fields are as follows:

- (E-1) DLL Switch field to choose either DLL enable or DLL disable
- (E-2) Output Driver Impedance Control field for future use.

Once those fields in the Mode Register are set up, the register contents are maintained until the Mode Register is set up again by another MRS command or power supply is lost. The initial value of the Regular or Extended Mode Register after power-up is undefined, therefore the Mode Register Set command must be issued before proper operation.

FUNCTIONAL DESCRIPTION (Continued)

- Regular Mode Register / Extended Mode Register change bits (BA0, BA1)

These bits are used to choose either Regular MRS or Extended MRS

BA1	BA0	A14 - A0
0	0	Regular MRS Cycle
0	1	Extended MRS Cycle
1	X	Reserved

Regular Mode Register Fields

- (R-1) Burst Length field (A2 to A0)

This field specifies the data length for column access using the A2 to A0 pins and sets the Burst Length to be 2 or 4 words.

A2	A1	A0	Burst Length
0	0	0	Reserved
0	0	1	2 words
0	1	0	4 words
0	1	1	Reserved
1	X	X	Reserved

- (R-2) Burst Type field (A3)

The Burst Type can be chosen Interleave mode or Sequential mode. When the A3 bit is “0”, Sequential mode is selected. When the A3 bit is “1”, Interleave mode is selected. Both burst types support burst length of 2 and 4 words.

A3	Burst Type
0	Sequential
1	Interleave

- Addressing sequence of Sequential mode (A3)

A column access is started from the inputted lower address and is performed by incrementing the lower address input to the device. The address is varied by the Burst Length as the following.

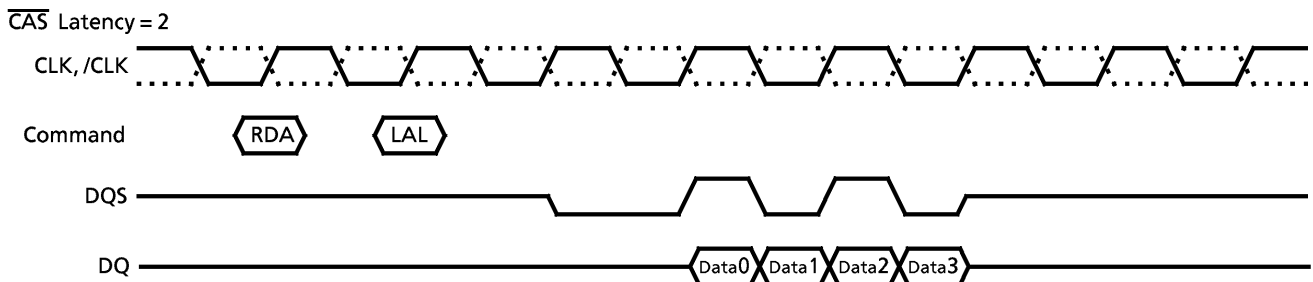

Addressing sequence for Sequential mode

Data	Access Address	Burst Length
Data 0	n	} 2 words (Address bits is LA0) not carried from LA0 to LA1
Data 1	n + 1	
Data 2	n + 2	} 4 words (Address bits is LA1, LA0) not carried from LA1 to LA2
Data 3	n + 3	

FUNCTIONAL DESCRIPTION (Continued)

- Addressing sequence of Interleave mode

A column access is started from the inputted lower address and is performed by interleaving the address bits in the sequence shown as the following.

Addressing sequence for Interleave mode

Data	Access Address	Burst Length
Data 0	...A8 A7 A6 A5 A4 A3 A2 A1 A0	} 2 words
Data 1	...A8 A7 A6 A5 A4 A3 A2 A1 $\overline{A0}$	
Data 2	...A8 A7 A6 A5 A4 A3 A2 $\overline{A1}$ A0	} 4 words
Data 3	...A8 A7 A6 A5 A4 A3 A2 $\overline{A1}$ $\overline{A0}$	

(R-3) $\overline{\text{CAS}}$ Latency field (A6 to A4)

This field specifies the number of clock cycles from the assertion of the LAL command following the RDA command to the first data read. The minimum values of $\overline{\text{CAS}}$ Latency depends on the frequency of CLK. In a write mode, the place of clock which should input write data is $\overline{\text{CAS}}$ Latency cycles - 1.

A6	A5	A4	$\overline{\text{CAS}}$ Latency
0	0	0	Reserved
0	0	1	Reserved
0	1	0	2
0	1	1	3
1	0	0	Reserved
1	0	1	Reserved
1	1	0	Reserved
1	1	1	Reserved

(R-4) Test Mode field (A7)

This bit is used to enter Test Mode for supplier only and must be set to “0” for normal operation.

(R-5) Reserved field in the Regular Mode Register

- Reserved bits (A8 to A14)

These bits are reserved for future operations. They must be set to “0” for normal operation.

FUNCTIONAL DESCRIPTION (Continued)**Extended Mode Register fields****(E-1) DLL Switch field (A0)**

This bit is used to enable DLL. When the A0 bit is set "0", DLL is enabled.

(E-2) Output Driver Impedance Control field (A1)

This bit is used to choose Output Driver Type for the future. Currently, A1 bit must be set to "0".

A1	Output Driver Type
0	Standard Type
1	Reserved

(E-3) Reserved field (A2 to A14)

These bits are reserved for future operations and must be set to "0" for normal operation.

PACKAGE DIMENSIONS (TSOPII 66 - P - 400 - 0.65)

Unit in mm

