

Violet Laser Diode

NLHV500C

■ Features

- Optical Output Power: 5mW
- Single Transverse Mode
- Can Type: $f5.6$

■ Absolute Maximum Ratings

(Tc=25°C)

Item	Symbol	Absolute Maximum Ratings	Unit	
Optical Output Power	CW	Poc	8	mW
	Pulse	Pop	10*	mW
LD Reverse Voltage	Vr (LD)	5	V	
PD Reverse Voltage	Vr (PD)	20	V	
Storage Temperature	Tstg	-35 ~ 100	°C	
Operating Case Temperature	Tc	-10 ~ 60	°C	

*: Pulse Condition Pulse Width<1μs, Duty<50%

■ Initial Electrical/Optical Characteristics

(Tc=25°C, Po=5mW/CW)

Item	Symbol	Min	Typ.	Max	Unit	
Optical Output Power	Po	-	5	-	mW	
Peak Wavelength**	λ_p	400	405	410	nm	
Threshold Current	Ith	20	40	60	mA	
Operating Current	Iop	25	50	70	mA	
Slope Efficiency	η	0.3	0.7	1.0	W/A	
Operating Voltage	Vop	3.5	4.5	5.5	V	
FWHM Beam Divergence	$\theta_{//}$	5	10	16	deg.	
	θ_{\perp}	21	28	34	deg.	
Emission Point Accuracy	Angle	$\Delta\theta_{//}$	-	-	± 2.5	deg.
		$\Delta\theta_{\perp}$	-	-	± 3.0	deg.
	Position	$\Delta X, Y, Z$	-	-	± 80	μm
Monitor Current***	Im	0.2	0.5	0.8	mA	

** FWHM < 1nm

*** Monitor Current may increase or decrease up to 3% in 24 hours.

If your application requires precise output power control, monitor current should not be used as reference for output power. Use additional external PD to monitor output power.

All figures in this specification are measured by Nichia's method and may contain measurement deviations.
NICHIA CORPORATION
<http://www.nichia.co.jp>

HEAD OFFICE: P.O.BOX 6 ANAN, TOKUSHIMA-KEN 774-8601, JAPAN

PHONE: +81-884-22-2311 FAX: +81-884-23-1802

● CONTACT

TOKYO SALES DEPARTMENT OPTOELECTRONICS PRODUCTS DIV.: 13F TAMACHI CENTER BUILDING, 34-7, SHIBA 5-CHOME, MINATO-KU, TOKYO 108-0014, JAPAN

PHONE: +81-3-3456-3108 FAX: +81-3-5440-7330

 E-MAIL: laser@tokyo.nichia.co.jp

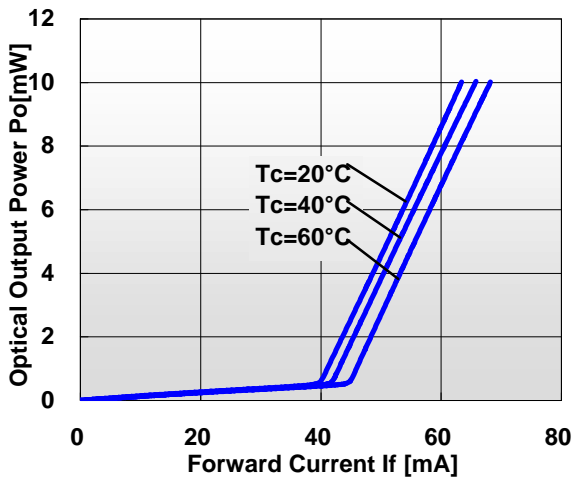
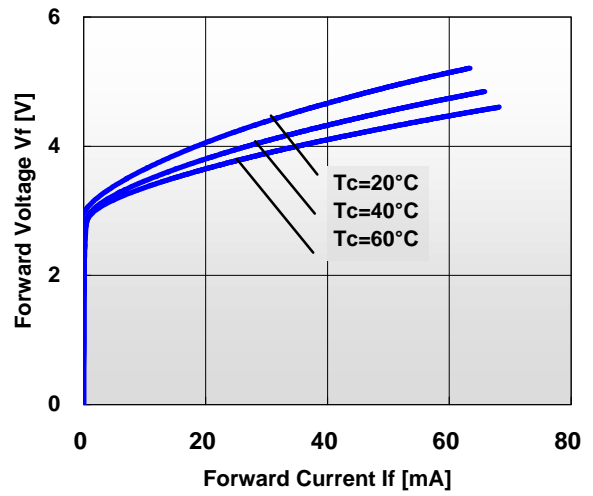
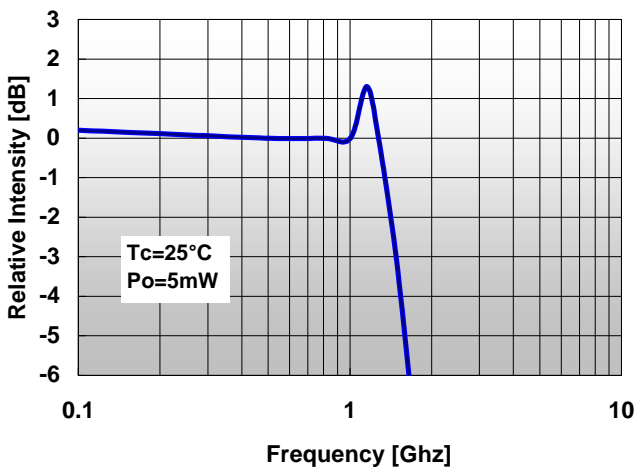
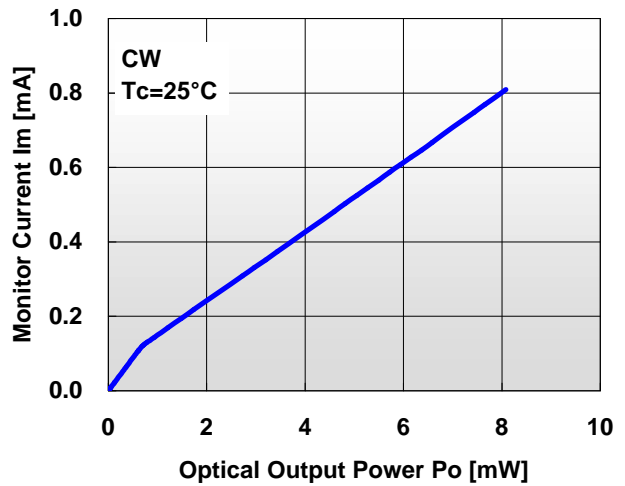
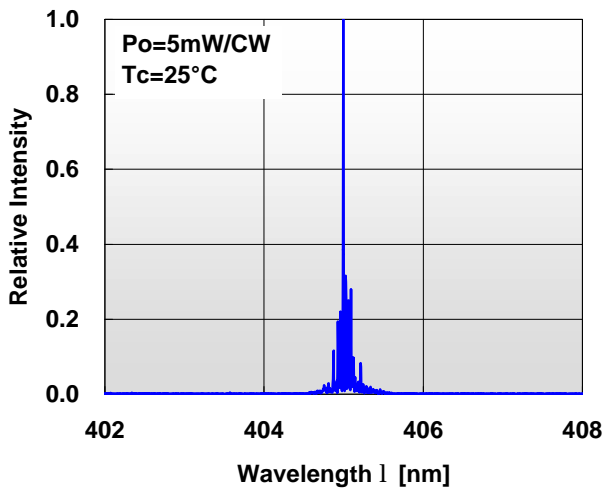
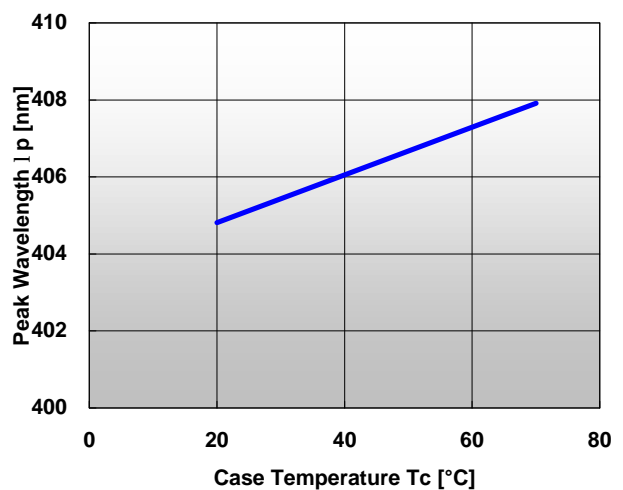
Typical Characteristics
Optical Output Power vs. Forward Current

Forward Voltage vs. Forward Current

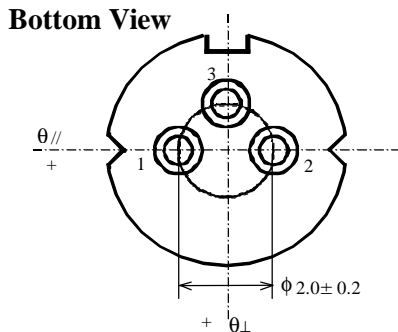
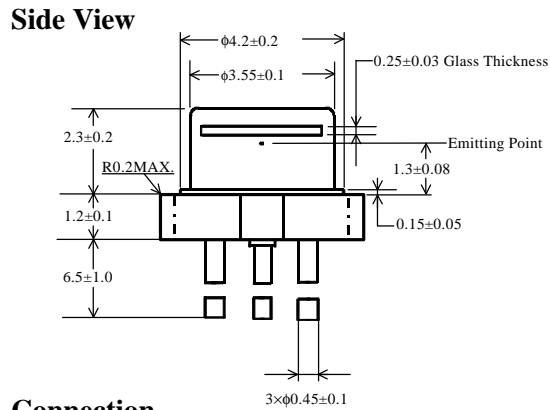
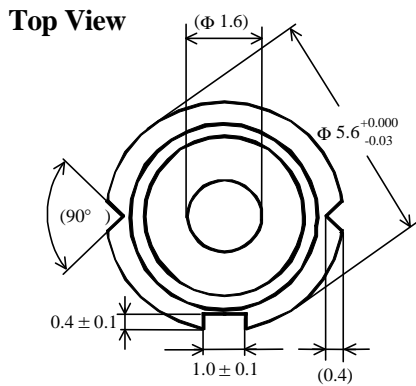
Frequency Response

Monitor Current vs. Optical Output Power

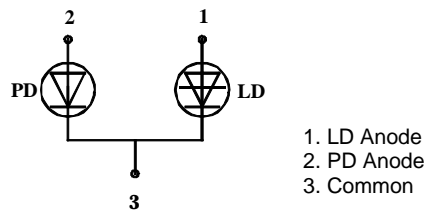
Spectrum

Peak Wavelength vs. Case Temperature

■ Outline Dimension



■ Connection



1. LD Anode
2. PD Anode
3. Common

() are reference figures

■ Safety of Laser light

- **Laser light can damage the human eye and the eyes of animals.** Do not look at any laser light directly or through any optical lens. When handling a laser diode, do not look directly at the light generated by it. Wear appropriate safety glasses to prevent light from entering the eye by reflection off of another surface.
- Nichia LDs are classified in **Class 3B of IEC60825-1 and 21 CFR Part 1040.10 Safety Standards.** It is absolutely necessary to take overall safety measures against User's modules, equipment and systems into which Nichia LDs are incorporated and/or integrated.



This product is classified by 21 CFR Part 1040.10
Manufactured by NICHIA HQP

NICHIA CORPORATION

491-OKA KAMINAKA-CHO ANAN, TOKUSHIMA 774-8601 JAPAN

■ Operating method

- Laser diodes are to change forward voltage and light output power due to the fluctuation in temperature etc. They have some tendency to gradually increase electric current necessary to keep the output power constant during their operation. When precise optical output control is required, it is recommended to use an external photo diode to monitor output power and use APC (Automatic Power Control) function in the operating circuit.

■ Cautions on LD handling

- Static Electricity and surge damage the LDs. It is recommended to use a wrist strap or anti-electrostatic glove when handling the Product.
- Nichia LDs described in this brochure are intended to be used for general electronic equipment(such as office equipment, communications equipment, measurement instruments and household appliances). Consult our sales staff in advance for information on the applications in which exceptional quality and reliability are required, particularly when the failure or malfunction of the products may directly jeopardize life or health(such as for airplanes, aerospace, automobiles, traffic control equipment, life support systems and safety devices.)
- The specifications of the Product may be modified for improvement without prior notice. The formal specifications must be exchanged and signed by both parties before a user starts mass production.
- Strictly prohibited are reverse engineering and disassembly concerning, but not limited to, structure and composition of the Product.
- **Use of controls or adjustments or performance of procedures other than those specified herein may result in hazardous radiation exposure.**