

SFP Optical Transceiver—OC-48 for up to 80-km Reach, OC-12 and Gigabit Ethernet for up to 120-km Reach



Key Features

- Supports line rate from 100 Mbps to 3.1 Gbps
- Compliant with SFP MSA INF-8074i Revision 1.0
- Operating case temperature range -40 to 85°C
- Available in PIN or APD-based receiver
- Maximum power dissipation 1.2 W
- Lead-free and RoHS 6/6-compliant
- Single 3.3 V power supply
- Digital diagnostic monitoring support

Applications

- Metro access and metro core
- Wide area networks
- Optical crossconnects

Compliance

- SFF 8074i MSA
- SFF 8472 Revision 10.4
- GR-253-CORE
- ITU-T G.957
- IEEE 802.3-2005
- Compliance with Telcordia GR-468

The JDSU RoHS-compliant small form factor pluggable (SFP) optical transceiver is an integrated fiber optic transceiver that provides a high-speed serial link at signaling rates from 100 Mbps to 3.1 Gbps. The module complies with the small form factor pluggable (SFP) multisource agreement (MSA).

The SFP optical transceiver complies with Telcordia GR-253-CORE and ITU-T G.957 standards for up to 80-km reach (SONET OC-12 / SDH STM-4; SONET OC-48 / SDH STM-16), and IEEE 802.3-2005 standard for up to 120-km reach (Gigabit Ethernet and 1G Fibre Channel). It is also compatible to Fast Ethernet, SONET OC-3 and OC-12, and SDH STM-1 and STM-4 standards.

The SFP optical transceiver integrates the receive and transmit path on one module. In the transmit side, the serial data stream is passed to a laser driver. The laser drivers biases and modulates an uncooled DML (direct modulated laser), enabling data transmission over single-mode fiber through an industry-standard LC connector. In the receive side, the optical data stream is recovered from a PIN or avalanche photodetector (APD) transimpedance amplifier, and passed to a post amplifier. This module features a hot-pluggable SFI-compliant electrical interface.

Section 1 Functional Description

The JDSU RoHS-compliant Small Form factor Pluggable (SFP) Optical Transceiver is a fully duplex serial electric, serial optical device with both transmit and receive functions contained in a single module that provides a high-speed serial link at signaling rates from 100 Mbps to 3.1 Gbps. It is designed to be compliant with Telcordia GR-253-CORE IR and ITU-T G.957 S-16 standards (PIN receiver based) or Telcordia GR-253-CORE LR and ITU-T G.957 L-4 standards (APD receiver based) (SONET OC-12 / SDH STM-4), Telcordia GR-253-CORE LR and ITU-T G.957 L-16 standards (APD receiver based) (SONET OC-48 / SDH STM-16), IEEE 802.3-2005 for up to 80 km reach (PIN receiver based) or up to 120 km reach (APD receiver based) (Gigabit Ethernet and 1G Fibre Channel) applications. The optical performance for each application is defined in Sections 3.8 to 3.19 below. The JDSU SFP Optical Transceiver is compatible to Fast Ethernet, SONET OC-3 and OC-12, and SDH STM-1 and STM-4 applications. The transceiver is also fully compliant with the Small Form Factor SFP Pluggable Module Multi-Source Agreement INF-8074i Rev. 1.0. A block diagram of the JDSU SFP optical transceiver is shown in Figure 1 below.

The JDSU SFP optical transceiver does not need Rate Select to operate at the designated line rate. It has several low-speed interface connections including a 2-wire serial interface. These connections also include: transceiver presence (Mod_Def(0)), transmitter fault (TX_FAULT), transmitter disable (TX_DIS), and receive loss (RX_LOS).

Transmitter

The transmitter path converts serial NRZ electrical data from line rate of 100 Mbps to 3.1 Gbps to a standard compliant optical signal. The transmitter accepts a 100 Ω differential 300 mV peak-to-peak to 1400 mV peak-to-peak CML electrical signal on TD- and TD+ pins.

Inside the module, the differential signals pass through a laser driver which transforms the small swing digital voltage to an output modulation that drives an uncooled DML laser. The optical signal is engineered to meet the SONET / SDH, Ethernet and Fibre Channel rates specifications. Closed-loop control of the transmitted laser power, modulation swing and center wavelength over temperature and voltage variations is provided. The laser is coupled to single-mode optical fiber through an industry standard LC optical connector.

Receiver

The receiver converts incoming DC balanced serial NRZ optical data from line rate of 100 Mbps to 3.1 Gbps into serial electrical data. Light is coupled to a PIN or APD photodetector from single-mode optical fiber through an industry standard LC optical connector. The electrical current from the PIN or APD photodetector is converted to a voltage in a high-gain transimpedance amplifier.

The amplified signal is passed to a Post Amplifier. Loss of signal, and signal lock detection is included in the receive circuitry that is reflected in the RX_LOS status pin. The recovered data is output on the RD+ and RD- pins as a 100 Ω differential 600 mV to 1600 mV peak-to-peak CML signal. The output signal meets the SFP MSA requirements.

Low-speed Signaling

Low-speed signaling is based on low-voltage TTL (LVTTL) operating at a nominal voltage of 3.3 V.

MOD_DEF(1) / MOD_DEF(2): Two-wire serial interface clock and data line. Hosts should use a pull-up resistor connected to Vcc 3.3 V on the two-wire interface MOD_DEF(1) (clock), MOD_DEF(2) (data), and all low-speed outputs.

TX_FAULT: Output pin. When high, indicates possible transmitter operational fault or a status critical to the host system.

TX_DIS: Input pin. When asserted high, the transmitter output is turned off.

Mod_DEF(0): Output pin. Pulled to ground by the module to indicate that the module is present.

RX_LOS: Output pin. Asserted high when insufficient optical power for reliable signal reception is received.

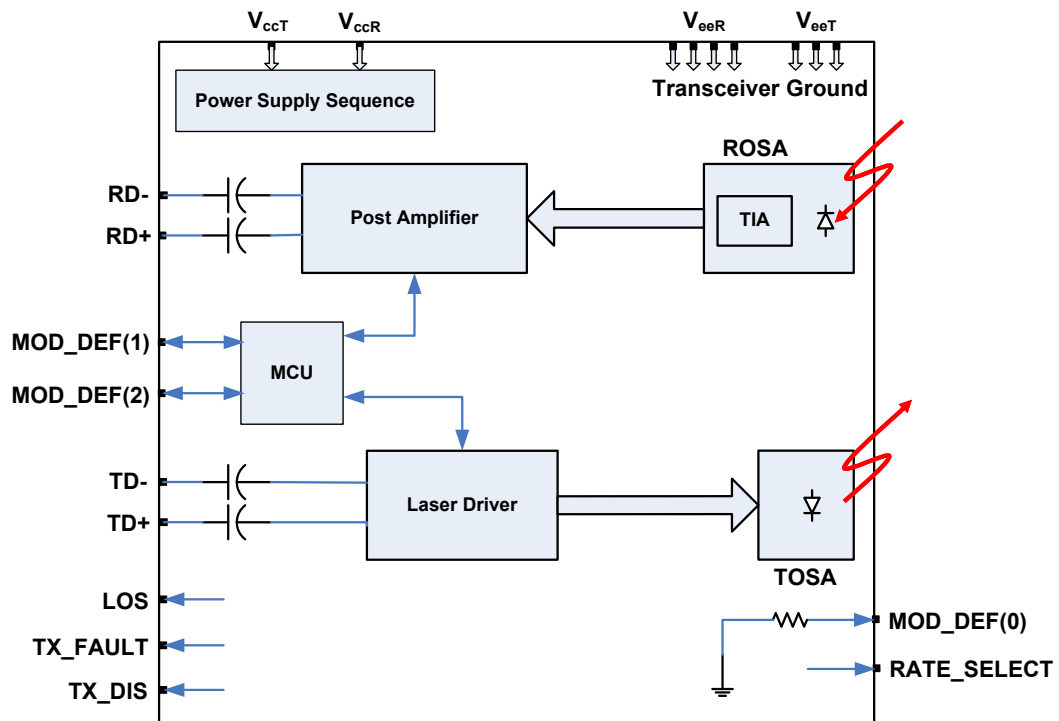
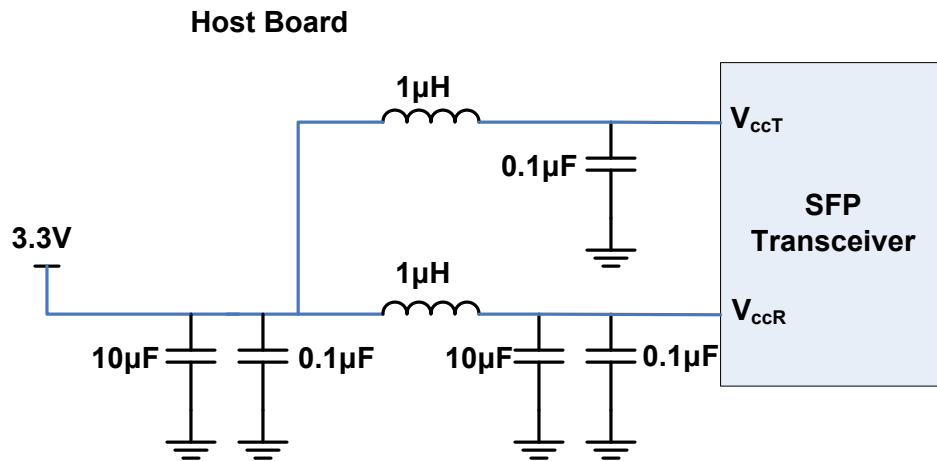

Figure 1 SFP optical transceiver functional block diagram

Section 2 Application Schematics

Power supply filtering is recommended for the JDSU SFP optical transceiver. To limit wide-band noise power, the host system and module shall each meet a maximum of 2 percent peak-to-peak noise when measured with a 1 MHz low-pass filter. In addition, the host system and the module shall each meet a maximum of 3 percent peak-to-peak noise when measured with a filter from 1 – 10 MHz. Recommended power supply network connections to the SFP optical transceiver are shown in Figure 2 below.



Notes:

1. Power supply filtering components should be placed as close to the V_{cc} pins of the host connector as possible for optimal performance.
2. ESR of inductor should be less than 0.5 Ω to ensure proper power supply levels.

Figure 2 Recommended power supply filter network

Section 3 Specifications

Technical specifications related to the JDSU SFP optical transceiver include:

Section 3.1	Pin Function Definitions
Section 3.2	Absolute Maximum Ratings
Section 3.3	Operating Conditions
Section 3.4	Electrical Characteristics
Section 3.5	Jitter Specifications
Section 3.6	Timing Requirement of Control and Status I/O
Section 3.7	SFP Two-wire Interface Protocol and Management Interface
Section 3.8	Optical Characteristics (622 Mbps, 1310 nm, 40 km, APD Receiver, OC-12 LR-1)
Section 3.9	Optical Characteristics (622 Mbps, 1550 nm, 80 km, APD Receiver, OC-12 LR-2)
Section 3.10	Optical Characteristics (622 Mbps, 1550 nm, 120 km, APD Receiver, OC-12 LH)
Section 3.11	Optical Characteristics (1.25 Gbps, 1310 nm, 25 km, PIN Receiver)
Section 3.12	Optical Characteristics (1.25 Gbps, 1310 nm, 40 km, APD Receiver)
Section 3.13	Optical Characteristics (1.25 Gbps, 1550 nm, 40 km, PIN Receiver)
Section 3.14	Optical Characteristics (1.25 Gbps, 1550 nm, 80 km, PIN Receiver)
Section 3.15	Optical Characteristics (1.25 Gbps, 1550 nm, 120 km, APD Receiver)
Section 3.16	Optical Characteristics (2.5 Gbps, 1310 nm, 20 km, PIN Receiver, OC-48 IR-1)
Section 3.17	Optical Characteristics (2.5 Gbps, 1550 nm, 40 km, APD Receiver, OC-48 IR-2)
Section 3.18	Optical Characteristics (2.5 Gbps, 1310 nm, 40 km, APD Receiver, OC-48 LR-1)
Section 3.19	Optical Characteristics (2.5 Gbps, 1550 nm, 80 km, APD Receiver, OC-48 LR-2)
Section 3.20	Regulatory Compliance
Section 3.21	Module Outline
Section 3.22	Connectors

3.1 Pin Function Definitions

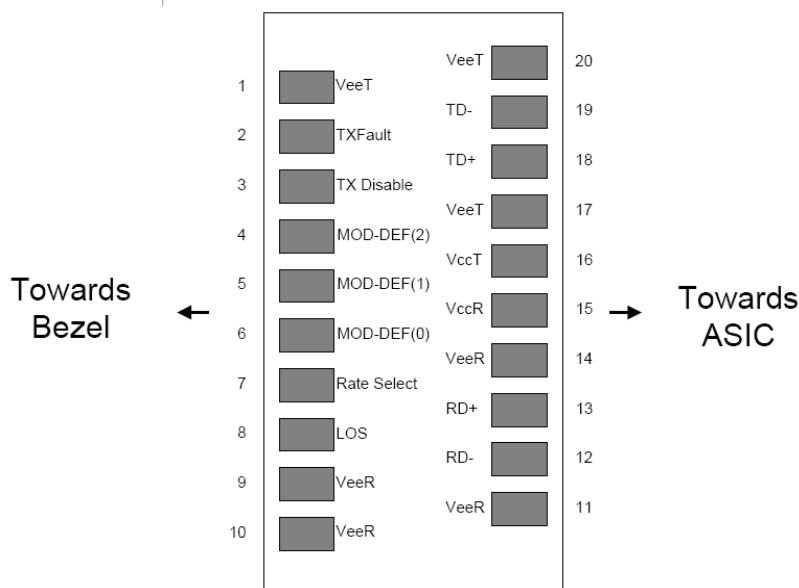

Figure 3 SFP optical transceiver pin-out on host board

6

Table 1 SFP Optical Transceiver Pin Descriptions

Pin Number	Type	Name	Description
1	VeeT	GND ¹	Transmit ground
2	TX_FAULT ²	LVTTL-O	Transmitter fault indicator
3	TX_DIS	LVTTL-I	Transmitter disable; transmitter laser source turned off
4	MOD_DEF(2)	LVTTL-I	2-Wire serial interface data
5	MOD_DEF(1)	LVTTL-I	2-Wire serial interface clock
6	MOD_DEF(0)		Transceiver presence, pull down to GND via a 499 Ω resistor.
7	Rate_select	CMOS	No connect
8	RX_LOS ²	LVTTL-O	Receive loss of signal
9	VeeT	GND ¹	Transmit ground
10	VeeR	GND ¹	Receive ground
11	VeeR	GND ¹	Receive ground
12	RD-	CML	Receiver inverted data output
13	RD+	CML	Receiver non-inverted data output
14	VeeR	GND ¹	Receive ground
15	VccR		Receive power; 3.3 V
16	VccT		Transmit power; 3.3 V
17	VeeT	GND ¹	Transmit ground
18	TD+	CML	Transmitter non-inverted data input
19	TD-	CML	Transmitter inverted data input
20	VeeT	GND ¹	Transmit ground

1. Module ground pins (GND) are isolated from the module case and chassis ground within the module
2. Shall be pulled up with 4.7 – 10 k Ω to a voltage between 3.15 and 3.45 V on the host board

3.2 Absolute Maximum Ratings

Parameter	Symbol	Ratings	Unit
Storage temperature	T _{ST}	-40 to +85	°C
Operating case temperature			
- Industrial temperature range	T _{OP}	-40 to +85	°C
- Commercial temperature range	T _{OP}	-5 to +70	°C
Relative humidity	RH	5 to 95 (noncondensing)	%
Static electrical discharge (human body model)	ESD	500	V
Power supply voltages	V _{CC3}	-0.3 to 4.0	V
Receive input optical power (damage threshold)			
- PIN	P _{dth}	5	dBm
-APD	P _{dth}	3	dBm

Note:
Absolute maximum ratings represent the damage threshold of the device. Damage may occur if the device is operated above the limits stated here except for brief excursions. Performance is not guaranteed and reliability is not implied for operation at any condition outside the recommended operating limits.

7

3.3 Operating Conditions

Part Number	Gigabit Ethernet	SONET/SDH	Center Wavelength (1310 nm)	Center Wavelength (1550 nm)	Commercial Temperature (-5 to 70°C)	Industrial Temperature (-40 to 85°C)
SFP-PL1LKTD3DCA		OC-12/40 km	X			X
SFP-PL2LKTD5DCA		OC-12/80 km		X		X
SFP-PE2LKTD5DCA		OC-12/120 km		X		X
SFP-GI1LKTD3DCA	40 km		X			X
SFP-GS2LKTD5DCA	40 km			X		X
SFP-GI2LKTD5DCA	80 km			X		X
SFP-GL1LKTD3DCA	60 km		X			X
SFP-GL2LKTD5DCA	120 km			X		X
SFP-MI1LKTD3DCA		OC-48/20 km	X			X
SFP-MI2LKTD5DCA		OC-48/40 km		X		X
SFP-ML1LCTD3DCA		OC-48/40 km	X		X	
SFP-ML1LKTD3DCA		OC-48/40 km	X			X
SFP-ML2LCTD5DCA		OC-48/80 km		X	X	
SFP-ML2LKTD5DCA		OC-48/80 km		X		X

3.4 Electrical Characteristics

Parameter	Symbol	Minimum	Typical	Maximum	Unit	Notes
Supply currents and voltages						
Supply voltage	V_{CC}	3.13	3.3	3.47	V	With respect to GND
Supply current	I_{CC}			300	mA	
Power dissipation	P_{wr}			1.2	W	
Data rate		100		3125	Mbps	
Low-speed control and sense signals (detailed specification in SFP MSA INF8074i Rev. 1.0)						
Outputs (TX_FAULT, RX_LOS)	V_{OL}	0		0.4	V	Rpullup pulled to host V_{CC} , measured at host side of connector. $I_{OL(max)}=3$ mA
	V_{OH}	host $V_{CC}-0.5$		host $V_{CC}+0.3$	V	Rpullup pulled to host V_{CC} , measured at host side of connector
Inputs (TX_DIS)	V_{IL}	-0.3		0.8	V	Pulled up in module to V_{CC}
	V_{IH}	2		$V_{CC}+0.3$	V	Pulled up in module to V_{CC}
MOD_DEF(1) / MOD_DEF(2)	V_{IL}	-0.3		$V_{CC}+0.3$	V	Rpullup pulled to host V_{CC} , measured at SFP side of connector
	V_{IH}	$V_{CC}+0.7$		$V_{CC}+0.5$	V	Rpullup pulled to host V_{CC} , measured at SFP side of connector
Low-speed control and sense signals (detailed specification in SFP MSA INF8074i Rev. 1.0)						
High speed signals (detailed specification in SFP MSA INF8074i Rev. 1.0)						
Input data signal levels ¹	DV_{IN}	300		1400	mV	Differential voltage swing
Output data signal levels ¹	DV_{OUT}	600		1600	mV	Differential voltage swing
Data output rise/fall time	tr / tf			175	ps	20 – 80%, differential

1. Internally AC coupled. Terminated into 100 Ω differential. These levels are guaranteed down to 2 dB lower than the typical receiver sensitivity for each data rate and reach.

8

3.5 Jitter Specifications

Parameter	Max	Unit	Notes
Jitter generation (peak to peak)	70	mUI(p-p)	PRBS 2 ²³ -1 data pattern, at OC-48 data rate
Jitter generation (rms)	7	mUI(rms)	
Jitter transfer / Jitter tolerance	Compliant with Telcordia GR253 when operated with a SONET-compliant CDR		

3.6 Timing Requirement of Control and Status I/O

Parameter	Symbol	Min	Max	Unit	Notes
TX_DIS assert time	t_off		10	µsec	Rising edge of TX_DIS to fall of output signal below 10% of nominal
TX_DIS negate time	t_on		1	msec	Falling edge of TX_DIS to rise of output signal above 90% of nominal
Time to initialize	t_init		60	sec	Upon power up or negation of TX_FAULT due to TX_DISABLE
Time to initialize after reset of TX_FAULT/INT in normal operation	t_init reset		300	msec	From negation of TX_FAULT/INT using TX_DISABLE Optical power going to 90% of final value
TX_FAULT assert time	t_fault		100	µsec	Time from a fault condition to TX_FAULT assertion
TX_DISABLE for reset	t_reset	10		µsec	Time TX_DISABLE must be held HIGH to reset TX_FAULT
RX_LOS assert time ¹	t_loss_on		100	µsec	Time from loss of signal to assertion of RX_LOS
RX_LOS deassert time	t_loss_off		100	µsec	Time from nonloss condition to RX_LOS deassertion
2-wire serial clock rate	f_serial_clock		100	kHz	

1. The RX_LOS assert time can be 200 µsec max when the optical input power is greater than -10 dBm immediately prior to the RX_LOS condition.

3.7 SFP Two-wire Interface Protocol and Management Interface

The DWDM SFP optical transceiver incorporates a SFP compliant two-wire management interface, which is used for serial ID, digital diagnostics, and certain control functions. It is modeled on the DWDM SFP MSA Rev. 1.0 specification modified to accommodate a single two-wire interface address. Details of the protocol and interface are explicitly described in the MSA. Please refer to the MSA for design reference.

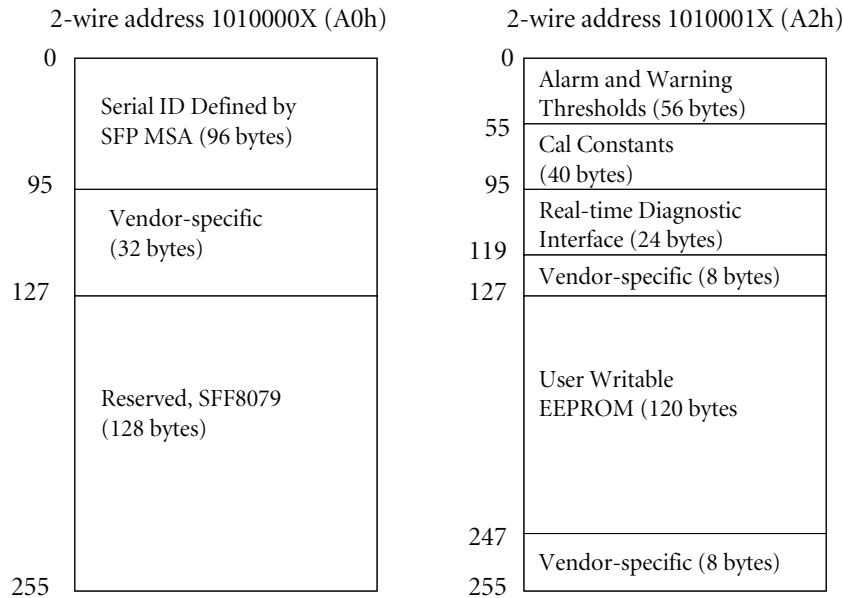

Figure 4 SFP two-wire serial digital diagnostic memory map

3.8 Optical Characteristics (622 Mbps, 1310 nm, 40 km, APD Receiver, OC-12 LR-1)

Parameter	Symbol	Minimum	Typical	Maximum	Unit
Average optical power (EOL)	P_{avg}	-3.0		2.0	dBm
Extinction ratio (EOL) ¹	ER	10			dB
Optical power with transmitter disabled				-40	dBm
Transmit center wavelength	λ_p	1260	1310	1360	nm
-20 dB spectral width	$\Delta\lambda$		0.3	1.0	nm
Sidemode suppression ratio	SMSR	30			dB
Optical rise / fall time (20 – 80 %)				250	ps
Optical eye mask margin ²	MM	10			%
Optical path penalty	P_{PATH}			1	dB
Optical return loss		24			dB
Receiver center wavelength	λ	1260		1620	nm
Receiver sensitivity (EOL) ³	R_{sen}			-28	dBm
Receive overload ³	P_{max}	-8.0			dBm
Receiver reflectance	R_{rx}			-27	dB
RX_LOS assert	P_{los_on}	-34		-40	dBm
RX_LOS deassert	P_{los_off}			-33.5	dBm
RX_LOS hysteresis		0.5		4	dB

1. Tested with PRBS 2²³-1 pattern.

2. Measured with PRBS 2²³ - 1 pattern; with 1000 waveforms.

3. Measured with worst ER; BER < 10⁻¹²; PRBS 2²³-1 pattern.

10

3.9 Optical Characteristics (622 Mbps, 1550 nm, 80 km, APD Receiver, OC-12 LR-2)

Parameter	Symbol	Minimum	Typical	Maximum	Unit
Average optical power (EOL)	P_{avg}	-3.0		2.0	dBm
Chromatic dispersion tolerance	DT_{CD}			2400	ps/nm
Extinction ratio (EOL) ¹	ER	10			dB
Optical power with transmitter disabled				-40	dBm
Transmit center wavelength	λ_p	1500		1580	nm
-20 dB spectral width	$\Delta\lambda$		0.3	1.0	nm
Sidemode suppression ratio	SMSR	30			dB
Optical rise / fall time (20 – 80 %)				250	ps
Optical eye mask margin ²	MM	10			%
Optical path penalty	P_{PATH}			2	dB
Optical return loss		24			dB
Receiver center wavelength	λ	1260		1620	nm
Receiver sensitivity (EOL) ³	R_{sen}			-28	dBm
Receive overload ³	P_{max}	-8.0			dBm
Receiver reflectance	R_{rx}			-27	dB
RX_LOS assert	P_{los_on}	-34		-40	dBm
RX_LOS deassert	P_{los_off}			-33.5	dBm
RX_LOS hysteresis		0.5		4	dB

1. Tested with PRBS 2²³-1 pattern.

2. Measured with PRBS 2²³ - 1 pattern; with 1000 waveforms.

3. Measured with worst ER; BER < 10⁻¹²; PRBS 2²³-1 pattern.

3.10 Optical Characteristics (622 Mbps, 1550 nm, 120 km, APD Receiver, OC12 LH)

Parameter	Symbol	Minimum	Typical	Maximum	Unit
Average optical power (EOL)	P_{avg}	0.0		4.0	dBm
Chromatic dispersion tolerance	DT_{CD}			2400	ps/nm
Extinction ratio (EOL) ¹	ER	10			dB
Optical power with transmitter disabled				-40	dBm
Transmit center wavelength	λ_p	1500		1580	nm
-20 dB spectral width	$\Delta\lambda$		0.3	1.0	nm
Sidemode suppression ratio	SMSR	30			dB
Optical rise / fall time (20 – 80 %)				250	ps
Optical eye mask margin ²	MM	10			%
Optical path penalty	P_{PATH}			2	dB
Optical return loss		24			dB
Receiver center wavelength	λ	1260		1620	nm
Receiver sensitivity (EOL) ³	R_{sen}			-34	dBm
Receive overload ³	P_{max}	-8.0			dBm
Receiver reflectance	R_{rx}			-27	dB
RX_LOS assert	P_{los_on}	-37		-42	dBm
RX_LOS deassert	P_{los_off}			-36.5	dBm
RX_LOS hysteresis		0.5		4	dB

1. Tested with PRBS 2²³-1 pattern.

2. Measured with PRBS 2²³ - 1 pattern; with 1000 waveforms.

3. Measured with worst ER; BER < 10⁻¹²; PRBS 2²³-1 pattern.

11

3.11 Optical Characteristics (1.25 Gbps, 1310 nm, 25 km, PIN Receiver)

Parameter	Symbol	Minimum	Typical	Maximum	Unit
Average optical power (EOL)	P_{avg}	-5.0		0.0	dBm
Extinction ratio (EOL) ¹	ER	9			dB
Optical power with transmitter disabled				-40	dBm
Transmit center wavelength	λ_p	1280	1310	1360	nm
-20 dB spectral width	$\Delta\lambda$		0.3	1.0	nm
Sidemode suppression ratio	SMSR	30			dB
Optical rise / fall time (20 – 80 %)				200	ps
Optical eye mask margin ²	MM	10			%
Optical path penalty	P_{PATH}			1	dB
Optical return loss		24			dB
Receiver center wavelength	λ	1260		1620	nm
Receiver sensitivity (EOL) ³	R_{sen}			-23	dBm
Receive overload ³	P_{max}	1.0			dBm
Receiver reflectance	R_{rx}			-27	dB
RX_LOS assert	P_{los_on}	-25		-31	dBm
RX_LOS deassert	P_{los_off}			-24.5	dBm
RX_LOS hysteresis		0.5		4	dB

1. Tested with PRBS 2⁷-1 pattern.

2. Measured with PRBS 2⁷ - 1 pattern; with 1000 waveforms.

3. Measured with worst ER; BER < 10⁻¹²; PRBS 2⁷-1 pattern.

3.12 Optical Characteristics (1.25 Gbps, 1550 nm, 40 km, PIN Receiver)

Parameter	Symbol	Minimum	Typical	Maximum	Unit
Average optical power (EOL)	P_{avg}	-5.0	-2.0	0.0	dBm
Chromatic dispersion tolerance	DT_{CD}			800	ps/nm
Extinction ratio (EOL) ¹	ER	9.0			dB
Optical power with transmitter disabled				-40	dBm
Transmit center wavelength	λ_p	1480		1580	nm
-20 dB spectral width	$\Delta\lambda$		0.3	1.0	nm
Sidemode suppression ratio	SMSR	30			dB
Optical rise / fall time (20 – 80 %)				200	ps
Optical eye mask margin ²	MM	10			%
Optical path penalty	P_{PATH}			2	dB
Optical return loss		24			dB
Receiver center wavelength	λ	1260		1620	nm
Receiver sensitivity (EOL) ³	R_{sen}			-24	dBm
Receive overload ³	P_{max}	>1.0			dBm
Receiver reflectance	R_{rx}			-27	dB
RX_LOS assert	P_{los_on}	-25		-31	dBm
RX_LOS deassert	P_{los_off}			-24.5	dBm
RX_LOS hysteresis		0.5		4	dB

1. Tested with PRBS 2⁷-1 pattern.

2. Measured with PRBS 2⁷ - 1 pattern; with 1000 waveforms.

3. Measured with worst ER; BER < 10⁻¹²; PRBS 2⁷-1 pattern.

12

3.13 Optical Characteristics (1.25 Gbps, 1550 nm, 80 km, PIN Receiver)

Parameter	Symbol	Minimum	Typical	Maximum	Unit
Average optical power (EOL)	P_{avg}	0.0	2.0	5.0	dBm
Chromatic dispersion tolerance	DT_{CD}			1600	ps/nm
Extinction ratio (EOL) ¹	ER	9.0			dB
Optical power with transmitter disabled				-40	dBm
Transmit center wavelength	λ_p	1480		1580	nm
-20 dB spectral width	$\Delta\lambda$		0.3	1.0	nm
Sidemode suppression ratio	SMSR	30			dB
Optical rise / fall time (20 – 80 %)				200	ps
Optical eye mask margin ²	MM	10			%
Optical path penalty	P_{PATH}			2	dB
Optical return loss		24			dB
Receiver center wavelength	λ	1260		1620	nm
Receiver sensitivity (EOL) ³	R_{sen}			-24	dBm
Receive overload ³	P_{max}	>1.0			dBm
Receiver reflectance	R_{rx}			-27	dB
RX_LOS assert	P_{los_on}	-25		-31	dBm
RX_LOS deassert	P_{los_off}			-24.5	dBm
RX_LOS hysteresis		0.5		4	dB

1. Tested with PRBS 2⁷-1 pattern.

2. Measured with PRBS 2⁷ - 1 pattern; with 1000 waveforms.

3. Measured with worst ER; BER < 10⁻¹²; PRBS 2⁷-1 pattern.

3.14 Optical Characteristics (1.25 Gbps, 1310 nm, 40 km, APD Receiver)

Parameter	Symbol	Minimum	Typical	Maximum	Unit
Average optical power (EOL)	P_{avg}	-2.0		2.0	dBm
Extinction ratio (EOL) ¹	ER	9.0			dB
Optical power with transmitter disabled				-40	dBm
Transmit center wavelength	λ_p	1260	1310	1360	nm
-20 dB spectral width	$\Delta\lambda$		0.3	1.0	nm
Sidemode suppression ratio	SMSR	30			dB
Optical rise / fall time (20 – 80 %)				200	ps
Optical eye mask margin ²	MM	10			%
Optical path penalty	P_{PATH}			1	dB
Optical return loss		24			dB
Receiver center wavelength	λ	1260		1620	nm
Receiver sensitivity (EOL) ³	R_{sen}			-32	dBm
Receive overload ³	P_{max}	-8.0			dBm
Receiver reflectance	R_{rx}			-27	dB
RX_LOS assert	P_{los_on}	-33		-40	dBm
RX_LOS deassert	P_{los_off}			-32.5	dBm
RX_LOS hysteresis		0.5		4	dB

1. Tested with PRBS 2⁷-1 pattern.

2. Measured with PRBS 2⁷ - 1 pattern; with 1000 waveforms.

3. Measured with worst ER; BER < 10⁻¹²; PRBS 2⁷-1 pattern.

13

3.15 Optical Characteristics (1.25 Gbps, 1550 nm, 120 km, APD Receiver)

Parameter	Symbol	Minimum	Typical	Maximum	Unit
Average optical power (EOL)	P_{avg}	0.0		4.0	dBm
Chromatic dispersion tolerance	DT_{CD}			2400	ps/nm
Extinction ratio (EOL) ¹	ER	9.0			dB
Optical power with transmitter disabled				-40	dBm
Transmit center wavelength	λ_p	1500		1580	nm
-20 dB spectral width	$\Delta\lambda$		0.3	1.0	nm
Sidemode suppression ratio	SMSR	30			dB
Optical rise / fall time (20 – 80 %)				200	ps
Optical eye mask margin ²	MM	10			%
Optical path penalty	P_{PATH}			2	dB
Optical return loss		24			dB
Receiver center wavelength	λ	1260		1620	nm
Receiver sensitivity (EOL) ³	R_{sen}			-32	dBm
Receive overload ³	P_{max}	-8.0			dBm
Receiver reflectance	R_{rx}			-27	dB
RX_LOS assert	P_{los_on}	-34		-40	dBm
RX_LOS deassert	P_{los_off}			-32.5	dBm
RX_LOS hysteresis		0.5		4	dB

1. Tested with PRBS 2⁷-1 pattern.

2. Measured with PRBS 2⁷ - 1 pattern; with 1000 waveforms.

3. Measured with worst ER; BER < 10⁻¹²; PRBS 2⁷-1 pattern.

3.16 Optical Characteristics (2.5 Gbps, 1310 nm, 20 km, PIN Receiver, OC-48 IR-1)

Parameter	Symbol	Minimum	Typical	Maximum	Unit
Average optical power (EOL)	P_{avg}	-5.0		0.0	dBm
Extinction ratio (EOL) ¹	ER	8.2			dB
Optical power with transmitter disabled				-40	dBm
Transmit center wavelength	λ_p	1260	1310	1360	nm
-20 dB spectral width	$\Delta\lambda$		0.3	1.0	nm
Sidemode suppression ratio	SMSR	30			dB
Optical rise / fall time (20 – 80 %)				200	ps
Optical eye mask margin ²	MM	10			%
Optical path penalty	P_{PATH}			1	dB
Optical return loss		24			dB
Receiver center wavelength	λ	1260		1620	nm
Receiver sensitivity (EOL) ³	R_{sen}			-19	dBm
Receive overload ³	P_{max}	0.0			dBm
Receiver reflectance	R_{rx}			-27	dB
RX_LOS assert	P_{los_on}	-25		-31	dBm
RX_LOS deassert	P_{los_off}			-24.5	dBm
RX_LOS hysteresis		0.5		4	dB

1. Tested with PRBS 2²³-1 pattern.

2. Measured with PRBS 2²³ - 1 pattern; with 1000 waveforms.

3. Measured with worst ER; BER < 10⁻¹²; PRBS 2²³-1 pattern.

14

3.17 Optical Characteristics (2.5 Gbps, 1550 nm, 40 km, PIN Receiver, OC-48 IR-2)

Parameter	Symbol	Minimum	Typical	Maximum	Unit
Average optical power (EOL)	P_{avg}	-5.0		0.0	dBm
Chromatic dispersion tolerance	DT_{CD}			800	ps/nm
Extinction ratio (EOL) ¹	ER	8.2			dB
Optical power with transmitter disabled				-40	dBm
Transmit center wavelength	λ_p	1430	1550	1580	nm
-20 dB spectral width	$\Delta\lambda$		0.3	1.0	nm
Sidemode suppression ratio	SMSR	30			dB
Optical rise / fall time (20 – 80 %)				200	ps
Optical eye mask margin ²	MM	10			%
Optical path penalty	P_{PATH}			2	dB
Optical return loss		24			dB
Receiver center wavelength	λ	1260		1620	nm
Receiver sensitivity (EOL) ³	R_{sen}			-19	dBm
Receive overload ³	P_{max}	0.0			dBm
Receiver reflectance	R_{rx}			-27	dB
RX_LOS assert	P_{los_on}	-25		-31	dBm
RX_LOS deassert	P_{los_off}			-24.5	dBm
RX_LOS hysteresis		0.5		4	dB

1. Tested with PRBS 2²³-1 pattern.

2. Measured with PRBS 2²³ - 1 pattern; with 1000 waveforms.

3. Measured with worst ER; BER < 10⁻¹²; PRBS 2²³-1 pattern.

3.18 Optical Characteristics (2.5 Gbps, 1310 nm, 40 km, APD Receiver, OC-48 LR-1)

Parameter	Symbol	Minimum	Typical	Maximum	Unit
Average optical power (EOL)	P_{avg}	-2.0		2.0	dBm
Extinction ratio (EOL) ¹	ER	8.2			dB
Optical power with transmitter disabled				-40	dBm
Transmit center wavelength	λ_p	1260	1310	1360	nm
-20 dB spectral width	$\Delta\lambda$		0.3	1.0	nm
Sidemode suppression ratio	SMSR	30			dB
Optical rise / fall time (20 – 80 %)				200	ps
Optical eye mask margin ²	MM	10			%
Optical path penalty	P_{PATH}			1	dB
Optical return loss		24			dB
Receiver center wavelength	λ	1260		1620	nm
Receiver sensitivity (EOL) ³	R_{sen}			-29	dBm
Receive overload ³	P_{max}	-8.0			dBm
Receiver reflectance	R_{rx}			-27	dB
RX_LOS assert	P_{los_on}	-32		-40	dBm
RX_LOS deassert	P_{los_off}			-31	dBm
RX_LOS hysteresis		0.5		4	dB

1. Tested with PRBS 2²³-1 pattern.

2. Measured with PRBS 2²³ - 1 pattern; with 1000 waveforms.

3. Measured with worst ER; BER < 10⁻¹²; PRBS 2²³-1 pattern.

3.19 Optical Characteristics (2.5 Gbps, 1550 nm, 80 km, APD Receiver, OC-48 LR-2)

Parameter	Symbol	Minimum	Typical	Maximum	Unit
Average optical power (EOL)	P_{avg}	-2.0		3.0	dBm
Chromatic dispersion tolerance	DT_{CD}			1600	ps/nm
Extinction ratio (EOL) ¹	ER	8.2			dB
Optical Power Overshoot				2.0	dB
Optical power with transmitter disabled				-40	dBm
Transmit center wavelength	λ_p	1430	1550	1580	nm
-20 dB spectral width	$\Delta\lambda$		0.3	1.0	nm
Sidemode suppression ratio	SMSR	30			dB
Optical rise / fall time (20 – 80 %)				200	ps
Optical eye mask margin ²	MM	10			%
Optical path penalty ³	P_{PATH}			3	dB
Optical return loss		24			dB
Receiver center wavelength	λ	1260		1620	nm
Receiver sensitivity (EOL) ⁴	R_{sen}			-29	dBm
Receive overload ⁴	P_{max}	-8.0			dBm
Receiver reflectance	R_{rx}			-27	dB
RX_LOS assert	P_{los_on}	-33		-40	dBm
RX_LOS deassert	P_{los_off}			-31	dBm
RX_LOS hysteresis		0.5		4	dB

1. Tested with PRBS 2²³-1 pattern.

2. Measured with PRBS 2²³ - 1 pattern; with 1000 waveforms.

3. Guaranteed at 2.488 Gbps; at BER < 10⁻¹⁰; PRBS 2²³-1 pattern.

4. Measured with worst ER; BER < 10⁻¹²; PRBS 2²³-1 pattern.

3.20 Regulatory Compliance

The JDSU SFP optical transceiver is lead-free and RoHS 6/6-compliant per Directive 2002/95/EC of the European Parliament and of the Council of 27 January 2003 on the restriction of the use of certain hazardous substances in electrical and electronic equipment.

The SFP optical transceiver complies with international electromagnetic compatibility (EMC) and international safety requirements and standards. EMC performance is dependent on the overall system design. Information included herein is intended as a figure of merit for designers to use as a basis for design decisions.

Table 2 Regulatory Compliance

Feature	Test Method	Performance
Component safety	UL 60950 UL94-V0 EN 60950	TUV Certificate TUV Certificate TUV Report/Certificate (CB Scheme)
RoHS-compliance	Directive 2002/95/EC	Compliant per the Directive 2002/95/EC of the European Parliament and of the Council of 27 January 2003 on the restriction of the use of certain hazardous substances in electrical and electronic equipment
Laser eye safety	EN 60825 U.S. 21CFR 1040.10	TUV Certificate CDRH compliant and Class 1 laser eye safe
Electromagnetic Compatibility		
Electromagnetic emissions	EMC Directive 89/336/EEC FCC CFR47 Part 15 IEC/CISPR 22 AS/NZS CISPR22 EN 55022 ICES-003, Issue 4 VCCI-03	Noise frequency range: 30 MHz to 40 GHz. Good system EMI design practice required to achieve Class B margins.
Electromagnetic immunity	EMC Directive 89/336/EEC IEC /CISPR/24 EN 55024	
ESD immunity	EN 61000-4-2	Exceeds requirements. Withstands discharges of; 8 kV contact, 15 kV air
Radiated immunity	EN 61000-4-3	Exceeds requirements. Field strength of 10 V/m RMS, from 10 MHz to 1 GHz. No effect on transmitter/receiver performance is detectable between these limits.

17

3.21 Module Outline

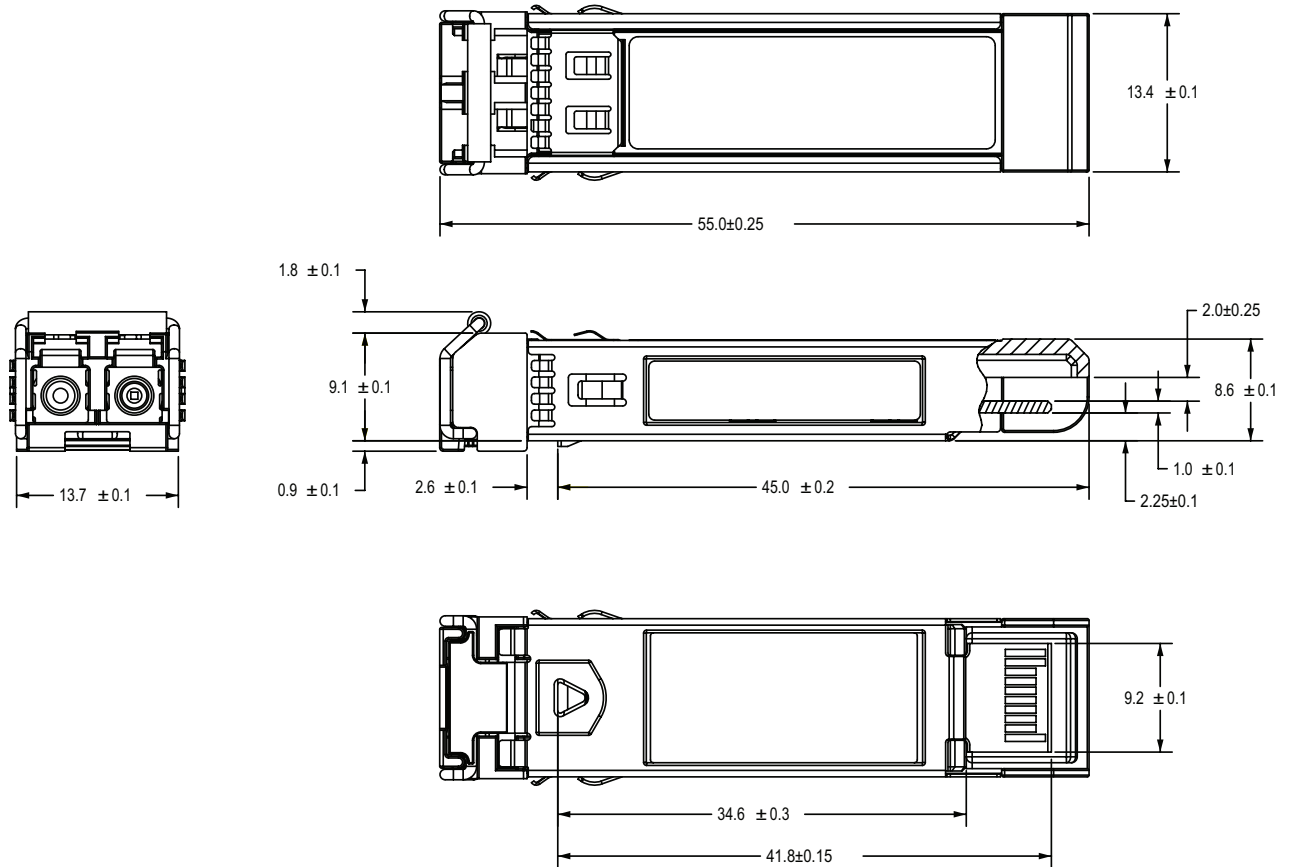

Figure 5 Module Outline

3.22 Connectors

Fiber

The SFP module has a duplex LC receptacle connector.

Electrical

The electrical connector is the 20-way, two-row PCB edge connector.

Section 4 Related Information

Other information related to the DWDM SFP optical transceiver includes:

- Section 4.1 Packing and Handling Instructions
- Section 4.2 ESD Discharge (ESD)
- Section 4.3 Eye Safety

4.1 Package and Handling Instructions

Connector covers

The JDSU SFP optical transceiver is supplied with an LC duplex receptacle. The connector plug supplied protects the connector during standard manufacturing processes and handling by preventing contamination from dust, aqueous solutions, body oils, or airborne particles.

Note: It is recommended that the connector plug remain on whenever the transceiver optical fiber connector is not inserted.

Recommended cleaning and degreasing chemicals

JDSU recommends the use of methyl, isopropyl and isobutyl alcohols for cleaning.

Do not use halogenated hydrocarbons (trichloroethane, ketones such as acetone, chloroform, ethyl acetate, MEK, methylene chloride, methylene dichloride, phenol, N-methylpyrrolidone).

This product is not designed for aqueous wash.

Housing

The JDSU SFP optical transceiver housing is made from die-cast zinc and stainless steel sheet metal.

4.2 ESD Discharge (ESD)

Handling

Normal ESD precautions are required during the handling of this module. This transceiver is shipped in ESD protective packaging. It should be removed from the packaging and otherwise handled in an ESD protected environment utilizing standard grounded benches, floor mats, and wrist straps.

Test and operation

In most applications, the optical connector will protrude through the system chassis and be subjected to the same ESD environment as the system. Once properly installed in the system, this transceiver should meet and exceed common ESD testing practices and fulfill system ESD requirements.

Typical of optical transceivers, this module's receiver contains a highly sensitive optical detector and amplifier which may become temporarily saturated during an ESD strike. This could result in a short burst of bit errors. Such an event might require that the application reacquire synchronization at the higher layers (serializer/deserializer chip).

4.3 Eye Safety

The JDSU SFP optical transceiver is an international Class 1 laser product per IEC 60825-1 second edition 2007. The product also complies with U.S.A. regulations for Class 1 products contained in 21 CFR 1040.10 and 1040.11. Laser emissions from Class 1 laser products are not considered hazardous when operated within the limits of this specification.

Operating this product in a manner inconsistent with intended usage and specification may result in hazardous radiation exposure.



Caution

Tampering with this laser based product or operating this product outside the limits of this specification may be considered an act of “manufacturing,” and will require, under law, recertification of the modified product with the U.S. Food and Drug Administration (21 CFR 1040).

Ordering Information

For more information on this or other products and their availability, please contact your local JDSU account manager or JDSU directly at 1-800-498-JDSU (5378) in North America and +800-5378-JDSU worldwide, or via e-mail at customer.service@jdsu.com.

Sample: SFP-PL1LKTD3DCA

Product Code	Description
SFP-PL1LKTD3DCA	SFP transceiver OC12 LR-1 1310 nm 40 km industrial temperature
SFP-PL2LKTD5DCA	SFP transceiver OC12 LR-2 1550 nm 80 km industrial temperature
SFP-PE2LKTD5DCA	SFP transceiver OC12 LH 1550 nm 120 km industrial temperature
SFP-G11LKTD3DCA	SFP transceiver GbE 1310 nm 25 km industrial temperature
SFP-GL1LKTD3DCA	SFP transceiver GbE 1310 nm 40 km industrial temperature
SFP-GS2LKTD5DCA	SFP transceiver GbE 1550 nm 40 km industrial temperature
SFP-GI2LKTD5DCA	SFP transceiver GbE 1550 nm 80 km industrial temperature
SFP-GL2LKTD5DCA	SFP transceiver GbE 1550 nm 120 km industrial temperature
SFP-MI1LKTD3DCA	SFP transceiver OC48 IR-1 1310 nm 20 km industrial temperature
SFP-MI2LKTD5DCA	SFP transceiver OC48 IR-2 1550 nm 40 km industrial temperature
SFP-ML1LCTD3DCA	SFP transceiver OC48 LR-1 1310 nm 40 km commercial temperature
SFP-ML2LCTD5DCA	SFP transceiver OC48 LR-2 1550 nm 80 km commercial temperature
SFP-ML1LKTD3DCA	SFP transceiver OC48 LR-1 1310 nm 40 km industrial temperature
SFP-ML2LKTD5DCA	SFP transceiver OC48 LR-2 1550 nm 80 km industrial temperature

NORTH AMERICA: 800 498-JDSU (5378)	WORLDWIDE: +800 5378-JDSU	WEBSITE: www.jdsu.com
------------------------------------	---------------------------	---