

60 A VRPower® Smart Power Stage (SPS) Module With Integrated High Accuracy Current and Temperature Monitors

(Datasheet in Brief)

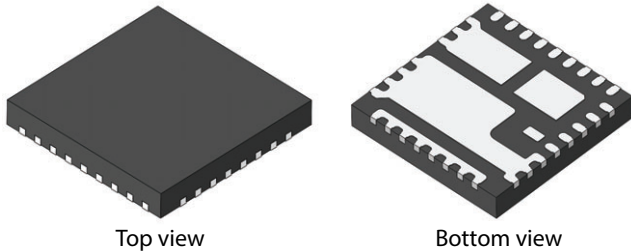

Top view

Bottom view

DESCRIPTION

The SiC648 is a smart VRPower® device that integrates a high side and low side MOSFET, a high performance driver with integrated bootstrap FET. The SiC648 offers high accuracy current and temperature monitors that can be fed back to the controller and doubler to complete a multiphase DC/DC system. They simplify design and increase performance by eliminating the DCR sensing network and associated thermal compensation. Light-load efficiency is supported via a dedicated left control pin. Packaged in Vishay's 5 mm x 5 mm MLP package.

The devices feature a 3.3 V (SiC648A) or 5 V (SiC648) compatible tri-state PWM input that, working together with multiphase PWM controllers, will provide a robust solution in the event of abnormal operating conditions. The SiC648 also improves system performance and reliability with integrated fault protection of UVLO, over-temperature and over-current. An open-drain fault reporting pin simplifies the handshake between the smart VRPower device and multiphase controllers and can be used to disable the controller during start-up and fault conditions.

TYPICAL APPLICATION DIAGRAM

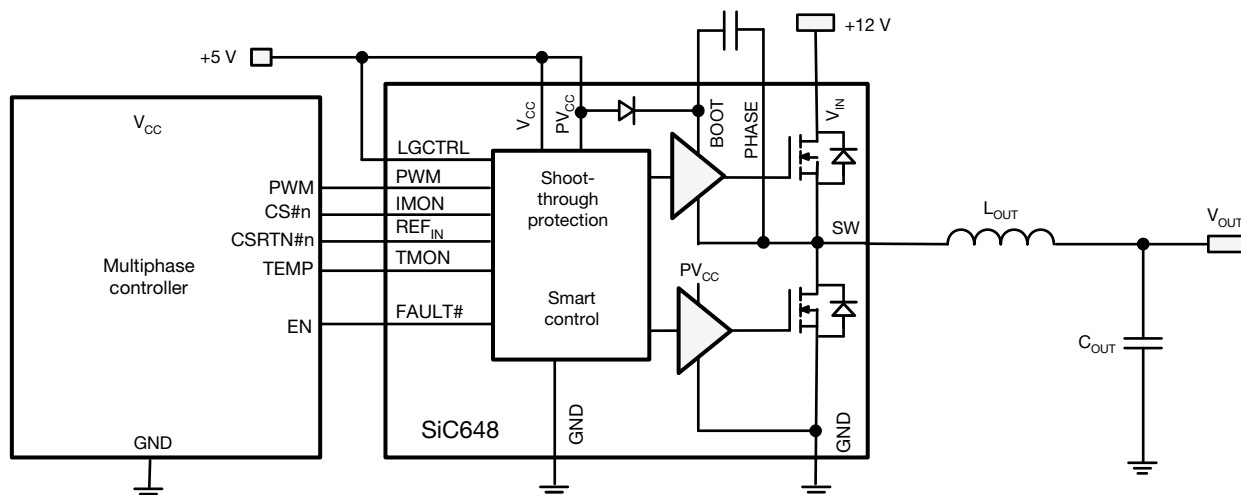

Fig. 1 - Typical Application Block Diagram

FEATURES

- Input range: 4.5 V to 18 V
- Supports 60 A DC current
- Compatible with 3.3 V (SiC648A) and 5 V (SiC648) tri-state PWM
- Down slope current sensing
- $\pm 3\%$ accuracy current monitor (I_{MON}) with REF_{IN} input
- 8 mV/°C temperature monitor with OT flag
- Dedicated low side FET control input
- Fault protection
 - High side FET short and over-current protection
 - Over-temperature protection
 - V_{CC} and V_{IN} under voltage lockout (UVLO)
- Open drain fault reporting output
- Up to 2 MHz switching frequency
- Material categorization: for definitions of compliance please see www.vishay.com/doc?99912



RoHS
COMPLIANT
HALOGEN
FREE

APPLICATIONS

- High frequency and high efficiency VRM and VRD
- Core, graphic, and memory regulators for microprocessors
- High density VR for server, networking, and cloud computing
- POL DC/DC converters and video gaming consoles



PRODUCT SUMMARY		
Part number	SiC648	SiC648A
Description	60 A power stage plus, 4.5 V _{IN} to 18 V _{IN} , 5 V PWM	60 A power stage plus, 4.5 V _{IN} to 18 V _{IN} , 3.3 V PWM
Input voltage min. (V)	4.5	4.5
Input voltage max. (V)	18	18
Continuous current rating max. (A)	60	60
Switch frequency max. (kHz)	2000	2000
Enable (yes / no)	no	no
Monitoring features	T _{MON} , I _{MON}	T _{MON} , I _{MON}
Protection	UVLO, OCP, OTP, HS-short	UVLO, OCP, OTP, HS-short
Light load mode	no	no
Pulse-width modulation (V)	5	3.3
Package type	PowerPAK MLP55-32L	PowerPAK MLP55-32L
Package size (W, L, H) (mm)	5.0 x 5.0 x 0.75	5.0 x 5.0 x 0.75
Status code	1	1
Product type	VRPower (DrMOS)	VRPower (DrMOS)
Applications	Computer, networking	Computer, networking

To request the full version of the datasheet, please contact: ICmarketing@vishay.com

Vishay Siliconix maintains worldwide manufacturing capability. Products may be manufactured at one of several qualified locations. Reliability data for Silicon Technology and Package Reliability represent a composite of all qualified locations. For related documents such as package / tape drawings, part marking, and reliability data, see www.vishay.com/ppg?63049.



Disclaimer

ALL PRODUCT, PRODUCT SPECIFICATIONS AND DATA ARE SUBJECT TO CHANGE WITHOUT NOTICE TO IMPROVE RELIABILITY, FUNCTION OR DESIGN OR OTHERWISE.

Vishay Intertechnology, Inc., its affiliates, agents, and employees, and all persons acting on its or their behalf (collectively, "Vishay"), disclaim any and all liability for any errors, inaccuracies or incompleteness contained in any datasheet or in any other disclosure relating to any product.

Vishay makes no warranty, representation or guarantee regarding the suitability of the products for any particular purpose or the continuing production of any product. To the maximum extent permitted by applicable law, Vishay disclaims (i) any and all liability arising out of the application or use of any product, (ii) any and all liability, including without limitation special, consequential or incidental damages, and (iii) any and all implied warranties, including warranties of fitness for particular purpose, non-infringement and merchantability.

Statements regarding the suitability of products for certain types of applications are based on Vishay's knowledge of typical requirements that are often placed on Vishay products in generic applications. Such statements are not binding statements about the suitability of products for a particular application. It is the customer's responsibility to validate that a particular product with the properties described in the product specification is suitable for use in a particular application. Parameters provided in datasheets and / or specifications may vary in different applications and performance may vary over time. All operating parameters, including typical parameters, must be validated for each customer application by the customer's technical experts. Product specifications do not expand or otherwise modify Vishay's terms and conditions of purchase, including but not limited to the warranty expressed therein.

Except as expressly indicated in writing, Vishay products are not designed for use in medical, life-saving, or life-sustaining applications or for any other application in which the failure of the Vishay product could result in personal injury or death. Customers using or selling Vishay products not expressly indicated for use in such applications do so at their own risk. Please contact authorized Vishay personnel to obtain written terms and conditions regarding products designed for such applications.

No license, express or implied, by estoppel or otherwise, to any intellectual property rights is granted by this document or by any conduct of Vishay. Product names and markings noted herein may be trademarks of their respective owners.