

Document No.	
ECN No.	
Date of Issue	September 1987
Status	Preliminary Specification
RF Communications	

UAA2033T

Low power digital paging receiver

GENERAL DESCRIPTION

The UAA2033T is a very low power radio receiver circuit for use in VHF paging receivers (30 to 174 MHz) of wide-area digital paging systems employing direct FM non-return-to-zero (NRZ) frequency-shift keying (FSK) modulation.

Used in conjunction with the PCA5000T decoder for POCSAG paging systems, it offers an extremely advanced radio paging concept.

The receiver design is based on the offset receiver principle which gives improved performance, lower power consumption and requires less external components than the two-branch type of receiver architecture found in presently available ICs. The receiver provides fully filtered and squared data to drive the decoder device and can be turned off completely by external inputs.

Features

- Wide operating supply voltage range
- Low current consumption
- Fully compatible with world-wide POCSAG paging systems
- Receiver power externally addressable
- High sensitivity
- Low battery voltage detector
- Uses low cost crystal
- Automatically tracks offsets in the input frequency

QUICK REFERENCE DATA

parameter	conditions	symbol	min.	typ.	max.	unit
Supply voltage		$V_P = V_{14-15}$	2,0	2,7	3,5	V
Supply current		I_{14}	2,2	2,7	3,3	mA
Sensitivity	10^{-2} bit error rate	EMF/2	—	—	0,3	μV
Operating ambient temperature range		T_{amb}	-10	—	+70	$^{\circ}C$

PACKAGE OUTLINE

28-lead mini-pack; plastic (SO28; SOT136A).

Low power digital paging receiver

UAA2033T

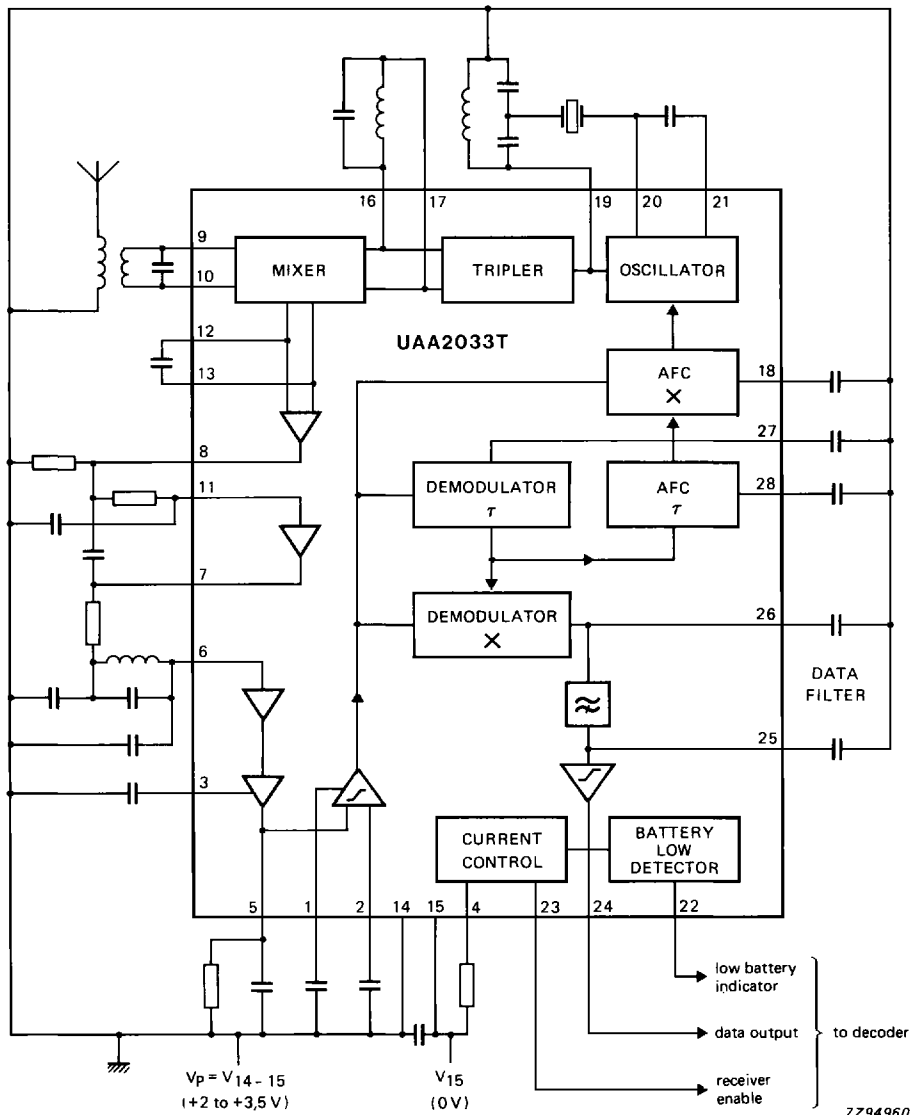

Fig. 1 Block diagram.

Low power digital paging receiver

UAA2033T

PINNING

pin	description
1	low frequency filter '3' (limiter decoupling '2')
2	low frequency filter '2' (limiter decoupling '1')
3	low frequency filter '1'
4	current control (internal reference)
5	IF filter
6	IF filter
7	IF filter
8	IF filter
9	mixer input '2'
10	mixer input '1'
11	IF filter
12	mixer output 'B'
13	mixer output 'A'
14	supply voltage (positive)
15	supply voltage (negative)
16	tripler coil '2'
17	tripler coil '1'
18	AFC '2'
19	oscillator output
20	oscillator input
21	oscillator AFC range
22	low battery voltage indicator
23	receiver enable
24	data output
25	data filter '2'
26	data filter '1'
27	demodulator centre frequency
28	AFC '1'

RATINGS

Limiting values in accordance with the Absolute Maximum System (IEC 134)

parameter	symbol	min.	max.	unit
Supply voltage	$V_p = V_{14-15}$	-0,3	8,0	V
Operating ambient temperature range	T_{amb}	-10	+70	°C
Storage temperature range	T_{stg}	-55	+125	°C

Low power digital paging receiver

UAA2033T

DC CHARACTERISTICS

$V_p = 2,0$ to $3,5$ V; $T_{amb} = -10$ to $+70$ °C; typical values measured at $T_{amb} = 25$ °C, $V_p = 2,7$ V; test circuit as Fig. 3 with L4 short circuited, no RF input and crystal XL1 removed

parameter	conditions	symbol	min.	typ.	max.	unit
Supply voltage		$V_p = V_{14-15}$	2,0	2,7	3,5	V
Supply current	pin 23 = HIGH	I_{14}	2,2	2,7	3,3	mA
	pin 23 = LOW	I_{14}	—	—	1,0	μ A
Receiver enable (pin 23)						
Input voltage HIGH		V_{23-15}	$V_p - 0,6$	—	—	V
Input voltage LOW	$I_{14} = 1 \mu$ A	V_{23-15}	—	—	0,4	V
Input current HIGH		I_{23}	—	+1	—	μ A
Input current LOW		I_{23}	—	-1	—	μ A
Data output (pin 24)						
Output voltage HIGH		V_{24-15}	$V_p - 0,7$	—	—	V
Output voltage LOW	$I_{24} = \pm 10 \mu$ A	V_{24-15}	—	—	0,5	V
Low battery voltage indicator (pin 22)						
Detection voltage	note 1	V_{DET}	2,035	2,135	2,235	V
Output voltage HIGH	$I_{22} = \pm 5 \mu$ A	V_{22-15}	$V_p - 0,5$	—	—	V
Output voltage LOW	$I_{22} = \pm 5 \mu$ A	V_{22-15}	—	—	0,5	V

AC CHARACTERISTICS

$V_p = 2,0$ to $3,5$ V; $T_{amb} = -10$ to $+70$ °C; typical values measured at $T_{amb} = 25$ °C, $V_p = 2,7$ V; test circuit as Fig. 3 with $f = 173,950$ MHz; channel spacing = 25 kHz; deviation = $\pm 4,5$ kHz; bit rate = 512 b/s (256 Hz square wave); AFC frequency limits 173,948 and 173,952 MHz; see Tuning Procedure

parameter	conditions	symbol	min.	typ.	max.	unit
RF sensitivity and AFC performance						
Sensitivity for 10^{-2} bit error rate (note 2)	$T_{amb} = 25$ °C	EMF/2	—	—	0,30	μ V
	$T_{amb} = -10$ to $+70$ °C	EMF/2	—	—	0,43	μ V
Bit error rate	EMF/2 = 1 μ V	BER	—	10^{-3}	—	
Data output (pin 24)						
Duty factor	EMF/2 = 100 μ V; $f = 174$ MHz	δ	35	—	55	%
Transition time	EMF/2 = 100 μ V; $f = 174$ MHz; $R_L = 1$ M Ω ; $C_L = 100$ pF	t_T	—	—	50	μ s

Low power digital paging receiver

UAA2033T

Notes to the characteristics

1. V_{22-15} goes HIGH if V_p is less than V_{DET} .
2. Sensitivity measurement.

A simple digital method of performing an approximate bit error rate (BER) measurement with a counter is shown in Fig. 2. At high signal levels ($10 \mu V$) the counter should read the exact frequency of the data input to the signal generator. As the signal level is reduced, errors occur at the receiver output and effectively increase the output frequency read by the counter (error duration is nearly always less than a bit length).

For a bit error rate of 1 in a 100 on a 512 b/s system, the counted frequency will increase from 256 Hz at high signal levels to 261 Hz when the input signal level is reduced to the 1 in a 100 BER point.

Tuning procedure for AC tests

1. After performing the DC tests, set up the device in the AC test circuit as per Fig. 3.
2. Connect pin 18 to a voltage source of $V_{18-14} = -0,59 V$. Measure the oscillator frequency with a counter connected to the link winding of L3.
Tune C21 (crystal frequency trimmer) to set the crystal oscillator to a frequency of:

$$\frac{\text{received frequency} + 2 \text{ kHz}}{3} \pm 100 \text{ Hz.}$$

For a received frequency of 173,950 MHz the oscillator frequency is 57,984 MHz.

3. Remove test voltage source and turn on the signal generator ($f = 173,950 \text{ MHz}$, deviation = $\pm 4,5 \text{ kHz}$, 256 Hz square-wave modulation, RF input level = 3 mV).

Monitor the audio amplitude at pin 5 using an oscilloscope with an AC sensitivity of at least 2 mV per division.

Note that in the following tests the RF signal generator level should be reduced as the receiver is tuned to ensure that the peak-to-peak audio output voltage at pin 5 lies between 20 mV and 100 mV.

4. Tune C22 (tripler) to obtain peak audio output voltage at pin 5. The tuning will be found to have a discontinuity on one side of the peak response, i.e. the level will drop much faster on one side of the peak than on the other. Therefore when setting C22 ensure that it is not set too close to the discontinuity.
5. Tune C3 (mixer input) to obtain a peak audio output on pin 5.
6. Disconnect the frequency counter from the oscillator output. Measure the voltage on pin 18 and check that it is within the range $-0,57$ to $-0,61 V$. If it is outside this range then adjust C21 (oscillator trimmer) until it comes within the limits.
7. Check with an oscilloscope that clean data is appearing on DATA OUTPUT (pin 24) and proceed with the AC tests.

Low power digital paging receiver**UAA2033T**

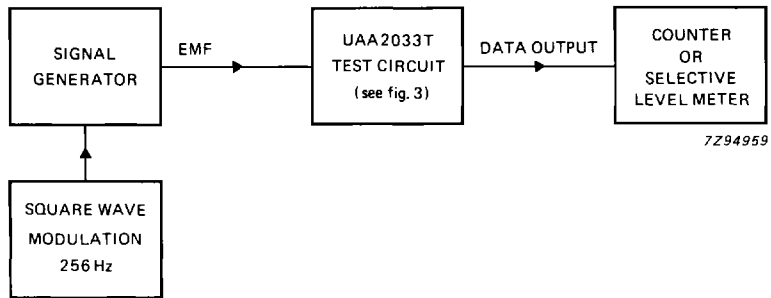

Fig. 2 Bit error rate measurement: signal generator frequency (f) = 173,95 MHz ;
input impedance of counter or selective level meter greater than 100 k Ω .

Low power digital paging receiver

UAA2033T

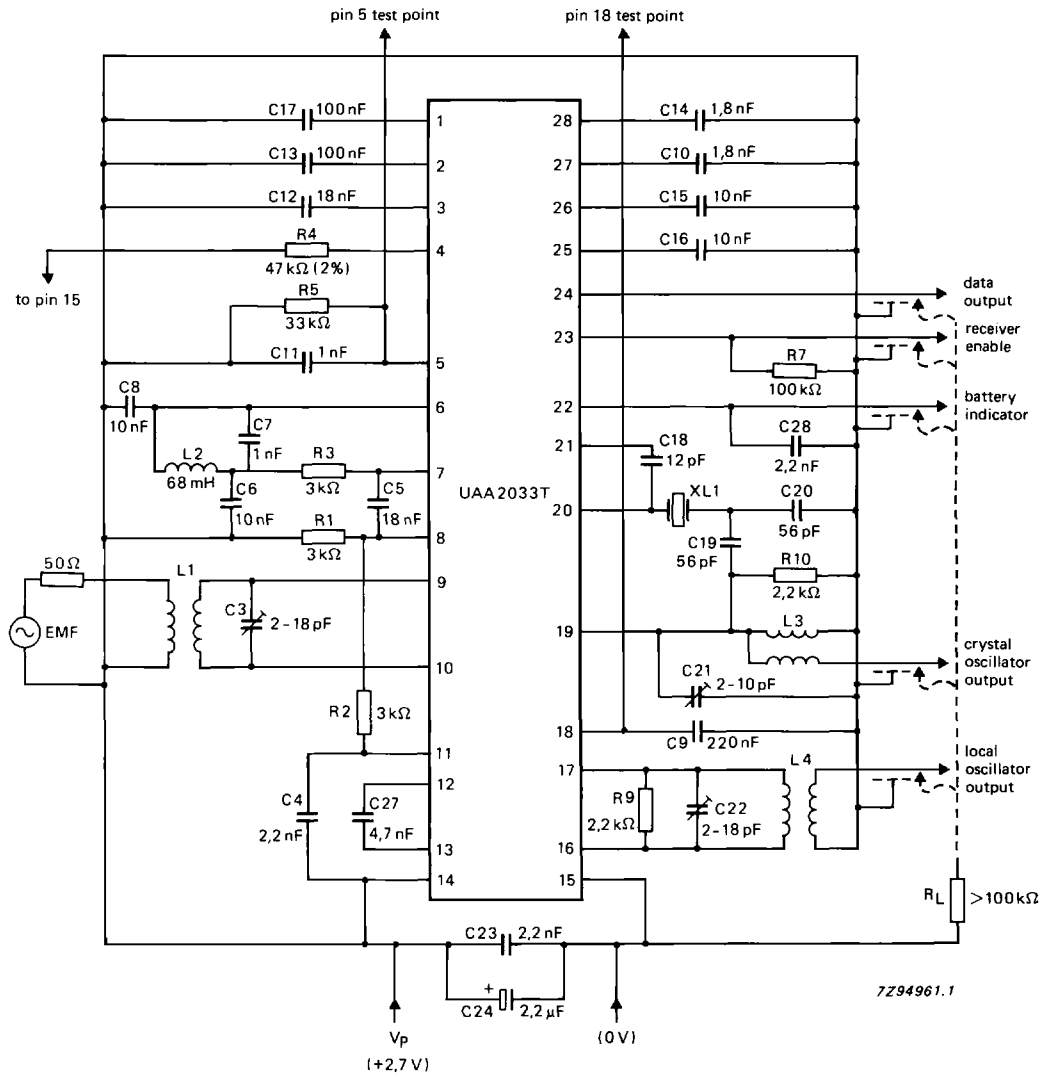

Fig. 3 Test circuit.

Coil data

L1, L3 and L4 wound with 0,315 mm enamelled wire on Toko ϕ 4,5 mm diameter former without pot or core. Screening cans also used.

L1 – 4 turns, one turn/groove. Link winding, 2 turns over the centre of the other winding.

L3 – 6 turns, 2 turns/groove. Link winding, 1 turn at bottom of former.

L4 – 3 turns, 1 turn/groove. Link winding, 1 turn at bottom of former.

L2 – 68 mH inductor. At 10 kHz minimum Q = 10.

Crystal (XL1) frequency 57985,90 kHz