



FH1

High Dynamic Range FET

Product Features

- 50 – 4000 MHz
- Low Noise Figure
- 18 dB Gain
- +42 dBm OIP3
- +21 dBm P1dB
- Single or Dual Supply Operation
- Lead-free/Green/RoHS-compliant SOT-89 Package
- MTTF > 100 years

Applications

- Mobile Infrastructure
- CATV / DBS
- W-LAN / ISM
- Defense / Homeland Security

Specifications ⁽¹⁾

DC Electrical Parameter	Units	Min	Typ	Max
Saturated Drain Current, Idss ⁽²⁾	mA	100	140	170
Transconductance, Gm	mS		120	
Pinch-off Voltage, Vp ⁽³⁾	V	-3	-1.5	

RF Parameter	Units	Min	Typ	Max
Operational Bandwidth	MHz	50 – 4000		
Test Frequency	MHz	800		
Small-signal Gain, Gss	dB	17	18	
Max Stable Gain, Gmsg	dB		23	
Output IP3 ⁽⁴⁾	dBm	+38	+42	
P1dB	dBm		+21	
Minimum Noise Figure ⁽⁵⁾	dB		0.77	
Drain Bias	V		+5	
Gate Bias	V		0	

- DC and RF parameters are measured under the following conditions unless otherwise noted: 25 °C with Vds = 5V, Vgs = 0V, in a 50 Ω system.
- Idss is measured with Vgs = 0V.
- Pinch-off voltage is measured with Ids = 0.6 mA.
- 3OIP measured with two tones at an output power of +5 dBm/tone separated by 10 MHz. The suppression on the largest IM3 product is used to calculate the 3OIP using a 2:1 rule.
- The minimum noise figure has $\Gamma_S = \Gamma_L = \Gamma_{OPT}$.

Absolute Maximum Rating

Parameter	Rating
Storage Temperature	-55 to +150 °C
Drain to Source Voltage	+7 V
Gate to Source Voltage	-6 V
Gate Current	4.5 mA
RF Input Power (continuous)	4 dB above Input P1dB
Junction Temperature	+160 °C
Thermal Resistance, Rth ⁽¹⁾	85 °C / W

Operation of this device above any of these parameters may cause permanent damage.

Product Description

The FH1 is a high dynamic range FET packaged in a low-cost surface-mount package. The combination of low noise figure and high output IP3 at the same bias point makes it ideal for receiver and transmitter applications. The device combines dependable performance with superb quality to maintain MTTF values exceeding 100 years at mounting temperatures of +85 °C. The FH1 is available the environmentally-friendly lead-free/green/RoHS-compliant SOT-89 package.

The device utilizes a high reliability GaAs MESFET technology and is targeted for applications where high linearity is required. It is well suited for various current and next generation wireless technologies such as GPRS, GSM, CDMA, and W-CDMA. In addition, the FH1 will work for other applications within the 50 to 4000 MHz frequency range such as fixed wireless.

Functional Diagram

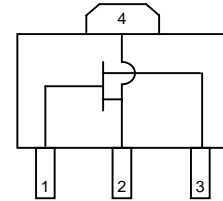

Function	Pin No.
Gate	1
Drain	3
Source	2, 4

Typical Performance ⁽⁶⁾

Parameter	Units	Typical		
Frequency	MHz	900	1960	2140
S21	dB	19	16.5	16.5
S11	dB	-11	-20	-22
S22	dB	-10	-9	-9
Output IP3 ⁽⁴⁾	dBm	+42	+40	+40
Output P1dB	dBm	+21.8	+22.1	+22.1
Noise Figure	dB	2.7	3.1	3.0
Drain Bias		5V @ 140mA		
Gate Voltage	V	0		

6. The device requires appropriate matching to become unconditionally stable. Parameters reflect performance in an appropriate application circuit.

Ordering Information

Part No.	Description
FH1-G	High Dynamic Range FET (lead-free/green/RoHS-compliant SOT-89 package)

Specifications and information are subject to change without notice.



Typical Device Data

Data is shown at a biasing configuration of $V_{DS} = +5\text{ V}$, $I_{DS} = 140\text{ mA}$, $25\text{ }^\circ\text{C}$ for the unmatched device in a 50 ohm system)

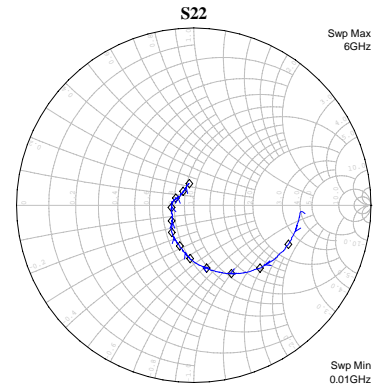
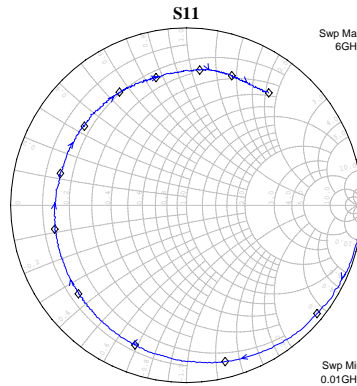
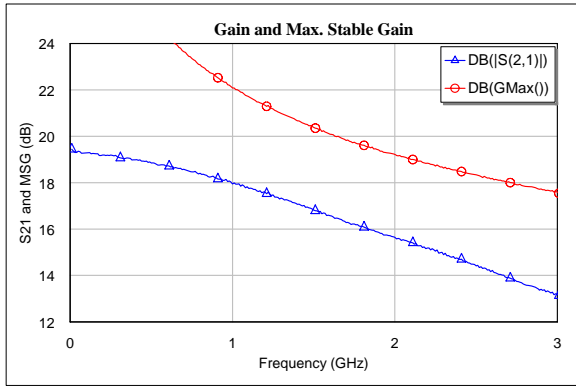

Notes:

The gain for the unmatched device in 50 ohm system is shown as the trace in blue color. For a tuned circuit for a particular frequency, it is expected that actual gain will be higher, as high as the maximum stable gain. The maximum stable gain is shown in the red line. The impedance plots are shown from 10 – 6000 MHz, with markers placed at 0.5 – 6.0 GHz in 0.5 GHz increments.

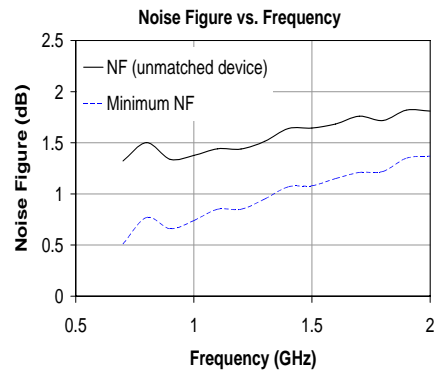
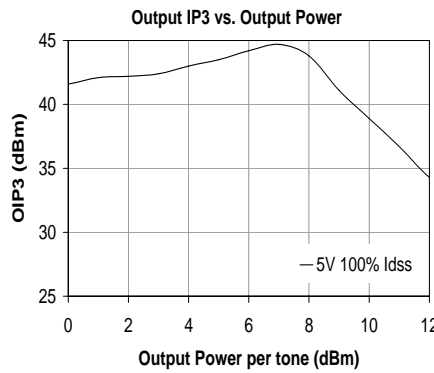
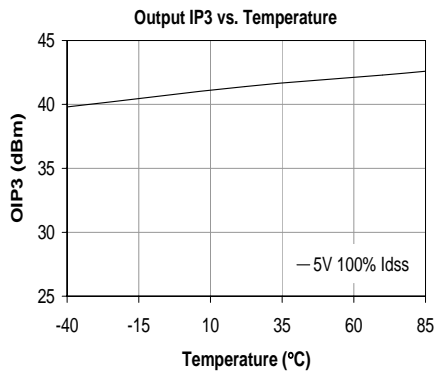

S-Parameters ($V_D = +5\text{ V}$, $I_D = 140\text{ mA}$, $V_G = 0\text{ V}$, $25\text{ }^\circ\text{C}$, calibrated to device leads)

Freq (MHz)	S11 (dB)	S11 (ang)	S21 (dB)	S21 (ang)	S12 (dB)	S12 (ang)	S22 (dB)	S22 (ang)
50	0.00	-4.08	19.36	176.06	-51.05	87.96	-4.38	-3.34
250	-0.13	-19.64	19.19	164.65	-37.15	78.37	-4.52	-11.51
500	-0.34	-39.41	18.85	150.19	-31.34	66.75	-4.77	-22.43
750	-0.55	-58.33	18.47	136.21	-28.24	55.74	-5.19	-33.05
1000	-0.83	-75.93	17.95	123.24	-26.22	45.25	-5.77	-43.46
1250	-1.16	-93.29	17.47	110.92	-24.88	35.22	-6.44	-53.09
1500	-1.50	-110.36	16.82	99.18	-23.95	26.69	-7.14	-61.08
1750	-1.80	-125.64	16.21	88.19	-23.27	18.17	-7.94	-69.92
2000	-2.03	-140.92	15.65	77.53	-22.81	9.87	-8.84	-78.43
2250	-2.25	-155.64	15.05	67.15	-22.39	2.11	-9.57	-86.41
2500	-2.37	-169.80	14.42	57.62	-22.25	-4.68	-10.43	-93.92
2750	-2.55	-177.26	13.74	48.11	-22.08	-11.35	-11.43	-101.88
3000	-2.62	-165.93	13.18	39.86	-22.01	-17.16	-12.30	-108.95

Noise Parameters ($V_D = +5\text{ V}$, $I_D = 140\text{ mA}$, $V_G = 0\text{ V}$, $25\text{ }^\circ\text{C}$, calibrated to device leads)

Freq (MHz)	NF_min (dB)	MagOpt (mag)	AngOpt (deg)	Rn
700	0.51	0.574	32.8	0.403
800	0.77	0.535	37.4	0.409
900	0.66	0.508	44.1	0.379
1000	0.74	0.488	50.4	0.365
1100	0.85	0.463	56.4	0.357
1200	0.85	0.458	62.0	0.345
1300	0.95	0.446	67.3	0.335
1400	1.07	0.450	73.3	0.323

Device S-parameters and noise are available for download off of the website at: <http://www.wj.com>

Specifications and information are subject to change without notice.

Reference Design: 35 MHz, 17 dB Gain

Frequency	MHz	30	35	40
Gain	dB	16.6	16.8	16.8
S11	dB	-19	-20	-13
S22	dB	-21	-16	-14
P1dB	dBm	+21		
OIP3	dBm	+39		
Noise Figure	dB	4.0	3.4	3.2
Supply Voltage	V	+5		
Supply Current	mA	140		

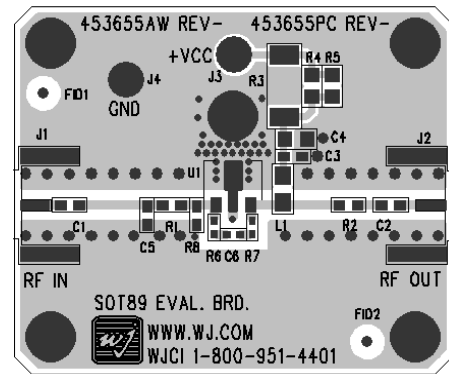
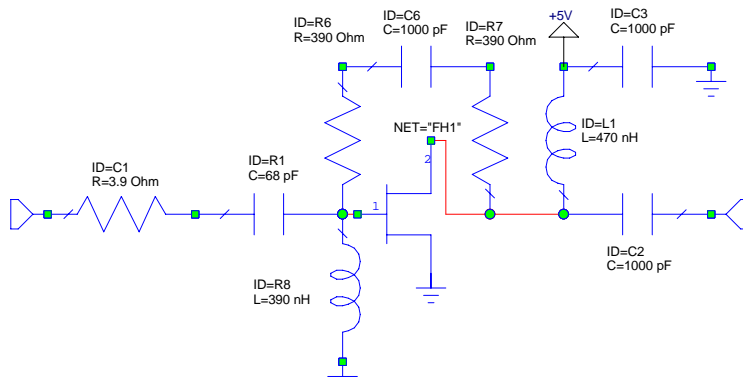
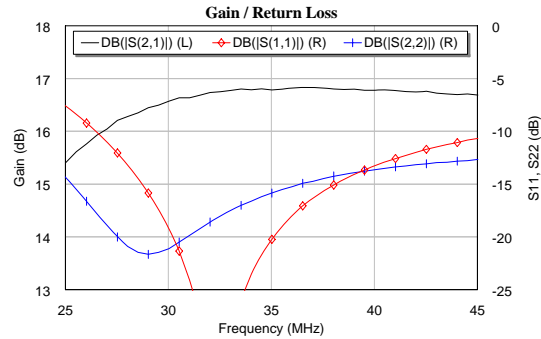

- Notes:
1. Circuit Board Material: .014" Getek ML200DSS ($\epsilon_r = 4.2$), 1 oz copper. The main microstrip line has a line impedance of 50 Ω .
 2. Components not shown in the schematic are either not used or loaded with a thru. Gain for the circuit can be adjusted slightly with the modification of the feedback resistance.

Reference Design: 170 MHz, 14 dB Gain

Frequency	MHz	160	170	180
Gain	dB	14.1	14.2	14.3
S11	dB	-25	-33	-28
S22	dB	-21	-23	-26
P1dB	dBm	+21.6		
OIP3	dBm	+42		
Noise Figure	dB	2.7	2.7	2.7
Supply Voltage	V	+5		
Supply Current	mA	140		

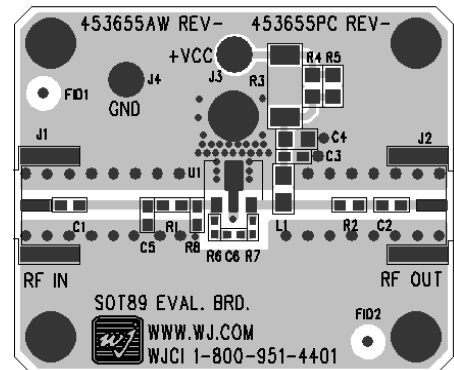
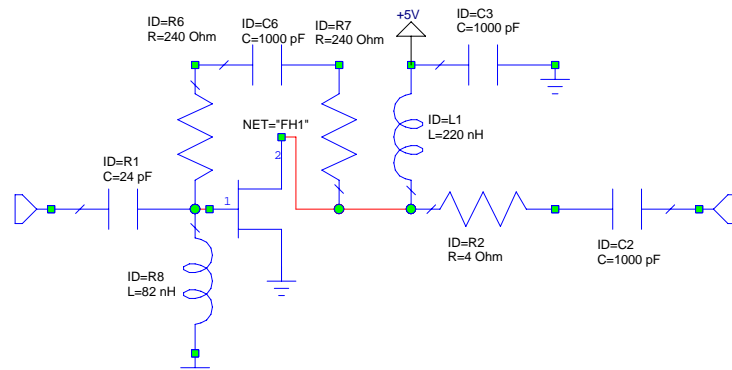
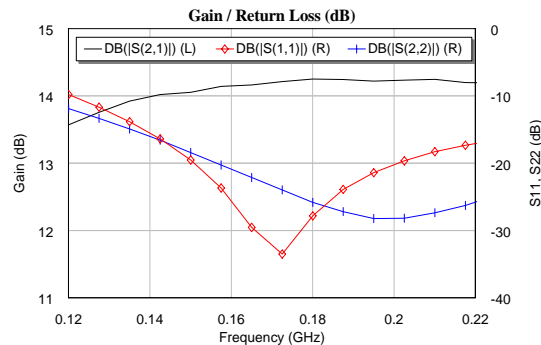

- Notes:
1. Circuit Board Material: .014" Getek ML200DSS ($\epsilon_r = 4.2$), 1 oz copper. The main microstrip line has a line impedance of 50 Ω .
 2. Components not shown in the schematic are either not used or loaded with a thru. Gain for the circuit can be adjusted slightly with the modification of the feedback resistance.

Specifications and information are subject to change without notice.



FH1

High Dynamic Range FET

Reference Design: 260 MHz, 25 dB Gain

Frequency	MHz	250	260	270
Gain	dB	25.2	25.1	24.9
S11	dB	-23	-22	-13
S22	dB	-12	-14	-17
P1dB	dBm	+22.4		
OIP3	dBm	+39.5		
Noise Figure	dB	1.8	1.9	2.1
Supply Voltage	V	+5		
Supply Current	mA	140		

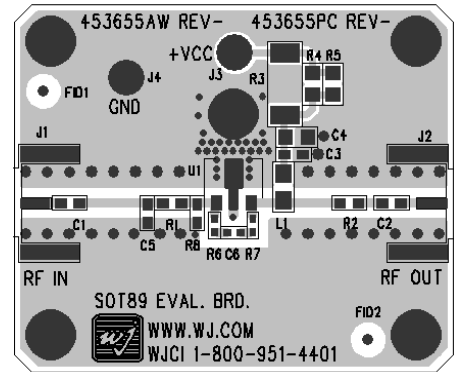
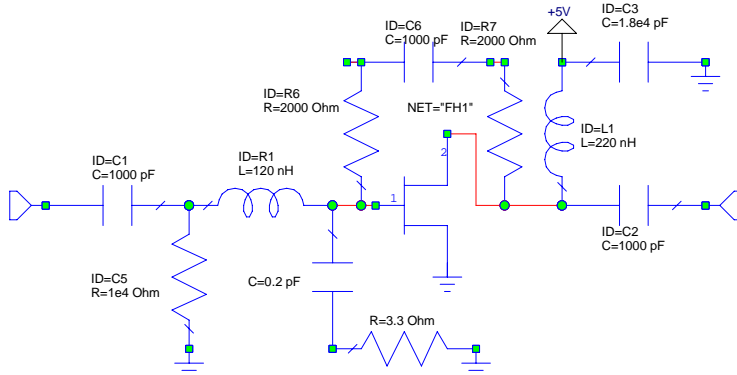
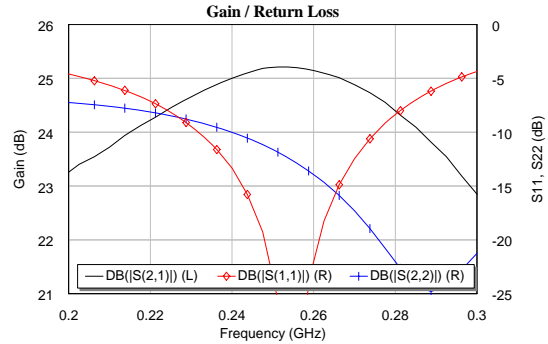

Notes:

1. Circuit Board Material: .014" Getek ML200DSS ($\epsilon_r = 4.2$), 1 oz copper. The main microstrip line has a line impedance of 50 Ω .
2. Components not shown in the schematic are either not used or loaded with a thru. Gain for the circuit can be adjusted slightly with the modification of the feedback resistance.

Reference Design: 460 MHz, 20 dB Gain

Frequency	MHz	450	460	470
Gain	dB	19.9	19.9	19.9
S11	dB	-24	-24	-21
S22	dB	-16	-15	-15
P1dB	dBm	+21.6		
OIP3	dBm	+42		
Noise Figure	dB	1.95	2.08	2.17
Supply Voltage	V	+5		
Supply Current	mA	140		

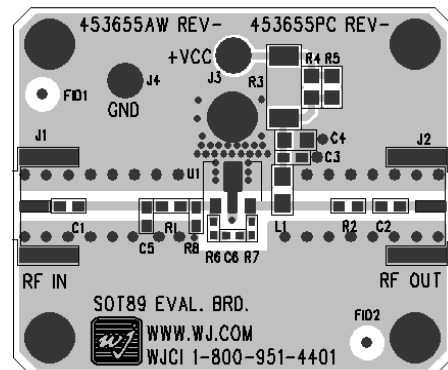
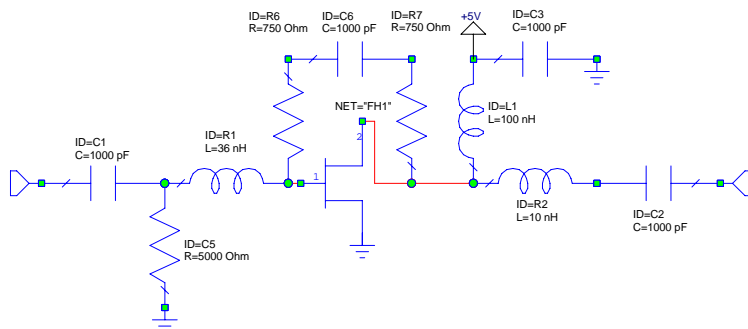
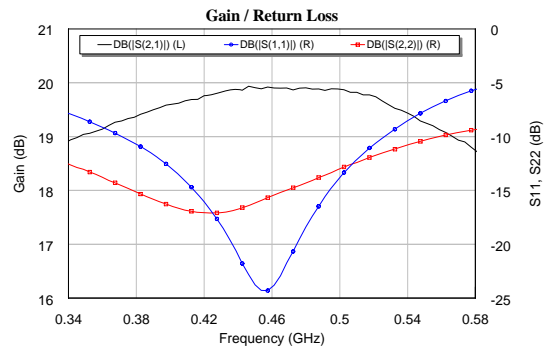

Notes:

1. Circuit Board Material: .014" Getek ML200DSS ($\epsilon_r = 4.2$), 1 oz copper. The main microstrip line has a line impedance of 50 Ω .
2. Components not shown in the schematic are either not used or loaded with a thru. Gain for the circuit can be adjusted slightly with the modification of the feedback resistance.

Specifications and information are subject to change without notice.

Reference Design: 790 MHz, 19 dB Gain

Frequency	GHz	746	790	835
Gain	dB	19.2	19.4	19.3
S11	dB	-20	-28	-15
S22	dB	-22	-23	-22
P1dB	dBm	+22		
OIP3	dBm	+41		
Noise Figure	dB	2.3		
Supply Voltage	V	+5		
Supply Current	mA	140		

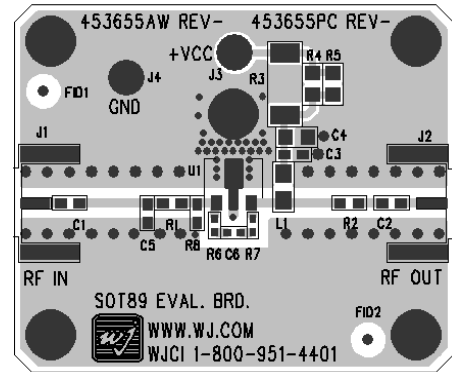
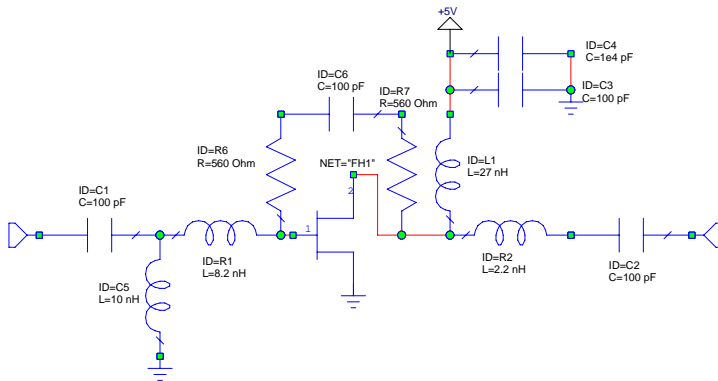
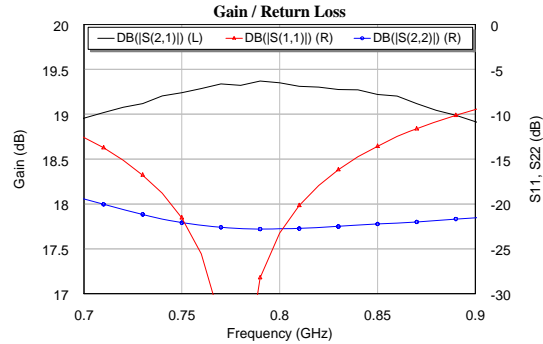

- Notes:
1. Circuit Board Material: .014" Getek ML200DSS (er = 4.2), 1 oz copper. The main microstrip line has a line impedance of 50 Ω .
 2. Components not shown in the schematic are either not used or loaded with a thru. Gain for the circuit can be adjusted slightly with the modification of the feedback resistance.

Reference Design: 790 MHz, 17 dB Gain

Frequency	GHz	746	790	835
Gain	dB	17.3	17.4	17.4
S11	dB	-19	-19	-16
S22	dB	-22	-22	-21
P1dB	dBm	+22		
OIP3	dBm	+41		
Noise Figure	dB	2.0	2.1	2.2
Voltage	V	+5		
Current	mA	140		

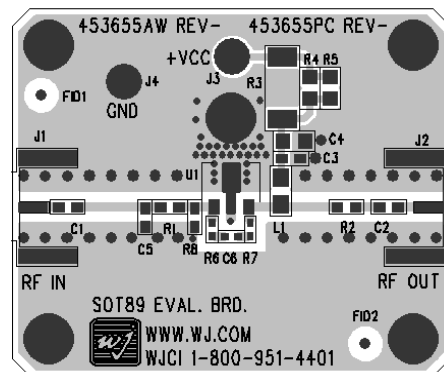
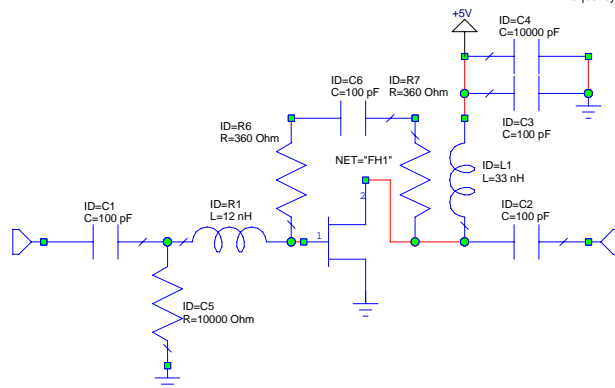
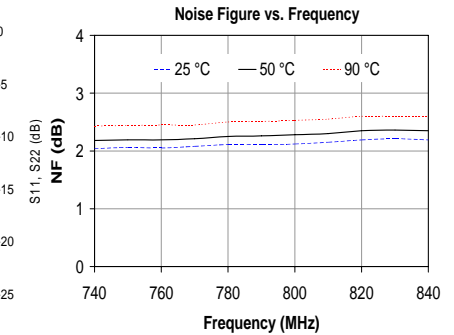
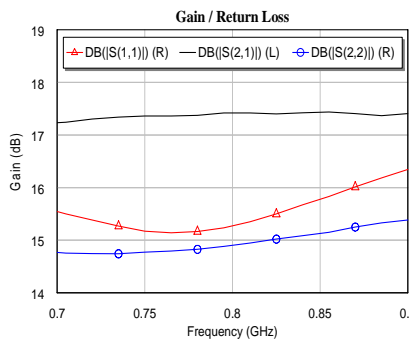

- Notes:
1. Circuit Board Material: .014" Getek ML200DSS (er = 4.2), 1 oz copper. The main microstrip line has a line impedance of 50 Ω .
 2. Components not shown in the schematic are either not used or loaded with a thru. Gain for the circuit can be adjusted slightly with the modification of the feedback resistance.

Specifications and information are subject to change without notice.



FH1

High Dynamic Range FET

Reference Design: 880 MHz, 18 dB Gain

Frequency	GHz	850	875	900
Gain	dB	17.95	17.96	18.00
S11	dB	-16	-15	-15
S22	dB	-23	-22	-22
P1dB	dBm	+22		
OIP3	dBm	+41		
Noise Figure	dB	1.8	1.83	1.85
Supply Voltage	V	+5		
Supply Current	mA	140		

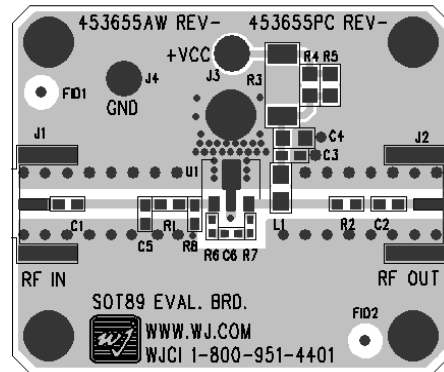
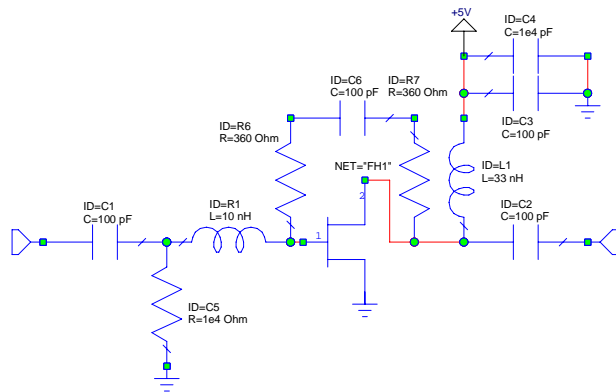
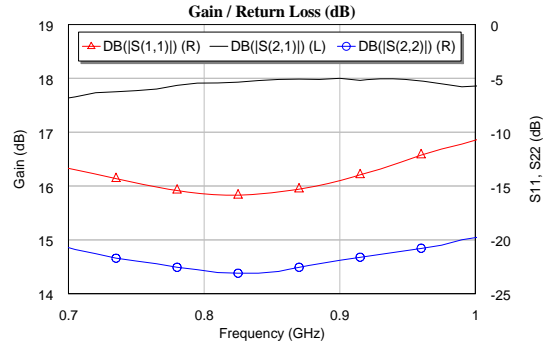

Notes:

1. Circuit Board Material: .014" Getek ML200DSS (er = 4.2), 1 oz copper. The main microstrip line has a line impedance of 50 Ω.
2. Components not shown in the schematic are either not used or loaded with a thru. Gain for the circuit can be adjusted slightly with the modification of the feedback resistance.

Reference Design: 800 - 2200 MHz, 15 dB Gain

Frequency	GHz	900	1900	2140
Gain	dB	14.9	16.3	16.4
S11	dB	-22	-10	-18
S22	dB	-14	-9.7	-9.6
P1dB	dBm	+22.1	+22.4	+22.1
OIP3	dBm	+40.7	+42.0	+41.0
Noise Figure	dB	2.4	2.6	2.8
Supply Voltage	V	+5		
Supply Current	mA	140		

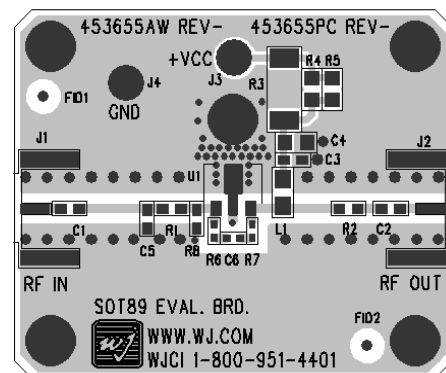
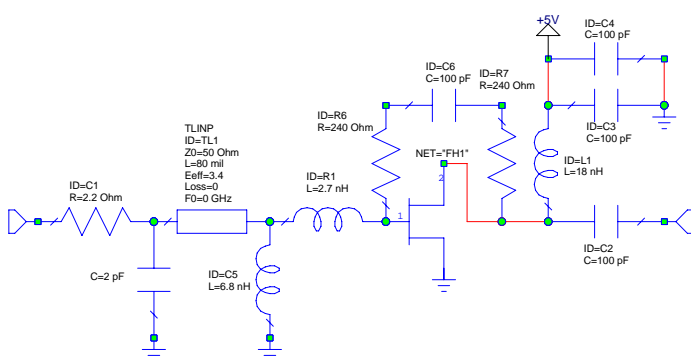
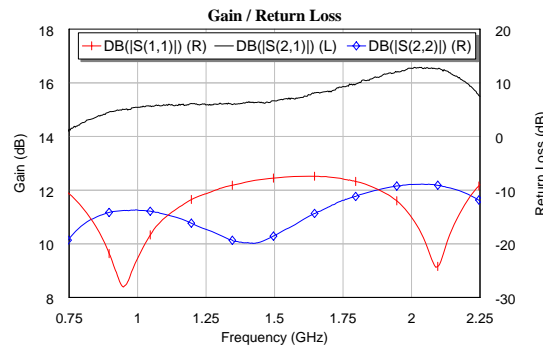

Notes:

1. Circuit Board Material: .014" Getek ML200DSS (er = 4.2), 1 oz copper. The main microstrip line has a line impedance of 50 Ω.
2. Components not shown in the schematic are either not used or loaded with a thru. Gain for the circuit can be adjusted slightly with the modification of the feedback resistance.
3. A dc blocking capacitor needs to be placed before C1 if dc is present at the input of the circuit.

Specifications and information are subject to change without notice.

FH1-G Mechanical Information

This package is lead-free/Green/RoHS-compliant. The plating material on the leads is NiPdAu. It is compatible with both lead-free (maximum 260 °C reflow temperature) and leaded (maximum 245 °C reflow temperature) soldering processes.

Outline Drawing

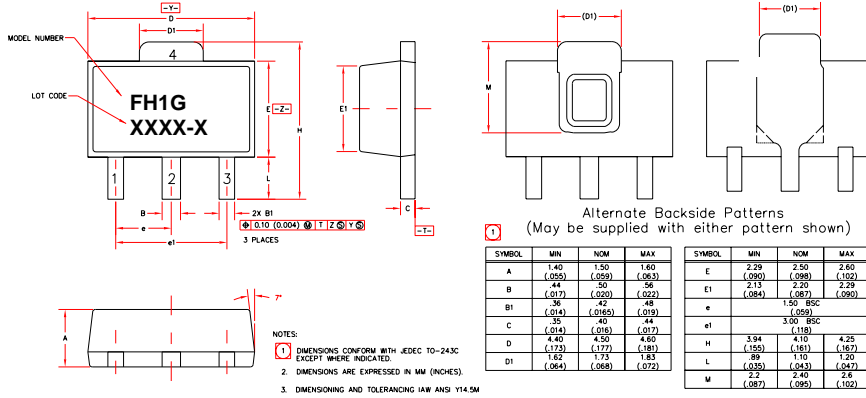

Land Pattern

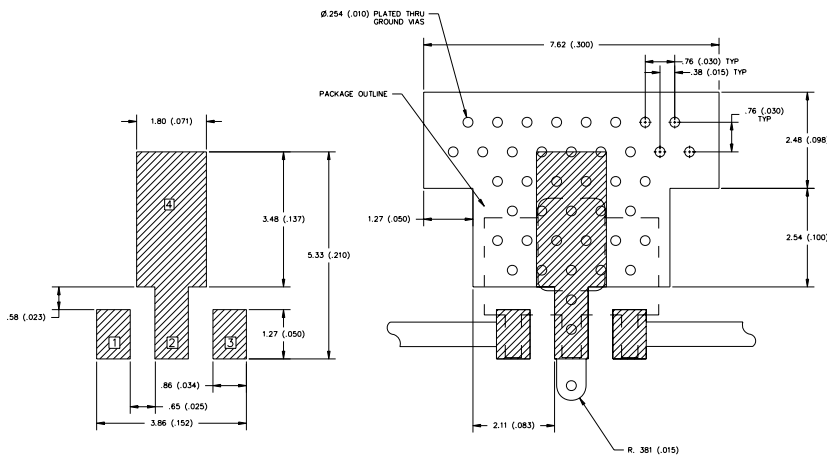

Product Marking

The FH1-G will be marked with an “FH1G” designator. An alphanumeric lot code (“XXXX-X”) is also marked below the part designator on the top surface of the package. The obsolete tin-lead package is marked with an “FH1” designator followed by an alphanumeric lot code.

Tape and reel specifications for this part are located on the website in the “Application Notes” section.

MSL / ESD Rating



Caution! ESD sensitive device.

ESD Rating: Class 1B
 Value: Passes $\geq 500V$ to $<1000V$
 Test: Human Body Model (HBM)
 Standard: JEDEC Standard JESD22-A114

ESD Rating: Class IV
 Value: Passes $\geq 1000V$ to $<2000V$
 Test: Charged Device Model (CDM)
 Standard: JEDEC Standard JESD22-C101

MSL Rating: Level 3 at $+260\text{ }^\circ\text{C}$ convection reflow
 Standard: JEDEC Standard J-STD-020

Mounting Config. Notes

- Ground / thermal vias are critical for the proper performance of this device. Vias should use a .35mm (#80 / .0135”) diameter drill and have a final plated thru diameter of .25 mm (.010”).
- Add as much copper as possible to inner and outer layers near the part to ensure optimal thermal performance.
- Mounting screws can be added near the part to fasten the board to a heatsink. Ensure that the ground / thermal via region contacts the heatsink.
- Do not put solder mask on the backside of the PC board in the region where the board contacts the heatsink.
- RF trace width depends upon the PC board material and construction.
- Use 1 oz. Copper minimum.
- All dimensions are in millimeters (inches). Angles are in degrees.