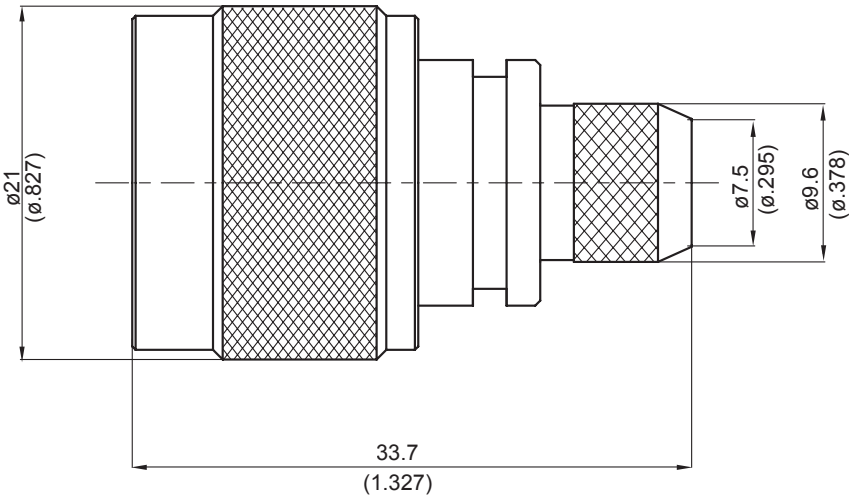

N3100-0011	N Plug Crimp	75Ω
		
Parts	Material	Plating (Micro-inch)
Ferrule	Brass	Tin-Zinc-Copper-Alloy 100 Over Copper 50
Contact Pin	Brass	Gold 5 Over Nickel 50 Over Copper 50
Retainer Ring	Brass	Tin-Zinc-Copper-Alloy 100 Over Copper 50
Gasket	Silicon	
Insulator	Teflon	
Contact Body	Brass	Tin-Zinc-Copper-Alloy 100 Over Copper 50
Body	Brass	Tin-Zinc-Copper-Alloy 100 Over Copper 50
Coupling Nut	Brass	Tin-Zinc-Copper-Alloy 100 Over Copper 50
Weight: 33.44 g Suitable Cables: RG11		

This part number complies with RoHS.

Notice: JYEBAO reserves the right to make modifications deemed appropriate.

CABLE ASSEMBLY INSTRUCTION

N3100-0011

JYE BAO CO., LTD.

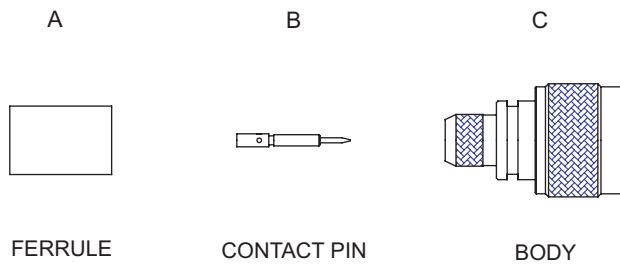

DIAGRAM	ASSEMBLY INSTRUCTION
	<p>Step 1: STRIP AS SHOWN.</p>
	<p>Step 2: SLIDE FERRULE "A" OVER CABLE. Step 3: PUT PIN "B" ON CENTER CONDUCTOR AND SOLDER IN "Y".</p>
	<p>Step 4: LOOSEN BRAIDING AND SLIDE CONNECTOR "C" IN PLACE.</p>
	<p>Step 5: SLIDE FERRULE "A" TOWARDS THE CONNECTOR AND CRIMP.</p>

This part number complies with RoHS.

Notice: JYEBAO reserves the right to make modifications deemed appropriate.