

Feature

- Double-data rate architecture; two data transfer per clock cycle
- Bidirectional, data strobe (DQS, \overline{DQS}) is transmitted/received with data, to be used in capturing data at the receiver
- Differential clock inputs (CK and \overline{CK})
- Differential data strobe (DQS and \overline{DQS})
- Commands & addresses entered on both positive & negative CK edge; data and data mask referenced to both edges of DQS
- Eight internal banks for concurrent operation
- Data mask (DM) for write data
- Programmable Burst Lengths: 4 ,8 or 16
- Burst type: Sequential or interleave
- Programmable RL (Read latency) & WL (Write latency)
- Clock Stop capability during idle period
- Auto Pre-charge for each burst access
- Configurable Drive Strength (DS)
- Auto Refresh and Self Refresh Modes
- Optional Partial Array Self Refresh (PASR) and Temperature Compensated Self Refresh (TCSR)
- Deep Power Down Mode (DPD)
- HSUL_12 compatible inputs (High Speed Undermanaged Logic 1.2V)
- VDD2/VDDCA/VDDQ= 1.14~1.3V; VDD1= 1.70~1.95V
- Configuration and Addressing

Items		512Mb
Device Type		S4
Number of Banks		8
Bank Addresses		BA0-BA1
X16	Row	R0-R12
	Column	C0-C9
x32	Row	R0-R12
	Column	C0-C8

Options

VDD1/VDD2/VDDQ/VDDCA

-1.8V/1.2V/1.2V/1.2V (S4B)

Configuration

-16M x 32

- 32M x 16

RoHS compliance and Halogen free

Package

-168-Ball PoP 12mm x 12mm 0.5mm pitch

Timing – cycle time

-2.5ns @ RL=6 (400MHz – DDR800)

-3.0ns @ RL=5 (333MHz – DDR667)

Operating temperature range

-Commercial (-25°C to +85°C)

-Industrial (-40°C to +85°C)

Description

LPDDR2-S4 uses the double data rate architecture on the Command/Address (CA) bus to reduce the number of input pins in the system. The 10-bit CA bus contains command, address, and Bank/Row Buffer information. Each command uses one clock cycle, during which command information is transferred on both the positive and negative edge of the clock.

To achieve high-speed operation, our LPDDR2-S4 SDRAM uses the double data rate architecture and adopt 4n-prefetch interface designed to transfer two data per clock cycle at the I/O pins. A single read or write access for the LPDDR2-S4 effectively consists of a single 4n-bit wide, one clock cycle data transfer at the internal SDRAM core and four corresponding n-bit wide, one-half-clock-cycle data transfer at the I/O pins. Read and write accesses to the LPDDR2-S4 are burst oriented; accesses start at a selected location and continue for a programmed number of locations in a programmed sequence.

For LPDDR2-S4 devices, accesses begin with the registration of an Active command, which is then followed by a Read or Write command. The address and BA bits registered coincident with the Active command are used to select the row and the Bank to be accessed. The address bits registered coincident with the Read or Write command are used to select the Bank and the starting column location for the burst access.

Ordering Information

Density	Organization	Part Number	Package	Speed			
				t _{CK} (ns)	Clock (MHz)	Data Rate (Mb/s/pin)	RL
512Mb	16M x 32	NT6TL16M32AQ-G1	168-Ball PoP 12mm x 12mm 0.5mm pitch	2.5	400	800	6
		NT6TL16M32AQ-G2		3.0	333	667	5
	32M x 16	NT6TL32M16AQ-G1		2.5	400	800	6
		NT6TL32M16AQ-G2		3.0	333	667	5

NANYA Mobile Component/Wafer Part Numbering Guide:

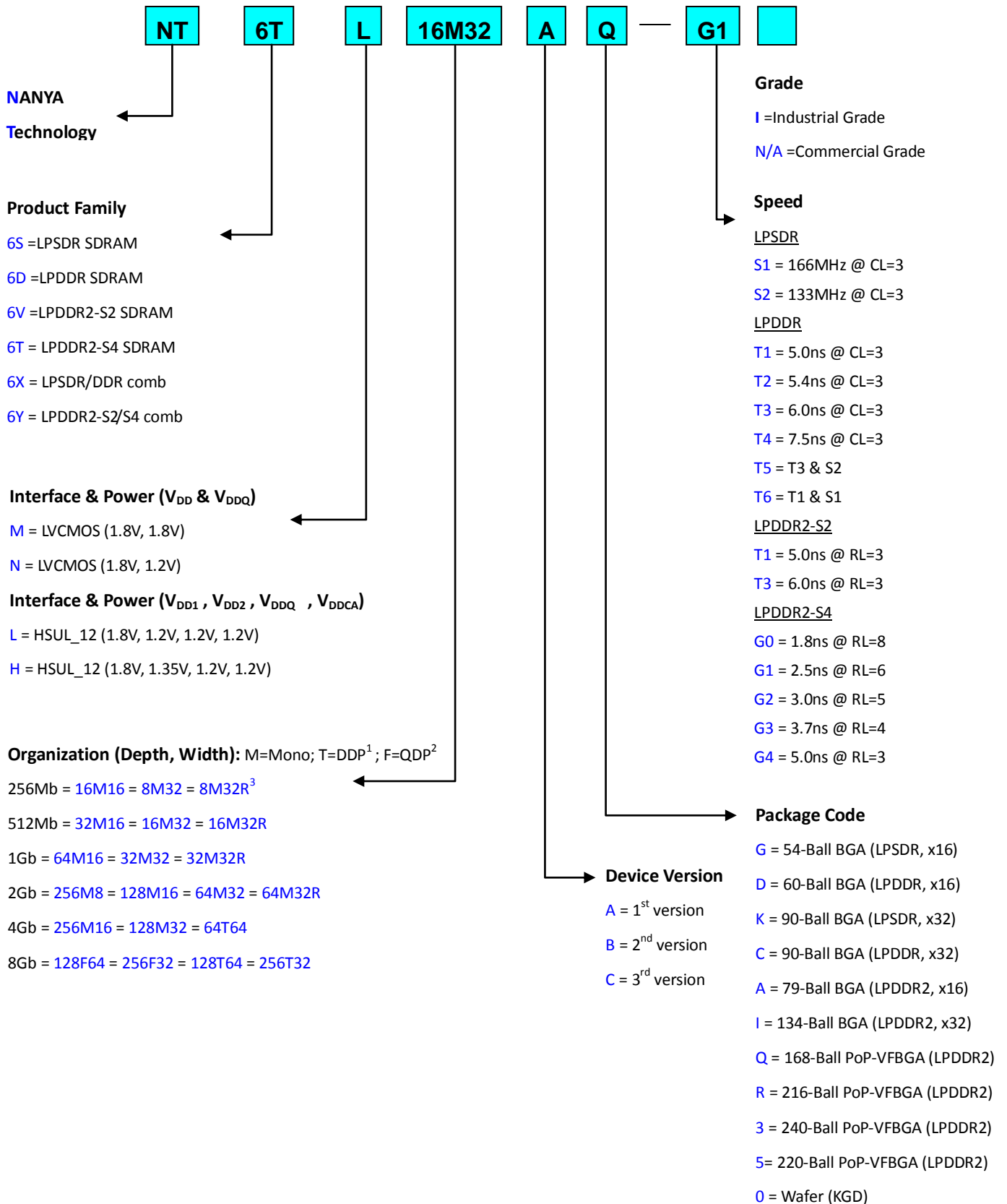

Block Diagram – Single Die, Single Channel Package

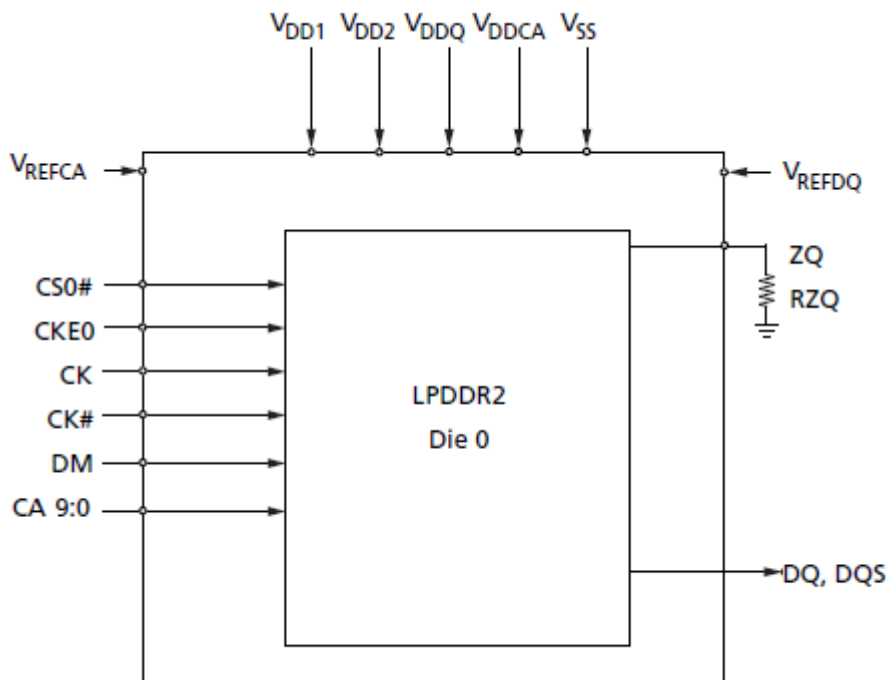

Pin Configuration – 168 balls PoP-VFBGA Package

< TOP View >

See the balls through the package

	1	2	3	4	5	6	7	8	9	10	11	12	13	14	15	16	17	18	19	20	21	22	23	
A	DNU	DNU	N/C	N/C	N/C	N/C	N/C	N/C	N/C	N/C	VDD1	VSSQ	DQ30	DQ29	VSSQ	DQ26	DQ25	VSSQ	DQS3_c	VDD1	VSS	DNU	DNU	A
B	DNU	DNU	VDD1	N/C	N/C	N/C	N/C	N/C	N/C	VSS	VDD2	DQ31	VDDQ	DQ28	DQ27	VDDQ	DQ24	DQS3_t	VDDQ	DM3	VDD2	DNU	DNU	B
C	VSS	VDD2																				DQ15	VSSQ	C
D	N/C	N/C																				VDDQ	DQ14	D
E	N/C	N/C																				DQ12	DQ13	E
F	N/C	N/C																				DQ11	VSSQ	F
G	N/C	N/C																				VDDQ	DQ10	G
H	N/C	N/C																				DQ8	DQ9	H
J	N/C	N/C																				DQS1_t	VSSQ	J
K	N/C	N/C																				VDDQ	DQS1_c	K
L	N/C	N/C																				VDD2	DM1	L
M	N/C	VSS																				Vref(DQ)	VSS	M
N	N/C	VDD1																				VDD1	DM0	N
P	ZQ0	Vref(CA)																				DQS0_c	VSSQ	P
R	VSS	VDD2																				VDDQ	DQS0_t	R
T	CA9	CA8																				DQ6	DQ7	T
U	CA7	VDDCA																				DQ5	VSSQ	U
V	VSSCA	CA6																				VDDQ	DQ4	V
W	CA5	VDDCA																				DQ2	DQ3	W
Y	CK_c	CK_t																				DQ1	VSSQ	Y
AA	VSS	VDD2																				VDDQ	DQ0	AA
AB	DNU	DNU	CS0_n	CS1_n	VDD1	CA1	VSSCA	CA3	CA4	VDD2	VSS	DQ16	VDDQ	DQ18	DQ20	VDDQ	DQ22	DQS2_t	VDDQ	DM2	VDD2	DNU	DNU	AB
AC	DNU	DNU	CKE0	CKE1	VSS	CA0	CA2	VDDCA	N/C	N/C	ZQ1	VSSQ	DQ17	DQ19	VSSQ	DQ21	DQ23	VSSQ	DQS2_c	VDD1	VSS	DNU	DNU	AC

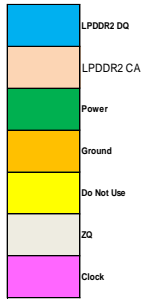

- Note: 1. 12x12 mm, 0.5mm pitch
- 2. 168 Ball Count
- 3. Top View, A1 in Top Left Corner

Package Dimensions (168 balls; 12mm x 12mm)

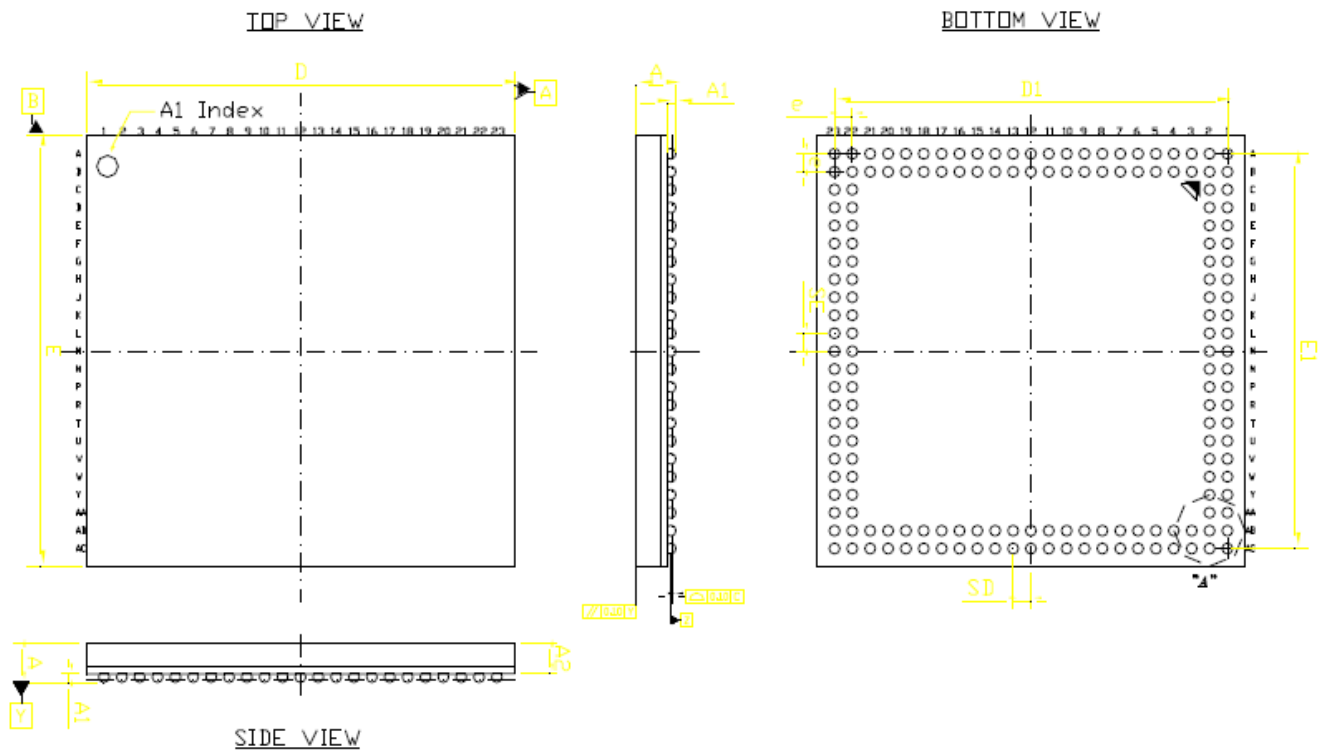

REF.	Dimension in mm		
	Min	Nom	Max
A	—	—	0.790
A1	0.250	0.275	0.315
A2	0.410	—	0.470
∅b	0.30	0.33	0.36
D	11.90	12.00	12.10
D1	11.00 BSC		
E	119.0	12.00	12.10
E1	11.00 BSC		
SE	0.50 BSC		
SD	0.50 BSC		
e	0.50 BSC		

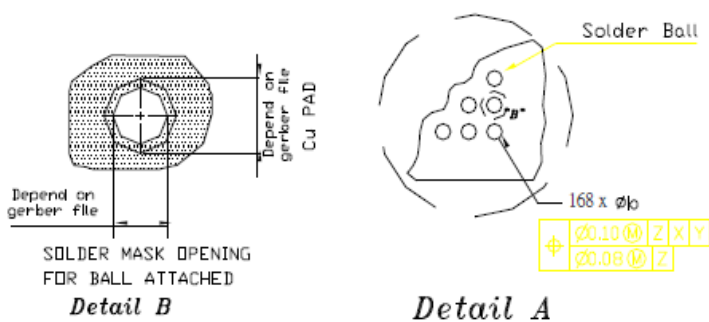

Input / Output Functional Description

Symbol	Type	Function
CK, \overline{CK}	Input	Clock: CK and \overline{CK} are differential clock inputs. All Double Data Rate (DDR) CA input signals are sampled on both positive and negative edge of CK. CS_n and CKE inputs are sampled at the positive edge of CK. AC timings are referenced to clock.
CKE	Input	Clock Enable: CKE high activates, and CKE low deactivates internal clock signals, and device input buffers and output drivers. Power saving modes are entered and exited through CKE transitions. CKE is considered part of the command code. CKE is sampled at the positive Clock edge.
CS_n	Input	Chip Select: CS_n is considered part of the command code. CS_n is sampled at the positive Clock edge.
CA0 – CA9	Input	Command/Address Inputs: Uni-directional command/address bus inputs. Provide the command and address inputs according to the command truth table. CA is considered part of the command code.
DM0-DM3	Input	Input Data Mask: DM is an input mask signal for write data. Input data is masked when DM is sampled HIGH coincident with that input data during a Write access. DM is sampled on both edges of DQS. Although DM pins are input-only, the DM loading matched the DQ and DQS (or \overline{DQS}). DM0 corresponds to the data on DQ0-DQ7, DM1 corresponds to the data on DQ8-DQ15, DM2 corresponds to the data on DQ16-DQ23, and DM3 corresponds to the data on DQ24-DQ31.
DQ0-DQ31	Input/output	Data Bus: Bi-directional Input / Output data bus.
DQS, \overline{DQS} DQS0-3, $\overline{DQS0-3}$	Input/output	Data Strobe (Bi-directional, Differential): The data strobe is bi-directional (used for read and write data) and Differential (DQS and \overline{DQS}). It is output with read data and input with write data. DQS is edge-aligned to read data, and centered with write data. DQS0 & $\overline{DQS0}$ corresponds to the data on DQ0-DQ7, DQS1 & $\overline{DQS1}$ corresponds to the data on DQ8-DQ15, DQS2 & $\overline{DQS2}$ corresponds to the data on DQ16-DQ23, DQS3 & $\overline{DQS3}$ corresponds to the data on DQ24-DQ31.
NC	-	No Connect: No internal electrical connection is present.
ZQ	Input	Reference Pin for Output Drive Strength Calibration. External impedance (240-ohm): this signal is used to calibrate the device output impedance.
VDDQ	Supply	DQ Power Supply: Isolated on the die for improved noise immunity.
VSSQ	Supply	DQ Ground: Isolated on the die for improved noise immunity.
VDDCA	Supply	Command / Address Power Supply.
VSSCA	Supply	Command / Address Ground: Isolated on the die for improved noise immunity.
VREFDQ, VREFCA	Supply	Reference Voltage: VREFDQ is reference for DQ input buffers. VREFCA is reference for Command / Address input buffers.

512Mb LPDDR2-S4 SDRAM

NT6TL16M32AQ/ NT6TL32M16AQ



Symbol	Type	Function
V _{DD1}	Supply	Core power supply 1.
V _{DD2}	Supply	Core power supply2.
V _{SS}	Supply	Common Ground.

Notes: Data includes DQ and DM.

Simplified State Diagram

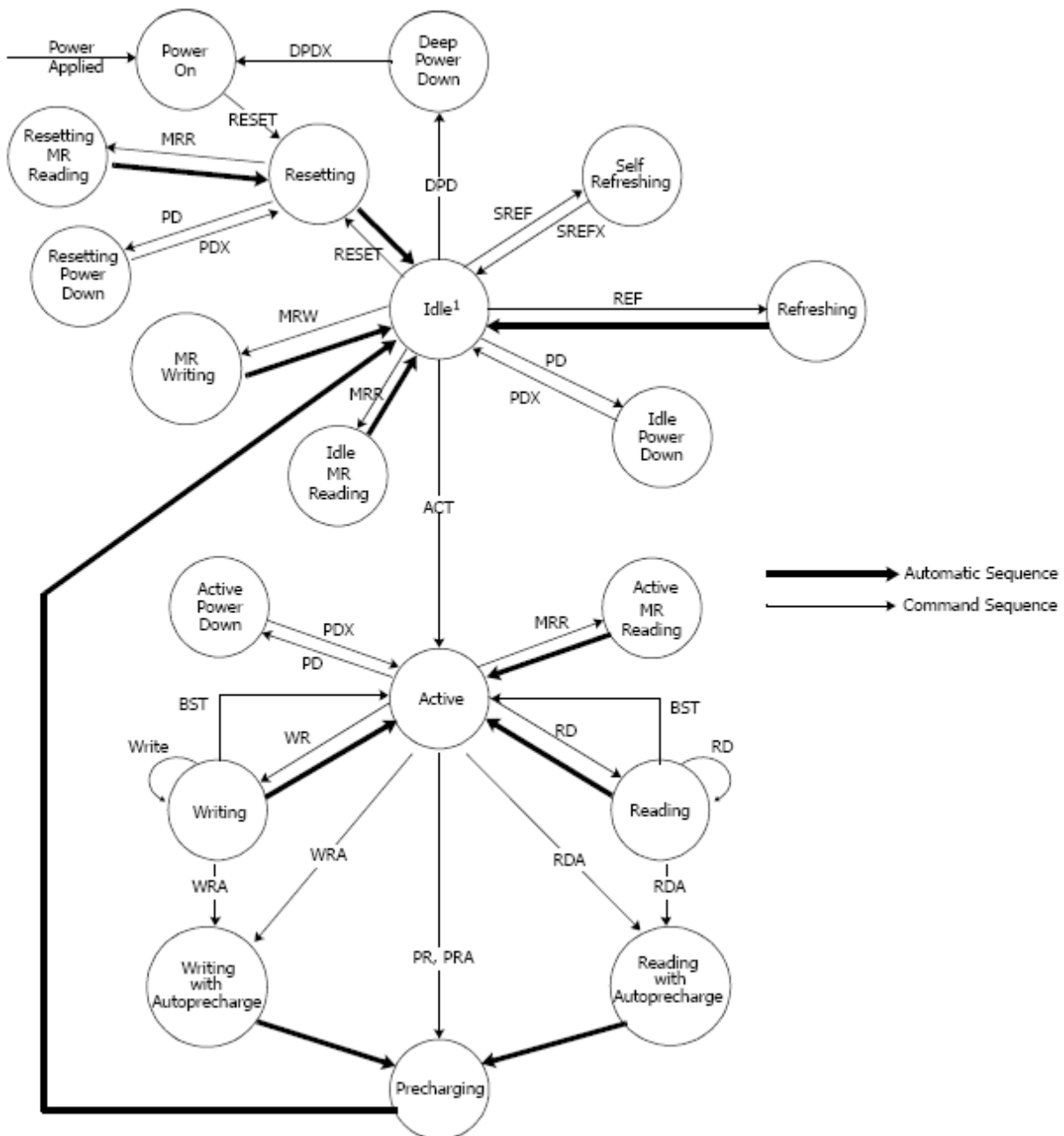

Abbreviation	Function	Abbreviation	Function	Abbreviation	Function
ACT	Active	PD	Enter Power Down	REF	Refresh
RD(A)	Read (w/ Autoprecharge)	PDX	Exit Power Down	SREF	Enter self refresh
WR(A)	Write (w/ Autoprecharge)	DPD	Enter Deep Power Down	SREFX	Exit self refresh
PR(A)	Precharge (All)	DPDX	Exit Deep Power Down		
MRW	Mode Register Write	BST	Burst Terminate		
MRR	Mode Register Read	RESET	Reset is achieved through MRW command		

Notes: 1. For LPDDR2-S4 SDRAM in the idle state, all banks are precharged.

Absolute Maximum Ratings

Symbol	Parameter	Min	Max	Units
V _{DD1}	Voltage on V _{DD1} pin relative to V _{ss}	-0.4	2.3	V
V _{DD2}	Voltage on V _{DD2} pin relative to V _{ss}	-0.4	1.6	V
V _{DCCA}	Voltage on V _{DCCA} pin relative to V _{ss}	-0.4	1.6	V
V _{DDQ}	Voltage on V _{DDQ} pin relative to V _{ss}	-0.4	1.6	V
V _{in} , V _{out}	Voltage on any pin relative to V _{ss}	-0.4	1.6	V
T _{stg}	Storage Temperature (plastic)	-55	+125	°C

Notes:

1. Stresses greater than those listed under "Absolute Maximum Ratings" may cause permanent damage to the device. This is a stress rating only and functional operation of the device at these or any other conditions above those indicated in the operational sections of this specification is not implied. Exposure to absolute maximum rating conditions for extended periods may affect reliability.
2. Storage Temperature is the case surface temperature on the center/top side of the DRAM. For measurement conditions, refer to the JESD51-2 standard.
3. V_{DD2} and V_{DDQ} / V_{DCCA} must be within 200mV of each other at all times.
4. Voltage on any I/O may not exceed voltage on V_{DDQ}; Voltage on any CA input may not exceed voltage on V_{DCCA}.
5. V_{REF} must always be less than all other supply voltages.
6. The voltage difference between any V_{SS}, V_{SSQ}, or V_{SSCA} pins may not exceed 100mV.

AC/DC Operating Conditions

DC Operating Conditions

Symbol	Parameter	Min	Norm	Max	Unit	Notes
Power Supply						
V _{DD1}	Core Supply voltage 1	1.70	1.80	1.95	V	
V _{DD2}	Core Supply voltage 2	1.14	1.20	1.30	V	
V _{DDCA}	Input Supply Voltage (Command / Address)	1.14	1.20	1.30	V	
V _{DDQ}	I/O Supply voltage (DQ)	1.14	1.20	1.30	V	
Leakage current						
I _I	Input leakage current Any input $0 \leq V_{IN} \leq V_{DDQ} / V_{DDCA}$, All other pins not under test = 0V	-2	-	2	uA	1
I _{VREF}	V _{REF} leakage current; V _{REFDQ} = V _{DDQ} /2 or V _{REFCA} = V _{DDCA} /2 (all other pins not under test = 0V)	-1	-	1	uA	1

Notes:

- The minimum limit requirement is for testing purposes. The leakage current on VREFCA and VREFDQ pins should be minimal. Although DM is for input only, the DM leakage shall match the DQ and DQS_t, \overline{DQS}_c output leakage specification.

Temperature Range

Symbol	Parameter / Condition	Min	Norm	Max	Unit	Notes
T _{CASE}	Commercial	-25	-	+85	°C	
T _{CASE}	Industrial (IT)	-40	-	+85	°C	

Notes:

- Operating temperature is the case surface temperature at the center of the top side of the device. For measurement conditions, refer to the JESD51-2 standard.
- Either the device case temperature rating or the temperature sensor (See "Temperature Sensor" on page 117) may be used to set an appropriate refresh rate, determine the need for AC timing de-rating and/or monitor the operating temperature (SDRAM and NVM). When using the temperature sensor, the actual device case temperature may be higher than the T_{OPER} rating that applies for the Standard or Extended Temperature Ranges. For example, T_{CASE} may be above 85°C when the temperature sensor indicates a temperature of less than 85 °C.

AC/DC Input Measurement Level

AC and DC Logic Levels for Single-Ended Signals

CA inputs (Address and Command) and \overline{CS} inputs							
Symbol	Parameter	LPDDR2 1066-466		LPDDR2 400-200		Unit	Notes
		Min	Max	Min	Max		
$V_{IHCA(AC)}$	AC Input logic HIGH voltage	$V_{REFCA} + 220mV$	-	$V_{REFCA} + 300mV$	-	mV	
$V_{IHCA(DC)}$	DC Input logic HIGH voltage	$V_{REFCA} + 130mV$	V_{DDCA}	$V_{REFCA} + 200mV$	V_{DDCA}	mV	
$V_{ILCA(AC)}$	AC Input logic LOW voltage	-	$V_{REFCA} - 220mV$	-	$V_{REFCA} - 300mV$	mV	
$V_{ILCA(DC)}$	DC Input logic LOW voltage	V_{SSCA}	$V_{REFCA} - 130mV$	V_{SSCA}	$V_{REFCA} - 200mV$	mV	
$V_{REFCA(DC)}$	Reference voltage for CA and \overline{CS} inputs	$0.49 \times V_{DDCA}$	$0.51 \times V_{DDCA}$	$0.49 \times V_{DDCA}$	$0.51 \times V_{DDCA}$	V	
Data inputs (DQ & DM)							
$V_{IHDQ(AC)}$	AC Input logic HIGH voltage	$V_{REFDQ} + 220mV$	-	$V_{REFDQ} + 300mV$	-	mV	
$V_{IHDQ(DC)}$	DC Input logic HIGH voltage	$V_{REFDQ} + 130mV$	V_{DDQ}	$V_{REFDQ} + 200mV$	V_{DDQ}	mV	
$V_{ILDQ(AC)}$	AC Input logic LOW voltage	-	$V_{REFDQ} - 220mV$	-	$V_{REFDQ} - 300mV$	mV	
$V_{ILDQ(DC)}$	DC Input logic LOW voltage	V_{SSQ}	$V_{REFDQ} - 130mV$	V_{SSQ}	$V_{REFDQ} - 200mV$	mV	
$V_{REFDQ(DC)}$	Reference voltage for DQ and DM inputs	$0.49 \times V_{DDQ}$	$0.51 \times V_{DDQ}$	$0.49 \times V_{DDQ}$	$0.51 \times V_{DDQ}$	V	
Clock enable inputs (CKE)							
Symbol	Parameter	Min		Max		Unit	Notes
$V_{IHCKE(AC)}$	CKE AC Input HIGH voltage	$0.8 * V_{DDCA}$		-		V	
$V_{ILCKE(AC)}$	CKE AC Input LOW voltage	-		$0.2 * V_{DDCA}$		V	

Notes:

2. V_{DD2} and V_{DDQ}/V_{DDCA} must be within 200mV of each other all the times.
3. For VREF deviation tolerance, refer to “VREF Tolerance” on page 14.
4. V_{DD} and V_{DDQ} must track each other and V_{DDQ} must be less than or equal to V_{DD} .
5. All voltages referenced to V_{SS} .
6. All parameters assume proper device initialization.
7. Tests for AC timing, I_{DD} , and electrical AC and DC characteristics may be conducted at nominal supply voltage levels, but the related specifications and device operation are guaranteed for the full voltage and temperature range specified.
8. The typical value of $V_{OX(AC)}$ is expected to be about $0.5 \times V_{DDQ}$ of the transmitting device and $V_{OX(AC)}$ is expected to track variations in V_{DDQ} . $V_{OX(AC)}$ indicates the voltage at which differential output signals must cross.
9. The minimum limit requirement is for testing purposes. The leakage current on VREFCA and VREFDQ pins should be minimal. Although DM is for input only, the DM leakage shall match the DQ and $DQS_{t, \overline{DQS}_c}$ output leakage specification.

V_{REF} Tolerance

The DC tolerance limits and AC noise limits for the reference voltages V_{REFCA} and V_{REFDQ} are illustrated below. This figure shows a valid reference voltage V_{REF}(t) as a function of time. V_{DD} is used in place of V_{DDCA} for V_{REFCA}, and V_{DDQ} for V_{REFDQ}. V_{REF(DC)} is the linear average of V_{REF}(t) over a very long period of time (e.g., 1 second) and is specified as a fraction of the linear average of V_{DDQ} or V_{DDCA}, also over a very long period of time (e.g., 1 second). This average must meet the MIN/MAX requirements. Additionally, V_{REF}(t) can temporarily deviate from V_{REF(DC)} by no more than ±1% V_{DD}. V_{REF}(t) cannot track noise on V_{DDQ} or V_{DDCA} if doing so would force V_{REF} outside these specifications.

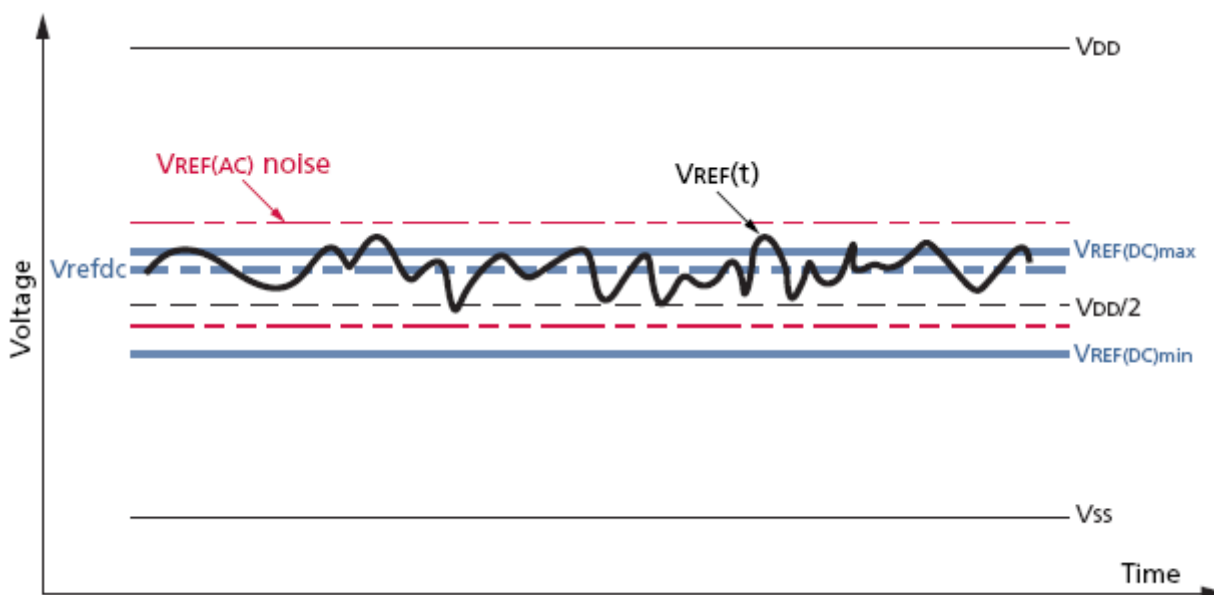

V_{REF} DC Tolerance and V_{REF} AC Noise Limits

The voltage levels for setup and hold time measurements V_{IH(AC)}, V_{IH(DC)}, V_{IL(AC)}, and V_{IL(DC)} are dependent on V_{REF}. V_{REF} DC variations affect the absolute voltage a signal must reach to achieve a valid HIGH or LOW, as well as the time from which setup and hold times are measured. When V_{REF} is outside the specified levels, devices will function correctly with appropriate timing deratings as long as:

- V_{REF} is maintained between 0.44 x V_{DDQ} (or V_{DDCA}) and 0.56 x V_{DDQ} (or V_{DDCA}), and the controller achieves the required single-ended AC and DC input levels from instantaneous V_{REF}.

System timing and voltage budgets must account for V_{REF} deviations outside this range.

The setup/hold specification and derating values must include time and voltage associated with V_{REF} AC noise. Timing and voltage effects due to AC noise on V_{REF} up to the specified limit (±1% V_{DD}) are included in LPDDR2 timings and their associated deratings.

Input Signal

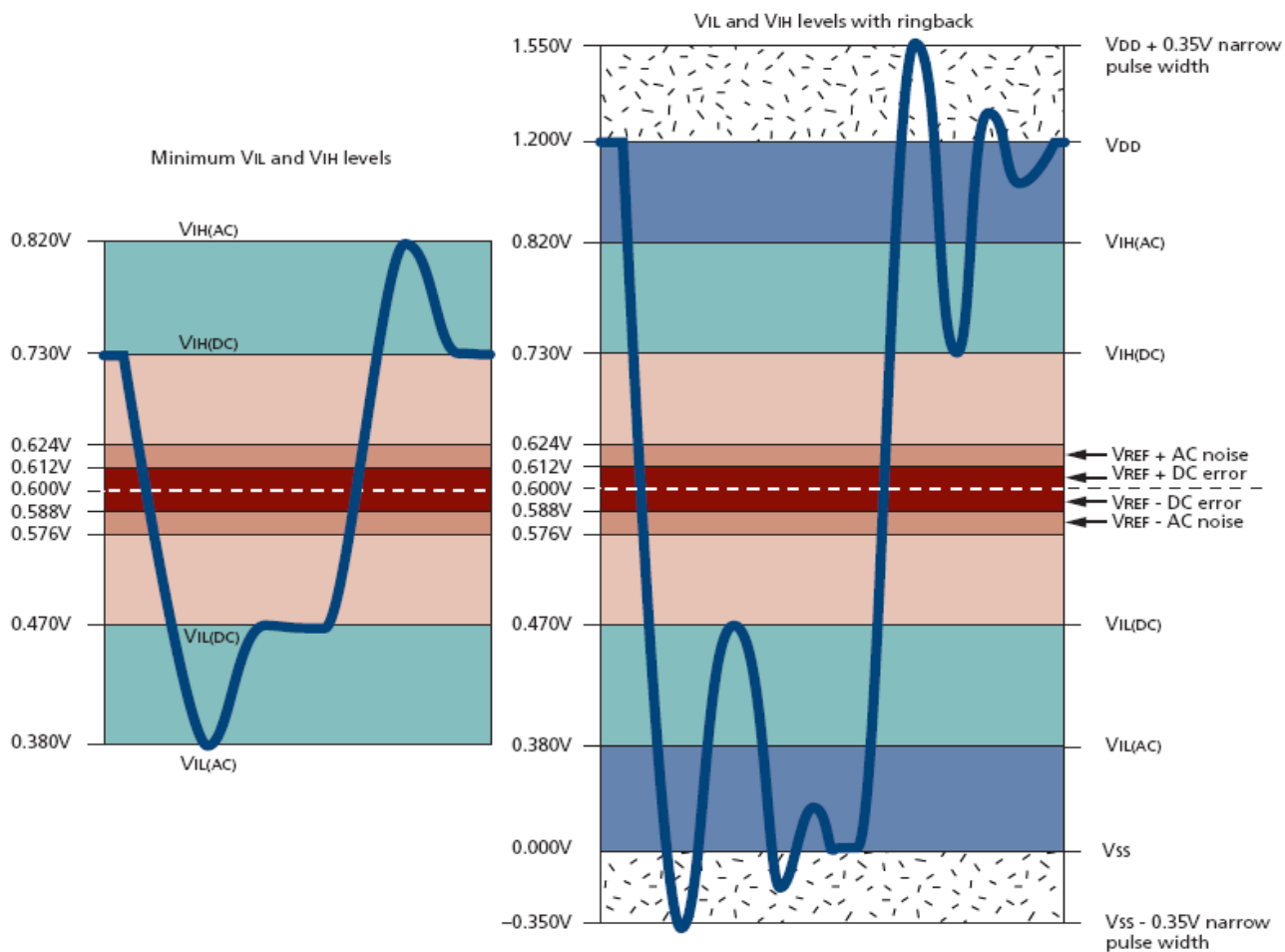

LPDDR2 466-1066 Input Signal

Notes:

1. Numbers reflect typical values.
2. For CA[9:0], CK, \overline{CK} , \overline{CS} , and CKE, VDD stands for VDDCA. For DQ, DM, DQS, and \overline{DQS} , VDD stands for VDDQ.
3. For CA[9:0], CK, \overline{CK} , \overline{CS} , and CKE, VSS stands for VSSCA. For DQ, DM, DQS, and \overline{DQS} , VSS stands for VSSQ.

AC and DC Logic Levels for Differential Signals

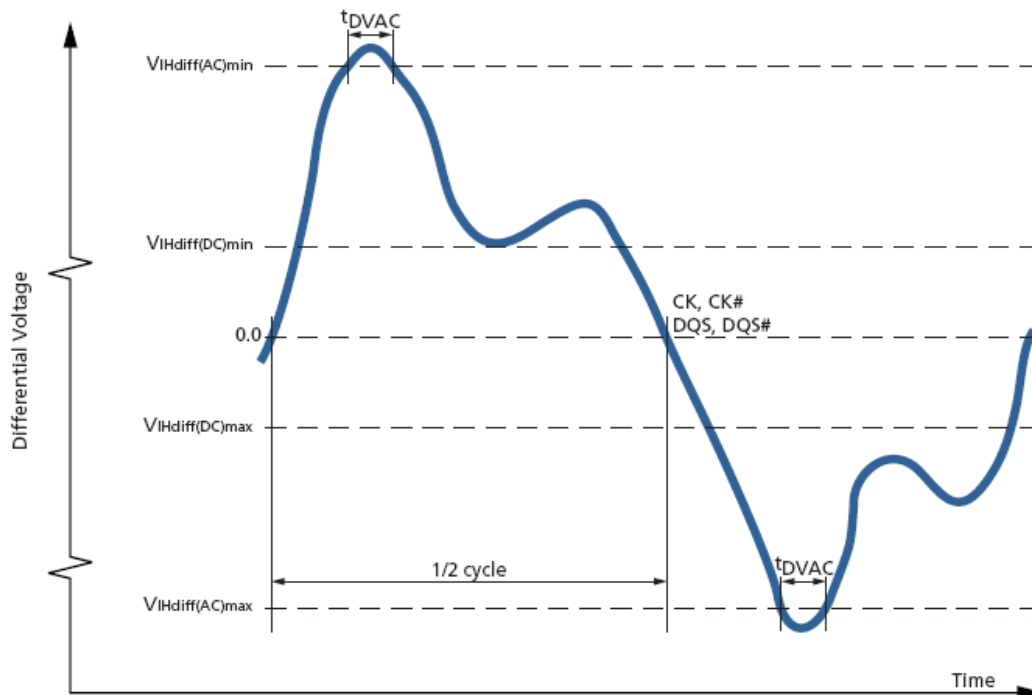

Differential AC and DC Input Levels

Differential Inputs logical levels (CK, \overline{CK} - $V_{REF} = V_{REFCA(DC)}$; DQS, \overline{DQS} : $V_{REF} = V_{REFDQ(DC)}$)							
Symbol	Parameter	LPDDR2 1066-466		LPDDR2 400-200		Unit	Notes
		Min	Max	Min	Max		
$V_{IHdiff(AC)}$	Differential input voltage HIGH AC	2 x $(V_{IH(AC)} - V_{REF})$	Note 3	2 x $(V_{IH(AC)} - V_{REF})$	Note 3	V	
$V_{ILdiff(AC)}$	Differential input voltage LOW AC	Note 3	2 x $(V_{REF} - V_{IL(AC)})$	Note 3	2 x $(V_{REF} - V_{IL(AC)})$	V	
$V_{IHdiff(DC)}$	Differential input voltage HIGH DC	2 x $(V_{IH(DC)} - V_{REF})$	Note 3	2 x $(V_{IH(DC)} - V_{REF})$	Note 3	V	
$V_{ILdiff(DC)}$	Differential input voltage LOW DC	Note 3	2 x $(V_{REF} - V_{IL(DC)})$	Note 3	2 x $(V_{REF} - V_{IL(DC)})$	V	

Notes:

- Used to define a differential signal slew-rate. For CK_t - CK_c use $V_{IH}/V_{IL}(dc)$ of CA and V_{REFCA} ; for DQS_t - DQS_c, use $V_{IH}/V_{IL}(dc)$ of DQs and V_{REFDQ} ; if a reduced dc-high or dc-low level is used for a signal group, then the reduced level applies also here.
- For CK and \overline{CK} , use $V_{IH}/V_{IL}(AC)$ of CA and V_{REFCA} ; for DQS and \overline{DQS} , use $V_{IH}/V_{IL}(AC)$ of DQ and V_{REFDQ} . If a reduced AC HIGH or AC LOW is used for a signal group, the reduced voltage level also applies.
- These values are not defined, however the single-ended signals CK, \overline{CK} , DQS, and \overline{DQS} must be within the respective limits ($V_{IH(DC)max}$, $V_{IL(DC)min}$) for single-ended signals and must comply with the specified limitations for overshoot and undershoot.

CK, \overline{CK} and DQS, \overline{DQS} Time Requirement before Ring back (t_{DVAC})

Slew Rate (V/ns)	t_{DVAC} (ps) at $V_{IH}/V_{ILdiff(AC)} = 440mV$	t_{DVAC} (ps) at $V_{IH}/V_{ILdiff(AC)} = 600mV$
	Min	Max
>4.0	175	75
4.0	170	57
3.0	167	50
2.0	163	38
1.8	162	34
1.6	161	29
1.4	159	22
1.2	155	13
1.0	150	0
<1.0	150	0

Single-Ended Requirements for Differential Signals

Each individual component of a differential signal (CK, \overline{CK} , DQS, and \overline{DQS}) must also comply with certain requirements for single-ended signals. CK and \overline{CK} must meet $V_{SEH(AC)min}/V_{SEL(AC)max}$ in every half cycle. DQS, \overline{DQS} must meet $V_{SEH(AC)min}/V_{SEL(AC)max}$ in every half cycle preceding and following a valid transition.

The applicable AC levels for CA and DQ differ by speed-bin.

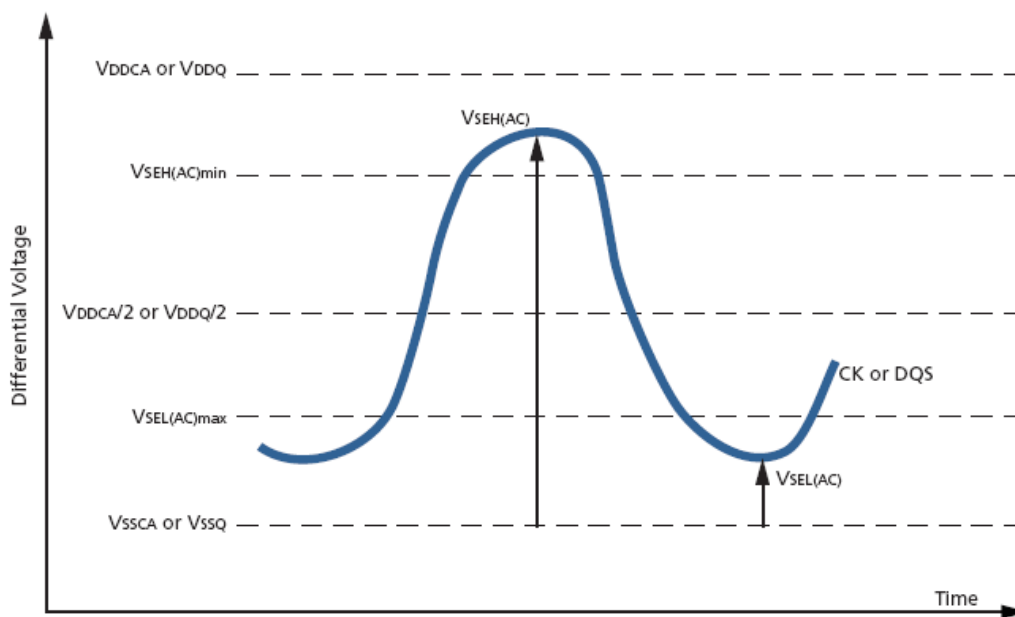

Single-Ended Requirement for Differential Signals

Note that while CA and DQ signal requirements are referenced to VREF, the single-ended components of differential signals also have a

requirement with respect to $V_{DDQ}/2$ for DQS, and $V_{DDCA}/2$ for CK. The transition of single-ended signals through the AC levels is used to measure setup time. For single-ended components of differential signals, the requirement to reach $V_{SEL(AC)max}$ or $V_{SEL(AC)min}$ has no bearing on timing; this requirement does, however, add a restriction on the common mode characteristics of these signals.

Single-Ended Levels for CK, \overline{CK} , DQS, \overline{DQS}

Symbol	Parameter	LPDDR2 1066-466		LPDDR2 400-200		Unit	Notes
		Min	Max	Min	Max		
$V_{SEH(AC)}$	Single-ended HIGH level for strobes	$(V_{DDQ}/2)+0.22$	Note 3	$(V_{DDQ}/2)+0.30$	Note 3	V	
	Single-ended HIGH level for CK, \overline{CK}	$(V_{DDCA}/2)+0.22$	Note 3	$(V_{DDCA}/2)+0.30$	Note 3	V	
$V_{SEL(AC)}$	Single-ended LOW level for strobes	Note 3	$(V_{DDQ}/2)-0.22$	Note 3	$(V_{DDQ}/2)+0.30$	V	
	Single-ended LOW level for CK, \overline{CK}	Note 3	$(V_{DDCA}/2)-0.22$	Note 3	$(V_{DDCA}/2)+0.30$	V	

Notes:

1. For CK and \overline{CK} , use $V_{SEH}/V_{SEL(AC)}$ of CA; for strobes (DQS[3:0] and \overline{DQS} [3:0]) use $V_{IH}/V_{IL(AC)}$ of DQ.
2. $V_{IH(AC)}$ and $V_{IL(AC)}$ for DQ are based on V_{REFDQ} ; $V_{SEH(AC)}$ and $V_{SEL(AC)}$ for CA are based on V_{REFCA} . If a reduced AC HIGH or AC LOW is used for a signal group, the reduced level applies.
3. These values are not defined, however the single-ended signals CK, \overline{CK} , DQS0, $\overline{DQS0}$, DQS1, $\overline{DQS1}$, DQS2, $\overline{DQS2}$, DQS3, $\overline{DQS3}$ must be within the respective limits ($V_{IH(DC)max}$, $V_{IL(DC)min}$) for single-ended signals, and must comply with the specified limitations for overshoot and undershoot.

Differential input Cross-Point Voltage

To ensure tight setup and hold times as well as output skew parameters with respect to clock and strobe, each cross-point voltage of differential input signals (CK, \overline{CK} , DQS, and \overline{DQS}) must meet the specifications below. The differential input cross-point voltage (V_{ix}) is measured from the actual cross point of true and complement signals to the midlevel between VDD and Vss .

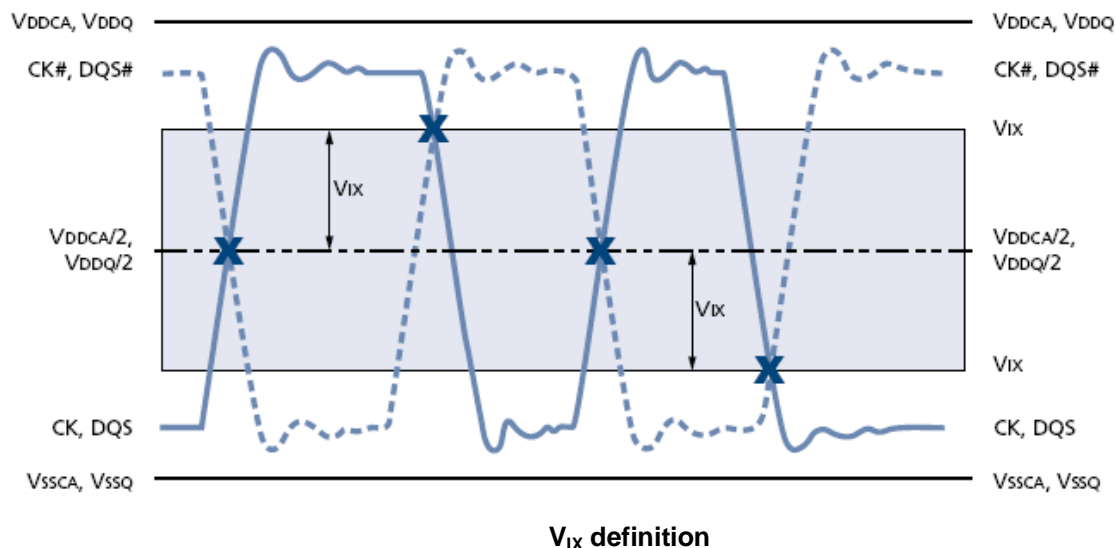

Cross-Point Voltage for Differential Input Signals (CK, \overline{CK} , DQS, \overline{DQS})

Symbol	Parameter	LPDDR2 200-1066		Unit	Notes
		Min	Max		
$V_{IXCA(AC)}$	Differential input cross-point voltage relative to $V_{DDCA}/2$ for CK and \overline{CK}	-120	+120	mV	
$V_{IXDQ(AC)}$	Differential input cross-point voltage relative to $V_{DDQ}/2$ for DQS and \overline{DQS}	-120	+120	mV	

Notes:

1. The typical value of $V_{IX(AC)}$ is expected to be about $0.5 \times V_{DD}$ of the transmitting device, and it is expected to track variations in V_{DD} . $V_{IX(AC)}$ indicates the voltage at which differential input signals must cross.
2. For CK and \overline{CK} , $V_{REF} = V_{REFCA(DC)}$. For DQS and \overline{DQS} , $V_{REF} = V_{REFDQ(DC)}$.

Slew Rate Definitions for Single-Ended Input Signals

Refer to page 51, 57 for single-ended slew rate definition for address, command and data signals respectively.

Slew Rate Definitions for Differential Input Signals

Description	Defined by	Measured	
		From	To
Differential input slew rate for rising edge (CK, \overline{CK} and DQS, \overline{DQS})	$[V_{IHdiffmin} - V_{Ldiffmax}] / \Delta TR_{diff}$	$V_{Ldiffmax}$	$V_{IHdiffmin}$
Differential input slew rate for falling edge (CK, \overline{CK} and DQS, \overline{DQS}).	$[V_{IHdiffmin} - V_{Ldiffmax}] / \Delta TF_{diff}$	$V_{IHdiffmin}$	$V_{Ldiffmax}$

Notes:

The differential signals (CK, \overline{CK} and DQS, \overline{DQS}) must be linear between these thresholds.

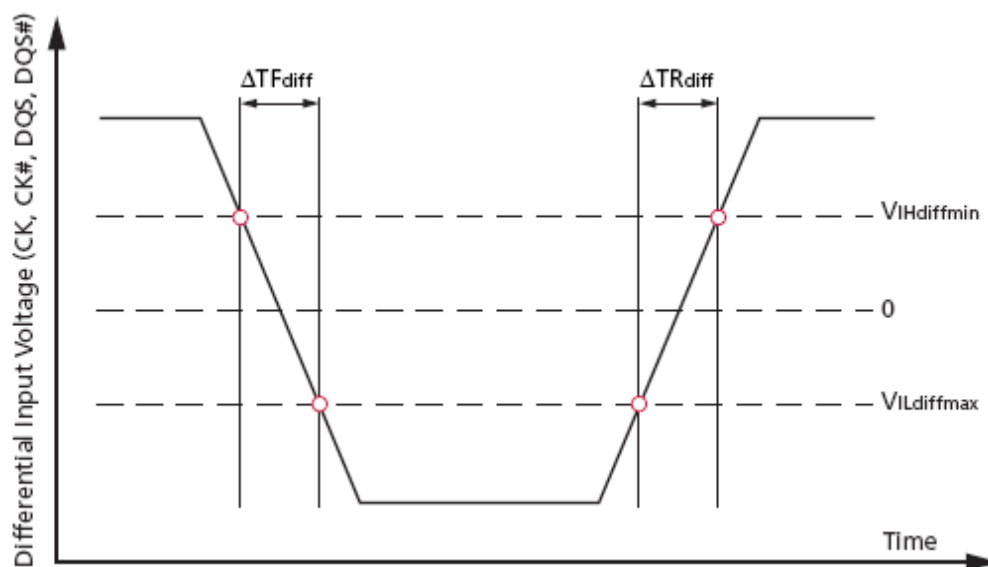

Differential Input Slew Rate Definition for CK, \overline{CK} , DQS and \overline{DQS}

AC/DC Output Measurement Level

Single-Ended AC and DC Output Levels

Symbol	Parameter	LPDDR2 200-1066	Unit	Notes
$V_{OH(AC)}$	AC output HIGH measurement level (for output slew rate)	$V_{REF} + 0.12$	V	
$V_{OL(AC)}$	AC output LOW measurement level (for output slew rate)	$V_{REF} - 0.12$	V	
$V_{OH(DC)}$	DC output HIGH measurement level (for I-V curve linearity)	$0.9 \times V_{DDQ}$	V	
$V_{OL(DC)}$	DC output LOW measurement level (for I-V curve linearity)	$0.1 \times V_{DDQ}$	V	
I _{OZ}	Output leakage current (DQ, DM, DQS, \overline{DQS}) (DQ, DQS, \overline{DQS} are disabled; $0V \leq V_{OUT} \leq V_{DDQ}$)	Min	-5	uA
		Max	5	uA
MMpupd	Delta output impedance between pull-up and pull-down for DQ/DM	Min	-15	%
		Max	15	%

Notes:

1. I_{OH} = -0.1mA.
2. I_{OL} = 0.1mA.

Differential AC and DC Output Levels

Symbol	Parameter	LPDDR2 200-1066	Unit	Notes
$V_{OHdiff(AC)}$	AC differential output HIGH measurement level (for output slew rate)	$+ 0.20 \times V_{DDQ}$	V	
$V_{OLdiff(AC)}$	AC differential output LOW measurement level (for output slew rate)	$- 0.20 \times V_{DDQ}$	V	

Notes:

1. I_{OH} = -0.1mA.
2. I_{OL} = 0.1mA.

Single Ended Output Slew Rate

With the reference load for timing measurements, output slew rate for falling and rising edges is defined and measured between VOL(AC) and VOH(AC) for single ended signals as shown below.

Single-Ended Output Slew Rate Definition

Description	Defined by	Measured	
		From	To
Single-ended output slew rate for rising edge	$[VOH(AC) - VOL(AC)] / \Delta TR_{SE}$	VOL(AC)	VOH(AC)
Single-ended output slew rate for falling edge	$[VOH(AC) - VOL(AC)] / \Delta TF_{SE}$	VOH(AC)	VOL(AC)

Notes:

Output slew rate is verified by design and characterization, and may not be subject to production testing.

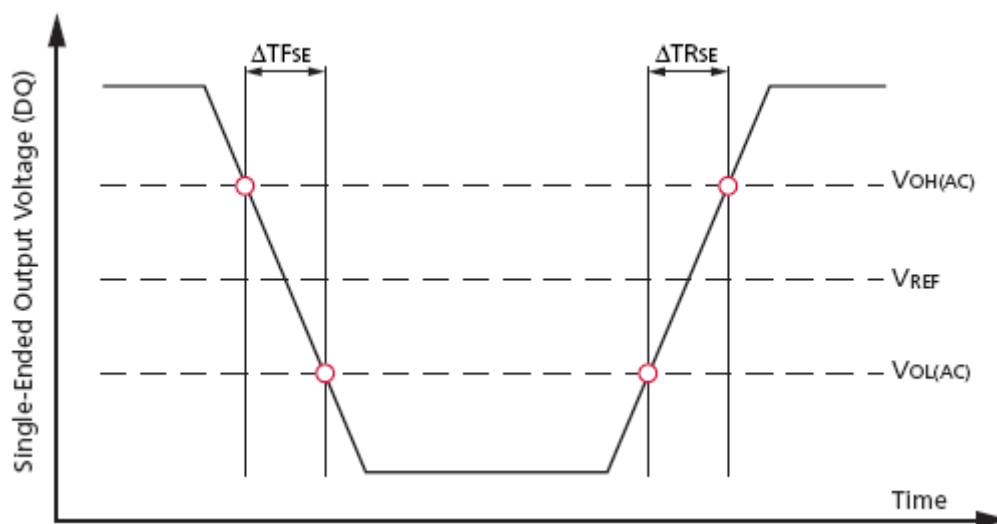

Single-Ended Output Slew Rate Definition

Single-Ended Output Slew Rate

Symbol	Parameter	LPDDR2 200-1066		Unit
		Min	Max	
SRQ _{SE}	Single-ended output slew rate (output impedance = 40Ω ± 30%)	1.5	3.5	V/ns
SRQ _{SE}	Single-ended output slew rate (output impedance = 60Ω ± 30%)	1.0	2.5	V/ns
	Output slew-rate-matching ratio (pull-up to pull-down)	0.7	1.4	

Definitions:

SR = slew rate, Q = query output (similar to DQ = data-in, query-output), se = single-ended signals

Notes:

1. Measured with output reference load.
2. The ratio of pull-up to pull-down slew rate is specified for the same temperature and voltage over the entire temperature and voltage range. For a given output, the ratio represents the maximum difference between pull-up and pull-down drivers due to process variation.
3. The output slew rate for falling and rising edges is defined and measured between $V_{OL(AC)}$ and $V_{OH(AC)}$.
4. Slew rates are measured under typical simultaneous switching output (SSO) conditions, with one-half of DQ signals per data byte driving HIGH and one-half of DQ signals per data byte driving LOW.

Differential Output Slew Rate

With the reference load for timing measurements, the output slew rate for falling and rising edges is defined and measured between $V_{OLdiff(AC)}$ and $V_{OHdiff(AC)}$ for differential signals as shown below.

Differential Input Slew Rate Definition

Description	Defined by	Measured	
		From	To
Differential output slew rate for rising edge	$[V_{OHdiff(AC)} - V_{OLdiff(AC)}] / \Delta TR_{diff}$	$V_{OLdiff(AC)}$	$V_{OHdiff(AC)}$
Differential output slew rate for falling edge	$[V_{OHdiff(AC)} - V_{OLdiff(AC)}] / \Delta TF_{diff}$	$V_{OHdiff(AC)}$	$V_{OLdiff(AC)}$

Notes:

Output slew rate is verified by design and characterization, and may not be subject to production testing.

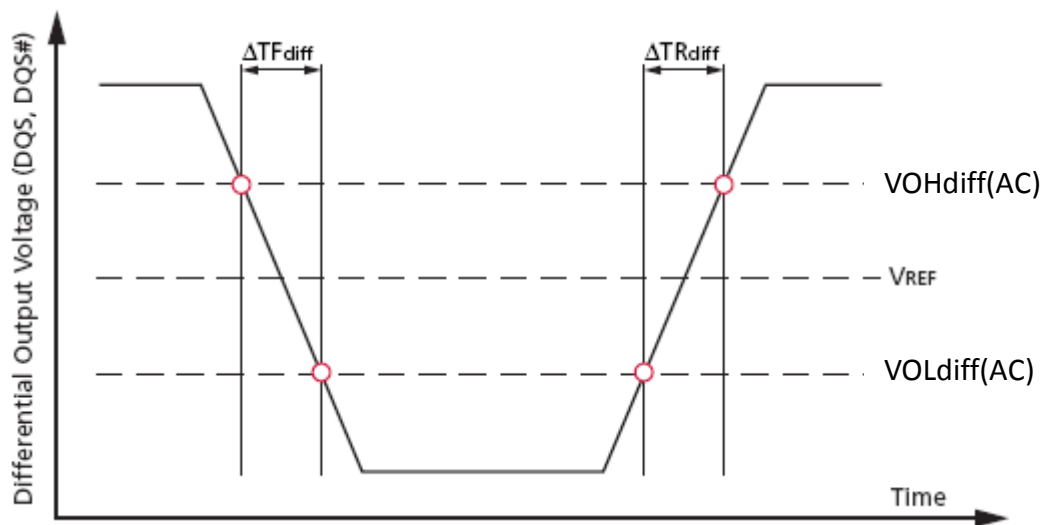

Differential Output Slew Rate Definition

Differential Input Slew Rate

Symbol	Parameter	LPDDR2 200-1066		Unit
		Min	Max	
SRQ_{diff}	Differential output slew rate (output impedance = $40\Omega \pm 30\%$)	3.0	7.0	V/ns
SRQ_{diff}	Differential output slew rate (output impedance = $60\Omega \pm 30\%$)	2.0	5.0	V/ns

Definitions:

SR = slew rate, Q = query output (similar to DQ = data-in, query-output), diff = differential signals

Notes:

1. Measured with output reference load.
2. The output slew rate for falling and rising edges is defined and measured between $V_{OL(AC)}$ and $V_{OH(AC)}$.
3. Slew rates are measured under typical simultaneous switching output (SSO) conditions, with one-half of DQ signals per data byte driving HIGH and one-half of DQ signals per data byte driving LOW.

AC Overshoot/Undershoot Specification

Parameter		1066	933	800	667	533	400	333	Unit
Maximum peak amplitude provided for overshoot area	Max	0.35							V
Maximum peak amplitude provided for undershoot area	Max	0.35							V
Maximum area above VDD	Max	0.15	0.17	0.20	0.24	0.30	0.40	0.48	V
Maximum area below Vss	Max	0.15	0.17	0.20	0.24	0.30	0.40	0.48	V

Notes:

1. VDD stands for VDDCA for CA[9:0], CK, \overline{CK} , \overline{CS} , and CKE. VDD stands for VDDQ for DQ, DM, DQS, and \overline{DQS} .
2. VSS stands for VSSCA for CA[9:0], CK, \overline{CK} , \overline{CS} , and CKE. VSS stands for VSSQ for DQ, DM, DQS, and \overline{DQS} .
3. Values are referenced from actual VDDQ, VDDCA, VSSQ and VSSCA levels.

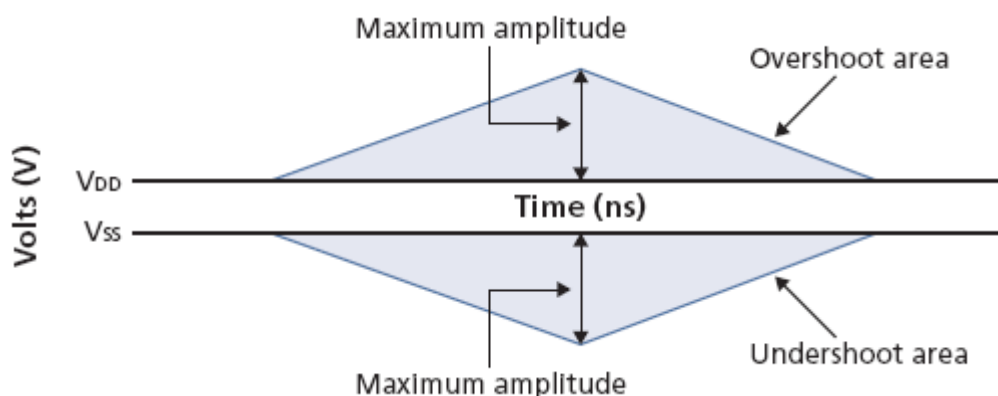

Overshoot and Undershoot Definition

Notes:

1. VDD stands for VDDCA for CA[9:0], CK, \overline{CK} , \overline{CS} , and CKE. VDD stands for VDDQ for DQ, DM, DQS, and \overline{DQS} .
2. VSS stands for VSSCA for CA[9:0], CK, \overline{CK} , \overline{CS} , and CKE. VSS stands for VSSQ for DQ, DM, DQS, and \overline{DQS} .

HSUL_12 Driver Output Timing Reference Load

The timing reference loads are not intended as a precise representation of any particular system environment or a depiction of the actual load presented by a production tester. System designers should use IBIS or other simulation tools to correlate the timing reference load to a system environment. Manufacturers correlate to their production test conditions, generally with one or more coaxial transmission lines terminated at the tester electronics.

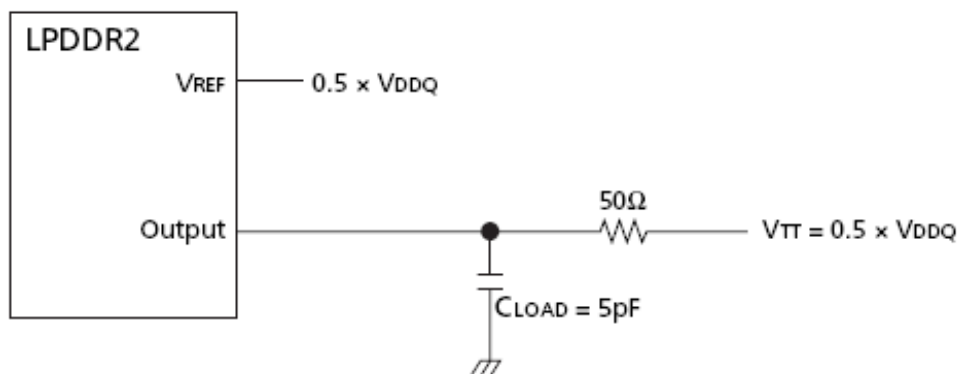

HSUL_12 Driver Output Reference Load for Timing and Slew Rate

Notes:

All output timing parameter values (tDQSCK, tDQSQ, tQHS, tHZ, tRPRE etc.) are reported with respect to this reference load. This reference load is also used to report slew rate.

Output Driver Impedance Definition

The output driver impedance is selected by a mode register during initialization. The selected value is able to maintain the tight tolerances specified if proper ZQ calibration is performed. Output specifications refer to the default output driver unless specifically stated otherwise. A functional representation of the output buffer is shown in below. The output driver impedance RON is defined by the value of the external reference resistor RZQ as follows:

$$R_{ONPU} = \frac{V_{DDQ} - V_{OUT}}{ABS(I_{OUT})}$$

When R_{ONPD} is turned off.

$$R_{ONPD} = \frac{V_{OUT}}{ABS(I_{OUT})}$$

When R_{ONPU} is turned off.

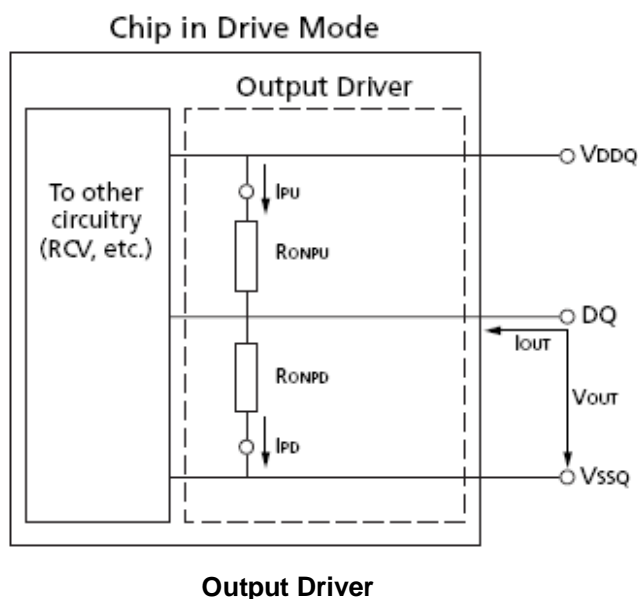

RON_{PU} and RON_{PD} Characteristics with ZQ Calibration

Output driver impedance RON is defined by the value of the external reference resistor RZQ. Typical RZQ is 240Ω.

Output Driver DC Electrical Characteristics with ZQ Calibration

RON _{nom}	Resistor	V _{OUT}	Min	Typ	Max	Unit
34.3Ω	RON34PD	0.5 × V _{DDQ}	29.2	34.3	39.4	Ω
	RON34PU	0.5 × V _{DDQ}	29.2	34.3	39.4	Ω
40.0Ω	RON40PD	0.5 × V _{DDQ}	34	40	46	Ω
	RON40PU	0.5 × V _{DDQ}	34	40	46	Ω
48.0Ω	RON48PD	0.5 × V _{DDQ}	40.8	48	55.2	Ω
	RON48PU	0.5 × V _{DDQ}	40.8	48	55.2	Ω
60.0Ω	RON60PD	0.5 × V _{DDQ}	51	60	69	Ω
	RON60PU	0.5 × V _{DDQ}	51	60	69	Ω
80.0Ω	RON80PD	0.5 × V _{DDQ}	68	80	92	Ω
	RON80PU	0.5 × V _{DDQ}	68	80	92	Ω
120.0Ω	RON120PD	0.5 × V _{DDQ}	102	120	138	Ω
	RON120PU	0.5 × V _{DDQ}	102	120	138	Ω
Mismatch between pull-up and pull-down	MM _{PUPD}		-15.00		+15.00	%

Notes:

1. Applies across entire operating temperature range after calibration.
2. R_{ZQ} = 240Ω.
3. The tolerance limits are specified after calibration, with fixed voltage and temperature. For behavior of the tolerance limits if temperature or voltage changes after calibration, see “Output Driver Temperature and Voltage Sensitivity”.
4. Pull-down and pull-up output driver impedances should be calibrated at 0.5 × V_{DDQ}.
5. Measurement definition for mismatch between pull-up and pull-down,

MM_{PUPD}: Measure RON_{PU} and RON_{PD}, both at 0.5 × V_{DDQ}:

$$MM_{PUPD} = \frac{R_{ONPU} - R_{ONPD}}{R_{ONNOM}} \times 100$$

For example, with MM_{PUPD} (MAX) = 15% and RON_{PD} = 0.85, RON_{PU} must be less than 1.0

Output Driver Temperature and Voltage Sensitivity

If temperature and/or voltage change after calibration, the tolerance limits widen as specified below.

Output Driver Sensitivity Definition

Resistor	V _{OUT}	Min	Max	Unit
RONPD	0.5 × V _{DDQ}	$85 - (dRONdT \times \Delta T) - (dRONdV \times \Delta V)$	$115 - (dRONdT \times \Delta T) + (dRONdV \times \Delta V)$	%
RONPU				

Notes:

1. $\Delta T = T - T(@ \text{ calibration})$. $\Delta V = V - V(@ \text{ calibration})$.
2. dRONdT and dRONdV are not subject to production testing; they are verified by design and characterization.

Output Driver Temperature and Voltage Sensitivity

Symbol	Parameter	Min	Max	Unit
dRONdT	RON temperature sensitivity	0.00	0.75	%/°C
dRONdV	RON voltage sensitivity	0.00	0.20	%/mV

Output Impedance Characteristics without ZQ Calibration

Output driver impedance is defined by design and characterization as the default setting.

Output Driver DC Electrical Characteristics without ZQ Calibration

R_{ONnom}	Resistor	V_{OUT}	Min	Typ	Max	Unit
34.3 Ω	RON34PD	$0.5 \times V_{DDQ}$	24	34.3	44.6	Ω
	RON34PU	$0.5 \times V_{DDQ}$	24	34.3	44.6	Ω
40.0 Ω	RON40PD	$0.5 \times V_{DDQ}$	28	40	52	Ω
	RON40PU	$0.5 \times V_{DDQ}$	28	40	52	Ω
48.0 Ω	RON48PD	$0.5 \times V_{DDQ}$	33.6	48	62.4	Ω
	RON48PU	$0.5 \times V_{DDQ}$	33.6	48	62.4	Ω
60.0 Ω	RON60PD	$0.5 \times V_{DDQ}$	42	60	78	Ω
	RON60PU	$0.5 \times V_{DDQ}$	42	60	78	Ω
80.0 Ω	RON80PD	$0.5 \times V_{DDQ}$	56	80	104	Ω
	RON80PU	$0.5 \times V_{DDQ}$	56	80	104	Ω
120.0 Ω	RON120PD	$0.5 \times V_{DDQ}$	84	120	156	Ω
	RON120PU	$0.5 \times V_{DDQ}$	84	120	156	Ω

Notes:

1. Applies across entire operating temperature range, without calibration.
2. $R_{zq} = 240 \Omega$.

RZQ I-V Curve

RZQ I-V curve

Voltage (V)	Ron = 240 Ω (Rzq)							
	Pull-Down				Pull-Up			
	Current (mA) / Ron (ohms)				Current (mA) / Ron (ohms)			
	Default Value after ZQRESET		With Calibration		Default Value after ZQRESET		With Calibration	
	Min (mA)	Max (mA)	Min (mA)	Max (mA)	Min (mA)	Max (mA)	Min (mA)	Max (mA)
0	0	0	0	0	0	0	0	0
0.05	0.19	0.32	0.21	0.26	-0.19	-0.32	-0.21	-0.26
0.1	0.38	0.64	0.4	0.53	-0.38	-0.64	-0.40	-0.53
0.15	0.56	0.94	0.6	0.78	-0.56	-0.94	-0.60	-0.78
0.2	0.74	1.26	0.79	1.04	-0.74	-1.26	-0.79	-1.04
0.25	0.92	1.57	0.98	1.29	-0.92	-1.57	-0.98	-1.29
0.3	1.08	1.86	1.17	1.53	-1.08	-1.86	-1.17	-1.53
0.35	1.25	2.17	1.35	1.79	-1.25	-2.17	-1.35	-1.79
0.4	1.4	2.46	1.52	2.03	-1.40	-2.46	-1.52	-2.03
0.45	1.54	2.74	1.69	2.26	-1.54	-2.74	-1.69	-2.26
0.5	1.68	3.02	1.86	2.49	-1.68	-3.02	-1.86	-2.49
0.55	1.81	3.3	2.02	2.72	-1.81	-3.30	-2.02	-2.72
0.6	1.92	3.57	2.17	2.94	-1.92	-3.57	-2.17	-2.94
0.65	2.02	3.83	2.32	3.15	-2.02	-3.83	-2.32	-3.15
0.7	2.11	4.08	2.46	3.36	-2.11	-4.08	-2.46	-3.36
0.75	2.19	4.31	2.58	3.55	-2.19	-4.31	-2.58	-3.55
0.8	2.25	4.54	2.7	3.74	-2.25	-4.54	-2.70	-3.74
0.85	2.3	4.74	2.81	3.91	-2.30	-4.74	-2.81	-3.91
0.9	2.34	4.92	2.89	4.05	-2.34	-4.92	-2.89	-4.05
0.95	2.37	5.08	2.97	4.23	-2.37	-5.08	-2.97	-4.23
1	2.41	5.2	3.04	4.33	-2.41	-5.20	-3.04	-4.33
1.05	2.43	5.31	3.09	4.44	-2.43	-5.31	-3.09	-4.44
1.1	2.46	5.41	3.14	4.52	-2.46	-5.41	-3.14	-4.52
1.15	2.48	5.48	3.19	4.59	-2.48	-5.48	-3.19	-4.59
1.2	2.5	5.55	3.23	4.65	-2.50	-5.55	-3.23	-4.65

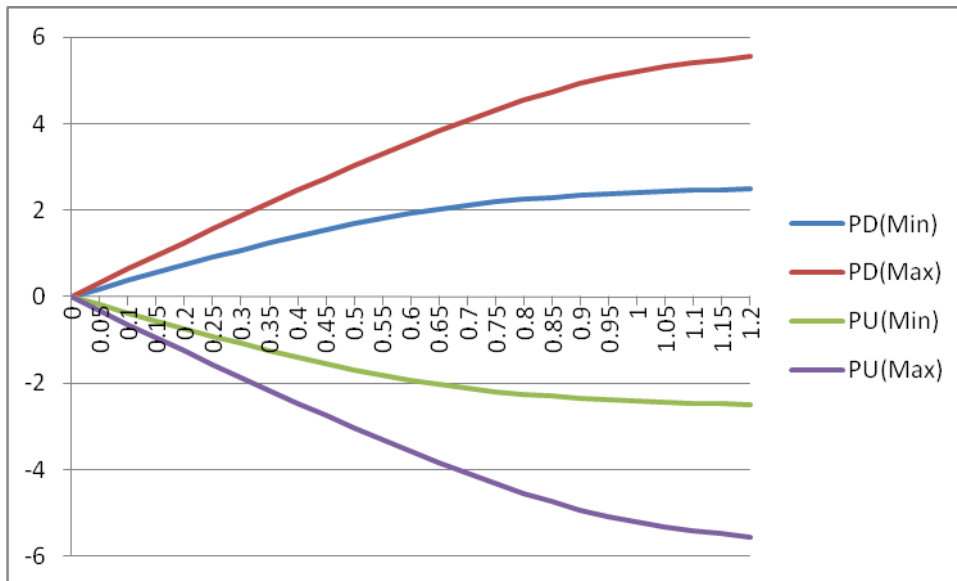

Output Impedance = 240 Ohms, I-V Curve after ZQRESET

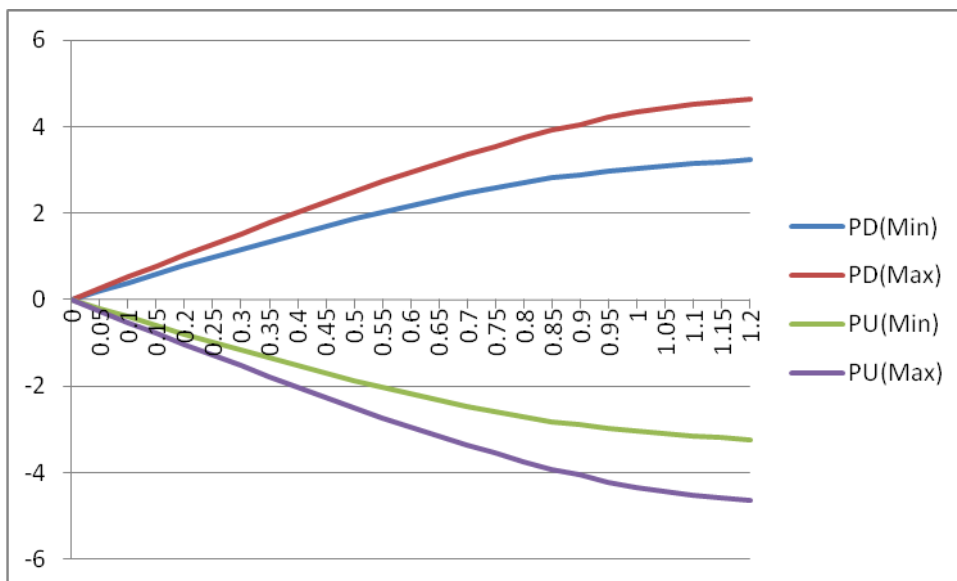

Output Impedance = 240 Ohms, I-V Curve after Calibration

Input / Output Capacitance

Symbol	Parameter	LPDDR2 1066-466		LPDDR2 400-200		Unit
		Min	Max	Min	Max	
C _{CK}	Input capacitance: CK, \overline{CK}	1	2	1	2	pF
C _{DCK}	Input capacitance delta: CK, \overline{CK}	0	0.2	0	0.25	pF
C _I	Input capacitance: all other input-only pins	1	2	1	2	pF
C _{DI}	Input capacitance delta: all other input-only pins	-0.4	0.4	-0.5	0.5	pF
C _{IO}	Input/output capacitance: DQ, DQS, \overline{DQS} , DM	1.25	2.5	1.25	2.5	pF
C _{DDQS}	Input/output capacitance delta: DQS, \overline{DQS}	0	0.25	0	0.3	pF
C _{DIO}	Input/output capacitance delta: DQ, DM	-0.5	0.5	-0.6	0.6	pF
C _{ZQ}	Input/output capacitance: ZQ	0	2.5	0	2.5	pF

Notes:

1. This parameter applies to die devices only (does not include package capacitance).
2. This parameter is not subject to production testing. It is verified by design and characterization. The capacitance is measured according to JEP147 (procedure for measuring input capacitance using a vector network analyzer), with VDD1, VDD2, VDDQ, VSS, VSSCA, and VSSQ applied; all other pins are left floating.
3. Absolute value of CCK - \overline{CCK} .
4. C_I applies to \overline{CS} , CKE, and CA[9:0].
5. C_{DI} = C_I - 0.5 × (CCK + \overline{CCK})
6. DM loading matches DQ and DQS.
7. MR3 I/O configuration DS OP[3:0] = 0001B (34.3 ohm typical)
8. Absolute value of CDQS and \overline{CDQS} .
9. C_{DIO} = C_{IO} - 0.5 × (CDQS + \overline{CDQS}) in byte-lane.
10. Maximum external load capacitance on ZQ pin, including packaging, board, pin, resistor, and other LPDDR2 devices: 5pF.

IDD Specification Parameters and Test Conditions

IDD Measurement Conditions

The following definitions and conditions are used in the IDD measurement tables unless stated otherwise:

- LOW: $V_{IN} \leq V_{IL(DC)max}$
- HIGH: $V_{IN} \geq V_{IH(DC)min}$
- STABLE: Inputs are stable at a HIGH or LOW level
- SWITCHING: See Tables below

Switching for CA Input Signal

	CK (Rising) / \overline{CK} (Falling)	CK (Falling) / \overline{CK} (Rising)	CK (Rising) / \overline{CK} (Falling)	CK (Falling) / \overline{CK} (Rising)	CK (Rising) / \overline{CK} (Falling)	CK (Falling) / \overline{CK} (Rising)	CK (Rising) / \overline{CK} (Falling)	CK (Falling) / \overline{CK} (Rising)
Cycle	N		N+1		N+2		N+3	
\overline{CS}	HIGH		HIGH		HIGH		HIGH	
CA0	H	L	L	L	L	H	H	H
CA1	H	H	H	L	L	L	L	H
CA2	H	L	L	L	L	H	H	H
CA3	H	H	H	L	L	L	L	H
CA4	H	L	L	L	L	H	H	H
CA5	H	H	H	L	L	L	L	H
CA6	H	L	L	L	L	H	H	H
CA7	H	H	H	L	L	L	L	H
CA8	H	L	L	L	L	H	H	H
CA9	H	H	H	L	L	L	L	H

Notes:

1. \overline{CS} must always be driven HIGH.
2. For each clock cycle, 50% of the CA bus is changing between HIGH and LOW.
3. The noted pattern (N, N + 1, N + 2, N + 3...) is used continuously during IDD measurement for IDD values that require switching on the CA bus.

IDD Measurement Conditions (Continued)

Switching for IDD4R

Clock	CKE	\overline{CS}	Clock Cycle Number	Command	CA[2:0]	CA[9:3]	All DQ
Rising	H	L	N	Read_Rising	HLH	LHLHLHL	L
Falling	H	L	N	Read_Falling	LLL	LLLLLLL	L
Rising	H	H	N+1	NOP	LLL	LLLLLLL	H
Falling	H	H	N+1	NOP	HLH	HLHLLHL	L
Rising	H	L	N+2	Read_Rising	HLH	HLHLLHL	H
Falling	H	L	N+2	Read_Falling	LLL	HHHHHHH	H
Rising	H	H	N+3	NOP	LLL	HHHHHHH	H
Falling	H	H	N+3	NOP	HLH	LHLHLHL	L

Notes:

1. Data strobe (DQS) is changing between HIGH and LOW with every clock cycle.
2. The noted pattern (N, N + 1...) is used continuously during IDD measurement for IDD4R.

Switching for IDD4W

Clock	CKE	\overline{CS}	Clock Cycle Number	Command	CA[2:0]	CA[9:3]	All DQ
Rising	H	L	N	Write_Rising	HLL	LHLHLHL	L
Falling	H	L	N	Write_Falling	LLL	LLLLLLL	L
Rising	H	H	N+1	NOP	LLL	LLLLLLL	H
Falling	H	H	N+1	NOP	HLH	HLHLLHL	L
Rising	H	L	N+2	Write_Rising	HLL	HLHLLHL	H
Falling	H	L	N+2	Write_Falling	LLL	HHHHHHH	H
Rising	H	H	N+3	NOP	LLL	HHHHHHH	H
Falling	H	H	N+3	NOP	HLH	LHLHLHL	L

Notes:

1. Data strobe (DQS) is changing between HIGH and LOW with every clock cycle.
2. Data masking (DM) must always be driven LOW.
3. The noted pattern (N, N + 1...) is used continuously during IDD measurement for IDD4W

IDD Specifications

IDD values are for the entire operating voltage range, and all of them are for the entire standard range with the exception of IDD6ET which is for entire extended temperature range.

LPDDR2 IDD Specification Parameters and Operating Conditions

Parameter/Condition	Symbol	Power Supply	Notes
Operating one bank active-precharge current (SDRAM): $t_{CK} = t_{CK(avg)min}$; $t_{RC} = t_{RCmin}$; CKE is HIGH; \overline{CS} is HIGH between valid commands; CA bus inputs are switching; Data bus inputs are stable	IDD01	VDD1	
	IDD02	VDD2	
	IDD0in	VDDCA, VDDQ	4
Idle power-down standby current: $t_{CK} = t_{CK(avg)min}$; CKE is LOW; \overline{CS} is HIGH; All banks are idle; CA bus inputs are switching; Data bus inputs are stable	IDD2P1	VDD1	
	IDD2P2	VDD2	
	IDD2P,in	VDDCA, VDDQ	4
Idle power-down standby current with clock stop: CK = LOW, $\overline{CK} = \text{HIGH}$; CKE is LOW; \overline{CS} is HIGH; All banks are idle; CA bus inputs are stable; Data bus inputs are stable	IDD2PS1	VDD1	
	IDD2PS2	VDD2	
	IDD2PS,in	VDDCA, VDDQ	4
Idle non-power-down standby current: $t_{CK} = t_{CK(avg)min}$; CKE is HIGH; \overline{CS} is HIGH; All banks are idle; CA bus inputs are switching; Data bus inputs are stable	IDD2N1	VDD1	
	IDD2N2	VDD2	
	IDD2N,in	VDDCA, VDDQ	4
Active power-down standby current: $t_{CK} = t_{CK(avg)min}$; CKE is LOW; \overline{CS} is HIGH; One bank is active; CA bus inputs are switching; Data bus inputs are stable	IDD3P1	VDD1	
	IDD3P2	VDD2	
	IDD3P,in	VDDCA, VDDQ	4
Active power-down standby current with clock stop: CK = LOW, $\overline{CK} = \text{HIGH}$; CKE is LOW; \overline{CS} is HIGH; One bank is active; CA bus inputs are stable; Data bus inputs are stable	IDD3PS1	VDD1	
	IDD3PSS2	VDD2	
	IDD3PS,in	VDDCA, VDDQ	4

IDD Specifications (Continued)

Parameter/Condition	Symbol	Power Supply	Notes
Active non-power-down standby current: $t_{CK} = t_{CK(ave)}min$; CKE is HIGH; \overline{CS} is HIGH; One bank is active; CA bus inputs are switching; Data bus inputs are stable	IDD3N1	VDD1	
	IDD3N2	VDD2	
	IDD3N,in	VDDCA,VDDQ	4
Operating burst READ current: $t_{CK} = t_{CK(ave)}min$; \overline{CS} is HIGH between valid commands; One bank is active; BL = 4; RL = RL (MIN); CA bus inputs are switching; 50% data change each burst transfer	IDD4R1	VDD1	
	IDD4R2	VDD2	
	IDD4R,in	VDDCA	
	IDD4RQ	VDDQ	5
Operating burst WRITE current: $t_{CK} = t_{CK(ave)}min$; \overline{CS} is HIGH between valid commands; One bank is active; BL = 4; WL = WLmin; CA bus inputs are switching; 50% data change each burst transfer	IDD4W1	VDD1	
	IDD4W2	VDD2	
	IDD4W,in	VDDCA,VDDQ	4
All-bank REFRESH burst current: $t_{CK} = t_{CK(ave)}min$ CKE is HIGH between valid commands; $t_{RC} = t_{RFCabmin}$; Burst refresh; CA bus inputs are switching; Data bus inputs are stable	IDD51	VDD1	
	IDD52	VDD2	
	IDD5IN	VDDCA,VDDQ	4
All-bank REFRESH average current: $t_{CK} = t_{CK(ave)}min$; CKE is HIGH between valid commands; $t_{RC} = t_{REFI}$; CA bus inputs are switching; Data bus inputs are stable	IDD5AB1	VDD1	
	IDD5AB2	VDD2	
	IDD5AB,in	VDDCA,VDDQ	4
Per-bank REFRESH average current: $t_{CK} = t_{CK(ave)}min$; CKE is HIGH between valid commands; $t_{RC} = t_{REFI}/8$; CA bus inputs are switching;Data bus inputs are stable	IDD5PB1	VDD1	6
	IDD5PB2	VDD2	6
	IDD5PB,in	VDDCA,VDDQ	4,6

IDD Specifications (Continued)

Parameter/Condition	Symbol	Power Supply	Notes
Self refresh current (–40°C to +85°C): CK = LOW, \overline{CK} = HIGH; CKE is LOW; CA bus inputs are stable; Data bus inputs are stable; Maximum 1x self refresh rate	IDD61	VDD1	7
	IDD62	VDD2	7
	IDD6IN	VDDCA, VDDQ	4,7
Self refresh current (+85°C to +105°C): CK = LOW, \overline{CK} = HIGH; CKE is LOW; CA bus inputs are stable; Data bus inputs are stable	IDD6ET1	VDD1	7,8
	IDD6ET2	VDD2	7,8
	IDD6ET,in	VDDCA, VDDQ	4,7,8
Deep power-down current: CK = LOW, \overline{CK} = HIGH; CKE is LOW; CA bus inputs are stable; Data bus inputs are stable	IDD81	VDD1	8
	IDD82	VDD2	8
	IDD8IN	VDDCA, VDDQ	4,8

Notes:

1. Published IDD values are the maximum of the distribution of the arithmetic mean.
2. IDD current specifications are tested after the device is properly initialized.
3. The 1x self refresh rate is the rate at which the device is refreshed internally during self refresh, before going into the extended temperature range.
4. Measured currents are the summation of VDDQ and VDDCA.
5. Guaranteed by design with output load of 5pF and RON = 40Ohm.
6. Per Bank Refresh only applicable for LPDDR2-S4 devices of 1Gb or higher densities
7. This is the general definition that applies to full-array SELF REFRESH).
8. IDD6ET and IDD8 are typical values, are sampled only, and are not tested.

IDD Specifications and Measurement Conditions

IDD Specifications; $V_{DD2}, V_{DDQ}, V_{DDCA} = 1.14\sim 1.30V, V_{DD1} = 1.70\sim 1.95V$

Symbol		Supply	Value	Unit	Notes
IDD0	I _{DD01}	V _{DD1}	9	mA	
	I _{DD02}	V _{DD2}	27.5		
	I _{DD0IN}	V _{DDCA} + V _{DDQ}	7.5		
IDD2P	I _{DD2P1}	V _{DD1}	220	uA	
	I _{DD2P2}	V _{DD2}	400		
	I _{DD2PIN}	V _{DDCA} + V _{DDQ}	50		
IDD2PS	I _{DD2PS1}	V _{DD1}	220	uA	
	I _{DD2PS2}	V _{DD2}	400		
	I _{DD2PSIN}	V _{DDCA} + V _{DDQ}	50		
IDD2N	I _{DD2N1}	V _{DD1}	2000	uA	
	I _{DD2N2}	V _{DD2}	10	mA	
	I _{DD2NIN}	V _{DDCA} + V _{DDQ}	7	mA	
IDD2NS	I _{DD2N1}	V _{DD1}	800	uA	
	I _{DD2N2}	V _{DD2}	2000	uA	
	I _{DD2SIN}	V _{DDCA} + V _{DDQ}	4.5	mA	
IDD3P	I _{DD3P1}	V _{DD1}	750	uA	
	I _{DD3P2}	V _{DD2}	2000	uA	
	I _{DD3PIN}	V _{DDCA} + V _{DDQ}	240	uA	
IDD3PS	I _{DD3PS1}	V _{DD1}	750	uA	
	I _{DD3PS2}	V _{DD2}	1500	uA	
	I _{DD3PSIN}	V _{DDCA} + V _{DDQ}	240	uA	
IDD3N	I _{DD3N1}	V _{DD1}	1000	uA	
	I _{DD3N2}	V _{DD2}	10	mA	
	I _{DD3NIN}	V _{DDCA} + V _{DDQ}	7	mA	
IDD3NS	I _{DD3N1}	V _{DD1}	1	mA	
	I _{DD3N2}	V _{DD2}	2	mA	
	I _{DD3SIN}	V _{DDCA} + V _{DDQ}	4.5	mA	
IDD4R	I _{DD4R1}	V _{DD1}	2	mA	
	I _{DD4R2}	V _{DD2}	130		
	I _{DD4RIN}	V _{DDCA}	6.5		

512Mb LPDDR2-S4 SDRAM

NT6TL16M32AQ/ NT6TL32M16AQ

IDD4W	I _{DD4W1}	V _{DD1}	2	mA	
	I _{DD4W2}	V _{DD2}	100		
	I _{DD4WIN}	V _{DDCA} + V _{DDQ}	20		
IDD5	I _{DD51}	V _{DD1}	22	mA	
	I _{DD52}	V _{DD2}	55		
	I _{DD5IN}	V _{DDCA} + V _{DDQ}	7		
IDD5AB	I _{DD5AB1}	V _{DD1}	1200	uA	
	I _{DD5AB2}	V _{DD2}	21	mA	
	I _{DD5ABIN}	V _{DDCA} + V _{DDQ}	6.7	mA	
IDD6	I _{DD61}	V _{DD1}	400	uA	
	I _{DD62}	V _{DD2}	550		
	I _{DD6IN}	V _{DDCA} + V _{DDQ}	40		
IDD8	I _{DD81}	V _{DD1}	25	uA	
	I _{DD82}	V _{DD2}	45		
	I _{DD8IN}	V _{DDCA} + V _{DDQ}	20		

IDD6 Partial Array Self-refresh current; V_{DD2}, V_{DDQ}, V_{DDCA} = 1.14~1.30V, V_{DD1} = 1.70~1.95V

PASR	Supply	Value	Unit	Notes
Full Array	V _{DD1}	400	uA	
	V _{DD2}	550		
	V _{DDCA} + V _{DDQ}	40		
1/2 Array	V _{DD1}	380		
	V _{DD2}	430		
	V _{DDCA} + V _{DDQ}	40		
1/4 Array	V _{DD1}	360		
	V _{DD2}	350		
	V _{DDCA} + V _{DDQ}	40		

Electrical Characteristic and AC Timing

Clock Specification

The specified clock jitter is a random jitter with Gaussian distribution. Input clocks violating minimum or maximum values may result in device malfunction.

Definitions and Calculations

Symbol	Description	Calculation	Notes
$t_{CK(avg)}$ and n_{CK}	The average clock period across any consecutive 200-cycle window. Each clock period is calculated from rising clock edge to rising clock edge. Unit $t_{CK(avg)}$ represents the actual clock average $t_{CK(avg)}$ of the input clock under operation. Unit n_{CK} represents one clock cycle of the input clock, counting from actual clock edge to actual clock edge. $t_{CK(avg)}$ can change no more than $\pm 1\%$ within a 100-clock-cycle window, provided that all jitter and timing specifications are met.	$t_{CK(avg)} = \left(\sum_{j=1}^N t_{CK_j} \right) / N$ Where $N = 200$	
$t_{CK(abs)}$	The absolute clock period, as measured from one rising clock edge to the next consecutive rising clock edge.		
$t_{CH(avg)}$	The average HIGH pulse width, as calculated across any 200 consecutive HIGH pulses.	$t_{CH(avg)} = \left(\sum_{j=1}^N t_{CH_j} \right) / (N \times t_{CK(avg)})$ Where $N = 200$	
$t_{CL(avg)}$	The average LOW pulse width, as calculated across any 200 consecutive LOW pulses.	$t_{CL(avg)} = \left(\sum_{j=1}^N t_{CL_j} \right) / (N \times t_{CK(avg)})$ Where $N = 200$	
$j_{JIT(per)}$	The single-period jitter defined as the largest deviation of any signal t_{CK} from $t_{CK(avg)}$.	$j_{JIT(per)} = \min/\max \text{ of } \left[t_{CK_i} - t_{CK(avg)} \right]$ Where $i = 1 \text{ to } 200$	
$j_{JIT(per),act}$	The actual clock jitter for a given system.		
$j_{JIT(per),allowed}$	The specified clock period jitter allowance.		
$j_{JIT(cc)}$	The absolute difference in clock periods between two consecutive clock cycles. $j_{JIT(cc)}$ defines the cycle-to-cycle jitter.	$j_{JIT(cc)} = \max \text{ of } \left[t_{CK_{i+1}} - t_{CK_i} \right]$	

Symbol	Description	Calculation	Notes
$t_{ERR(nper)}$	The cumulative error across n multiple consecutive cycles from $t_{CK(avg)}$.	$t_{ERR(nper)} = \left[\sum_{j=i}^{i+n-1} t_{CK_j} \right] - (n \times t_{CK(avg)})$	
$t_{ERR(nper),act}$	The actual cumulative error over n cycles for a given system.		
$t_{ERR(nper),allowed}$	The specified cumulative error allowance over n cycles.		
$t_{ERR(nper),min}$	The minimum $t_{ERR(nper)}$.	$t_{ERR(nper),min} = (1 + 0.68LN(n)) \times t_{JIT(per),min}$	
$t_{ERR(nper),max}$	The maximum $t_{ERR(nper)}$.	$t_{ERR(nper),max} = (1 + 0.68LN(n)) \times t_{JIT(per),max}$	
$t_{JIT(duty)}$	Defined with t_{CH} jitter and t_{CL} jitter. t_{CH} jitter is the largest deviation of any single t_{CH} from $t_{CH(avg)}$. t_{CL} jitter is the largest deviation of any single t_{CL} from $t_{CL(avg)}$.	$t_{JIT(duty)} = \min/\max \text{ of } [t_{JIT(CH)}, t_{JIT(CL)}]$ <p>Where:</p> $t_{JIT(CH)} = [t_{CH_i} - t_{CH(avg)} \text{ where } i = 1 \text{ to } 200]$ $t_{JIT(CL)} = [t_{CH_i} - t_{CH(avg)} \text{ where } i = 1 \text{ to } 200]$	

$t_{CK(abs)}$, $t_{CH(abs)}$ and $t_{CL(abs)}$

These parameters are specified per their average values, however, it is understood that the following relationship between the average timing and the absolute instantaneous timing holds at all times.

Symbol	Parameter	Minimum	Unit
$t_{CK(abs)}$	Absolute clock period	$t_{CK(avg),min} + t_{JIT(per),min}$	ps
$t_{CH(abs)}$	Absolute clock HIGH pulse width	$t_{CH(avg),min} + t_{JIT(duty),min} / t_{CK(avg),min}$	$t_{CK(avg)}$
$t_{CL(abs)}$	Absolute clock LOW pulse width	$t_{CL(avg),min} + t_{JIT(duty),min} / t_{CK(avg),min}$	$t_{CK(avg)}$

Notes:

1. $t_{CK(avg),min}$ is expressed in ps for this table.
2. $t_{JIT(duty),min}$ is a negative value.

Period Clock Jitter

LPDDR2 devices can tolerate some clock period jitter without core timing parameter derating. This section describes device timing requirements with clock period jitter (tJIT(per)) in excess of the values found in the AC timing table. Calculating cycle time derating and clock cycle derating are also described.

Clock Period Jitter Effects on Core Timing Parameters

Core timing parameters (tRCD, tRP, tRTP, tWR, tWRA, tWTR, tRC, tRAS, tRRD, tFAW) extend across multiple clock cycles. Period clock jitter impacts these parameters when measured in numbers of clock cycles. Within the specification limits, the device is characterized and verified to support $t_{nPARAM} = RU[t_{PARAM} / t_{CK}(avg)]$. During device operation where clock jitter is outside specification limits, the number of clocks or tCK(avg), may need to be increased based on the values for each core timing parameter.

Cycle Time Derating for Core Timing Parameters

For a given number of clocks (tnPARAM), for each core timing parameter, average clock period(tCK(avg)) and actual cumulative period error (tERR(tnPARAM), act) in excess of the allowed cumulative period error (tERR(tnPARAM),allowed) , the equation below calculates the amount of cycle time de-rating(in ns) required if the equation results in a positive value for a core timing parameter(tCORE). A cycle time de-rating analysis should be conducted for each core timing parameter. The amount of cycle time de-rating required is the maximum of the cycle time de-rating determined for each individual core timing parameter.

$$CycleTimeDerating = \max \left\{ \left[\frac{t_{PARAM} + t_{ERR}(t_{nPARAM}),act} - t_{ERR}(t_{nPARAM}),allowed}{t_{nPARAM}} - t_{CK}(avg) \right], 0 \right\}$$

Clock Cycle Derating for Core Timing Parameters

For each core timing parameter and a given number of clocks (tnPARAM), clock cycle derating should be specified with tJIT(per). For a given number of clocks (tnPARAM), for each core parameter, average clock period(tCK(avg)) and actual cumulative period error (tERR(tnPARAM),act) in excess of the allowed cumulative period error (tERR(tnPARAM),allowed), the equation below calculates the clock cycle derating (in clocks) required if the equation results in a positive value for a core timing parameter (tCORE), A clock cycle de-rating analysis should be conducted for each core timing parameter.

$$ClockCycleDerating = RU \left\{ \left[\frac{t_{PARAM} + t_{ERR}(t_{nPARAM}),act} - t_{ERR}(t_{nPARAM}),allowed}{t_{CK}(avg)} \right] - t_{nPARAM} \right\}$$

Clock Jitter Effects on Command/Address Timing Parameters

Command/address timing parameters (t_{IS} , t_{IH} , t_{ISCKE} , t_{IHCKE} , t_{ISb} , t_{IHb} , t_{ISCKEb} , t_{IHCKEb}) are measured from a command/address signal (CKE, CS, or CA[9:0]) transition edge to its respective clock signal (CK, \overline{CK}) crossing. The specification values are not affected by the $t_{JIT(per)}$ applied, as the setup and hold times are relative to the clock signal crossing that latches the command/address. Regardless of clock jitter values, these values must be met.

Clock Jitter Effects on READ Timing Parameters

t_{RPRE}

When the device is operated with input clock jitter, t_{RPRE} must be derated by the actual period jitter ($t_{JIT(per),act,max}$) of the input clock that exceeds the allowed period jitter ($t_{JIT(per),allowed,max}$). Output de-ratings are relative to the input clock.

$$t_{RPRE(min,derated)} = 0.9 - \left[\frac{t_{JIT(per),act,max} - t_{JIT(per),allowed,max}}{t_{CK(avg)}} \right]$$

For example, if the measured jitter into a LPDDR2-800 device has $t_{CK(avg)} = 2500ps$, $t_{JIT(per),act,min} = -172ps$, and $t_{JIT(per),act,max} = +193ps$, then $t_{RPRE,min, derated} = 0.9 - (t_{JIT(per), act,max} - t_{JIT(per), allowed,max})/t_{CK(avg)} = 0.9 - (193 - 100)/2500 = 0.8628 t_{CK(avg)}$.

$t_{LZ(DQ)}$, $t_{HZ(DQ)}$, t_{DQSCK} , $t_{LZ(DQS)}$, $t_{HZ(DQS)}$

These parameters are measured from a specific clock edge to a data signal transition (DM_n or DQ_m, where: n = 0, 1, 2, or 3; and m = DQ[31:0]), and specified timings must be met with respect to that clock edge. Therefore, they are not affected by $t_{JIT(per)}$.

t_{QSH} , t_{QSL}

These parameters are affected by duty cycle jitter, represented by $t_{CH(abs)min}$ and $t_{CL(abs)min}$. Therefore $t_{QSH(abs)min}$ and $t_{QSL(abs)min}$ can be specified with $t_{CH(abs)min}$ and $t_{CL(abs)min}$. $t_{QSH(abs)min} = t_{CH(abs)min} - 0.05$, $t_{QSL(abs)min} = t_{CL(abs)min} - 0.05$. These parameters determine the absolute data-valid window at the device pin. The absolute minimum data-valid window @ the device pin = $\min [(t_{QSH(abs)min} \times t_{CK(avg)min} - t_{DQSQmax} - t_{QHSmax}), (t_{QSL(abs)min} \times t_{CK(avg)min} - t_{DQSQmax} - t_{QHSmax})]$. This minimum data-valid window must be met at the target frequency regardless of clock jitter.

tRPST

tRPST is affected by duty cycle jitter, represented by tCL(abs). Therefore, tRPST(abs)min can be specified by tCL(abs)min. tRPST(abs)min = tCL(abs)min - 0.05 = tQSL(abs)min.

Clock Jitter Effects on WRITE Timing Parameters

tDS, tDH

These parameters are measured from a data signal (DMn or DQm, where n = 0, 1, 2, 3; and m = DQ[31:0]) transition edge to its respective data strobe signal (DQSn, \overline{DQSn} ; n = 0,1,2,3) crossing. The specification values are not affected by the amount of tJIT(per) applied, as the setup and hold times are relative to the clock signal crossing that latches the command/address. Regardless of clock jitter values, these values must be met.

tDSS, tDSH

These parameters are measured from a data strobe signal (DQSx, \overline{DQSx}) crossing to its respective clock signal (CK, \overline{CK}) crossing. The specification values are not affected by the amount of tJIT(per) applied, as the setup and hold times are relative to the clock signal crossing that latches the command/address. Regardless of clock jitter values, these values must be met.

tDQSS

This parameter is measured from the clock signal (CK, \overline{CK}) crossing to the first latching data strobe signal (DQSx, \overline{DQSx}) crossing. When the device is operated with input clock jitter, this parameter must be derated by the actual period jitter (tJIT(per),act) of the input clock in excess of the allowed period jitter (tJIT(per),allowed).

$$t_{DQSS(min,derated)} = 0.75 - \left(\frac{t_{JIT(per),act,min} - t_{JIT(per),allowed,min}}{t_{CK(avg)}} \right)$$

$$t_{DQSS(max,derated)} = 1.25 - \left(\frac{t_{JIT(per),act,max} - t_{JIT(per),allowed,max}}{t_{CK(avg)}} \right)$$

For example, if the measured jitter into an LPDDR2-800 device has tCK(avg) = 2500ps, tJIT(per),act,min = -172ps, and tJIT(per),act,max = +193ps, then:

$$t_{DQSS,(min,derated)} = 0.75 - (t_{JIT(per),act,min} - t_{JIT(per),allowed,min})/t_{CK(avg)} = 0.75 - (-172 + 100)/2500 = 0.7788 t_{CK(avg)},$$

And

$$t_{DQSS,(max,derated)} = 1.25 - (t_{JIT(per),act,max} - t_{JIT(per),allowed,max})/t_{CK(avg)} = 1.25 - (193 - 100)/2500 = 1.2128 t_{CK(avg)}.$$

Electrical Characteristics and Recommended AC Timing

$V_{DD2}, V_{DDQ}, V_{DDCA} = 1.14\sim 1.30V, V_{DD1} = 1.70\sim 1.95V$

Symbol	Parameter	Min/ Max	Min t_{CK}	Speed Grade			Unit
				1066	800	667	
Clock parameters							
f	Frequency	max		533	400	333	MHz
t_{CK}	Clock cycle time	min		1.8	2.5	3	ns
		max		100			ns
t_{CH}	CK high-level width	min		0.45			t_{CK}
		max		0.55			t_{CK}
t_{CL}	CK low-level width	min		0.45			t_{CK}
		max		0.55			t_{CK}
t_{HP}	Half-clock period	=		min(t_{CH}, t_{CL})			t_{CK}
$t_{CK(avg)}$	Average Clock period	min		1.875	2.5	3	$t_{CK(avg)}$
		max		100			
$t_{CH(avg)}$	Average HIGH pulse width	min		0.45			$t_{CK(avg)}$
		max		0.55			

Symbol	Parameter	Min/ Max	Min t _{CK}	Speed Grade			Unit
				1066	800	667	
t _{CL(avg)}	Average LOW pulse width	min		0.45			t _{CK(avg)}
		max		0.55			
t _{CK(abs)}	Absolute clock period	min		t _{CK(avg)} MIN ± t _{JIT(per)} MIN			ps
t _{CH(abs)}	Absolute clock HIGH pulse width	min		0.43			t _{CK(avg)}
t _{CL(abs)}	Absolute clock LOW pulse width	min		0.43			t _{CK(avg)}
t _{JIT(per), allowed}	Clock period jitter (with supported jitter)	min		-90	-100	-110	ps
		max		-90	-100	-110	ps
t _{ERR(2per), allowed}	Cumulative errors across 2 cycles	min		-132	-147	-162	ps
		max		132	147	162	ps
t _{ERR(3per), allowed}	Cumulative errors across 3 cycles	min		-157	-175	-192	ps
		max		157	175	192	ps
t _{ERR(4per), allowed}	Cumulative errors across 4 cycles	min		-175	-194	-214	ps
		max		175	194	214	ps
t _{ERR(5per), allowed}	Cumulative errors across 5 cycles	min		-188	-209	-230	ps
		max		188	209	230	ps
t _{ERR(6per), allowed}	Cumulative errors across 6 cycles	min		-200	-222	-244	ps
		max		200	222	244	ps
t _{ERR(7per), allowed}	Cumulative errors across 7 cycles	min		-209	-232	-256	ps
		max		209	232	256	ps
t _{ERR(8per), allowed}	Cumulative errors across 8 cycles	min		-217	-241	-266	ps
		max		217	241	266	ps
t _{ERR(9per), allowed}	Cumulative errors across 9 cycles	min		-224	-249	-274	ps
		max		224	249	274	ps
t _{ERR(10per), allowed}	Cumulative errors across 10 cycles	min		-231	-257	-282	ps
		max		231	257	282	ps
t _{ERR(11per), allowed}	Cumulative errors across 11 cycles	min		-237	-263	-289	ps
		max		237	263	289	ps
t _{ERR(12per), allowed}	Cumulative errors across 12 cycles	min		-242	-269	-296	ps
		max		242	269	296	ps
t _{ERR(nper), allowed}	Cumulative errors across n = 13, 14, 15..., 49, 50 cycles	min		t _{ERR(nper),allowed} MIN = (1 + 0.68ln(n)) × t _{JIT(per),allowed} MIN			ps
		max		t _{ERR(nper),allowed} MAX = (1 + 0.68ln(n)) × t _{JIT(per),allowed} MAX			ps

Symbol	Parameter	Min/ Max	Min t _{CK}	Speed Grade			Unit
				1066	800	667	
ZQ calibration parameters							
t _{ZQinit}	Calibration initialization Time	min		1			us
t _{ZQCL}	Long (Full) Calibration Time	min		360			ns
t _{ZQCS}	Short Calibration Time	min		90			ns
t _{ZQreset}	Calibration Reset Time	Min	3	50			ns
Read parameters							
t _{DQSK}	DQS output access time from CK, /CK	Min		2500			ps
		Max		5500			ps
t _{DQSKDS}	DQSK Delta Short	Max		330	450	540	ps
t _{DQSKDM}	DQSK Delta Medium	Max		680	900	1050	ps
t _{DQSKDL}	DQSK Long	Max		920	1200	1400	ps
t _{DQSQ}	DQS-DQ skew, DQS to last DQ valid, per group, per access	Max		200	240	280	ps
t _{QHS}	Data Hold Skew Factor	Max		230	280	340	ps
t _{QSH}	DQS output HIGH pulse width	Min		t _{CH} - 0.05			t _{CK}
t _{QSL}	DQS output LOW pulse width	Min		t _{CL} - 0.05			t _{CK}
t _{QHP}	Data half period	Min		MIN (t _{QSH} , t _{QSL})			t _{CK}
t _{QH}	DQ-DQS hold, DQS to first DQ to go non-valid, per access	Min		t _{HP} - t _{QHS}			ps
t _{RPRE}	READ Preamble	Min		0.9			t _{CK}
t _{RPST}	READ postamble	Min		t _{CL} - 0.05			t _{CK}
t _{LZ(DQS)}	DQS Low-Z from CK	Min		t _{DQSK} _{min} - 300			ps
t _{LZ(DQ)}	DQ Low-Z from CK	Min		t _{DQSK} (MIN) - (1.4 × t _{QHS} (MAX))			ps
t _{HZ(DQS)}	DQS High-Z from CK	Max		t _{DQSK} _{max} - 100			ps
t _{HZ(DQ)}	DQ High-Z from CK	Max		t _{DQSK} (MAX) + (1.4 × t _{DQSQ} (MAX))			ps
Write parameters							
t _{DH}	DQ and DM input hold time (V _{REF} based)	Min		210	270	350	ps
t _{DS}	DQ and DM input setup time (V _{REF} based)	Min		210	270	350	ps
t _{DIPW}	DQ and DM input pulse width	Min		0.35			t _{CK}
t _{DQSS}	Write command to 1st DQS latching transition	Min		0.75			t _{CK}
		Max		1.25			t _{CK}
t _{DQSH}	DQS input high-level width	Min		0.4			t _{CK}
t _{DQSL}	DQS input low-level width	Min		0.4			t _{CK}

Symbol	Parameter	Min/Max	Min t _{CK}	Speed Grade			Unit
				1066	800	667	
t _{DSS}	DQS falling edge to CK setup time	Min		0.2			t _{CK}
t _{DSH}	DQS falling edge hold time from CK	Min		0.2			t _{CK}
t _{WPST}	Write postamble	Min		0.4			t _{CK}
t _{WPRE}	Write preamble	Min		0.35			t _{CK}
CKE input parameters							
t _{CKE}	CKE min. pulse width (high and low)	Min	3	3			t _{CK}
t _{ISCKE}	CKE input set-up time	Min		0.25			t _{CK}
t _{IHCKE}	CKE input hold time	Min		0.25			t _{CK}
Command / Address Input parameters							
t _{IH}	Address and Control input hold time	Min		220	290	370	ps
t _{IS}	Address and Control input setup time	Min		220	290	370	ps
t _{IPW}	Address and Control input pulse width	Min		0.4			t _{CK}
Mode register parameters							
t _{MRR}	MODE Register Read command period	Min	2	2			t _{CK}
t _{MRW}	MODE Register Write command period	Min	5	5			t _{CK}
SDRAM core parameters							
RL	Read Latency	Min	3	8	6	5	t _{CK}
WL	Write Latency	Min	1	4	3	2	t _{CK}
t _{CKESR}	CKE minimum pulse width during SELF REFRESH (low pulse width during SELF REFRESH)	Min	3	15			ns
t _{XSR}	Exit SELF REFRESH to first valid command (min)	min	2	t _{RFC_{AB}} +10			ns
t _{XP}	Exit power-down mode to first valid command	min	2	7.5			ns
t _{DPD}	Minimum Deep Power-Down time	min	-	500			us
t _{FAW}	Four-Bank Activate Window	min	8	50			ns
t _{WTR}	Internal WRITE to READ command delay	min	2	7.5			ns
t _{RC}	ACTIVE to ACTIVE command period	min		t _{RAS} + t _{RP_{AB}} (with all-bank Precharge) t _{RAS} + t _{RP_{PB}} (with per-bank Precharge)			ns
t _{CCD}	CAS-to-CAS delay	min	2	2			t _{CK}
t _{RTP}	Internal READ to PRECHARGE command delay	min	2	7.5			ns
t _{RCD}	RAS-to-CAS delay	min	3	15			ns
t _{RAS}	Row Active Time	min	3	42			ns
		max	-	70			us

Symbol	Parameter	Min/ Max	Min t _{CK}	Speed Grade			Unit
				1066	800	667	
				t _{WR}	Write recovery time	min	
t _{RP_{PB}}	PRECHARGE command period (single bank)	min	3	15			ns
t _{RP_{PAB}}	PRECHARGE command period (all banks – 8bnak)	min	3	18			ns
t _{RRD}	ACTIVE <i>bank-a</i> to ACTIVE <i>bank-b</i> command	min	2	10			ns

Temperature Derating

t _{DQ_{SCK}} (derated)	t _{DQ_{SCK}} derating	max		5620	6000	6000	ps
t _{RCD} (derated)	Core timing temperature derating	min		t _{RCD} + 1.875			ns
t _{RC} (derated)		min		t _{RC} + 1.875			ns
t _{RAS} (derated)		min		t _{RAS} + 1.875			ns
t _{RP} (derated)		min		t _{RP} + 1.875			ns
t _{RRD} (derated)		min		t _{RRD} + 1.875			ns

Boot parameters (10MHz ~ 55MHz)

t _{CK_b}	Clock cycle time	min		18			ns
		max		100			ns
t _{ISCKE_b}	CKE input setup time	min		2.5			ns
t _{IHCKE_b}	CKE input hold time	min		2.5			ns
t _{IS_b}	Input setup time	min		1150			ps
t _{IH_b}	Input hold time	min		1150			ps
t _{DQ_{SCK_b}}	Access window of DQS from CK, /CK	min		2.0			ns
		max		10.0			ns
t _{DQ_{SQ_b}}	DQS-DQ skew	max		1.2			ns
t _{QHS_b}	Data hold skew factor	max		1.2			ns

Notes:

1. Frequency values are for reference only. Clock cycle time (t_{CK}) is used to determine device capabilities.
2. All AC timings assume an input slew rate of 1 V/ns.
3. READ, WRITE, and input setup and hold values are referenced to V_{REF}.
4. t_{DQ_{SCKDS}} is the absolute value of the difference between any two t_{DQ_{SCK}} measurements (in a byte lane) within a contiguous sequence of bursts in a 160ns rolling window. t_{DQ_{SCKDS}} is not tested and is guaranteed by design. Temperature drift in the system is < 10°C/s. Values do not include clock jitter.
5. t_{DQ_{SCKDM}} is the absolute value of the difference between any two t_{DQ_{SCK}} measurements (in a byte lane) within a 1.6µs rolling window. t_{DQ_{SCKDM}} is not tested and is guaranteed by design. Temperature drift in the system is < 10 °C/s. Values do not include clock jitter.
6. t_{DQ_{SCKDL}} is the absolute value of the difference between any two t_{DQ_{SCK}} measurements (in a byte lane) within a 32ms rolling window. t_{DQ_{SCKDL}} is not tested and is guaranteed by design. Temperature drift in the system is < 10 °C/s. Values do

not include clock jitter.

7. For LOW-to-HIGH and HIGH-to-LOW transitions, the timing reference is at the point when the signal crosses the transition threshold (V_{TT}). t_{HZ} and t_{LZ} transitions occur in the same access time (with respect to clock) as valid data transitions. These parameters are not referenced to a specific voltage level but to the time when the device output is no longer driving (for t_{RPST} , $t_{HZ}(DQS)$ and $t_{HZ}(DQ)$), or begins driving (for t_{RPRE} , $t_{LZ}(DQS)$, $t_{LZ}(DQ)$). Figure shows a method to calculate the point when device is no longer driving $t_{HZ}(DQS)$ and $t_{HZ}(DQ)$, or begins driving $t_{LZ}(DQS)$, $t_{LZ}(DQ)$ by measuring the signal at two different voltages. The actual voltage measurement points are not critical as long as the calculation is consistent.

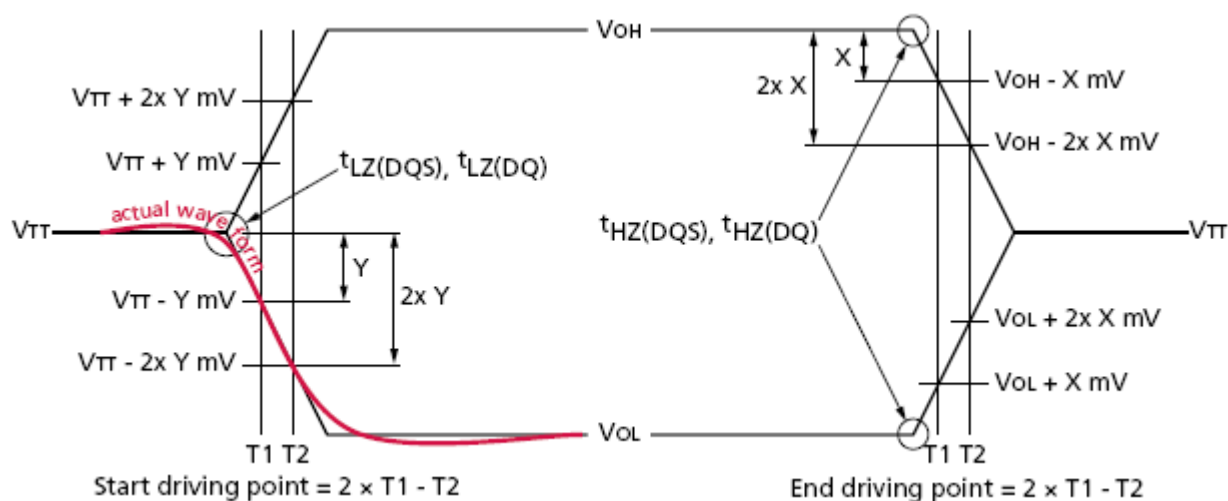

Data Out measurement reference points

The parameters $t_{LZ}(DQS)$, $t_{LZ}(DQ)$, $t_{HZ}(DQS)$, and $t_{HZ}(DQ)$ are defined as single-ended. The timing parameters t_{RPRE} and t_{RPST} are determined from the differential signal DQS, \overline{DQS} .

8. Measured from the point when DQS, \overline{DQS} begins driving the signal to the point when DQS, \overline{DQS} begins driving the first rising strobe edge.
9. Measured from the last falling strobe edge of DQS, \overline{DQS} to the point when DQS, \overline{DQS} finishes driving the signal.
10. CKE input setup time is measured from CKE reaching a HIGH/LOW voltage level to CK, \overline{CK} crossing.
11. CKE input hold time is measured from CK, \overline{CK} crossing to CKE reaching a HIGH/LOW voltage level.
12. Input set-up/hold time for signal ($CA[9:0], \overline{CS}$).
13. To ensure device operation before the device is configured, a number of AC boot-timing parameters are defined in this table. Boot parameter symbols have the letter b appended (for example, t_{CK} during boot is t_{CKb}).
14. The LPDDR device will set some mode register default values upon receiving a RESET (MRW) command as specified in "Mode Register Definition".
15. The output skew parameters are measured with default output impedance settings using the reference load.
16. The minimum t_{CK} column applies only when t_{CK} is greater than 6ns.
17. Timing derating applies for operation at 85°C to 105°C when the requirement to derate is indicated by mode register 4 op-code.

CA and \overline{CS} Setup, Hold, and Derating

The For all input signals (CA and \overline{CS}), the total required setup time (tIS) and hold time (tIH) is calculated by adding the data sheet tIS (base) and tIH (base) values to the ΔtIS and ΔtIH derating values, respectively. Example: tIS (total setup time) = tIS(base) + ΔtIS .

Setup (tIS) typical slew rate for a rising signal is defined as the slew rate between the last crossing of $V_{REF(DC)}$ and the first crossing of $V_{IH(AC)min}$. The setup (tIS) typical slew rate for a falling signal is defined as the slew rate between the last crossing of $V_{REF(DC)}$ and the first crossing of $V_{IL(AC)max}$. If the actual signal is always earlier than the typical slew rate line between the shaded $V_{REF(DC)}$ -to-(AC) region, use the typical slew rate for the derating value. If the actual signal is later than the typical slew rate line anywhere between the shaded $V_{REF(DC)}$ -to-AC region, the slew rate of a tangent line to the actual signal from the AC level to the DC level is used for the derating value.

The hold (tIH) typical slew rate for a rising signal is defined as the slew rate between the last crossing of $V_{IL(DC)max}$ and the first crossing of $V_{REF(DC)}$. The hold (tIH) typical slew rate for a falling signal is defined as the slew rate between the last crossing of $V_{IH(DC)min}$ and the first crossing of $V_{REF(DC)}$. If the actual signal is always later than the typical slew rate line between the shaded DC-to- $V_{REF(DC)}$ region, use the typical slew rate for the derating value. If the actual signal is earlier than the typical slew rate line anywhere between the shaded DC-to- $V_{REF(DC)}$ region, the slew rate of a tangent line to the actual signal from the DC level to $V_{REF(DC)}$ level is used for the derating value.

For a valid transition, the input signal must remain above or below $V_{IH}/V_{IL(AC)}$ for a specified time, $tVAC$. For slow slew rates the total setup time could be a negative value (that is, a valid input signal will not have reached $V_{IH}/V_{IL(AC)}$ at the time of the rising clock transition). A valid input signal is still required to complete the transition and reach $V_{IH}/V_{IL(AC)}$.

For slew rates between the values listed, the derating values are obtained using linear interpolation. Slew rate values are not typically subject to production testing. They are verified by design and characterization.

CA and \overline{CS} Setup and Hold Base Values (> 400 MHz, 1 V/ns slew rate)

Parameter	Data Rate				Reference
	1066	800	667	533	
tIS (base)	0	70	150	240	$V_{IH}/V_{IL(AC)} = V_{REF(DC)} \pm 220mV$
tIH (base)	90	160	240	330	$V_{IH}/V_{IL(DC)} = V_{REF(DC)} \pm 130mV$

Notes: AC/DC referenced for 1 V/ns CA and \overline{CS} slew rate and 2 V/ns differential CK, \overline{CK} slew rate.

512Mb LPDDR2-S4 SDRAM

NT6TL16M32AQ/ NT6TL32M16AQ

CA and \overline{CS} Setup, Hold, and Derating (Continued)

Derating Values for AC/DC-based t_{IS}/t_{IH} (AC220) - Δt_{IS} , Δt_{IH} derating in [ps], AC/DC-based

		CK, CK# Differential Slew Rate															
		4.0 V/ns		3.0 V/ns		2.0 V/ns		1.8 V/ns		1.6 V/ns		1.4 V/ns		1.2 V/ns		1.0 V/ns	
		Δt_{IS}	Δt_{IH}	Δt_{IS}	Δt_{IH}	Δt_{IS}	Δt_{IH}	Δt_{IS}	Δt_{IH}	Δt_{IS}	Δt_{IH}	Δt_{IS}	Δt_{IH}	Δt_{IS}	Δt_{IH}	Δt_{IS}	Δt_{IH}
CA, CS# slew rate V/ns	2.0	110	65	110	65	110	65										
	1.5	74	43	73	43	73	43	89	59								
	1.0	0	0	0	0	0	0	16	16	32	32						
	0.9			-3	-5	-3	-5	13	11	29	27	45	43				
	0.8					-8	-13	8	3	24	19	40	35	56	55		
	0.7							2	-6	18	10	34	26	50	46	66	78
	0.6									10	-3	26	13	42	33	58	65
	0.5											4	-4	20	16	36	48
	0.4													-7	2	17	34

Notes: Cell contents shaded in green are defined as "not supported."

Derating Values for AC/DC-based t_{IS}/t_{IH} (AC300) - Δt_{IS} , Δt_{IH} derating in [ps], AC/DC-based

		CK, CK# Differential Slew Rate															
		4.0 V/ns		3.0 V/ns		2.0 V/ns		1.8 V/ns		1.6 V/ns		1.4 V/ns		1.2 V/ns		1.0 V/ns	
		Δt_{IS}	Δt_{IH}	Δt_{IS}	Δt_{IH}	Δt_{IS}	Δt_{IH}	Δt_{IS}	Δt_{IH}	Δt_{IS}	Δt_{IH}	Δt_{IS}	Δt_{IH}	Δt_{IS}	Δt_{IH}	Δt_{IS}	Δt_{IH}
CA, CS# slew rate V/ns	2.0	150	100	150	100	150	100										
	1.5	100	67	100	67	100	67	116	83								
	1.0	0	0	0	0	0	0	16	16	32	32						
	0.9			-4	-8	-4	-8	12	8	28	24	44	40				
	0.8					-12	-20	4	-4	20	12	36	28	52	48		
	0.7							-3	-18	13	-2	29	14	45	34	61	66
	0.6									2	-21	18	-5	34	15	50	47
	0.5											-12	-32	4	-12	20	20
	0.4													-35	-40	-11	-8

Notes: Cell contents shaded in green are defined as "not supported."

Required Time for Valid Transition with t_{VAC} Above $V_{IH}(AC)$ and Below $V_{IL}(AC)$

Slew Rate (V/ns)	t_{VAC} at 300mV (ps)		t_{VAC} at 220mV (ps)	
	Min	Max	Min	Max
>2.0	75	-	175	-
2	57	-	170	-
1.5	50	-	167	-
1	38	-	163	-
0.9	34	-	162	-
0.8	29	-	161	-
0.7	22	-	159	-
0.6	13	-	155	-
0.5	0	-	150	-
<0.5	0	-	150	-

CA and \overline{CS} Setup, Hold, and Derating (Continued)

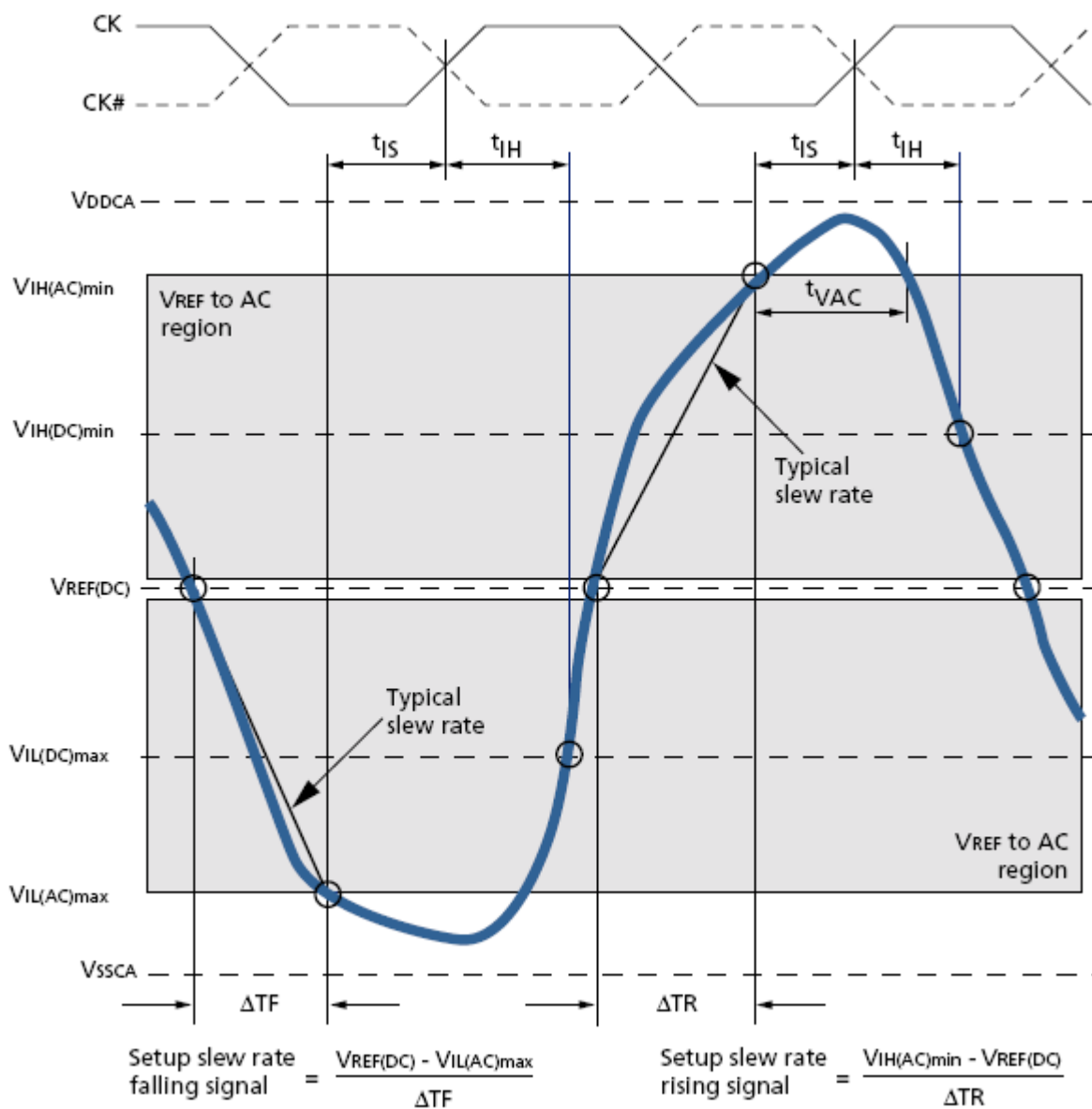

Typical Slew Rate and t_{VAC} : t_{IS} for CA and \overline{CS} Relative to Clock

CA and \overline{CS} Setup, Hold, and Derating (Continued)

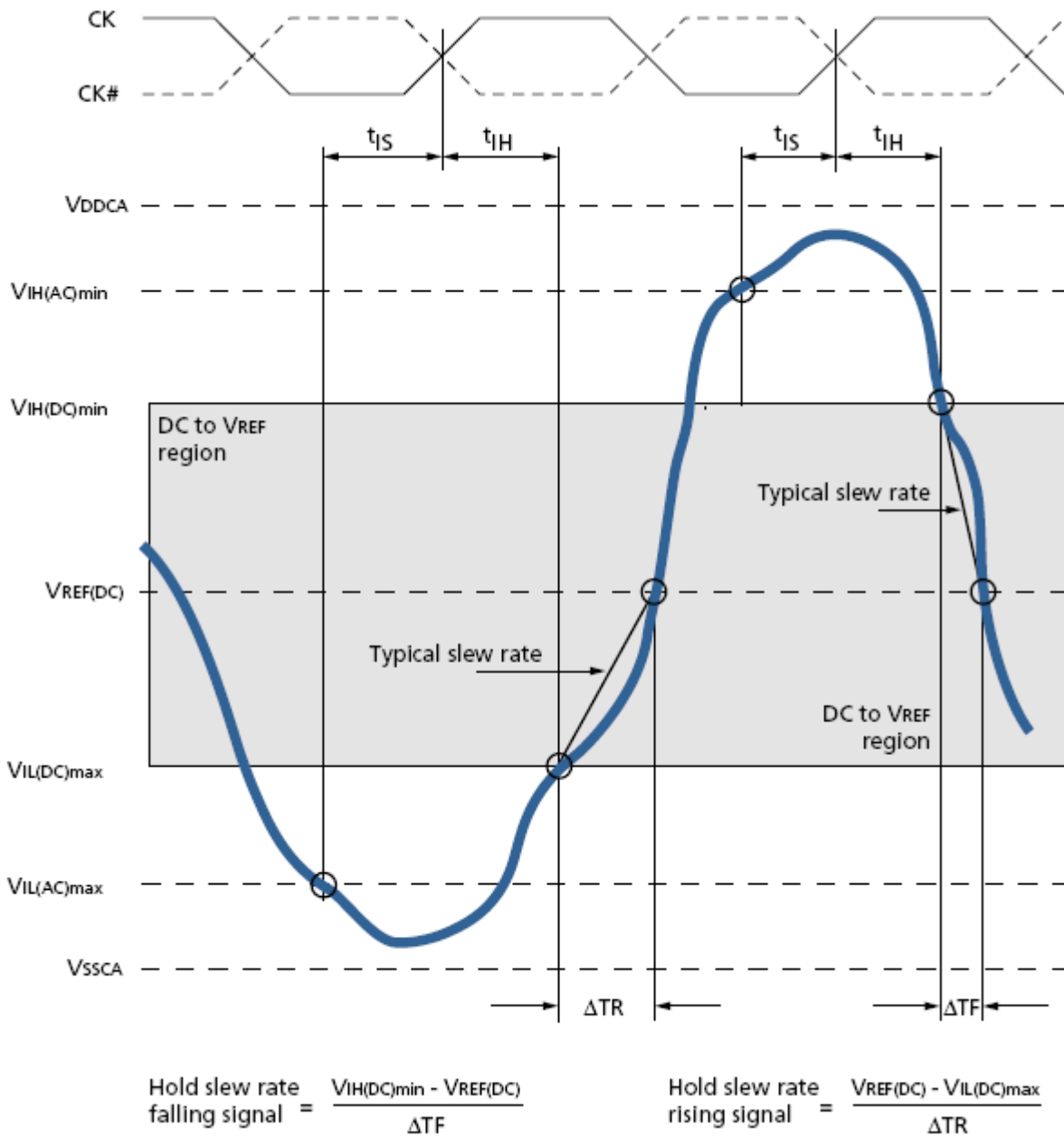

Typical Slew Rate: tIH for CA and \overline{CS} Relative to Clock

CA and \overline{CS} Setup, Hold, and Derating (Continued)

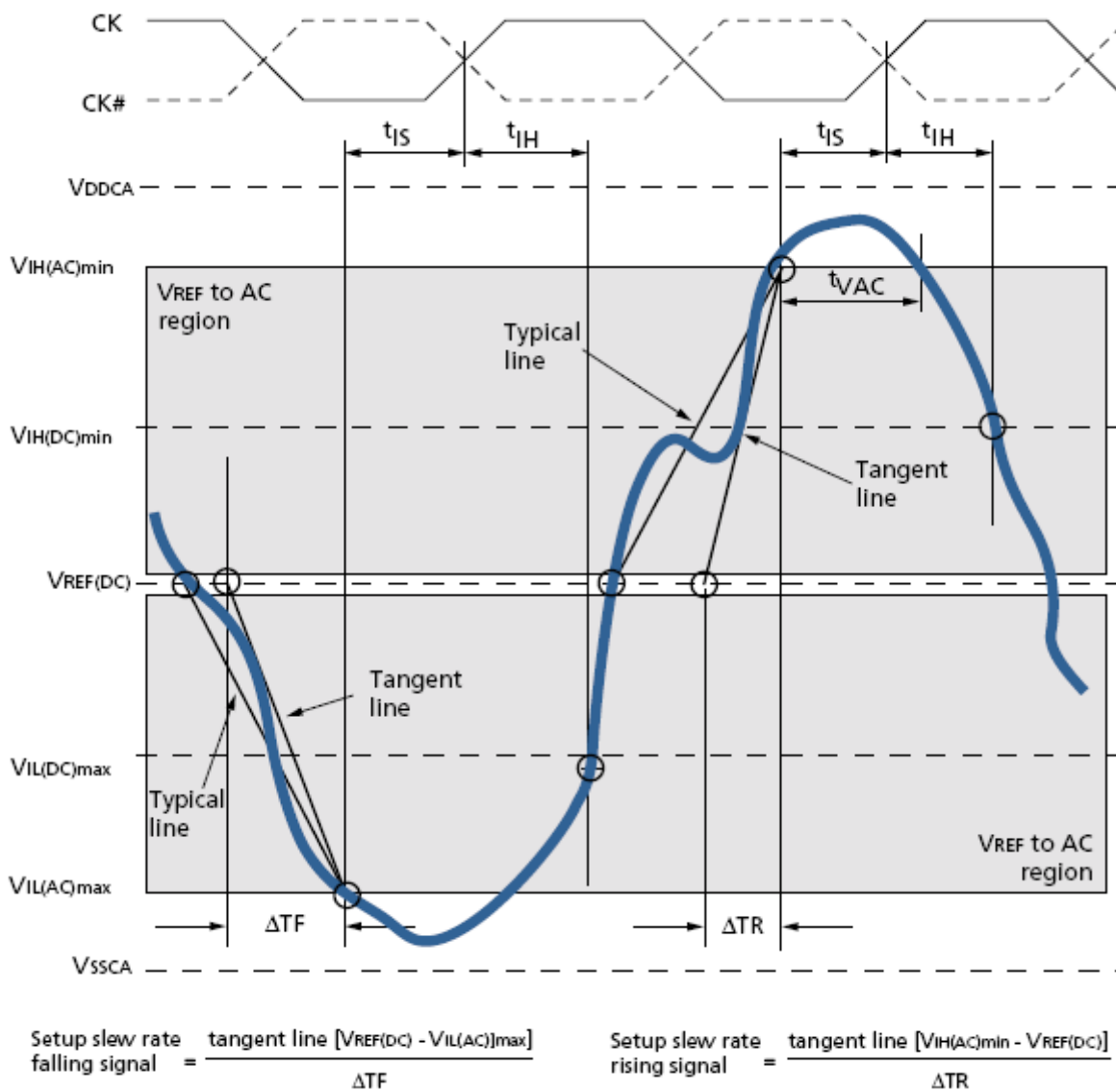

Tangent Line: t_{IS} for CA and \overline{CS} Relative to Clock

CA and \overline{CS} Setup, Hold, and Derating (Continued)

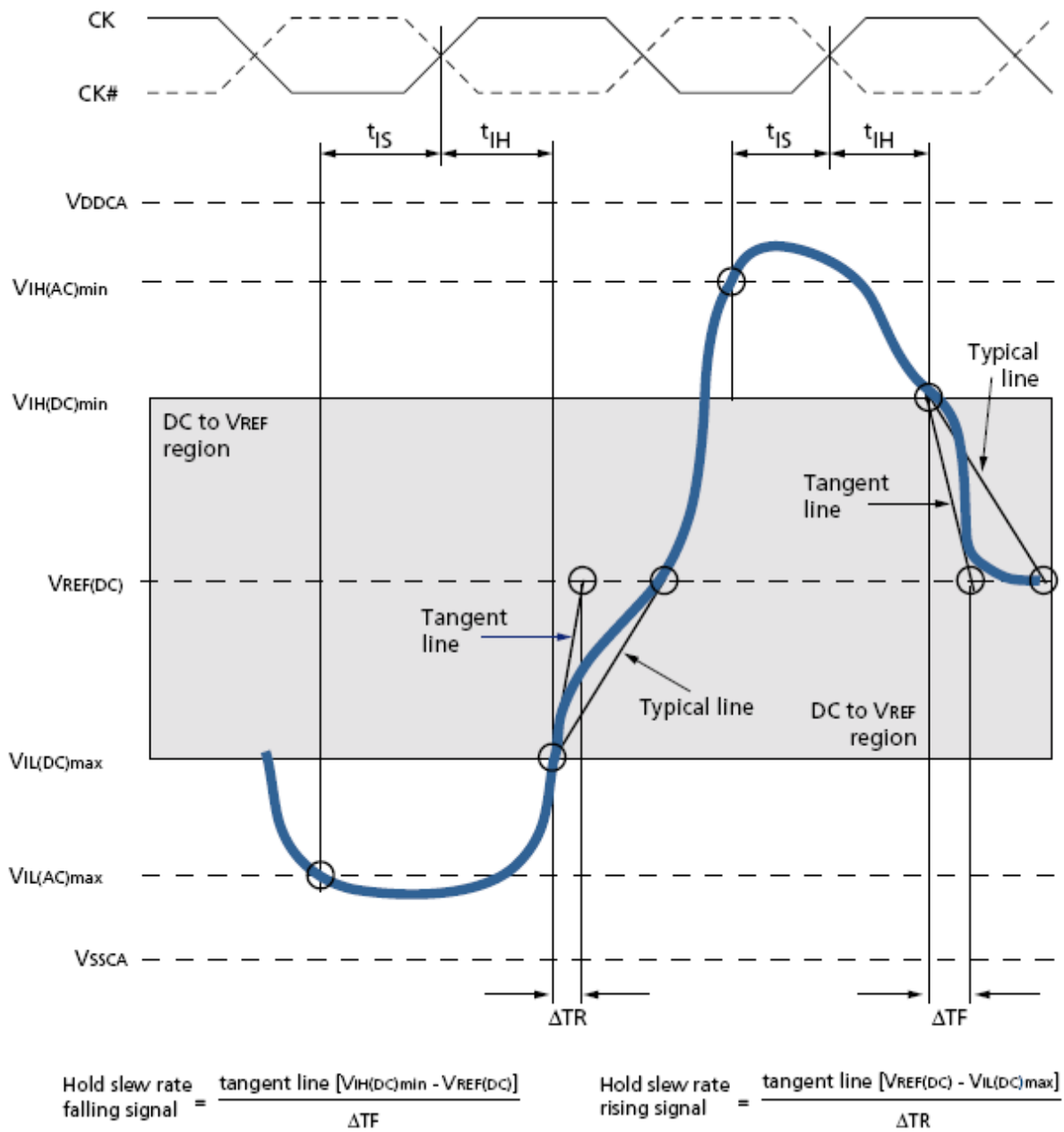

Tangent Line: tIH for CA and \overline{CS} Relative to Clock

Data Setup, Hold, and Slew Rate Derating

For all input signals (DQ, DM) calculate the total required setup time (tDS) and hold time (tDH) by adding the data sheet tDS(base) and tDH(base) values to the Δt_{DS} and Δt_{DH} derating values, respectively. Example: $t_{DS} = t_{DS}(\text{base}) + \Delta t_{DS}$.

The typical tDS slew rate for a rising signal is defined as the slew rate between the last crossing of VREF(DC) and the first crossing of VIH(AC)min. The typical tDS slew rate for a falling signal is defined as the slew rate between the last crossing of VREF(DC) and the first crossing of VIL(AC)max.

If the actual signal is consistently earlier than the typical slew rate, the area shaded gray between the VREF(DC) region and the AC region, use the typical slew rate for the derating value. If the actual signal is later than the typical slew rate line anywhere between the shaded VREF(DC) region and the AC region, the slew rate of a tangent line to the actual signal from the AC level to the DC level is used for the derating value.

The typical tDH slew rate for a rising signal is defined as the slew rate between the last crossing of VIL(DC)max and the first crossing of VREF(DC). The typical tDH slew rate for a falling signal is defined as the slew rate between the last crossing of VIH(DC)min and the first crossing of VREF(DC).

If the actual signal is consistently later than the typical slew rate line between the shaded DC-level-to-VREF(DC) region, use the typical slew rate for the derating value. If the actual signal is earlier than the typical slew rate line anywhere between shaded DC-to-VREF(DC) region, the slew rate of a tangent line to the actual signal from the DC level to VREF(DC) level is used for the derating value.

For a valid transition, the input signal must remain above or below VIH/VIL(AC) for the specified time, tVAC. The total setup time for slow slew rates could be negative (that is, a valid input signal may not have reached VIH/VIL(AC) at the time of the rising clock transition). A valid input signal is still required to complete the transition and reach VIH/VIL(AC).

For slew rates between the values listed in derating Tables, the derating values can be obtained using linear interpolation. Slew rate values are not typically subject to production testing. They are verified by design and characterization.

Data Setup and Hold Base Values (>400 MHz, 1 V/ns slew rate)

Parameter	Data Rate				Reference
	1066	800	667	533	
tDS (base)	-10	50	130	210	VIH/VIL(AC) = VREF(DC) ± 220mV
tDH (base)	80	140	220	300	VIH/VIL(DC) = VREF(DC) ± 130mV

Notes: AC/DC referenced for 1 V/ns DQ, DM slew rate, and 2 V/ns differential DQS, \overline{DQS} slew rate.

Data Setup, Hold, and Slew Rate Derating (Continued)

Derating Values for AC/DC-based tDS/tDH (AC220) - Δt_{DS} , Δt_{DH} derating in [ps], AC/DC-based

		DQS, DQS# Differential Slew Rate															
		4.0 V/ns		3.0 V/ns		2.0 V/ns		1.8 V/ns		1.6 V/ns		1.4 V/ns		1.2 V/ns		1.0 V/ns	
		Δt_{DS}	Δt_{DH}	Δt_{DS}	Δt_{DH}	Δt_{DS}	Δt_{DH}	Δt_{DS}	Δt_{DH}	Δt_{DS}	Δt_{DH}	Δt_{DS}	Δt_{DH}	Δt_{DS}	Δt_{DH}	Δt_{DS}	Δt_{DH}
DQ, DM slew rate V/ns	2.0	110	65	110	65	110	65										
	1.5	74	43	73	43	73	43	89	59								
	1.0	0	0	0	0	0	0	16	16	32	32						
	0.9			-3	-5	-3	-5	13	11	29	27	45	43				
	0.8					-8	-13	8	3	24	19	40	35	56	55		
	0.7							2	-6	18	10	34	26	50	46	66	78
	0.6									10	-3	26	13	42	33	58	65
	0.5											4	-4	20	16	36	48
	0.4													-7	2	17	34

Notes: Cell contents shaded in green are defined as "not supported."

Derating Values for AC/DC-based tDS/tDH (AC300) - Δt_{DS} , Δt_{DH} derating in [ps], AC/DC-based

		DQS, DQS# Differential Slew Rate															
		4.0 V/ns		3.0 V/ns		2.0 V/ns		1.8 V/ns		1.6 V/ns		1.4 V/ns		1.2 V/ns		1.0 V/ns	
		Δt_{DS}	Δt_{DH}	Δt_{DS}	Δt_{DH}	Δt_{DS}	Δt_{DH}	Δt_{DS}	Δt_{DH}	Δt_{DS}	Δt_{DH}	Δt_{DS}	Δt_{DH}	Δt_{DS}	Δt_{DH}	Δt_{DS}	Δt_{DH}
DQ, DM slew rate V/ns	2.0	150	100	150	100	150	100										
	1.5	100	67	100	67	100	67	116	83								
	1.0	0	0	0	0	0	0	16	16	32	32						
	0.9			-4	-8	-4	-8	12	8	28	24	44	40				
	0.8					-12	-20	4	-4	20	12	36	28	52	48		
	0.7							-3	-18	13	-2	29	14	45	34	61	66
	0.6									2	-21	18	-5	34	15	50	47
	0.5											-12	-32	4	-12	20	20
	0.4													-35	-40	-11	-8

Notes: Cell contents shaded in green are defined as "not supported."

Required tVAC Above VIH(AC) or Below VIL(AC) for Valid Transition

Slew Rate (V/ns)	tVAC at 300mV (ps)		tVAC at 220mV (ps)	
	Min	Max	Min	Max
>2.0	75	-	175	-
2	57	-	170	-
1.5	50	-	167	-
1	38	-	163	-
0.9	34	-	162	-
0.8	29	-	161	-
0.7	22	-	159	-
0.6	13	-	155	-
0.5	0	-	150	-
<0.5	0	-	150	-

Data Setup, Hold, and Slew Rate Derating (Continued)

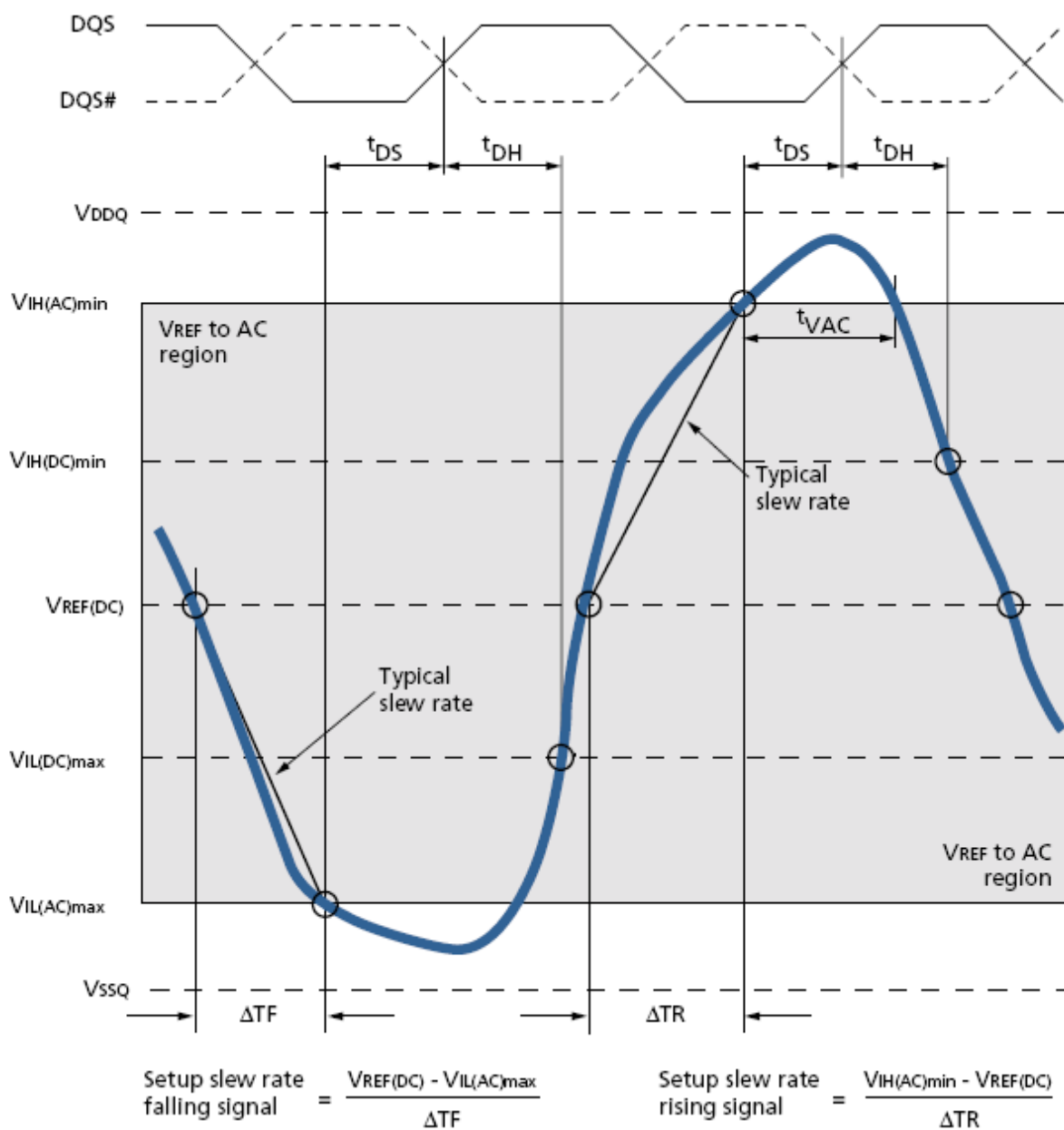

Typical Slew Rate and t_{VAC} : t_{DS} for DQ Relative to Strobe

Data Setup, Hold, and Slew Rate Derating (Continued)

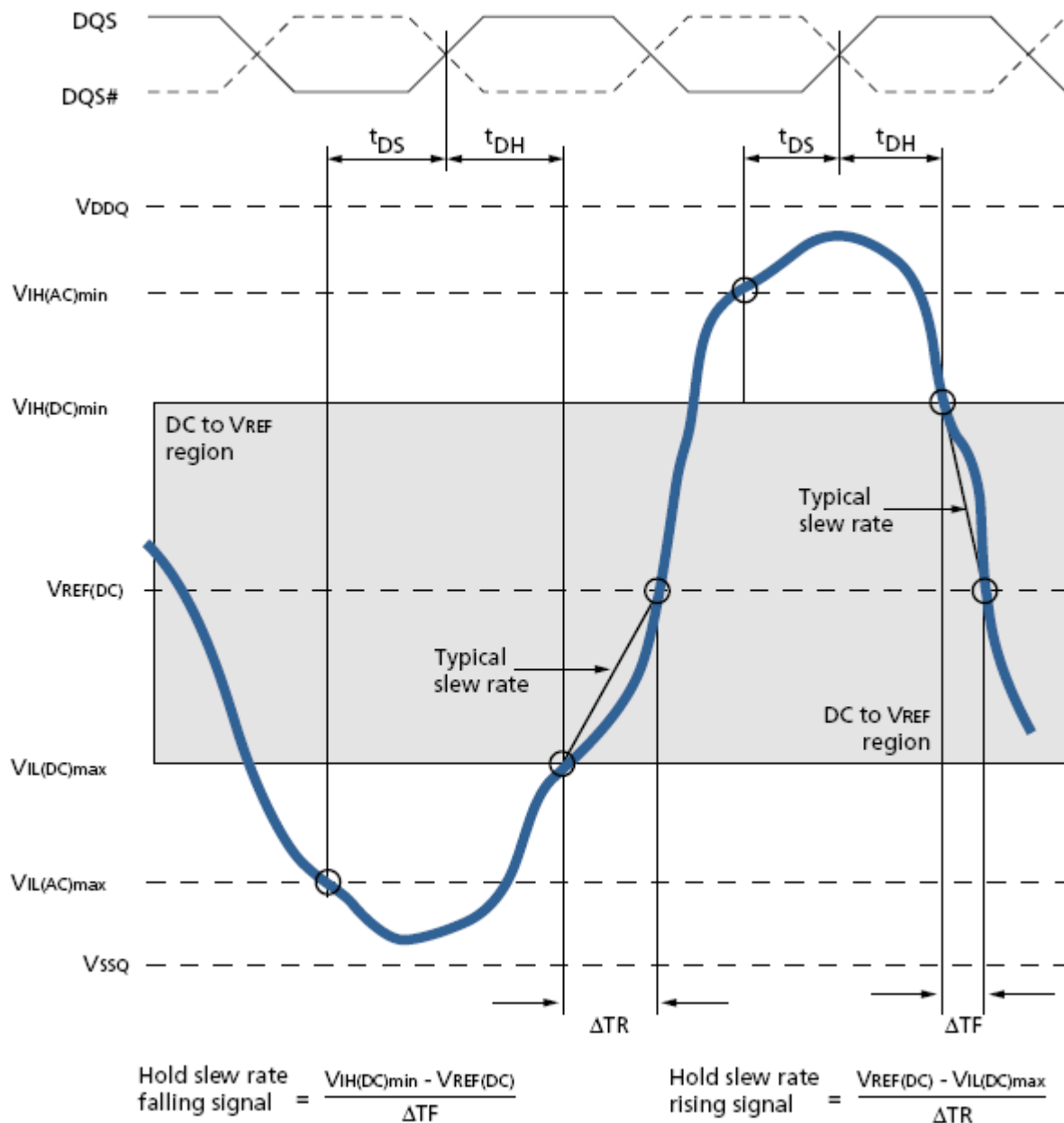

Typical Slew Rate: t_{DH} for DQ Relative to Strobe

Data Setup, Hold, and Slew Rate Derating (Continued)

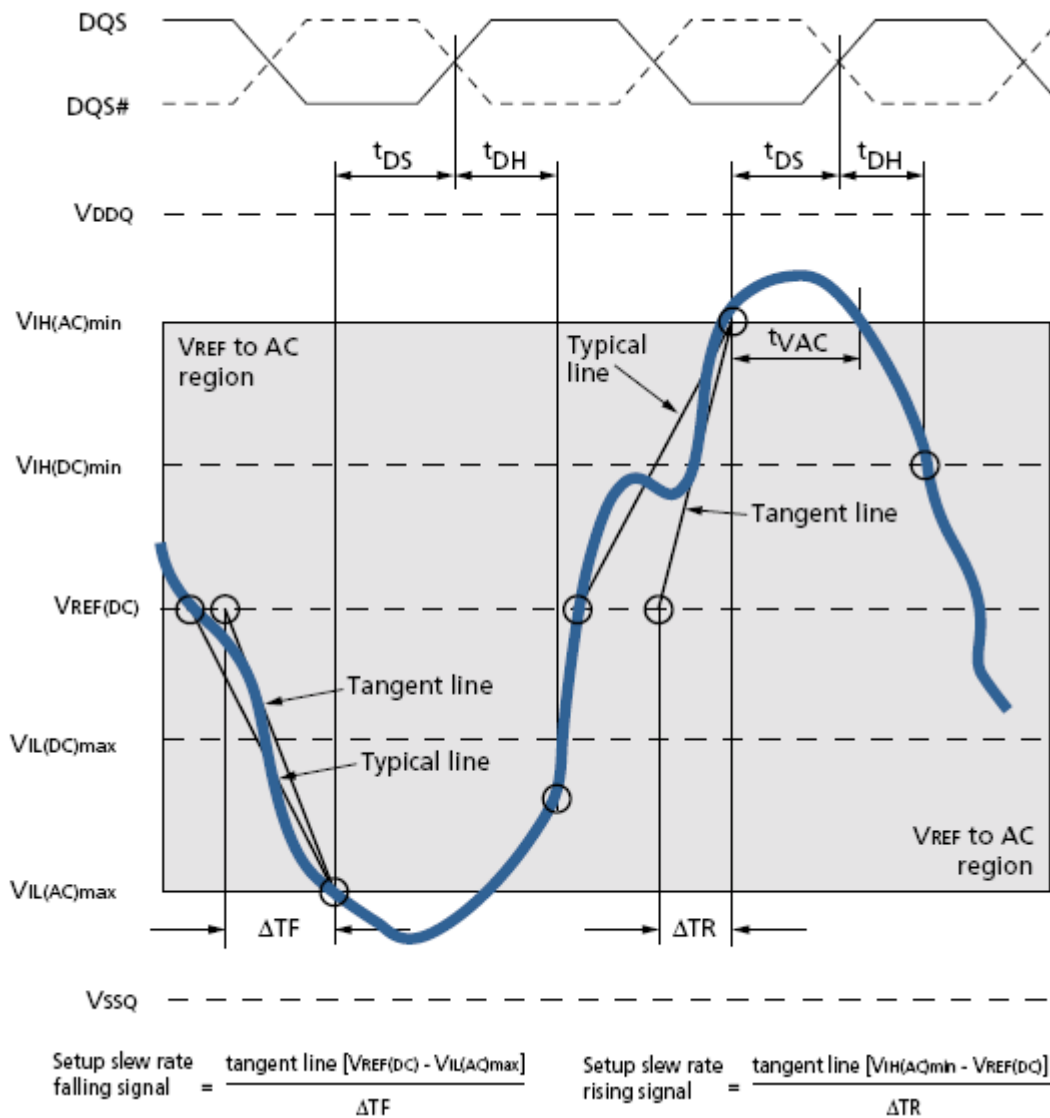

Tangent Line: t_{DS} for DQ with Respect to Strobe

Data Setup, Hold, and Slew Rate Derating (Continued)

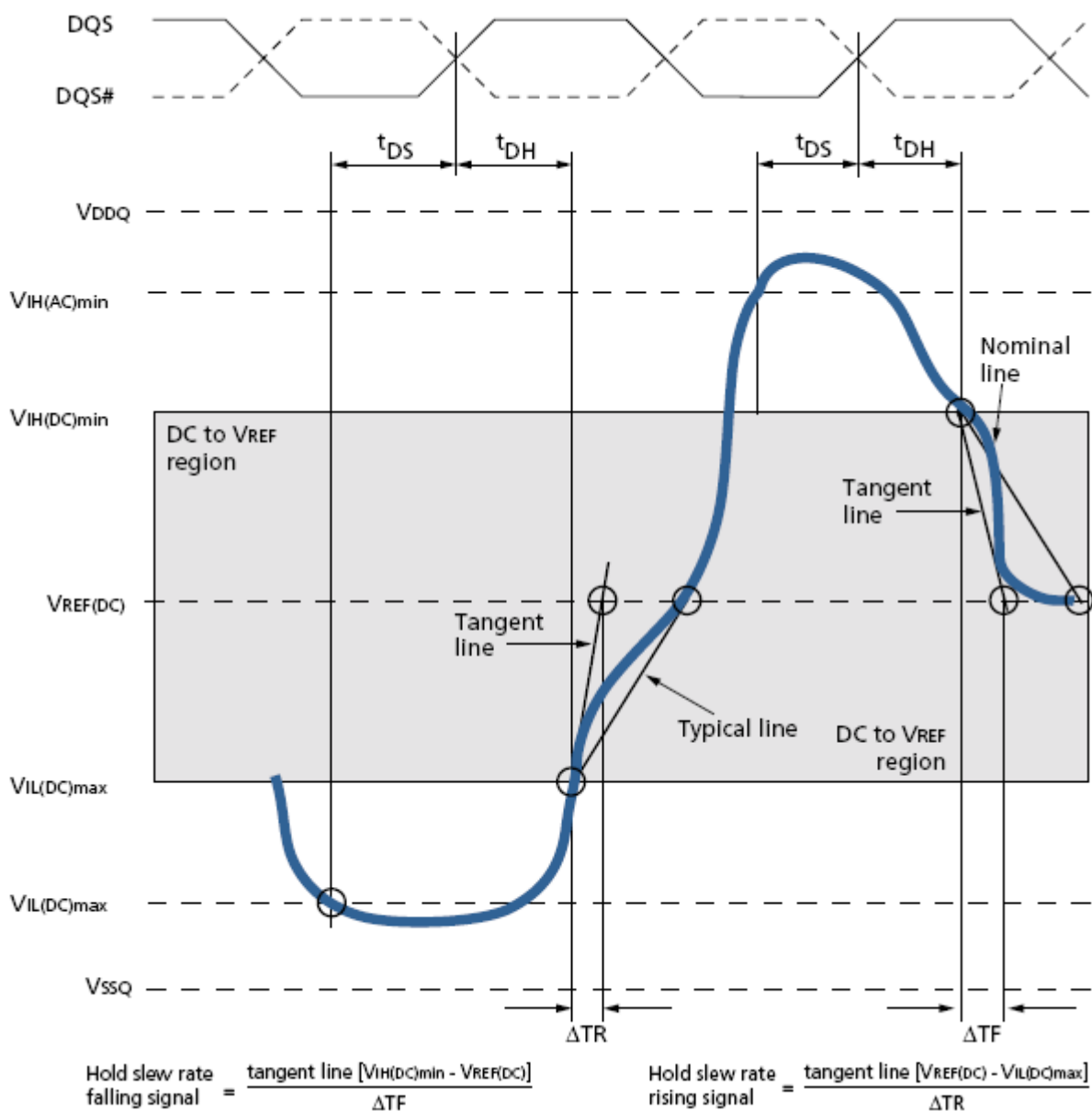

Tangent Line: t_{DH} for DQ with Respect to Strobe

Basic Functionality

LPDDR2-S4 uses the double data rate architecture on the Command/Address (CA) bus to reduce the number of input pins in the system. The 10-bit CA bus contains command, address, and Bank/Row Buffer information. Each command uses one clock cycle, during which command information is transferred on both the positive and negative edge of the clock.

To achieve high-speed operation, our LPDDR2-S4 SDRAM uses the double data rate architecture and adopt 4n-prefetch interface designed to transfer two data per clock cycle at the I/O pins. A single read or write access for the LPDDR2-S4 effectively consists of a single 4n-bit wide, one clock cycle data transfer at the internal SDRAM core and four corresponding n-bit wide, one-half-clock-cycle data transfer at the I/O pins. Read and write accesses to the LPDDR2-S4 are burst oriented; accesses start at a selected location and continue for a programmed number of locations in a programmed sequence.

For LPDDR2-S4 devices, accesses begin with the registration of an Active command, which is then followed by a Read or Write command. The address and BA bits registered coincident with the Active command are used to select the row and the Bank to be accessed. The address bits registered coincident with the Read or Write command are used to select the Bank and the starting column location for the burst access.

An auto precharge function may be enabled to provide a self-timed row precharge that is initiated at the end of the burst access. As with standard DDR SDRAMs, the pipelined, multibank architecture of the LPDDR2-S4 SDRAMs supports concurrent operation, thereby providing high effective bandwidth by hiding row precharge and activation time.

An auto refresh mode is provided, along with a power saving power-down mode. Deep power-down mode is offered to achieve maximum power reduction by eliminating the power of the memory array. Data will not be retained after device enters deep power-down mode. Two self refresh features, temperature-compensated self refresh (TCSR) and partial array self refresh (PASR), offer additional power saving. TCSR is controlled by the automatic on-chip temperature sensor. The PASR can be customized using the extended mode register settings. The two features may be combined to achieve even greater power saving. The DLL that is typically used on standard DDR devices is not necessary on the LPDDR2-S4 SDRAM. It has been omitted to save power.

Prior to normal operation, the LPDDR2-S4 SDRAM must be initialized. The following sections provide detailed information covering device initialization, register definition, command descriptions and device operation.

Power-Up, Initialization, and Power-Off

LPDDR2 devices must be powered up and initialized in a predefined manner. Power-up and initialization by means other than those specified will result in undefined operation.

Voltage Ramp and Device Initialization

The following sequence must be used to power up the device. Unless specified otherwise, this procedure is mandatory and applies to devices.

1) Voltage Ramp:

While applying power (after T_a), CKE must be held LOW ($\leq 0.2 \times V_{DDCA}$), and all other inputs must be between V_{ILmin} and V_{IHmax} . The device outputs remain at High-Z while CKE is held LOW. Following the completion of the voltage ramp (T_b), CKE must be maintained LOW. DQ, DM, DQS and DQS# voltage levels must be between V_{SSQ} and V_{DDQ} during voltage ramp to avoid latch up. CK, \overline{CK} , \overline{CS} , and CA input levels must be between V_{SSCA} and V_{DDCA} during voltage ramp to avoid latch-up. Voltage ramp power supply requirements are provided bellow.

Voltage Ramp Conditions

After...	Applicable Conditions
Ta is reached	V_{DD1} must be greater than V_{DD2} —200mV
	V_{DD11} and V_{DD2} must be greater than V_{DDCA} —200mV
	V_{DD1} and V_{DD2} must be greater than V_{DDQ} —200mV
	V_{REF} must always be less than all other supply voltages

Notes:

1. T_a is the point when any power supply first reaches 300mV.
2. Noted conditions apply between T_a and power-down (controlled or uncontrolled).
3. T_b is the point at which all supply and reference voltages are within their defined operating ranges. Reference voltages shall be within their respective min/max operating conditions a minimum of 5 clocks before CKE goes high.
4. Power ramp duration t_{INIT0} ($T_b - T_a$) must not exceed 20ms.
5. For supply and reference voltage operating conditions, see DC power table on page 12.
6. The voltage difference between any of VSS, VSSQ, and VSSCA pins must not exceed 100mV.

Beginning at T_b , CKE must remain LOW for at least $t_{INIT1} = 100$ ns, after which CKE can be asserted HIGH. The clock must be stable at least $t_{INIT2} = 5 \times t_{CK}$ prior to the first CKE LOW-to-HIGH transition (T_c). CKE, \overline{CS} , and CA inputs must observe setup and hold requirements (t_{IS} , t_{IH}) with respect to the first rising clock edge (as well as to subsequent falling and rising edges).

If any MRRs are issued, the clock period must be within the range defined for t_{CKb} (18ns to 100ns). MRWs can be issued at normal clock frequencies as long as all AC timings are met. Some AC parameters (for example, t_{DQSCK}) could have relaxed timings (such as t_{DQSCKb}) before the system is appropriately configured. While keeping CKE HIGH, NOP commands must be issued for at least $t_{INIT3} = 200\mu s$ (T_d).

2) RESET Command:

After t_{INIT3} is satisfied, the MRW RESET command must be issued (T_d). An optional PRECHARGE ALL command can be issued prior to the MRW RESET command. Wait at least $t_{INIT4}=1\mu s$ while keeping CKE asserted and issuing NOP commands.

3) MRRs and Device Auto Initialization (DAI) Polling:

After t_{INIT4} is satisfied (T_e), only MRR commands and power-down entry/exit commands are supported.

After T_e , CKE can go LOW in alignment with power-down entry and exit specifications. Use the MRR command to poll the DAI bit and report when device auto initialization is complete; otherwise, the controller must wait a minimum of t_{INIT5} , or until the DAI bit is set before proceeding. As the memory output buffers are not properly configured by T_e , some AC parameters must have relaxed timings before the system is appropriately configured. After the DAI bit (MR0, DAI) is set to zero by the memory device (DAI complete), the device is in the idle state (T_f). DAI status can be determined by issuing the MRR command to MR0. The device sets the DAI bit no later than t_{INIT5} after the RESET command. The controller must wait at least t_{INIT5} or until the DAI bit is set before proceeding.

4) ZQ Calibration:

After t_{INIT5} (T_f), the MRW initialization calibration (ZQ_CAL) command can be issued to the memory (MR10). For LPDDR2 devices that do not support ZQ calibration, this command will be ignored. This command is used to calibrate output impedance over process, voltage, and temperature. In systems where more than one LPDDR2 device exists on the same bus, the controller must not overlap MRW ZQ_CAL commands. The device is ready for normal operation after t_{ZQINIT} .

5) Normal Operation:

After t_{ZQINIT} (T_g), MRW commands must be used to properly configure the memory (for example the output buffer drive strength, latencies, etc.). Specifically, MR1, MR2, and MR3 must be set to configure the memory for the target frequency and memory configuration. After the initialization sequence is complete, the device is ready for any valid command. After T_g , the clock frequency can be changed using the procedure described in “Input Clock Frequency Changes and Clock Stop Events”.

Power Ramp and Initialization Sequence

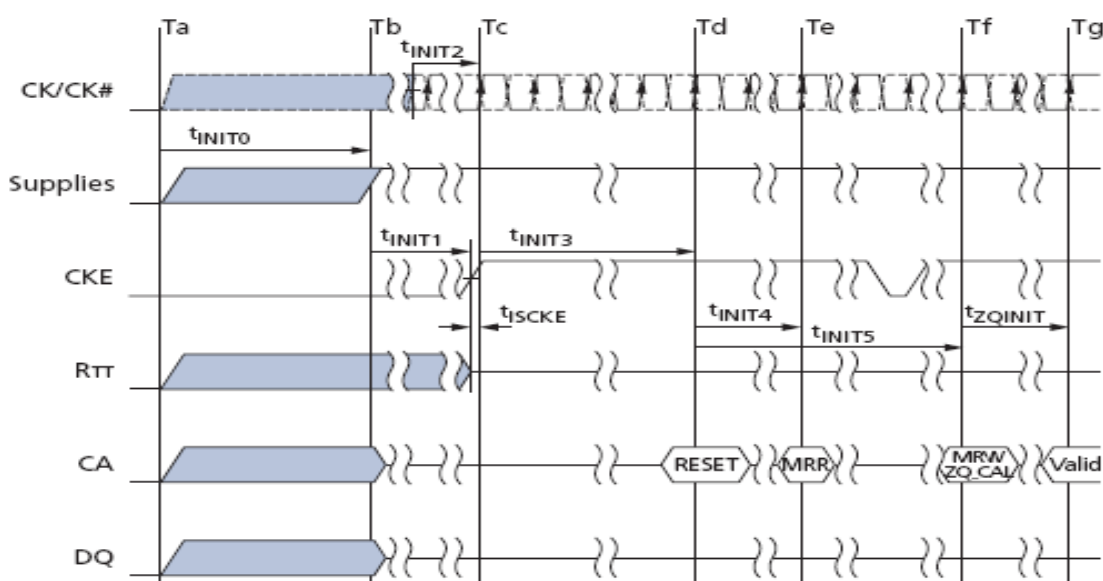

Notes: 1. High-Z on the CA bus indicates valid NOP. 2. For t_{INIT} values, see below.

Initialization Timing Parameters

Symbol	Parameter	Value		Unit
		min	max	
t_{INIT0}	Maximum Power Ramp Time	-	20	ms
t_{INIT1}	Minimum CKE low time after completion of power ramp	100	-	ns
t_{INIT2}	Minimum stable clock before first CKE high	5	-	t_{CK}
t_{INIT3}	Minimum idle time after first CKE assertion	200	-	us
t_{INIT4}	Minimum idle time after Reset command, this time will be about $2 \times t_{RFCab} + t_{RPab}$	1	-	us
t_{INIT5}	Maximum duration of Device Auto-Initialization	-	10	us
t_{ZQINIT}	ZQ Initial Calibration	1	-	us
t_{CKb}	Clock cycle time during boot	18	100	ns

Initialization after RESET (without voltage ramp):

If the RESET command is issued before or after the power-up initialization sequence, the re-initialization procedure must begin at T_d .

Power-Off Sequence

Use the following sequence to power off the device. Unless specified otherwise, this procedure is mandatory and applies to devices. While powering off, CKE must be held LOW ($\leq 0.2 \times V_{DDCA}$); all other inputs must be between V_{ILmin} and V_{IHmax} . The device outputs remain at High-Z while CKE is held LOW.

\overline{DQ} , \overline{DM} , \overline{DQS} , and \overline{DQS} voltage levels must be between V_{SSQ} and V_{DDQ} during the power-off sequence to avoid latch-up. \overline{CK} , \overline{CS} , and \overline{CA} input levels must be between V_{SSCA} and V_{DDCA} during the power-off sequence to avoid latch-up.

T_x is the point where any power supply drops below the minimum value.

T_z is the point where all power supplies are below 300mV. After T_z , the device is powered off.

Power Supply Conditions

Between...	Applicable Conditions
T_x and T_z	V_{DD1} must be greater than V_{DD2} —200mV
T_x and T_z	V_{DD1} must be greater than V_{DDCA} —200mV
T_x and T_z	V_{DD1} must be greater than V_{DDQ} —200mV
T_x and T_z	V_{REF} must always be less than all other supply voltages

Notes: The voltage difference between any of V_{SS} , V_{SSQ} , and V_{SSCA} pins must not exceed 100mV.

Uncontrolled Power-Off Sequence

When an uncontrolled power-off occurs, the following conditions must be met:

At Tx, when the power supply drops below the minimum values specified, all power supplies must be turned off and all power-supply current capacity must be at zero, except for any static charge remaining in the system.

After Tz (the point at which all power supplies first reach 300mV), the device must power off. The time between Tx and Tz must not exceed 2s. During this period, the relative voltage between power supplies is uncontrolled. VDD1 and VDD2 must decrease with a slope lower than 0.5 V/ μ s between Tx and Tz. An uncontrolled power-off sequence can occur a maximum of 400 times over the life of the device.

Power-Off Timing

Symbol	Parameter	Min	Max	Unit
tPOFF	Maximum power-off ramp time	-	2	s

Mode Register Definition

LPDDR2 devices contain a set of mode registers used for programming device operating parameters, reading device information and status, and for initiating special operations such as DQ calibration, ZQ calibration, and device reset.

Mode Register Assignment and Definition

Table below shows the mode registers for LPDDR2 SDRAM. Each register is denoted as “R”, if it can be read but not written, “W” if it can be written but not read, and “R/W” if it can be read and written. Mode Register Read Command shall be used to read a register. Mode Register Write Command shall be used to write a register.

Mode Register Assignment in LPDDR2 SDRAM/NVM (Common part)											
MR#	MA <7:0>	Function	Access	OP7	OP6	OP5	OP4	OP3	OP2	OP1	OP0
0	00 _H	Device Info.	R	(RFU)						DI	DAI
1	01 _H	Device Feature1	W	nWR (for AP)			WC	BT	BL		
2	02 _H	Device Feature2	W	(RFU)				RL & WL			
3	03 _H	I/O Config-1	W	(RFU)				DS			
4	04 _H	Refresh Rate	R	TUF	(RFU)			Refresh Rate			
5	05 _H	Basic Config-1	R	LPDDR2 Manufacturer ID							
6	06 _H	Basic Config-2	R	Revision ID1							
7	07 _H	Basic Config-3	R	Revision ID2							
8	08 _H	Basic Config-4	R	I/O width		Density				Type	
9	09 _H	Test Mode	W	Vendor-Specific Test Mode							
10	0A _H	IO Calibration	W	Calibration Code							
11~15	0B _H ~0F _H	(reserved)		(RFU)							

Mode Register Assignment in LPDDR2 SDRAM/NVM (SDRAM part)											
MR#	MA <7:0>	Function	Access	OP7	OP6	OP5	OP4	OP3	OP2	OP1	OP0
16	10 _H	PASR_BANK	W	Bank Mask							
17	11 _H	PASR_Seg	W	Segment Mask							
18-19	12 _H -13 _H	(Reserved)		(RFU)							

Mode Register Assignment in LPDDR2 SDRAM/NVM (NVM part)											
MR#	MA <7:0>	Function	Access	OP7	OP6	OP5	OP4	OP3	OP2	OP1	OP0
20-31	18 _H -1F _H	Reserved for NVM									
Mode Register Assignment in LPDDR2 SDRAM/NVM (Reset Command & RFU part)											
MR#	MA <7:0>	Function	Access	OP7	OP6	OP5	OP4	OP3	OP2	OP1	OP0
32	20 _H	DQ calibration pattern A	R	See "Data Calibration Pattern Description"							
33-39	21 _H -27 _H	(Do Not Use)									
40	28 _H	DQ calibration pattern B	R	See "Data Calibration Pattern Description"							
41-47	29 _H -2F _H	(Do Not Use)									
48-62	30 _H -3E _H	(Reserved)									(RFU)
63	3F _H	Reset	W								X
64-126	40 _H -7E _H	(Reserved)									(RFU)
127	7F _H	(Do Not Use)									
128-190	80 _H -BE _H	(Reserved for Vendor Use)									(RFU)
191	BF _H	(Do Not Use)									
192-254	C0 _H -FE _H	(Reserved for Vendor Use)									(RFU)
255	FF _H	(Do Not Use)									

Notes:

1. RFU bits shall be set to "0" during Mode Register writes.
2. RFU bits shall be read as "0" during Mode Register reads.
3. All Mode Registers from that are specified as RFU or write-only shall return undefined data when read and DQS shall be toggled.
4. All Mode Registers that are specified as RFU shall not be written.
5. Writes to read-only registers shall have no impact on the functionality of the device.

MR0_Devcie Information (MA<7:0> = 00 _H):								
OP7	OP6	OP5	OP4	OP3	OP2	OP1	OP0	
(RFU)						DI	DAI	
OP1	DI (Device Information)				Read-only		0 _B : S2 or S4 SDRAM 1 _B : Do Not Use	
OP0	DAI (Device Auto-Initialization Status)				Read-only		0 _B : DAI complete 1 _B : DAI still in progress	

MR1_Devcie Feature 1 (MA<7:0> = 01 _H):								
OP7	OP6	OP5	OP4	OP3	OP2	OP1	OP0	
nWR (for AP)		WC	BT	BL				
OP<2:0>	BL (Burst Length)				Write-only		010 _B : BL4 (default) 011 _B : BL8 100 _B : BL16 All others: reserved	
OP3	BT ¹ (Burst Type)				Write-only		0 _B : Sequential (default) 1 _B : Interleaved	
OP4	WC (Wrap)				Write-only		0 _B : Wrap (default) 1 _B : No wrap (allowed for SDRAM BL4 only)	
OP<7:5>	nWR ²				Write-only		001 _B : nWR=3 (default) 010 _B : nWR=4 011 _B : nWR=5 100 _B : nWR=6 101 _B : nWR=7 110 _B : nWR=8 All others: reserved	

Notes:

1. BL16, interleaved is not an official combination to be supported.
2. Programmed value in nWR register is the number of clock cycles which determines when to start internal precharge operation for a write burst with AP enabled. It is determined by $RU(t_{WR}^t/CK)$.

Burst Sequence by BL, BT, and WC																								
C3	C2	C1	C0	WC	BT	BL	Burst Cycle Number and Burst Address Sequence																	
							1	2	3	4	5	6	7	8	9	10	11	12	13	14	15	16		
x	x	0 _B	0 _B	wrap	any	4	0	1	2	3														
x	x	1 _B	0 _B				2	3	0	1														
x	x	x	0 _B	nw	any		y	y+1	y+2	y+3														
C3	C2	C1	C0	WC	BT	BL	Burst Cycle Number and Burst Address Sequence																	
							1	2	3	4	5	6	7	8	9	10	11	12	13	14	15	16		
x	0 _B	0 _B	0 _B	wrap	seq	8	0	1	2	3	4	5	6	7										
x	0 _B	1 _B	0 _B				2	3	4	5	6	7	0	1										
x	1 _B	0 _B	0 _B				4	5	6	7	0	1	2	3										
x	1 _B	1 _B	0 _B				6	7	0	1	2	3	4	5										
x	0 _B	0 _B	0 _B		int		0	1	2	3	4	5	6	7										
x	0 _B	1 _B	0 _B				2	3	0	1	6	7	4	5										
x	1 _B	0 _B	0 _B				4	5	6	7	0	1	2	3										
x	1 _B	1 _B	0 _B				6	7	4	5	2	3	0	1										
x	x	x	0 _B	nw	any	illegal (not allowed)																		
0 _B	0 _B	0 _B	0 _B	wrap	seq	16	0	1	2	3	4	5	6	7	8	9	A	B	C	D	E	F		
0 _B	0 _B	1 _B	0 _B				2	3	4	5	6	7	8	9	A	B	C	D	E	F	0	1		
0 _B	1 _B	0 _B	0 _B				4	5	6	7	8	9	A	B	C	D	E	F	0	1	2	3	4	5
0 _B	1 _B	1 _B	0 _B				6	7	8	9	A	B	C	D	E	F	0	1	2	3	4	5	6	7
1 _B	0 _B	0 _B	0 _B		8		9	A	B	C	D	E	F	0	1	2	3	4	5	6	7	8	9	
1 _B	0 _B	1 _B	0 _B		A		B	C	D	E	F	0	1	2	3	4	5	6	7	8	9	A	B	
1 _B	1 _B	0 _B	0 _B		C		D	E	F	0	1	2	3	4	5	6	7	8	9	A	B			
1 _B	1 _B	1 _B	0 _B		E		F	0	1	2	3	4	5	6	7	8	9	A	B	C	D			
x	x	x	0 _B		int	illegal (not allowed)																		
x	x	x	0 _B	nw	any	illegal (not allowed)																		

- Notes:
1. C0 input is not present on CA bus. It is implied zero.
 2. For BL=4, the burst address represents C1~C0.
 3. For BL=8, the burst address represents C2~C0.
 4. For BL=16, the burst address represents C3~C0.
 5. For no-wrap, BL4, the burst must not cross the page boundary or the sub-page boundary. The variable y can start at any address with C0 equal to 0, but must not start at any address shown below.

Non-Wrap Restrictions

Width	64Mb	128Mb/256Mb	512Mb/1Gb/2Gb	4Gb/8Gb
Cannot cross full page boundary				
X16	FE, FF, 00, 01	1FE, 1FF, 000, 001	3FE, 3FF, 000, 001	7FE, 7FF, 000, 001
X32	7E, 7F, 00, 01	FE, FF, 00, 01	1FE, 1FF, 000, 001	3FE, 3FF, 000, 001
Cannot cross sub-page boundary				
X16	7E, 7F, 80, 81	0FE, 0FF, 100, 101	1FE, 1FF, 200, 201	3FE, 3FF, 400, 401
X32	none	none	None	none

Notes: Non-wrap BL= 4 data orders shown are prohibited.

MR2_Devcie Feature 2 (MA<7:0> = 02 _H):							
OP7	OP6	OP5	OP4	OP3	OP2	OP1	OP0
(RFU)			RL & WL				
OP<3:0>		RL & WL (Read Latency & Write Latency)			Write-only		0001 _B : RL3 / WL1 (default) 0010 _B : RL4 / WL2 0011 _B : RL5 / WL2 0100 _B : RL6 / WL3 0101 _B : RL7 / WL4 0110 _B : RL8 / WL4 All others: reserved

MR3_I/O Configuration 1 (MA<7:0> = 03 _H):							
OP7	OP6	OP5	OP4	OP3	OP2	OP1	OP0
(RFU)			DS				
OP<3:0>		DS (Drive Strength)			Write-only		0000 _B : reserved 0001 _B : 34.3 ohm typical 0010 _B : 40.0 ohm typical (default) 0011 _B : 48.0 ohm typical 0100 _B : 60.0 ohm typical 0101 _B : reserved 0110 _B : 80.0 ohm typical All others: reserved

MR4_Device Temperature (MA<7:0> = 04 _H):							
OP7	OP6	OP5	OP4	OP3	OP2	OP1	OP0
TUF	(RFU)			SDRAM Refresh Rate			
OP<2:0>	SDRAM Refresh Rate			Read-only			000 _B : 4 x t _{REFI} , SDRAM Low Temp. operating limit exceeded 001 _B : 4 x t _{REFI} , 4 x t _{REFIpb} , 4 x t _{REFW} 010 _B : 2 x t _{REFI} , 2 x t _{REFIpb} , 2 x t _{REFW} , 011 _B : 1 x t _{REFI} , 1 x t _{REFIpb} , 1 x t _{REFW} (<= 85C) 100 _B : RFU 101 _B : 0.25 x t _{REFI} , 0.25 x t _{REFIpb} , 0.25 x t _{REFW} , don't re-rate SDRAM AC timing 110 _B : 0.25 x t _{REFI} , 0.25 x t _{REFIpb} , 0.25 x t _{REFW} , derate SDRAM AC timing 111 _B : SDRAM High temperature operating limit exceeded
OP7	TUF (Temperature Update Flag)			Read-only			0 _B : OP<2:0> value has not changed since last read of MR4. 1 _B : OP<2:0> value has changed since last read of MR4.

Notes:

1. A Mode Register Read from MR4 will reset OP7 to "0".
2. OP7 is reset to "0" at power-up.
3. If OP2 equals "1", the device temperature is greater than 85C.
4. OP7 is set to "1", if OP2~OP0 has changed at any time since the last read of MR4.
5. LPDDR2 might not operate properly when OP<2:0> = 000_B or 111_B.
6. For specified operating temperature range and maximum operating temperature.
7. LPDDR2 devices must be derated by adding 1.875ns to the following core timing parameters: tRCD, tRC, tRAS, tRP, and tRRD. The tDQSK parameter must be derated .. Prevailing clock frequency specifications and related setup and hold timings remain unchanged.
8. The recommended frequency for reading MR4 is provided in "Temperature Sensor".

MR5_Basic Configuration 1 (MA<7:0> = 05 _H):								
OP7	OP6	OP5	OP4	OP3	OP2	OP1	OP0	
LPDDR2 Manufacturer ID								
OP<7:0>	Manufacturer ID				Read-only			0000 0000 _B : Reserved 0000 0001 _B : Samsung 0000 0010 _B : Qimonda 0000 0011 _B : Elpida 0000 0100 _B : Etron 0000 0101 _B : Nanya 0000 0110 _B : Hynix 0000 0111 _B : Mosel 0000 1000 _B : Winbond 0000 1001 _B : ESMT 0000 1010 _B : Reserved 0000 1011 _B : Spansion 0000 1100 _B : SST 0000 1101 _B : ZMOS 0000 1110 _B : Intel 1111 1110 _B : Numonyx 1111 1111 _B : Micron All Others : Reserved

MR6_Basic Configuration 2 (MA<7:0> = 06 _H):								
OP7	OP6	OP5	OP4	OP3	OP2	OP1	OP0	
Revision ID1								
OP<7:0>	Revision ID1				Read-only			00000000 _B : A-version

MR7_Basic Configuration 3 (MA<7:0> = 07 _H):								
OP7	OP6	OP5	OP4	OP3	OP2	OP1	OP0	
Revision ID2								
OP<7:0>	Revision ID2				Read-only			00000000 _B : A-version

MR8_Basic Configuration 4 (MA<7:0> = 08 _H):								
OP7	OP6	OP5	OP4	OP3	OP2	OP1	OP0	
I/O width		Density			Type			
OP<1:0>		Type			Read-only		00 _B : S4 SDRAM 01 _B : S2 SDRAM 10 _B : N NVM 11 _B : Reserved	
OP<5:2>		Density			Read-only		0000 _B : 64Mb 0001 _B : 128Mb 0010 _B : 256Mb 0011 _B : 512Mb 0100 _B : 1Gb 0101 _B : 2Gb 0110 _B : 4Gb 0111 _B : 8Gb 1000 _B : 16Gb 1001 _B : 32Gb All others: reserved	
OP<7:6>		I/O width			Read-only		00 _B : x32 01 _B : x16 10 _B : x8 11 _B : not used	

MR9_Test Mode (MA<7:0> = 09 _H):								
OP7	OP6	OP5	OP4	OP3	OP2	OP1	OP0	
Vendor-specific Test Mode								

MR10_Calibration (MA<7:0> = 0A _H):							
OP7	OP6	OP5	OP4	OP3	OP2	OP1	OP0
Calibration Code							
OP<7:0>		Calibration Code			Write-only		0xFF: Calibration command after initialization 0xAB: Long calibration 0x56: Short calibration 0xC3: ZQ Reset All others: Reserved

Notes:

- Host processor shall not write MR10 with "Reserved" values.
- LPDDR2 devices shall ignore calibration command, when a "Reserved" values is written into MR10.
- See AC timing table for the calibration latency.
- If ZQ is connected to VSSCA through RZQ, either the ZQ calibration function (see "MRW ZQ Calibration Command") or default calibration (through the ZQ RESET command) is supported. If ZQ is connected to VDDCA, the device operates with default calibration, and ZQ calibration commands are ignored. In both cases, the ZQ connection must not change after power is supplied to the device.
- Devices that do not support calibration ignore the ZQ calibration command.

MR11:15_(Reserved) (MA<7:0> = 0B _H - 0F _H):							
OP7	OP6	OP5	OP4	OP3	OP2	OP1	OP0
RFU							

MR16_PASR_Bank Mask (MA<7:0> = 010 _H):							
OP7	OP6	OP5	OP4	OP3	OP2	OP1	OP0
Bank Mask (4-Bank or 8-Bank)							
OP<7:0>		Bank Mask Code			Write-only		0 _B : refresh enable to the bank (=unmasked, default) 1 _B : refresh blocked (=masked)

OP	Bank Mask	4 Bank	8 Bank
0	XXXXXXXX1	Bank 0	Bank 0
1	XXXXXX1X	Bank 1	Bank 1
2	XXXXX1XX	Bank 2	Bank 2
3	XXXX1XXX	Bank 3	Bank 3

4	XXX1XXXX	-	Bank 4
5	XX1XXXXX	-	Bank 5
6	X1XXXXXX	-	Bank 6
7	1XXXXXXX	-	Bank 7

Notes: For 4-bank S4 SDRAM, only OP<3:0> are used.

MR17_PASR_Segment Mask (MA<7:0> = 011_H):							
OP7	OP6	OP5	OP4	OP3	OP2	OP1	OP0
Segment Mask							
OP<7:0>	Segment Mask Code			Write-only		0 _B : refresh enable to the bank (=unmasked, default) 1 _B : refresh blocked (=masked)	

Segment	OP	Bank Mask	1Gb	2Gb, 4Gb	8Gb
			R12:10	R13:11	R14:12
0	0	XXXXXXXX1	000 _B		
1	1	XXXXXXXX1X	001 _B		
2	2	XXXXX1XX	010 _B		
3	3	XXXX1XXX	011 _B		
4	4	XXX1XXXX	100 _B		
5	5	XX1XXXXX	101 _B		
6	6	X1XXXXXX	110 _B		
7	7	1XXXXXXX	111 _B		

Notes: This table indicates the range of row addresses in each masked segment. X is don't care for a particular segment.

MR18:19_(Reserved) (MA<7:0> = 012_H- 013_H):							
OP7	OP6	OP5	OP4	OP3	OP2	OP1	OP0
RFU							

MR20:31_(Do Not Use) (MA<7:0> = 014_H- 01F_H):							
OP7	OP6	OP5	OP4	OP3	OP2	OP1	OP0
Do Not Use							

512Mb LPDDR2-S4 SDRAM
NT6TL16M32AQ/ NT6TL32M16AQ

MR32_(Do Not Use) (MA<7:0> = 020_H):								
OP7	OP6	OP5	OP4	OP3	OP2	OP1	OP0	
Reads to MR32 return DQ calibration pattern A								

MR33:39_(Do Not Use) (MA<7:0> = 021_H- 027_H):								
OP7	OP6	OP5	OP4	OP3	OP2	OP1	OP0	
Do Not Use								

MR40_(Do Not Use) (MA<7:0> = 028_H):								
OP7	OP6	OP5	OP4	OP3	OP2	OP1	OP0	
Reads to MR32 return DQ calibration pattern A								

MR41:47_(Do Not Use) (MA<7:0> = 029_H- 02F_H):								
OP7	OP6	OP5	OP4	OP3	OP2	OP1	OP0	
Do Not Use								

MR48:62_(Reserved) (MA<7:0> = 030_H- 03E_H):								
OP7	OP6	OP5	OP4	OP3	OP2	OP1	OP0	
RFU								

MR63_Reset (MA<7:0> = 03F_H): MRW only								
OP7	OP6	OP5	OP4	OP3	OP2	OP1	OP0	
X								

Notes: For additional information on MRW RESET, see "Mode Register Write Command" on Timing Spec.

MR64:126_(Reserved) (MA<7:0> = 040_H- 07E_H):								
OP7	OP6	OP5	OP4	OP3	OP2	OP1	OP0	
RFU								

MR127_(Do Not Use) (MA<7:0> = 07F_H):								
OP7	OP6	OP5	OP4	OP3	OP2	OP1	OP0	
Do Not Use								

MR128:190_(Reserved for Vendor Use) (MA<7:0> = 080_H- 0BE_H):								
OP7	OP6	OP5	OP4	OP3	OP2	OP1	OP0	
RFU								

MR191_(Do Not Use) (MA<7:0> = 0BF_H):								
OP7	OP6	OP5	OP4	OP3	OP2	OP1	OP0	
Do Not Use								

MR192:254_(Reserved for Vendor Use) (MA<7:0> = 0C0_H- 0FE_H):								
OP7	OP6	OP5	OP4	OP3	OP2	OP1	OP0	
RFU								

MR255_(Do Not Use) (MA<7:0> = 0FF_H):								
OP7	OP6	OP5	OP4	OP3	OP2	OP1	OP0	
Do Not Use								

LPDDR2-S4 SDRAM Truth Table

Operation or timing that is not specified is illegal, and after such an event, in order to guarantee proper operation, the LPDDR2 device must be powered down and then restarted through the specified initialization sequence before normal operation can continue.

Command Truth Table

SDRAM command	SDR Command Pins			DDR CA pins (10)										CK EDGE			
	CKE		CS_n	CA0	CA1	CA2	CA3	CA4	CA5	CA6	CA7	CA8	CA9				
	CK_t(n-1)	CK_t(n)		MA0	MA1	MA2	MA3	MA4	MA5	MA6	MA7	OP0	OP1		OP2	OP3	OP4
MRW	H	H	L	L	L	L	L	MA0	MA1	MA2	MA3	MA4	MA5	↕			
				MA6	MA7	OP0	OP1	OP2	OP3	OP4	OP5	OP6	OP7	↕			
MRR	H	H	L	L	L	L	H	MA0	MA1	MA2	MA3	MA4	MA5	↕			
				MA6	MA7	x							↕				
Refresh (per bank) ¹¹	H	H	L	L	L	H	L	x						↕			
				x										↕			
Refresh (all bank)	H	H	L	L	L	H	H	x						↕			
				x										↕			
Enter Self Refresh	H	L	L	L	L	H	x						↕				
				x										↕			
Activate (bank)	H	H	L	L	H	R8	R9	R10	R11	R12	BA0	BA1	BA2	↕			
				R0	R1	R2	R3	R4	R5	R6	R7	R13	R14	↕			
Write (bank)	H	H	L	H	L	L	RFU	RFU	C1	C2	BA0	BA1	BA2	↕			
				AP ^{3,4}	C3	C4	C5	C6	C7	C8	C9	C10	C11	↕			
Read (bank)	H	H	L	H	L	H	RFU	RFU	C1	C2	BA0	BA1	BA2	↕			
				AP ^{3,4}	C3	C4	C5	C6	C7	C8	C9	C10	C11	↕			
Precharge (bank)	H	H	L	H	H	L	H	AB	x		BA0	BA1	BA2	↕			
				x										↕			
BST	H	H	L	H	H	L	L	x						↕			
				x										↕			
Enter Deep Power Down	H	L	L	H	H	L	x						↕				
				x										↕			
NOP	H	H	L	H	H	H	x						↕				
				x										↕			
Maintain PD, SREF, DPD (NOP)	L	L	L	H	H	H	x						↕				
				x										↕			
NOP	H	H	H	x										↕			
				x										↕			
Maintain PD, SREF, DPD (NOP)	L	L	H	x										↕			
				x										↕			
Enter Power Down	H	L	H	x										↕			
				x										↕			
Exit PD, SREF, DPD	L	H	H	x										↕			
				x										↕			

Notes:

1. All LPDDR2 commands are defined by states of CS_n, CA0, CA1, CA2, CA3, and CKE at the rising edge of the clock.
2. For LPDDR2 SDRAM, Bank addresses BA0, BA1, BA2 (BA) determine which bank is to be operated upon.
3. AP “high” during a READ or WRITE command indicates that an auto-precharge will occur to the bank associated with the READ or WRITE command.
4. “x” means “H or L (but a defined logic level)”.
5. Self refresh exit and Deep Power Down exit are asynchronous.
6. V_{REF} must be between 0 and V_{DDQ} during Self Refresh and Deep Down operation.
7. CAx_r refers to command/address bit “x” on the rising edge of clock.
8. CAx_f refers to command/address bit “x” on the falling edge of clock.
9. CS_n and CKE are sampled at the rising edge of clock.
10. Per Bank Refresh is only allowed in devices with 8 banks.
11. The least-significant column address C0 is not transmitted on the CA bus, and is implied to be zero.

CKE Truth Table

Device Current State ^{*3}	CKE _{n-1} ^{*1}	CKE _n ^{*1}	CS _n ^{*2}	Command n ^{*4}	Operation n ^{*4}	Device Next State	Notes
Active Power Down	L	L	x	x	Maintain Active Power Down	Active Power Down	
	L	H	H	NOP	Exit Active Power Down	Active	6,9
Idle Power Down	L	L	x	x	Maintain Idle Power Down	Idle Power Down	
	L	H	H	NOP	Exit Idle Power Down	Idle	6,9
Resetting Power Down	L	L	x	x	Maintain Resetting Power Down	Resetting Power Down	
	L	H	H	NOP	Exit Resetting Power Down	Idle or Resetting	6,9,12
Deep Power Down	L	L	x	x	Maintain Deep Power Down	Deep Power Down	
	L	H	H	NOP	Exit Deep Power Down	Power On	8
Self Refresh	L	L	x	x	Maintain Self Refresh	Self Refresh	
	L	H	H	NOP	Exit Self Refresh	Idle	7,10
Bank(s) Active	H	L	H	NOP	Enter Active Power Down	Active Power Down	
All Banks Idle	H	L	H	NOP	Enter Idle Power Down	Idle Power Down	
	H	L	L	Enter Self-Refresh	Enter Self Refresh	Self Refresh	
	H	L	L	Enter Self-Refresh	Enter Deep Power Down	Deep Power Down	
Resetting	H	L	H	NOP	Enter Resetting Power Down	Resetting Power Down	
Other states	H	H	Refer to the Command Truth Table				

Notes:

1. “CKE_n” is the logic state of CKE at clock edge n; “CKE_{n-1}” was the logic state of CKE at previous clock edge.
2. “CS_n” is the logic state of CS_n at the clock rising edge n;
3. “Current state” is the state of the LPDDR2 device immediately prior to clock edge n.
4. “Command n” is the command registered at clock edge N, and “Operation n” is a result of “Command n”.
5. All states and sequences not shown are illegal or reserved unless explicitly described elsewhere in this document.
6. Power Down exit time (t_{XP}) should elapse before a command other than NOP is issued.
7. Self-Refresh exit time (t_{XSR}) should elapse before a command other than NOP is issued.
8. The Deep Power-Down exit procedure must be followed as discussed in the DPD section of the Functional Description.
9. The clock must toggle at least once during the t_{XP} period.

10. The clock must toggle at least once during the t_{XSR} period.
11. “x” means “Don’t care”.
12. Upon exiting Resetting Power Down, the device will return to the idle state if t_{INIT5} has expired.

Current State Bank n – Command to Bank n

Current State	Command	Operation	Next State	Notes
Any	NOP	Continue previous operation	Current State	
Idle	ACTIVATE	Select and activate row	Active	
	Refresh (Per Bank)	Begin to refresh	Refreshing (Per Bank)	6
	Refresh (All Bank)	Begin to refresh	Refreshing (AllBank)	7
	MRW	Load value from Mode Register	MR Writing	7
	MRR	Read value from Mode Register	Idle / MR Reading	
	Reset	Begin Device Auto-initialization	Resetting	7,8
	Precharge	Deactivate row in bank or banks	Precharging	9,15
Row Active	Read	Select column, and start read burst	Reading	
	Write	Select column, and start write burst	Writing	
	MRR	Read value from Mode Register	Active / MR Reading	
	Precharge	Deactivate row in bank or banks	Precharging	9
Reading	Read	Select column, and start new read burst	Reading	10,11
	Write	Select column, and start write burst	Writing	10,11,12
	BST	Read burst terminate	Active	13
Writing	Write	Select column, and start new write burst	Writing	10,11
	Read	Select column, and start read burst	Reading	10,11,14
	BST	Write burst terminate	Active	13
Power On	Reset	Begin Device Auto-initialization	Resetting	7,9
Resetting	MRR	Read value from Mode Register	Resetting MR Reading	

Notes:

1. The table applies when both CKE_{n-1} and CKE_n are HIGH, and after t_{XSR} or t_{XP} has been met, if the previous state was Power Down.
2. All states and sequences not shown are illegal or reserved.
3. Current State definitions:

State	Definition
Idle	The bank or banks have been precharged, and t_{RP} has been met.
Active	A row in the bank has been activated, and t_{RCD} has been met. No data bursts or accesses and no register accesses are in progress.
Reading	A READ burst has been initiated with auto precharge disabled, and has not yet terminated or been terminated.
Writing	A WRITE burst has been initiated with auto precharge disabled, and has not yet terminated or been terminated.

4. The following states must not be interrupted by a command issued to the same bank. NOP commands or allowable commands to the other bank should be issued on any clock edge occurring during these states.

State	Starts with	Ends when	Notes
Refreshing (per bank)	Registration of a REFRESH (per bank) command	tRFCpb is met	After tRFCpb is met, the bank is in the idle state.
Refreshing (all banks)	Registration of a REFRESH (allbank) command	tRFCab is met	After tRFCab is met, the device is in the all-banksidle state.
Idle MR reading	Registration of the MRR command	tMRR is met	After tMRR is met, the device is in the all-banksidle state..
Resetting MR reading	Registration of the MRR command	tMRR is met	After tMRR is met, the device is in the all-banksidle state.
Active MR reading	Registration of the MRR command	tMRR is met	After tMRR is met, the bank is in the active state.
MR writing	Registration of the MRW command	tMRW is met	After tMRW is met, the device is in the all-banksidle state.
Precharge all	Registration of a PRECHARGE ALL command	tRP is met	After tRP is met, the device is in the all-banksidle state.

5. The states listed below must not be interrupted by any executable command. NOP commands must be applied to each positive clock edge during these states.

State	Starts with	Ends when	Notes
Precharging	Registration of a PRECHARGE command	tRP is met	After tRP is met, the bank is in the idle state.
Row Active	Registration of an ACTIVATE command	tRCD is met	After tRCD is met, the bank is in the active state.
READ with AP enable	Registration of a READ command with auto precharge enabled	tRP is met	After tRP is met, the bank is in the idle state.
WRITE with AP enable	Registration of a WRITE command with auto precharge enabled	tRP is met	After tRP is met, the bank is in the idle state.

6. Bank-specific; requires that the bank is idle and no bursts are in progress.
7. Not bank-specific; requires that all banks are idle and no bursts are in progress.
8. Not bank-specific reset command is achieved through Mode Register Write command.
9. This command may or may not be bank specific. If all banks are being precharged, the must be in a valid state for precharging.
10. A command other than NOP should not be issued to the same bank while a READ or WRITE burst with auto precharge is enabled.
11. The new READ or WRITE command could be auto precharge enabled or auto precharge disabled.

12. A WRITE command can be issued after the completion of the READ burst; otherwise, a BST must be issued to end the READ prior to asserting a WRITE command.
13. Not bank-specific. The BST command affects the most recent READ/WRITE burst started by the most recent READ/WRITE command, regardless of bank.
14. A READ command can be issued after completion of the WRITE burst; otherwise, a BST must be used to end the WRITE prior to asserting another READ command.
15. If a PRECHARGE command is issued to a bank in the idle state, tRP still applies.

Current State Bank n – Command to Bank m

Current State of Bank n	Command for Bank m	Operation	Next State for Bank m	Notes
Any	NOP	Continue previous operation	Current State of Bank m	
Idle	Any	Any command allowed to Bank m	-	18
Row Activating, Active, or Precharging	Activate	Select and activate row in Bank m	Active	7
	Read	Select column, and start read burst from Bank m	Reading	8
	Write	Select column, and start write burst to Bank m	Writing	8
	Precharge	Deactivate row in bank or banks	Precharging	9
	MRR	Read value from Mode Register	Idle MR Reading or Active MR Reading	10,11,13
	BST	Read or Write burst terminate an ongoing Read/Write from/to Bank m	Active	18
Reading (AP disabled)	Read	Select column, and start read burst from Bank m	Reading	8
	Write	Select column, and start write burst to Bank m	Writing	8,14
	Activate	Select and activate row in Bank m	Active	
	Precharge	Deactivate row in bank or banks	Precharging	9
Writing (AP disabled)	Read	Select column, and start read burst from Bank m	Reading	8,16
	Write	Select column, and start write burst to Bank m	Writing	8
	Activate	Select and activate row in Bank m	Active	
	Precharge	Deactivate row in bank or banks	Precharging	9
Reading with Auto-Precharge	Read	Select column, and start read burst from Bank m	Reading	8,15
	Write	Select column, and start write burst to Bank m	Writing	8,14,15
	Activate	Select and activate row in Bank m	Active	
	Precharge	Deactivate row in bank or banks	Precharging	9
Writing with Auto-Precharge	Read	Select column, and start read burst from Bank m	Reading	8,15,16
	Write	Select column, and start write burst to Bank m	Writing	8,15
	Activate	Select and activate row in Bank m	Active	
	Precharge	Deactivate row in bank or banks	Precharging	9
Power On	Reset	Begin Device Auto-initialization	Resetting	12,17
Resetting	MRR	Read value from Mode Register	Resetting MR Reading	

Notes:

1. The table applies when both CKE_{n-1} and CKE_n are HIGH, and after t_{XSR} or t_{XP} has been met, if the previous state was Self Refresh or Power Down.
2. All states and sequences not shown are illegal or reserved.
3. Current State definitions:

- 3.1) Idle: the bank has been precharged, and tRP has been met
- 3.2) Active: a row in the bank has been activated, and tRCD has been met. No data bursts/accesses and no register accesses are in progress.
- 3.3) Reading: a Read burst has been initiated, with Auto Precharge disabled, and has not yet terminated or been terminated.
- 3.4) Writing: a Write burst has been initiated, with Auto Precharge disabled, and has not yet terminated or been terminated.
4. Refresh, Self-Refresh, and Mode Register Write commands may only be issued when all bank are idle.
5. A Burst Terminate (BST) command can not be issued to another bank; it applies to the bank represented by the current state only.
6. The following states must not be interrupted by any executable command; NOP commands must be applied during each clock cycle while in these states:
 - 6.1) Idle MR Reading: starts with the registration of a MRR command and ends when tMRR has been met. Once tMRR has been met, The bank will be in the Idle state.
 - 6.2) Resetting MR Reading: starts with the registration of a MRR command and ends when tMRR has been met. Once tMRR has been met, the bank will be in the Resetting state.
 - 6.3) Active MR Reading: starts with the registration of a MRR command and ends when tMRR has been met. Once tMRR has been met, the bank will be in the Active state.
 - 6.4) MR Writing: starts with the registration of a MRW command and ends when tMRW has been met. Once tMRW has been met, the bank will be in the Idle state.
7. tRRD must be met between the ACTIVATE command to bank *n* and any subsequent ACTIVATE command to bank *m*.
8. READs or WRITEs listed in the command column include READs and WRITEs with or without auto precharge enabled.
9. This command may or may not be bank specific. If all banks are being precharged, they must be in a valid state for precharging.
10. MRR is supported in the row-activating state.
11. MRR is supported in the precharging state.
12. Not bank-specific; requires that all banks are idle and no bursts are in progress.
13. The next state for bank *m* depends on the current state of bank *m* (idle, row-activating, precharging, or active).
14. A WRITE command can be issued after the completion of the READ burst; otherwise a BST must be issued to end the READ prior to asserting a WRITE command.
15. A READ with auto precharge enabled or a WRITE with auto precharge enabled can be followed by any valid command to other banks with timing restriction.
16. A READ command can be issued after the completion of the WRITE burst; otherwise, a BST must be issued to end the WRITE prior to asserting another READ command.
17. RESET command is achieved through MODE REGISTER WRITE command.
18. BST is supported only if a READ or WRITE burst is ongoing.

DM Operation Truth Table

Function	DM	DQ	Notes
Write Enable	L	Valid	1
Write Inhibit	H	X	1

Notes:

- Used to mask write data, provided coincident with the corresponding data.

COMMAND Definitions and Timing Diagrams

ACTIVE

The Active command is issued by holding CS_n LOW, CA0 LOW, and CA1 HIGH at the rising edge of the clock. The bank addresses BA0-BA2 are used to select the desired bank. The row addresses R0-R14 is used to determine which row in the selected bank. The Active command must be applied before any Read or Write operation can be executed. The LPDDR2 SDRAM can accept a read or write command at time ^tRCD after the active command is sent. Once a bank has been active, it must be precharged before another Active command can be applied to the same bank. The bank active and precharge times are defined as ^tRAS and ^tRP, respectively. The minimum time interval between two successive ACTIVE commands on the same bank is determined by the RAS cycle time of the device (^tRC). The minimum time interval between two successive ACTIVE commands on different banks is defined by ^tRRD.

Certain restriction on operation of the 8 bank devices must be observed. One for restricting the number of sequential Active commands that can be issued and another for allowing more time for RAS precharge for a Precharge All command. The rules are as follows:

- 8 bank device Sequential Bank Activation Restriction:** No more than 4 banks may be activated (or refreshed, in the case of REF_{pb}) in a rolling ^tFAW window. Converting to clocks is done by dividing ^tFAW[ns] by ^tCK[ns], and rounding up to the next integer value. An example of the rolling window, if $\text{RU}(\{^t\text{FAW} / ^t\text{CK}\})$ is 10 clocks, and an activate command is issued in clock N, no more than three further activate commands may be issued at or between clock N+1 and N+9. REF_{pb} also counts as bank-activation for the purposes of ^tFAW.
- 8 bank device Precharge All allowance:** ^tRP for a Precharge All command for an 8 Bank device shall equal to ^tRP_{ab}, which is greater than ^tRP_{pb}.

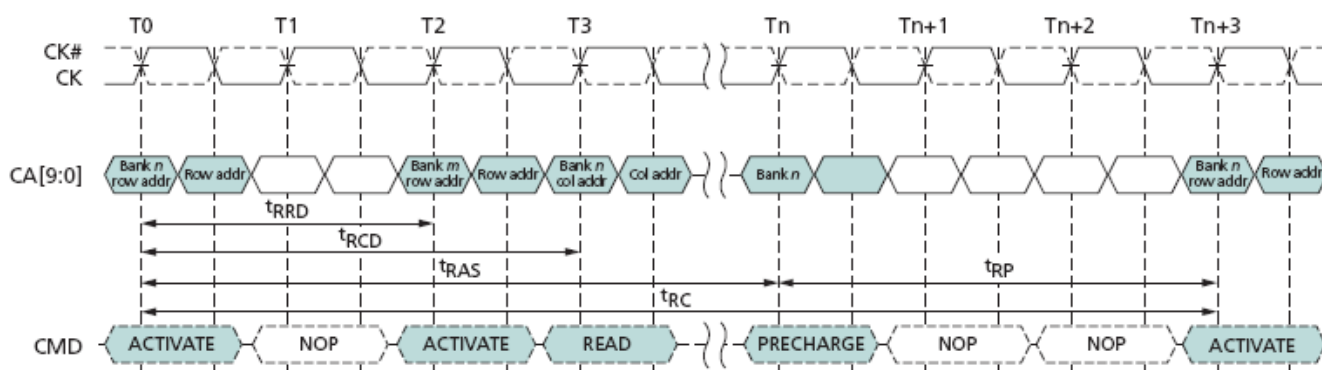

Activate command cycle: ^tRCD=3, ^tRP=3, ^tRRD=2

Notes:

1. A Precharge-All command uses tRPab timing, while a Single Bank Precharge command uses tRPpb timing. In this figure, tRP is used to denote either an All-bank Precharge or a Single Bank Precharge.

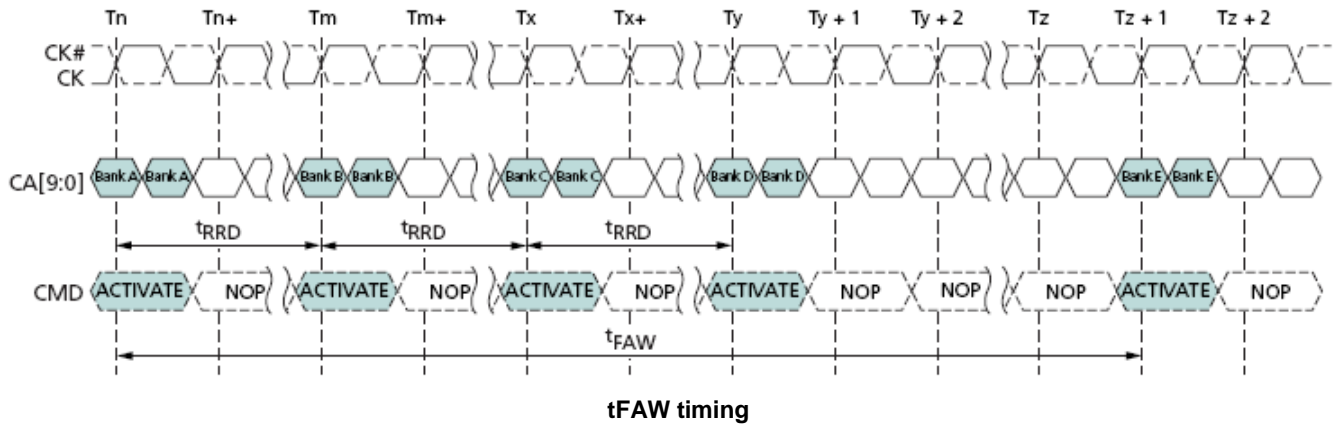

Notes:

1. Exclusively for 8-bank devices. No more than 4 banks may be activated in a rolling tFAW window.

Command Input Signal Timing Definition

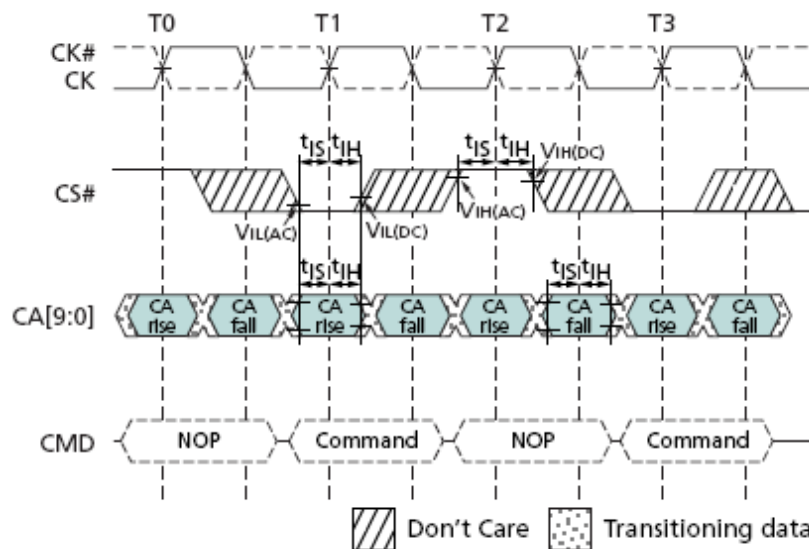

Command Input Setup and Hold Timing

Notes:

1. Setup and hold conditions also apply to the CKE pin.

Read and Write access modes

After a bank has been activated, a read or write cycle can be executed. This is accomplished by setting CS_n LOW, CA0 HIGH, and CA1 LOW at the rising edge of the clock. CA2 must also be defined at this time to determine whether the access cycle is a read operation (CA2 HIGH) or a write operation (CA2 LOW).

The LPDDR2 SDRAM provides a fast column access operation. A single Read or Write Command will initiate a burst read or write operation on successive clock cycles.

For LPDDR2-S4 devices, a new burst access must not interrupt the previous 4-bit burst operation, in case of BL=4 setting. In case of BL=8 and BL=16 settings, Reads may be interrupted by Reads, and Writes may be interrupted by Writes provided that this occurs on even clock cycles after the Read or Write command and that ^tCCD is met. The minimum CAS to CAS delay is defined by ^tCCD.

Burst Read

The Burst Read command is initiated by having CS_n LOW, CA0 HIGH, CA1 LOW and CA2 HIGH at the rising edge of the clock. The command address bus inputs, CA5r-CA6r and CA1f-CA9f, determine the starting column address for the burst. The Read Latency (RL) is defined from the rising edge of the clock on which the Read Command is issued to the rising edge of the clock from which the ^tDQSCK delay is measured. The first valid datum is available $RL * ^tCK + ^tDQSCK + ^tDQSQ$ after the rising edge of the clock where the Read Command is issued. The data strobe output is driven LOW ^tRPRE before the first rising valid strobe edge. The first bit of the burst is synchronized with the first rising edge of the data strobe. Each subsequent data-out appears on each DQ pin edge aligned with the data strobe. The RL is programmed in the mode registers. Timings for the data strobe are measured relative to the crosspoint of DQS and its complement, DQS_c.

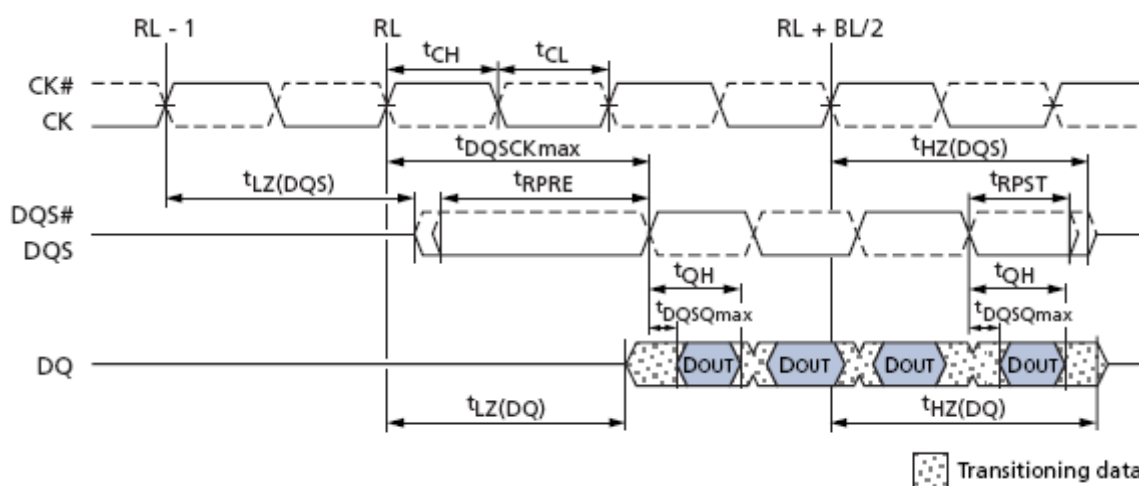

Data output (Read) timing (^tDQSQmax)

Notes:

1. ^tDQSQ can span multiple clock periods.
2. An effective Burst Length of 4 is shown.

Burst Read (Continued)

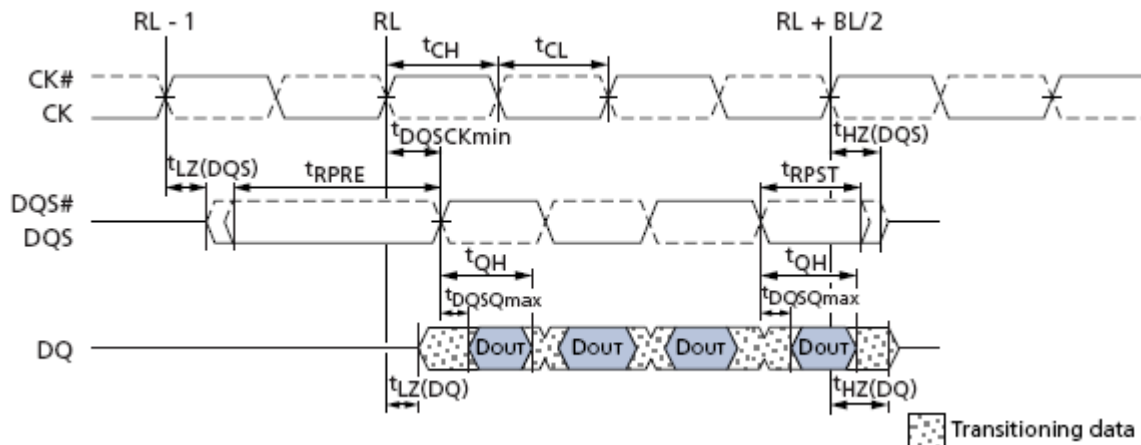

Data output (Read) timing ($t_{DQSCmin}$), BL=4

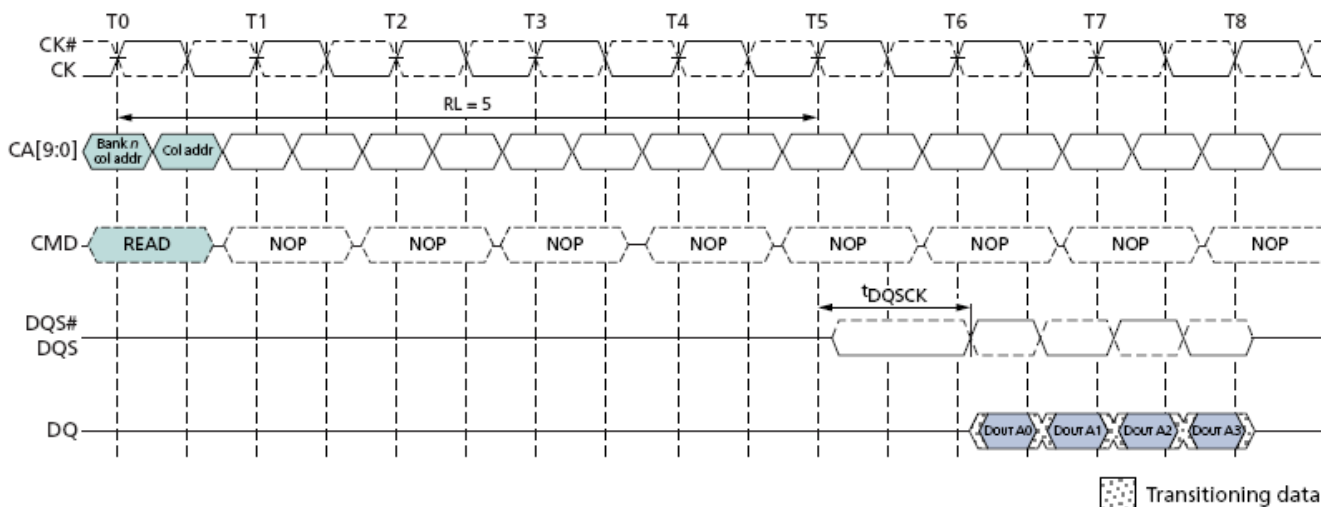

Burst Read: RL=5, BL=4, $t_{DQSC} > t_{CK}$

512Mb LPDDR2-S4 SDRAM

NT6TL16M32AQ/ NT6TL32M16AQ

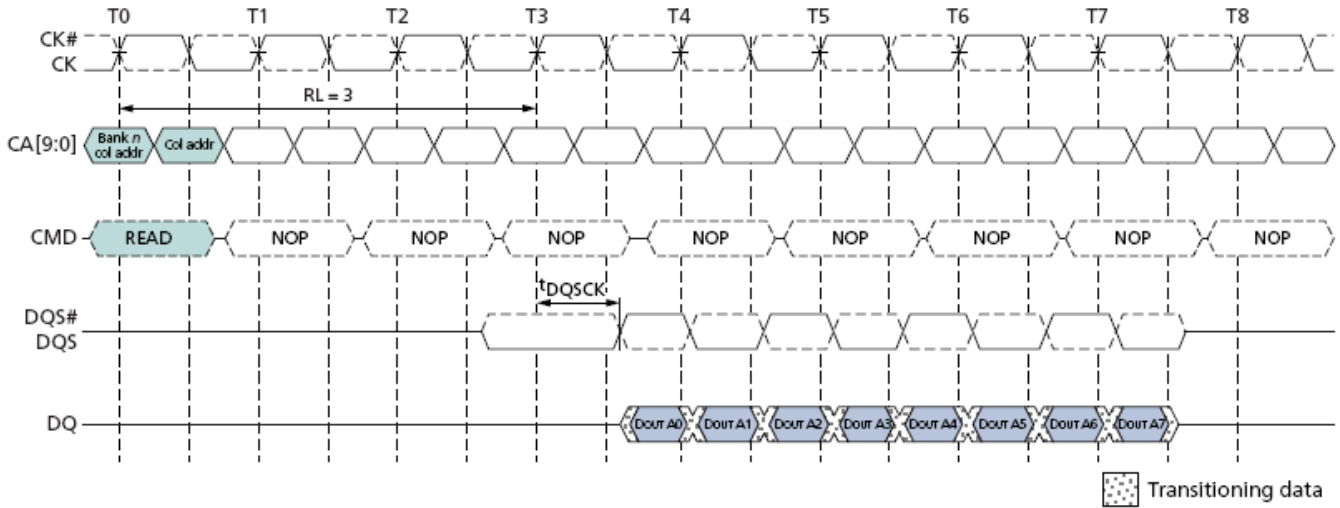

Burst Read: RL=3, BL=8, tDQSCK < tCK

Burst Read (Continued)

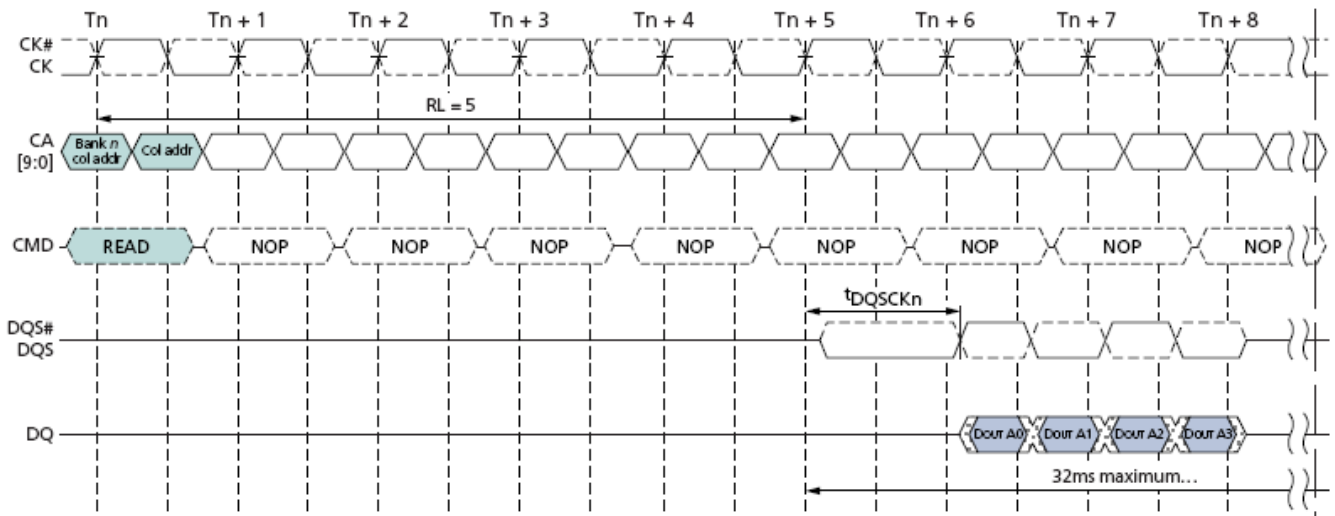

1

512Mb LPDDR2-S4 SDRAM

NT6TL16M32AQ/ NT6TL32M16AQ

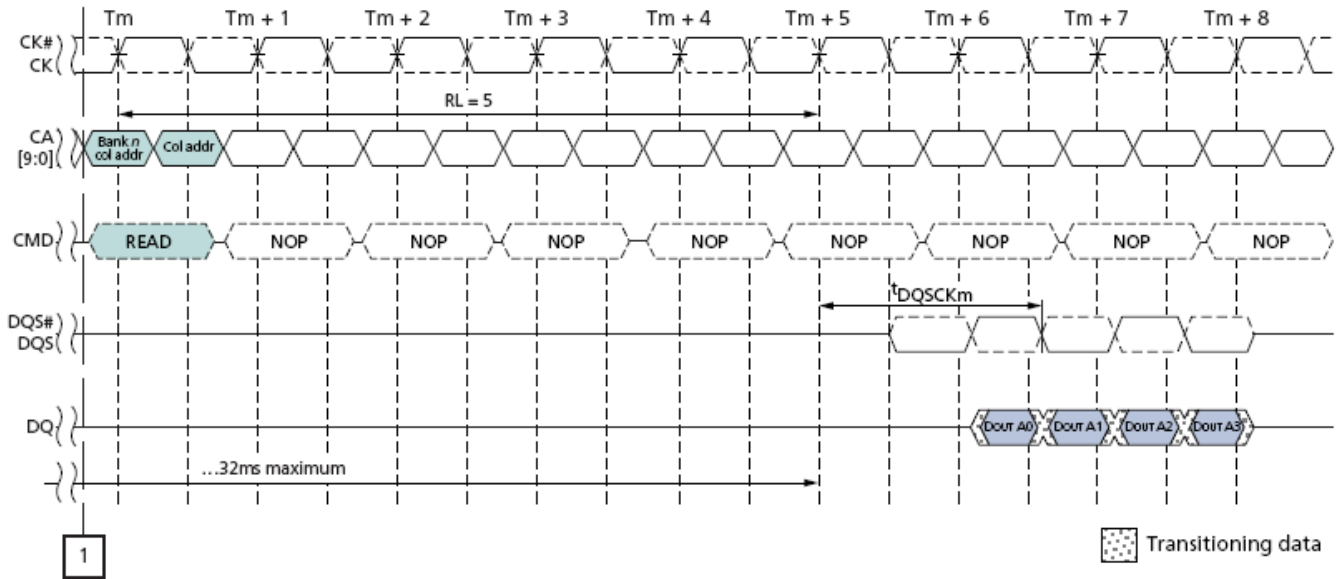

tDQSCKDL timing : $tDQSCKDL = |tDQSCKn - tDQSCKm|$ within any 32ms rolling window

Notes:

1. tDQSCKDLmax is defined as the maximum of $ABS(tDQSCKn - tDQSCKm)$ for any $\{tDQSCKn - tDQSCKm\}$ pair within any 32ms rolling window.

Burst Read (Continued)

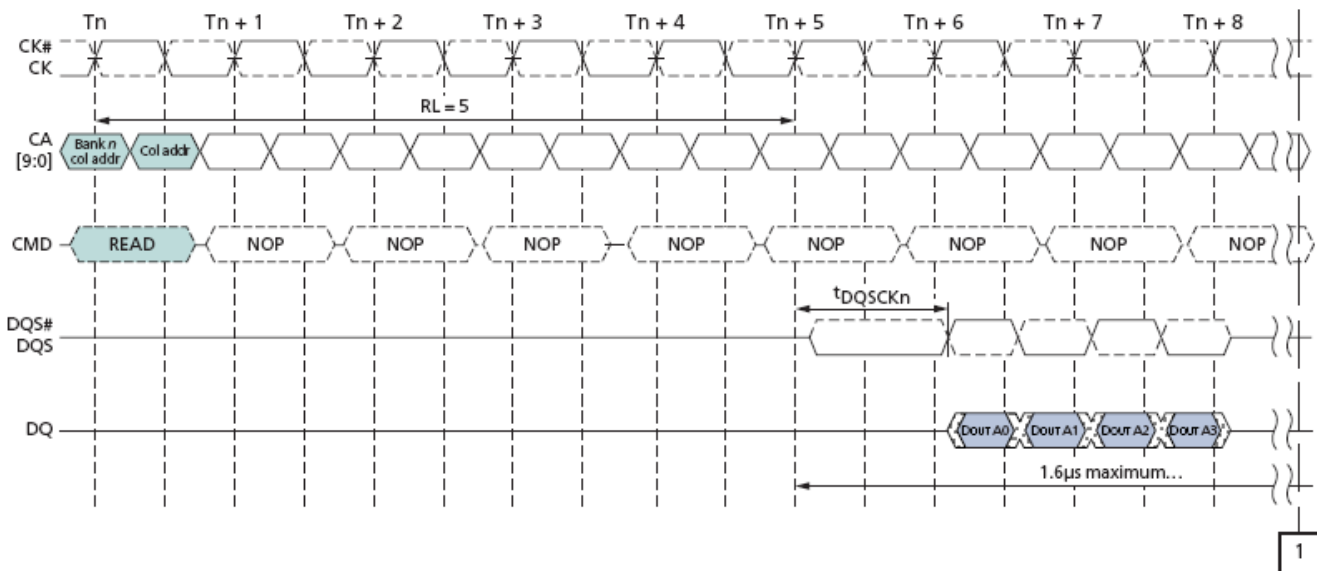

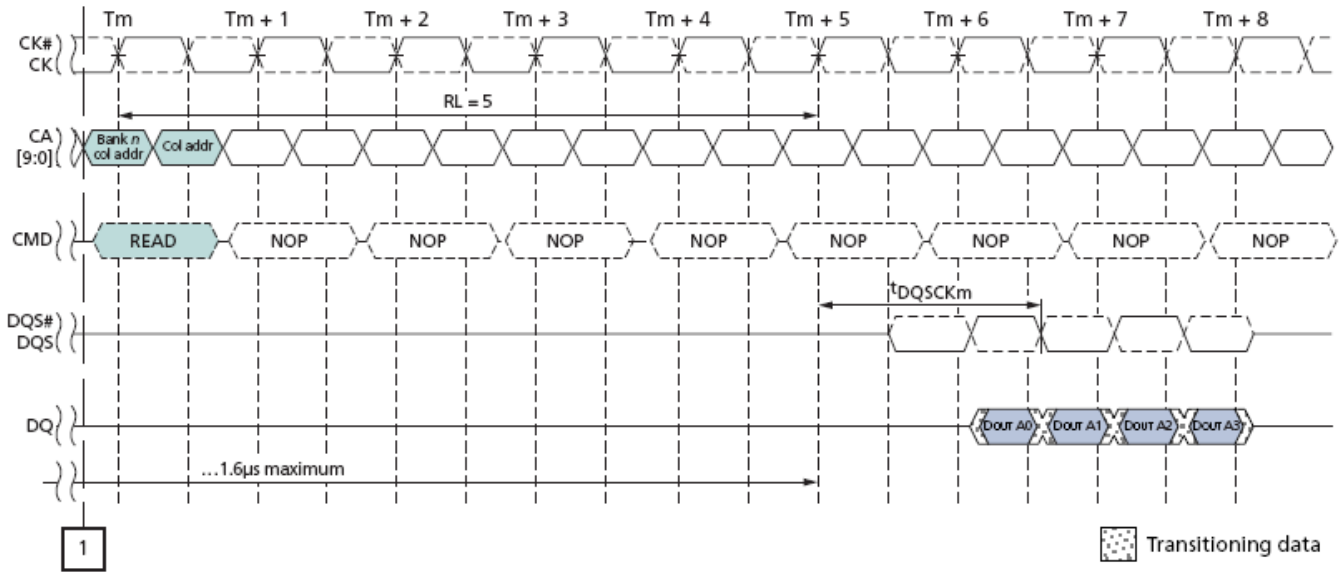

tDQCKDM timing : $tDQCKDM = |tDQCKn - tDQCKm|$ within any 1.6µs rolling window

Notes:

1. tDQCKDMmax is defined as the maximum of $ABS(tDQCKn - tDQCKm)$ for any $\{tDQCKn - tDQCKm\}$ pair within any 1.6µs rolling window.

Burst Read (Continued)

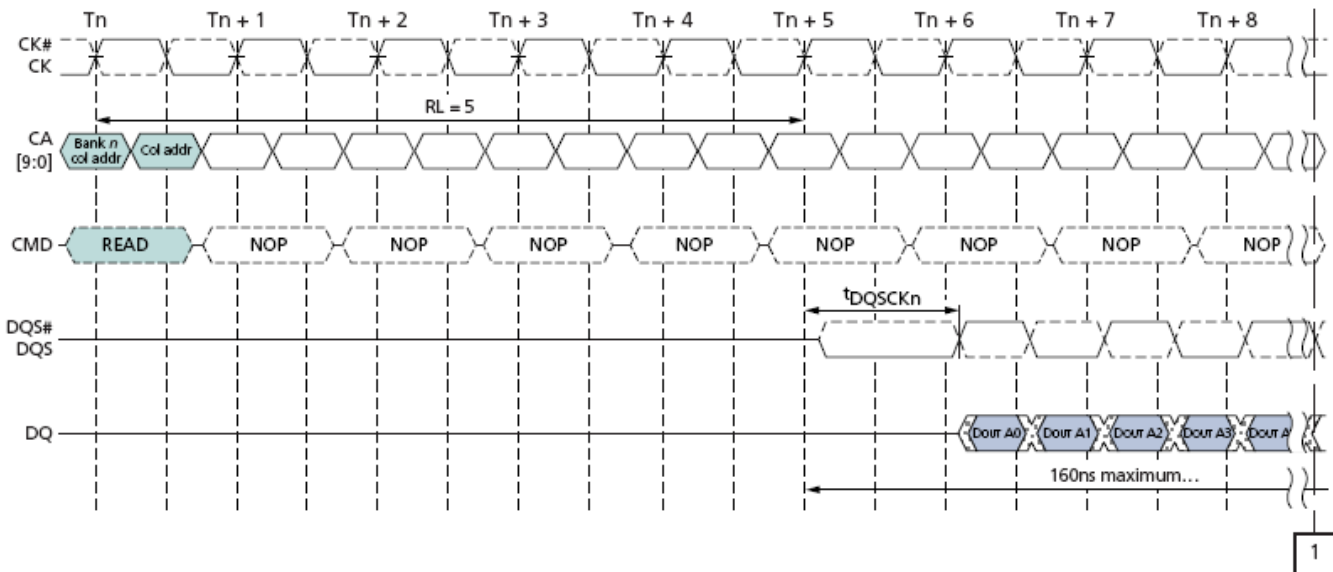

512Mb LPDDR2-S4 SDRAM

NT6TL16M32AQ/ NT6TL32M16AQ

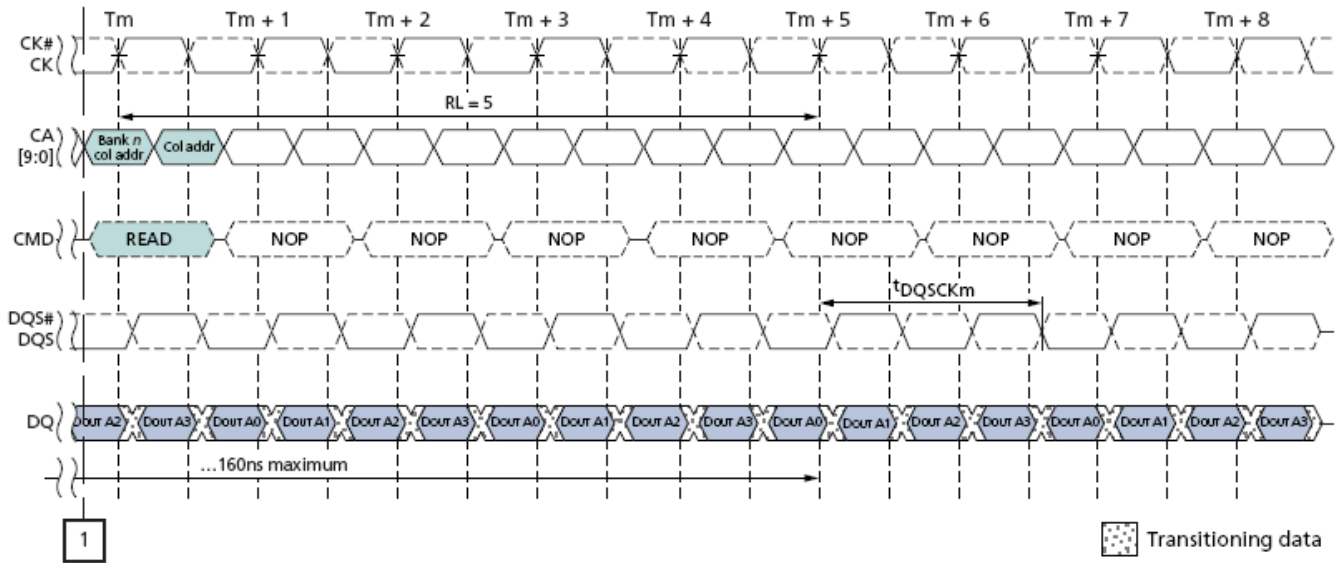

tDQSKDS timing : $tDQSKDS = |tDQSKn - tDQSKm|$ within a consecutive burst within any 160ns rolling window

Notes:

1. tDQSKDSmax is defined as the maximum of $ABS(tDQSKn - tDQSKm)$ for any $\{tDQSKn - tDQSKm\}$ pair for reads within a consecutive burst within any 160ns rolling window.

Burst Read (Continued)

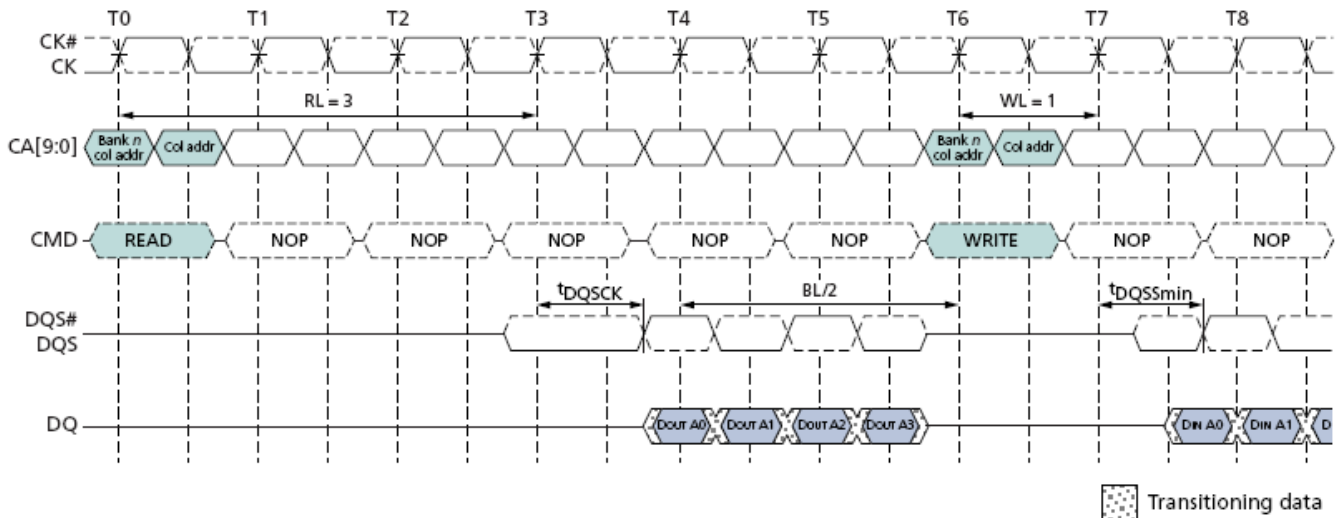

Burst Read followed by burst write: RL=3, WL=1, BL=4

The minimum time from the burst READ command to the burst WRITE command is defined by the read latency (RL) and the burst length (BL). Minimum READ-to-WRITE latency is $RL + RU(tDQSK(MAX)/tCK) + BL/2 + 1 - WL$ clock cycles. Note that if a READ burst is truncated with a burst TERMINATE (BST) command, the effective burst length of the truncated READ burst should be used as "BL" to calculate the minimum READ-to-WRITE delay.

512Mb LPDDR2-S4 SDRAM

NT6TL16M32AQ/ NT6TL32M16AQ

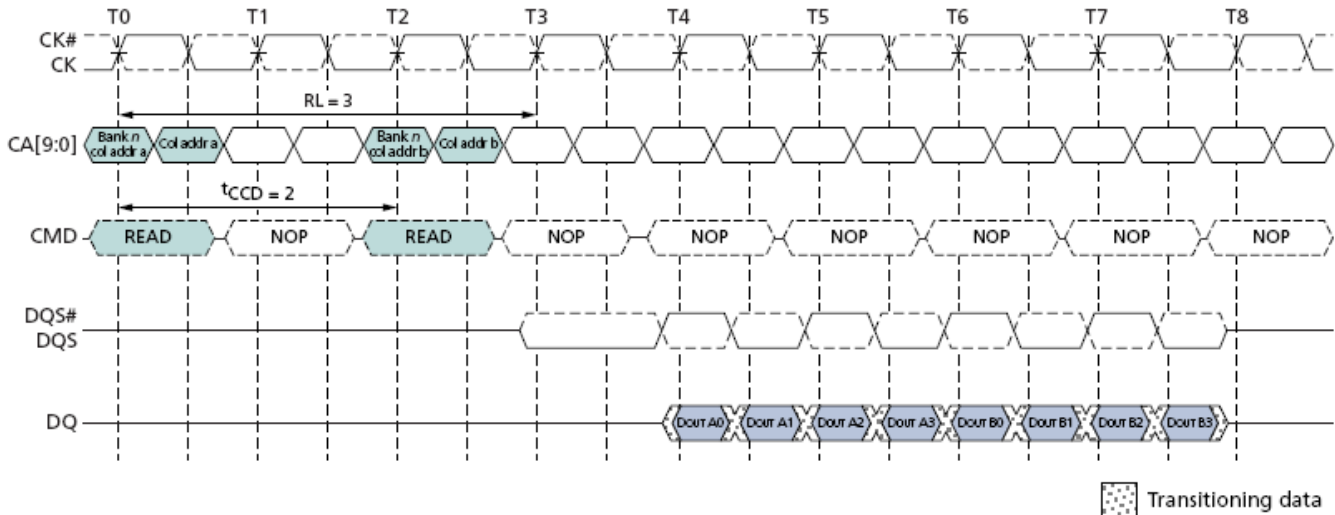

Seamless Burst Read: RL=3, BL=4, tCCD=2

The seamless burst READ operation is supported by enabling a READ command at every other clock cycle for BL = 4 operation, every fourth clock cycle for BL = 8 operation, and every eighth clock cycle for BL=16 operation. This operation is supported as long as the banks are activated, whether the accesses read the same or different banks.

Burst Read (Continued)

For LPDDR2-S4 devices, burst read can be interrupted by another read on even clock cycles after the Read command, provided that t_{CCD} is met. For LPDDR2-S2 devices, burst reads may be interrupted by other reads on any subsequent clock, provided that t_{CCD} is met.

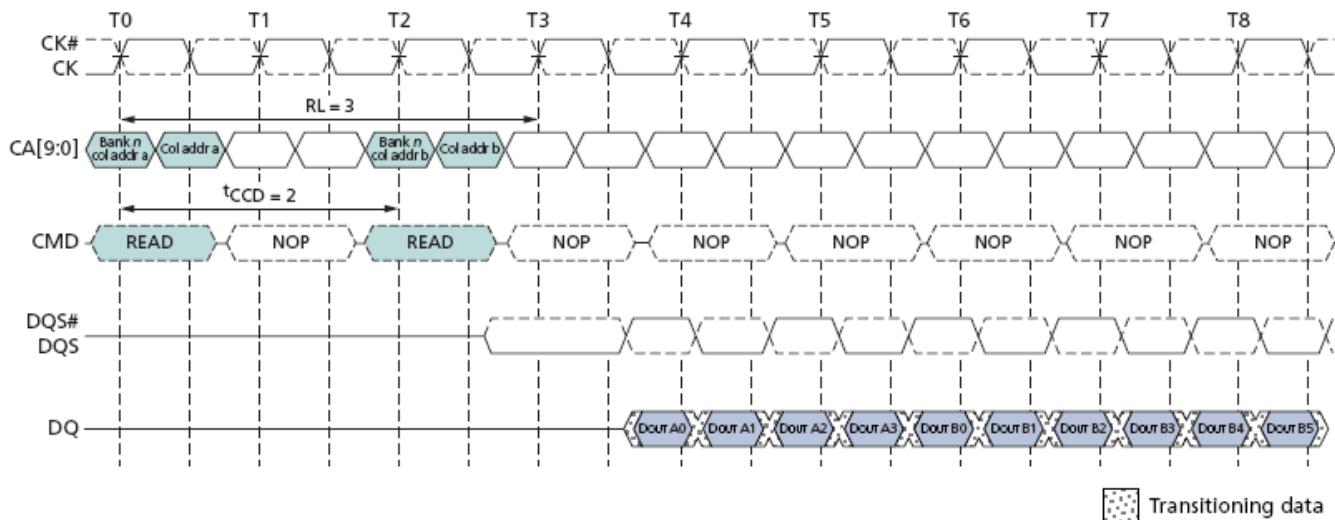

Read burst interrupt example: RL=3, BL=8, t_{CCD}=2

Notes:

1. Reads can only be interrupted by other reads or the BST command.
2. The effective burst length of the first read equals two times the number of clock cycles between the first read and the interrupting read.

Burst Write

The burst WRITE command is initiated with \overline{CS} LOW, CA0 HIGH, CA1 LOW, and CA2 LOW at the rising edge of the clock. The command address bus inputs, CA5r–CA6r and CA1f–CA9f, determine the starting column address for the burst. Write latency (WL) is defined from the rising edge of the clock on which the WRITE command is issued to the rising edge of the clock from which the tDQSS delay is measured. The first valid data must be driven $WL \times tCK + tDQSS$ from the rising edge of the clock from which the WRITE command is issued. The data strobe signal (DQS) must be driven LOW tWPRE prior to data input. The burst cycle data bits must be applied to the DQ pins tDS prior to the associated edge of the DQS and held valid until tDH after that edge. Burst data is sampled on successive edges of the DQS until the 4-, 8-, or 16-bit burst length is completed. After a burst WRITE operation, tWR must be satisfied before a PRECHARGE command to the same bank can be issued.

Pin input timings are measured relative to the cross point of DQS and its complement, \overline{DQS} .

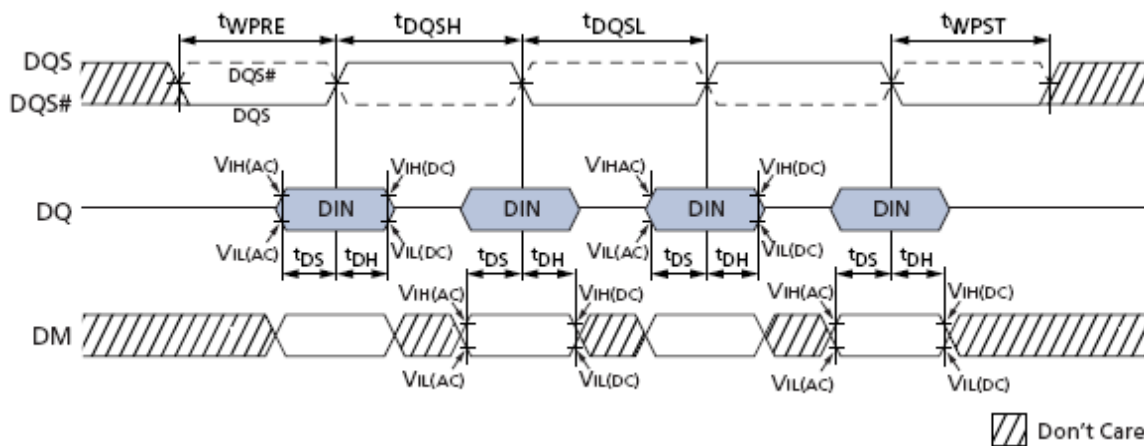

Data input (Write) timing

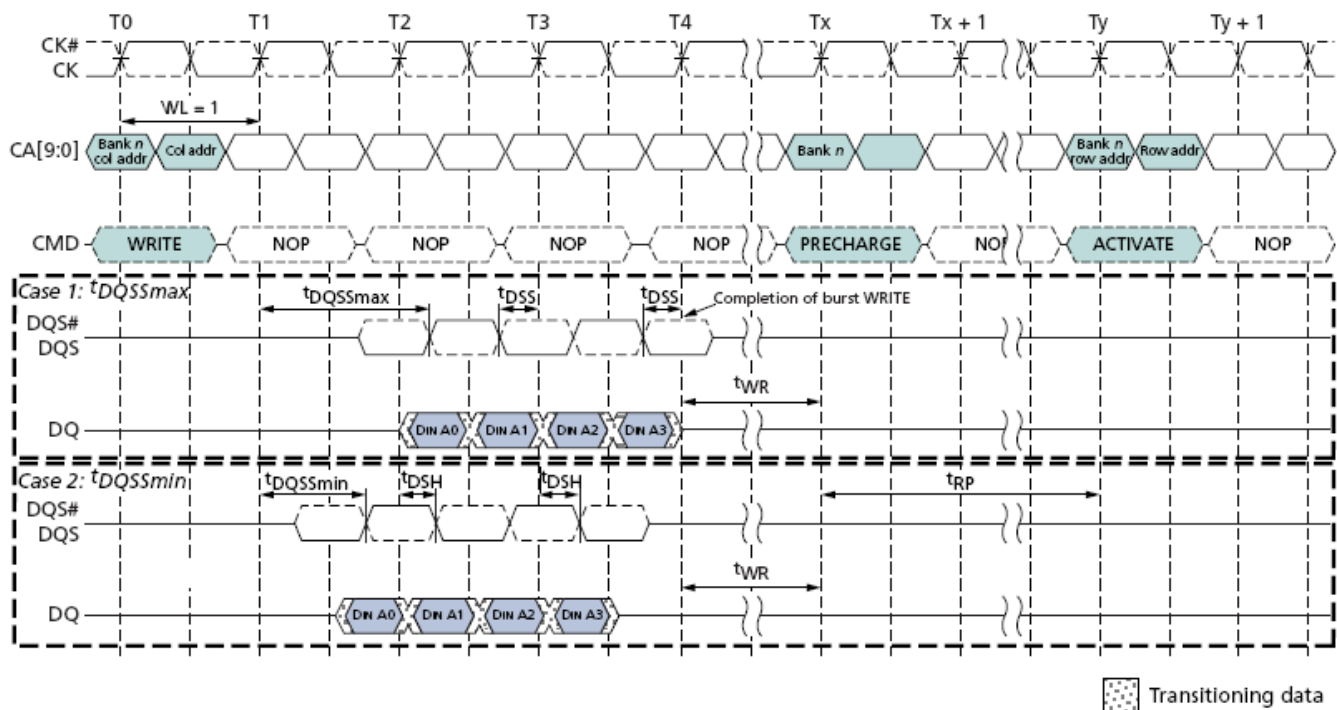

Burst write: WL=1, BL=4

Burst Write (Continued)

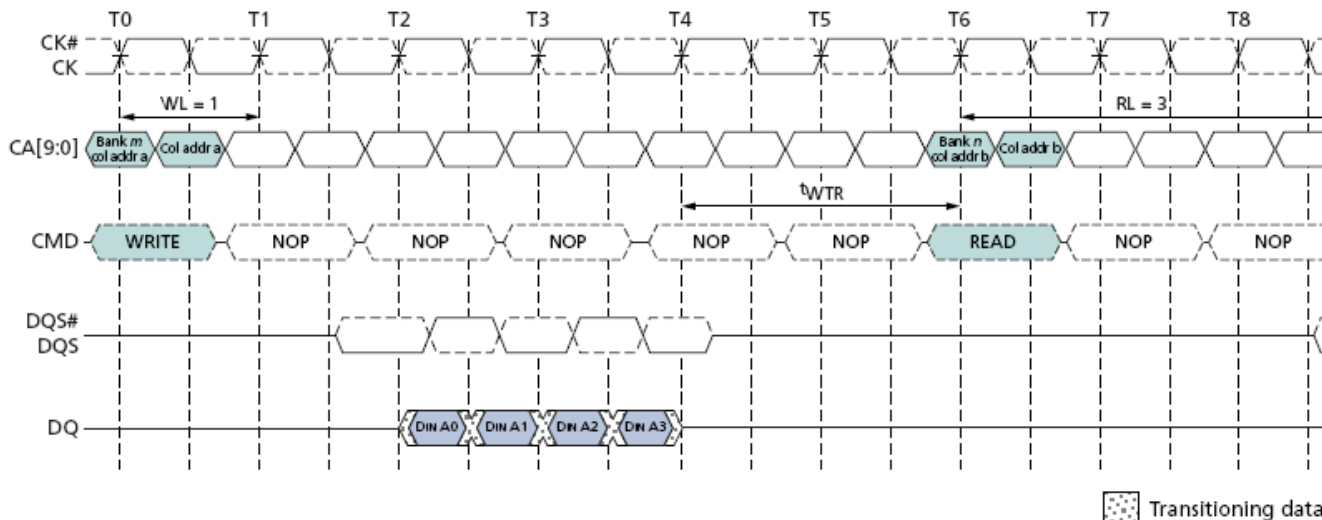

Burst write followed by burst read: RL=3, WL=1, BL=4

Notes:

1. The minimum number of clock cycles from the burst write command to the burst read command for any bank is $[WL + 1 + BL/2 + RU (tWTR / tCK)]$.
2. $tWTR$ starts at the rising edge of the clock after the last valid input datum.
3. If a write burst is truncated with a Burst Terminate (BST) command, the effective burst length of the truncated write burst should be used as "BL" to calculate the minimum write to read delay.

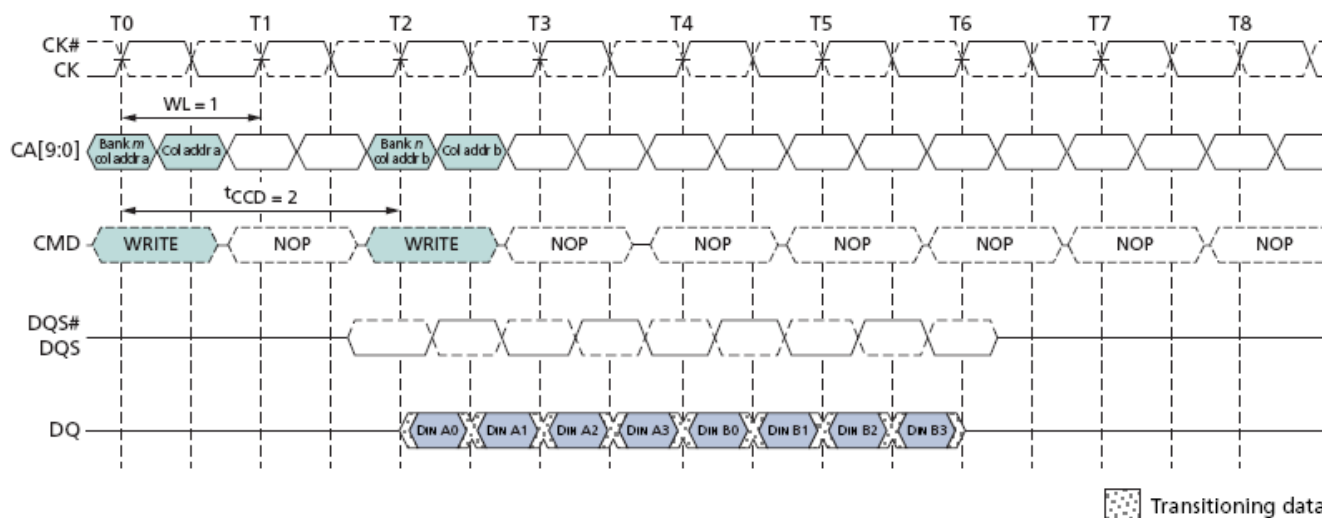

Seamless Burst write: WL=1, BL=4, tCCD=2

Notes:

1. The seamless burst write operation is supported by enabling a write command every other clock for BL=4 operation, every four clocks for BL=8 operation, or every eight clocks for BL=16 operation. This operation is allowed regardless of same or different banks as long as the banks are activated.

Burst Write (Continued)

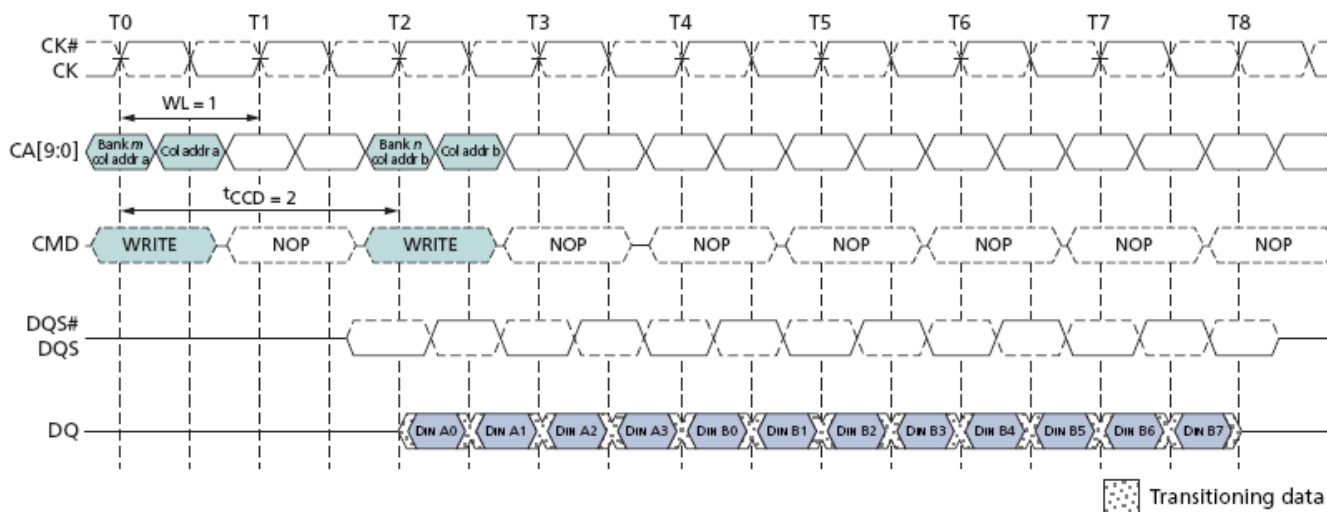

Write burst interrupt timing: WL=1, BL=8, tCCD=2

Notes:

1. WRITES can only be interrupted by other WRITES or the BST command.
2. For LPDDR2-S4 devices, write burst interrupt function is only allowed on burst of 8 and burst of 16.
3. For LPDDR2-S4 devices, write burst interrupt may only occur on even clock cycles after the previous write commands, provided that $t_{CCD}(\min)$ is met.
4. Write burst interruption is allowed to any bank inside DRAM.
5. Write burst with Auto-Precharge is not allowed to be interrupted.
6. The effective burst length of the first WRITE equals two times the number of clock cycles between the first WRITE and the interrupting WRITE.

Burst Terminate [BST]

The BST command is initiated with \overline{CS} LOW, CA0 HIGH, CA1 HIGH, CA2 LOW, and CA3 LOW at the rising edge of the clock. A BST command can only be issued to terminate an active READ or WRITE burst. Therefore, a BST command can only be issued up to and including $BL/2 - 1$ clock cycles after a READ or WRITE command. The effective burst length of a READ or WRITE command truncated by a BST command is as follows:

- Effective burst length = $2 \times$ (number of clock cycles from the READ or WRITE command to the BST command).
- If a READ or WRITE burst is truncated with a BST command, to calculate the minimum READ-to-WRITE or WRITE-to-READ delay, the effective burst length of the truncated burst should be used as the value for BL.
- The BST command only affects the most recent READ or WRITE command. The BST command truncates an ongoing READ burst $RL \times tCK + tDQSQ$ after the rising edge of the clock where the BST command is issued. The BST command truncates an on-going write burst $WL \times tCK + tDQSS$ after the rising edge of the clock where the BST command is issued.
- For LPDDR2-S4 devices, the 4-bit prefetch architecture enables BST command assertion on even clock cycles following a WRITE or READ command. The effective burst length of a READ or WRITE command truncated by a BST command is thus an integer multiple of 4.

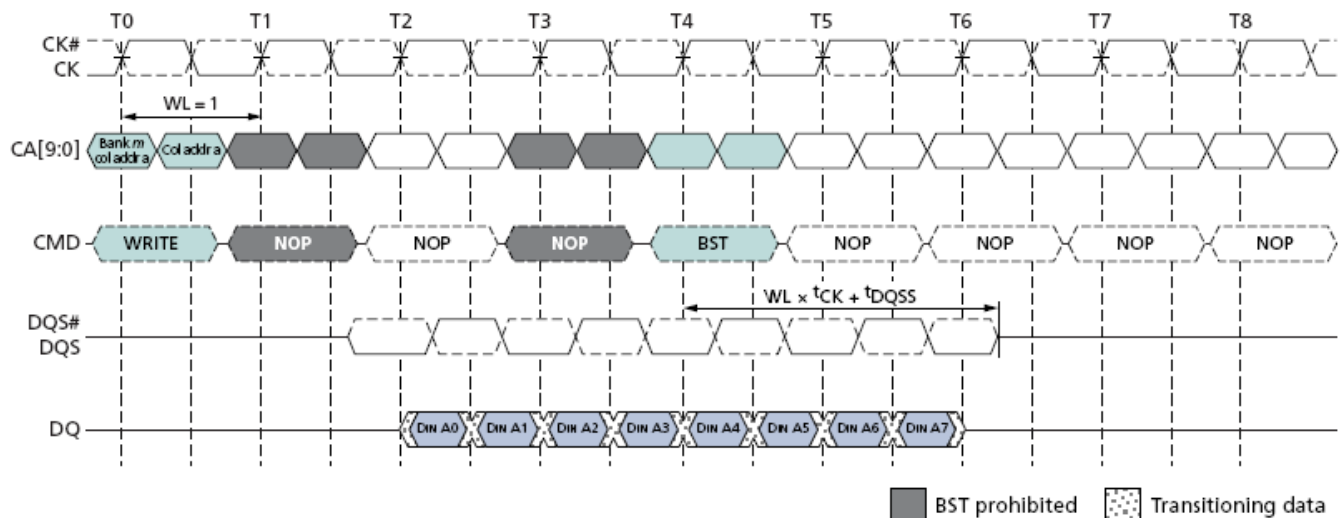

Burst Write truncated by BST: WL=1, BL=16

Notes:

1. The BST command truncates an ongoing write burst $WL * tCK + tDQSS$ after the rising edge of the clock where the Burst Terminate command is issued.
2. For LPDDR2-S4 devices, BST can only be issued an even number of clock cycles after the Write command.
3. Additional BST commands are not allowed after T4, and may not be issued until after the next Read or Write command.

Burst Terminate [BST] (Continued)

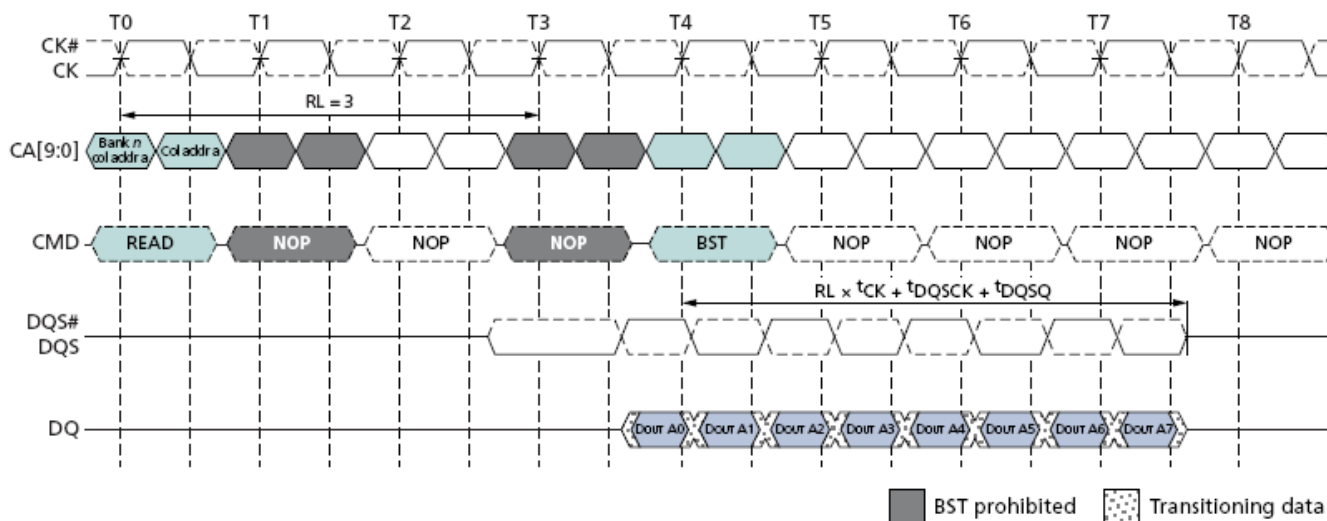

Burst Read truncated by BST: RL=3, BL=16

Notes:

1. The BST command truncates an ongoing read burst $RL \times t_{CK} + t_{DQCK} + t_{DQSQ}$ after the rising edge of the clock where the Burst Terminate command is issued.
2. For LPDDR2-S4 devices, BST can only be issued an even number of clock cycles after the Read command.
3. Additional BST commands are not allowed after T4, and may not be issued until after the next Read or Write command.

Write data Mask

One write data mask (DM) pin for each data byte (DQ) will be supported on LPDDR2 devices, consistent with the implementation on LPDDR SDRAMs. Each data mask (DM) may mask its respective data byte (DQ) for any given cycle of the burst. Data mask has identical timings on write operations as the data bits, though used as input only, is internally loaded identically to data bits to insure matched system timing.

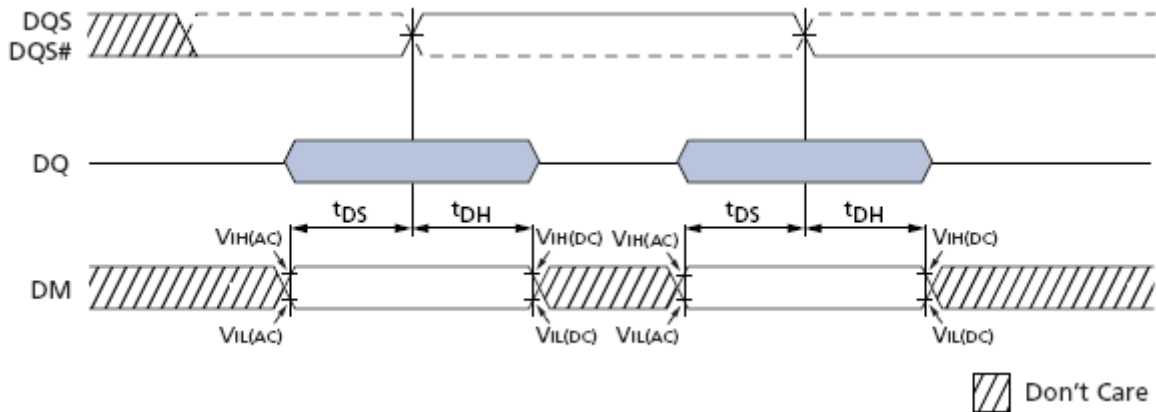

Data Mask Timing

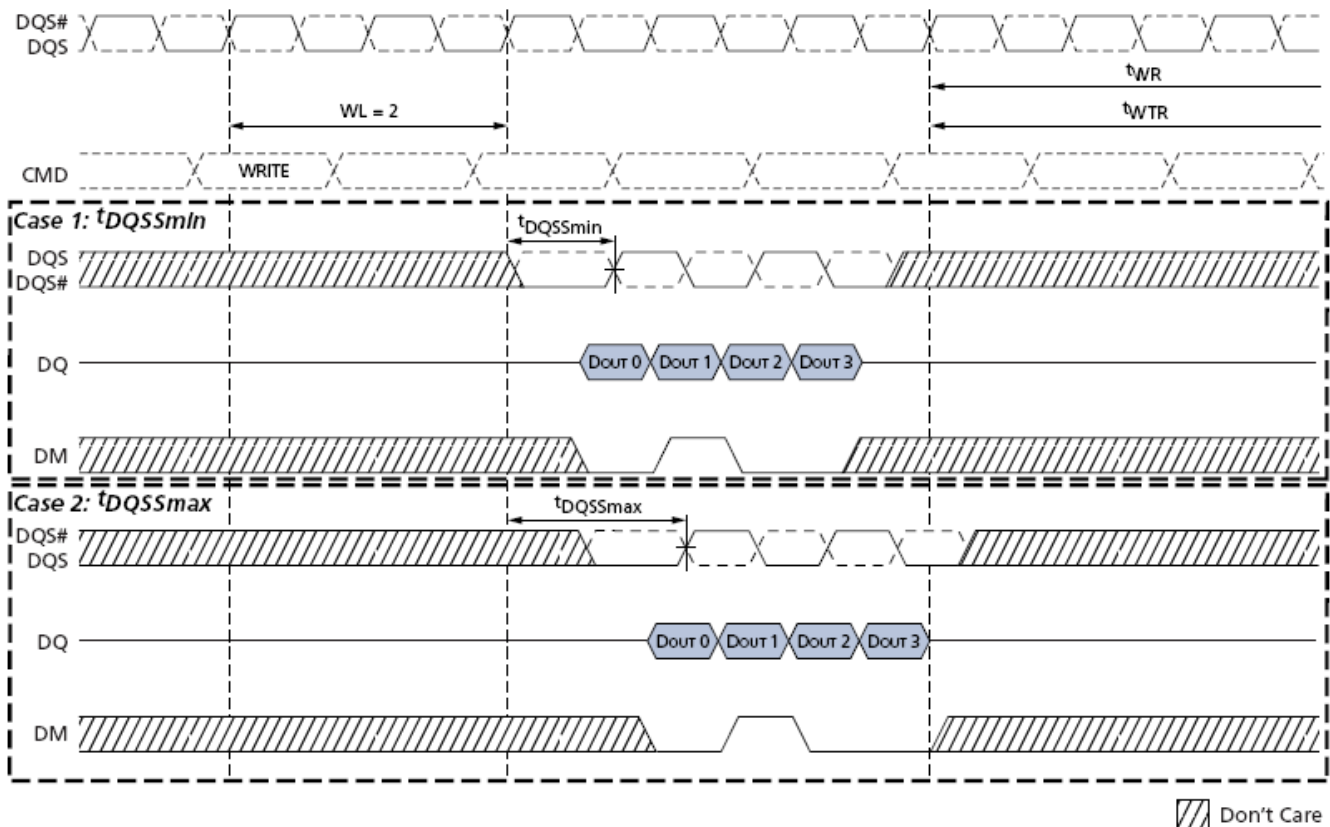

Write data mask: WL=2, BL=4, second DQ masked

Notes:

1. For the data mask function, WL=2, BL=4 is shown; the second data bit is masked.

Precharge

The Precharge command is used to precharge or close a bank that has been activated. The Precharge command is initiated by having CS_n LOW, CA0 HIGH, CA1 HIGH, CA2 LOW, and CA3 HIGH at the rising edge of the clock. The Precharge Command can be used to precharge each bank independently or all banks simultaneously. For 4-bank devices, the AB flag, and the bank address bits, BA0 and BA1, are used to determine which bank(s) to precharge. For 8-bank devices, the AB flag, and the bank address bits, BA0, BA1, and BA2, are used to determine which bank(s) to precharge. The bank(s) will be available for a subsequent row access ^tRP_{ab} after an All-Bank Precharge command is issued and ^tRP_{pb} after a Single-Bank Precharge command is issued.

In order to ensure that 8-bank devices do not exceed the instantaneous current supplying capability of 4-bank devices, the Row Precharge time (^tRP) for an All-Bank Precharge for 8-bank devices (^tRP_{ab}) will be longer than the Row Precharge time for a Single-Bank Precharge (^tRP_{pb}). For 4-bank devices, the Row Precharge time (^tRP) for an All-Bank Precharge (^tRP_{ab}) is equal to the Row Precharge time for a Single-Bank Precharge (^tRP_{pb}).

AB (CA4r)	BA2 (CA9r)	BA1 (CA8r)	BA0 (CA7r)	Precharged Bank(s) 4-bank device	Precharged Bank(s) 8-bank device
0	0	0	0	Bank 0 only	Bank 0 only
0	0	0	1	Bank 1 only	Bank 1 only
0	0	1	0	Bank 2 only	Bank 2 only
0	0	1	1	Bank 3 only	Bank 3 only
0	1	0	0	Bank 0 only	Bank 4 only
0	1	0	1	Bank 1 only	Bank 5 only
0	1	1	0	Bank 2 only	Bank 6 only
0	1	1	1	Bank 3 only	Bank 7 only
1	Don't care	Don't care	Don't care	All Banks	All Banks

Bank selection for Precharge by address bits

Burst Read followed by precharge

For the earliest possible precharge, the precharge command may be issued BL/2 clock cycles after a Read command. A new bank active (command) may be issued to the same bank after the Row Precharge time (t_{RP}). A precharge command can not be issued until after t_{RAS} is satisfied.

For LPDDR2-S4 devices, the minimum Read to Precharge spacing has also to satisfy a minimum analog time from the rising clock edge that initiates the last 4-bit precharge of a Read command. This time is called t_{RTP} (Read to Precharge). For LPDDR2-S4 devices, t_{RTP} begins BL/2 – 2 clock cycles after the Read command. If the burst is truncated by a BST command, the effective “BL” shall be used to calculate when t_{RTP} begins.

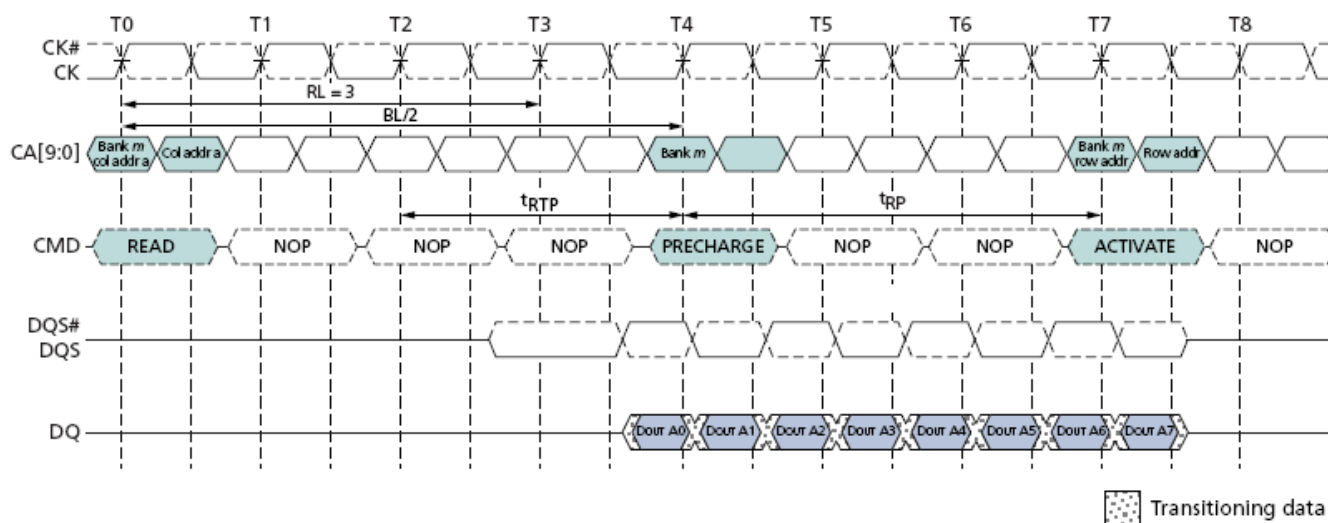

Burst Read followed by Precharge: RL=3, BL=8, $RU(t_{RTP(min)}/CK)=2$

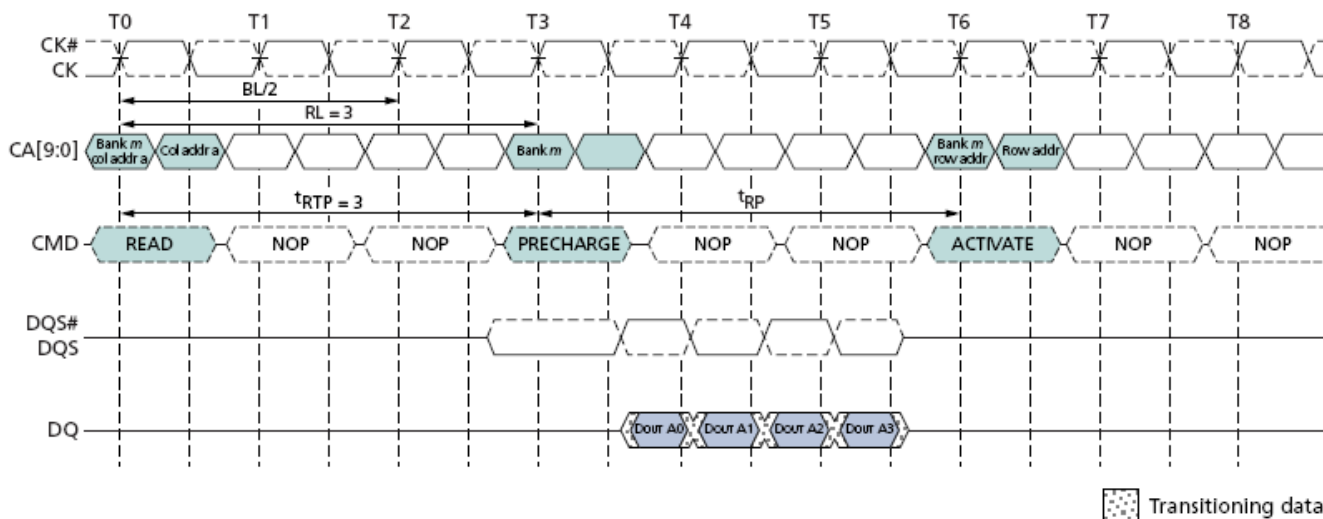

Burst Read followed by Precharge: RL=3, BL=4, $RU(t_{RTP(min)}/CK) = 3$

Burst Write followed by precharge

For write cycles, a delay must be satisfied from the time of the last valid burst input data until the Precharge command may be issued. This delay is known as the write recovery time (t_{WR}) referenced from the completion of the burst write to the Precharge command. No Precharge command to the same bank should be issued prior to the t_{WR} delay.

LPDDR2-S2 devices write data to the array in prefetch pairs (prefetch = 2) and LPDDR2-S4 devices write data to the array in prefetch quadruples (prefetch = 4). The beginning of an internal write operation may only begin after a prefetch group has been completely. Therefore, the write recovery time (t_{WR}) starts different boundaries for LPDDR2-S2 and LPDDR2-S4 devices.

For LPDDR2-S2 devices, minimum Write to Precharge command spacing to the same bank is $WL + RU(BL/2) + 1 + RU(t_{WR}/CK)$ clock cycles. For LPDDR2-S4 devices, minimum Write to Precharge command spacing to the same bank is $WL + BL/2 + 1 + RU(t_{WR}/CK)$ clock cycles. For an untruncated burst, BL is the value from the Mode Register. For a truncated burst, BL is the effective burst length.

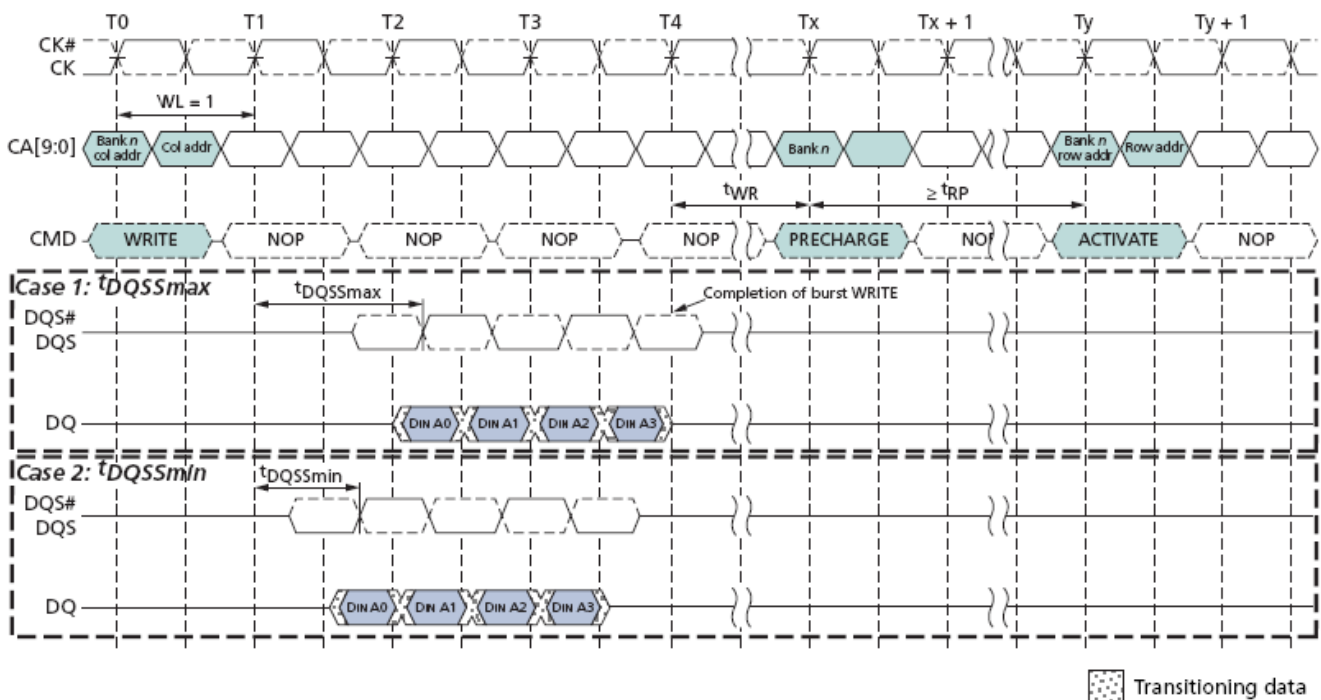

Burst Write followed by Precharge: WL=1, BL=4

Auto Precharge

Before a new row in an active bank can be opened, the active bank must be precharged using either the Precharge command or the auto-precharge function. When a Read or a Write command is given to the LPDDR2 SDRAM, the AP bit (CA0f) may be set to allow the active bank to automatically begin precharge at the earliest possible moment during the burst read or write cycle. If AP is LOW when the Read or Write command is issued, the normal Read or Write burst operation is executed and the bank remains active at the completion of the burst. If AP is HIGH when the Read or Write command is issued, then the auto-precharge function is engaged. This feature allows the precharge operation to be partially or completely hidden during burst read cycles (dependent upon Read or Write latency) thus improving system performance for random data access.

Burst Read with Auto Precharge

If AP (CA0f) is HIGH when a Read Command is issued, the Read with Auto-Precharge function is engaged. LPDDR2-S4 devices start an Auto-Precharge operation on the rising edge of the clock BL/2 or BL/2 – 2 + RU(^tRTP/^tCK) clock cycles later than the Read with AP command, whichever is greater.

A new bank Activate command may be issued to the same bank if both of the following two conditions are satisfied simultaneously:

- The RAS precharge time (^tRP) has been satisfied from the clock at which the auto-precharge begins.
- The RAS cycle time (^tRC) from the previous bank activation has been satisfied.

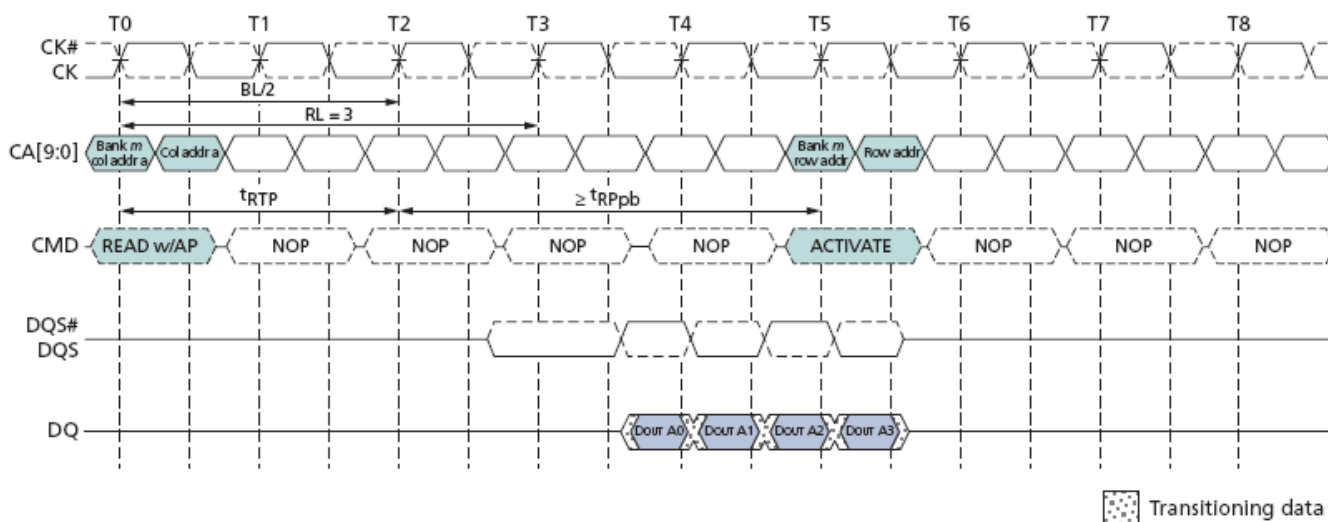

Burst Read with Auto-Precharge: RL=3, BL=4, RU(^tRTP(min)/^tCK)=2

Burst Write with Auto Precharge

If AP (CA0f) is HIGH when a Write Command is issued, the Write with Auto-Precharge function is engaged. The LPDDR2 SDRAM starts an Auto-precharge operation on the rising edge which is t_{WR} cycles after the completion of the burst write.

A new bank Activate command may be issued to the same bank if both of the following two conditions are satisfied:

- The RAS precharge time (t_{RP}) has been satisfied from the clock at which the auto-precharge begins.
- The RAS cycle time (t_{RC}) from the previous bank activation has been satisfied.

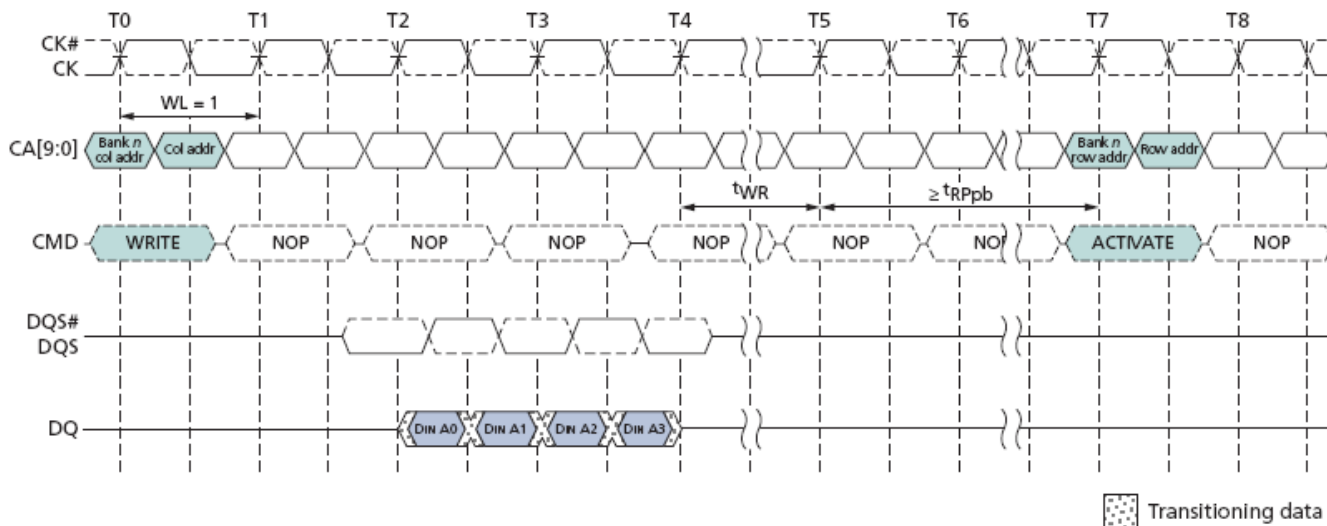

Burst Write with Auto-Precharge: WL=1, BL=4

LPDDR2-S4: Precharge & Auto Precharge clarification				
From Command	To Command	Minimum Delay between "From Command" to "To Command"	Unit	Notes
Read	Precharge (to same Bank as Read)	$BL/2 + \max(2, RU(^{t}RTP/^{t}CK)) - 2$	clks	1
	Precharge All	$BL/2 + \max(2, RU(^{t}RTP/^{t}CK)) - 2$	clks	1
BST (for Reads)	Precharge (to same Bank as Read)	1	clks	1
	Precharge All	1	clks	1
Read w/AP	Precharge (to same Bank as Read w/AP)	$BL/2 + \max(2, RU(^{t}RTP/^{t}CK)) - 2$	clks	1,2
	Precharge All	$BL/2 + \max(2, RU(^{t}RTP/^{t}CK)) - 2$	clks	1
	Activate (to same Bank as Read w/AP)	$BL/2 + \max(2, RU(^{t}RTP/^{t}CK)) - 2 + t_{RP}$	clks	1
	Write or Write w/AP (same bank)	illegal	clks	3
	Write or Write w/AP (different bank)	$RL + BL/2 + RU(^{t}DQSCkmax/^{t}CK) - WL + 1$	clks	3
	Read or Read w/AP (same bank)	illegal	clks	3
	Read or Read w/AP (different bank)	$BL/2$	clks	3
Write	Precharge (to same Bank as Write)	$WL + BL/2 + RU(^{t}WR/^{t}CK) + 1$	clks	1
	Precharge All	$WL + BL/2 + RU(^{t}WR/^{t}CK) + 1$	clks	1
BST (for Writes)	Precharge (to same Bank as Write)	$WL + RU(^{t}WR/^{t}CK) + 1$	clks	1
	Precharge All	$WL + RU(^{t}WR/^{t}CK) + 1$	clks	1
Write w/AP	Precharge (to same Bank as Write w/AP)	$WL + BL/2 + RU(^{t}WR/^{t}CK) + 1$	clks	1
	Precharge All	$WL + BL/2 + RU(^{t}WR/^{t}CK) + 1$	clks	1
	Activate (to same Bank as Write w/AP)	$WL + BL/2 + RU(^{t}WR/^{t}CK) + 1 + RU(^{t}RP_{pb}/^tCK)$	clks	1
	Write or Write w/AP (same bank)	illegal	clks	3
	Write or Write w/AP (different bank)	$BL/2$	clks	3
	Read or Read w/AP (same bank)	illegal	clks	3
	Read or Read w/AP (different bank)	$WL + BL/2 + RU(^{t}WTR/^{t}CK) + 1$	clks	3
Precharge	Precharge (to same Bank as Precharge)	1	clks	1
	Precharge All	1	clks	1
Precharge All	Precharge	1	clks	1
	Precharge All	1	clks	1

Notes:

1. For a given bank, the precharge period should be counted from the latest precharge command, either one bank precharge or precharge all, issued to that bank. The precharge period is satisfied after t_{RP} depending on the latest precharge command issued to that bank.
2. Any command issued during the minimum delay time as specified above table is illegal.
3. After Read with AP, seamless read operations to different banks are supported. After Write with AP, seamless write operations to different banks are supported. Read w/AP and Write a/AP may not be interrupted or truncated.

Refresh Command

The Refresh Command is initiated by having CS_n LOW, CA0 LOW, CA1 LOW, and CA2 HIGH at the rising edge of clock. Per Bank Refresh is initiated by having CA3 LOW at the rising edge of the clock and All Bank Refresh is initiated by having CA3 HIGH at the rising edge of clock. Per Bank Refresh is only allowed in devices with 8 banks.

A Per Bank Refresh Command, REFpb performs a refresh operation to the bank which is scheduled by the bank counter in the memory device. The bank sequence of Per Bank Refresh is fixed to be a sequential round-robin: "0-1-2-3-4-5-6-7-0-1-...". The bank count is synchronized between the controller and the SDRAM upon issuing a RESET command or at every exit from self refresh, by resetting bank count to zero. The bank addressing for the Per Bank Refresh count is the same as established in the single-bank Precharge command.

A bank must be idle before it can be refreshed. It is the responsibility of the controller to track the bank being refreshed by the Per Bank Refresh command. The REFpb command may not be issued to the memory until the following conditions are met:

- tRFCab has been satisfied after the prior REFab command.
- tRFCpb has been satisfied after the prior REFpb command.
- tRP has been satisfied after the prior Precharge command to that given bank.

tRRD has been satisfied after the prior ACTIVATE command (if applicable, for example after activating a row in a different bank than affected by the REFpb command). The target bank is inaccessible during the Per Bank Refresh cycle (tRFCpb), however other banks within the device are accessible and may be addressed during the Per Bank Refresh cycle. During the REFpb operation, any of the banks other than the one being refreshed can be maintained in active state or accessed by a read or a write command.

When the Per Bank Refresh cycle has completed, the affected bank will be in the idle state. As shown in the table, after issuing REFpb:

- tRFCpb must be satisfied before issuing a REFab command.
- tRFCpb must be satisfied before issuing an ACTIVE command to a same bank.
- tRRD must be satisfied before issuing an ACTIVE command to a different bank.
- tRFCpb must be satisfied before issuing another REFpb command.

An All Bank Refresh command, REFab performs a refresh operation to all banks. All banks have to be in idle state when REFab is issued (for instance, by Precharge All Bank command). REFab also synchronizes the bank count between the controller and the SDRAM to zero. As shown in the table, the REFab command may not be issued to the memory until the following conditions have been met:

- tRFCab has been satisfied after the prior REFab command.
- tRFCpb has been satisfied after the prior REFpb command.
- tRP has been satisfied after the prior Precharge commands.

When the All Bank Refresh cycle has completed, all banks will be in the idle state. As shown in the table, after issuing REFab:

- the tRFCab latency must be satisfied before issuing an ACTIVATE command.
- the tRFCab latency must be satisfied before issuing a REFab or REFpb command.

Command Scheduling Separations related to Refresh			
Symbol	minimum delay from	to	Notes
'RFC _{ab}	REF _{ab}	REF _{ab}	
		Activate cmd to <i>any</i> bank .	
		REF _{pb}	
'RFC _{pb}	REF _{pb}	REF _{ab}	
		Activate cmd to <i>same</i> bank as REF _{pb}	
		REF _{pb}	
'RRD	REF _{pb}	Activate cmd to <i>different</i> bank than REF _{pb}	
	Activate	REF _{pb} affecting an idle bank (different bank than Activate)	1
		Activate cmd to <i>different</i> bank than prior Activate	

Notes:

1. A bank must be in the idle state before it is refreshed. Therefore, after Activate, REF_{ab} is not allowed and REF_{pb} is allowed only if it affects a bank which is in the idle state.

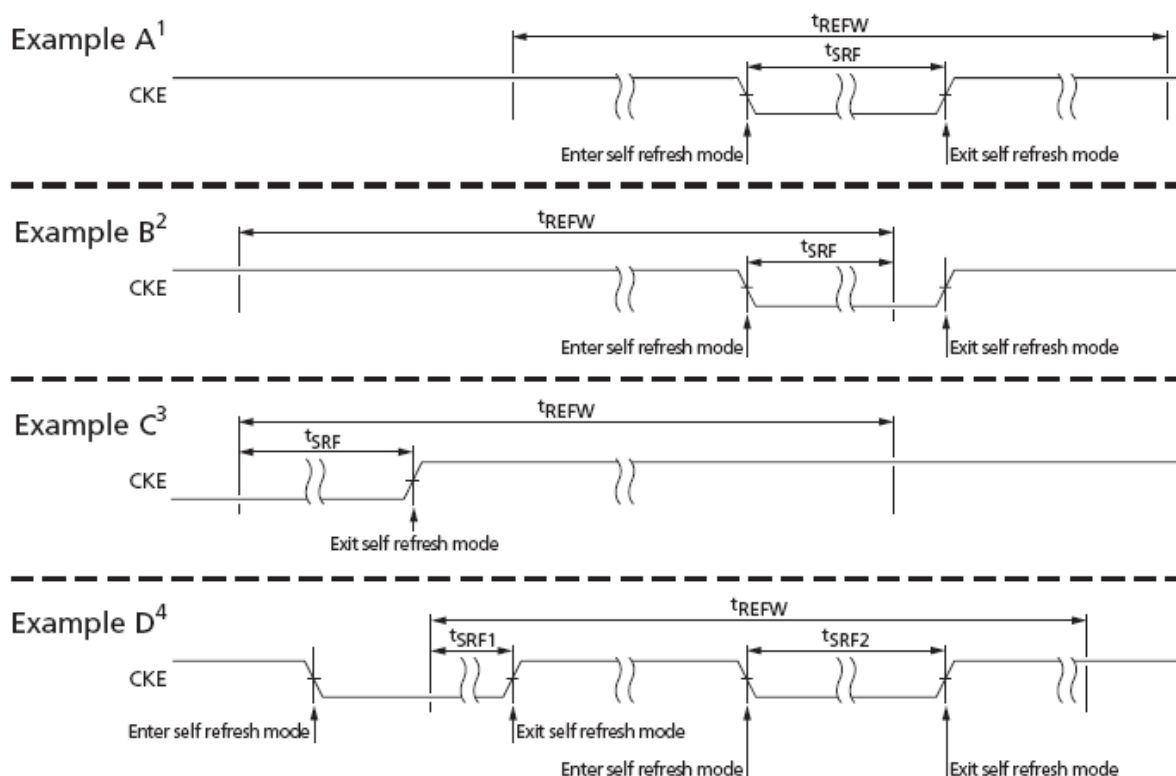

LPDDR2 S4: Definition of t_{SRF}

NOTE: Above examples are several cases on how t_{SRF} is calculated

1. (Example A): Time in self refresh mode is fully enclosed in the refresh window (t_{REFW})
2. (Example B): At self refresh entry.
3. (Example C): At self refresh exit.
4. (Example D): Several intervals in self refresh during one t_{REFW} interval. In this example, $t_{SRF} = t_{SRF1} + t_{SRF2}$.

Refresh Requirement (Continued)

The LPDDR2 devices provide significant flexibility in scheduling REFRESH commands as long as the boundary conditions are met. In the most straightforward implementations, a REFRESH command should be scheduled every t_{REFI} . In this case, self refresh can be entered at any time.

Users may choose to deviate from this regular refresh pattern, for example, to enable a period where no refreshes are required. In the extreme (e.g., LPDDR2-S4 1Gb), the user can choose to issue a refresh burst of 4096 REFRESH commands at the maximum supported rate (limited by t_{REFBW}), followed by an extended period without issuing any REFRESH commands, until the refresh window is complete. The maximum supported time without REFRESH commands is calculated as follows: $t_{REFW} - (R/8) \times t_{REFBW}$

= $t_{REFW} - R \times 4 \times t_{RFCab}$.

For example, a 1Gb LPDDR2-S4 device at $TC \leq 85^{\circ}C$ can be operated without REFRESH commands up to $32ms - 4096 \times 4 \times 130ns \approx 30ms$. Both the regular and the burst/pause patterns can satisfy refresh requirements if they are repeated in every 32ms window. It is critical to satisfy the refresh requirement in every rolling refresh window during refresh pattern transitions. The supported transition is from a burst pattern to a regular distributed pattern. If this transition occurs immediately after the burst refresh phase, all rolling t_{REFW} intervals will meet the minimum required number of refreshes.

A non-supported transition -In this example, the regular refresh pattern starts after the completion of the pause phase of the burst/pause refresh pattern. For several rolling t_{REFW} intervals, the minimum number of REFRESH commands is not satisfied.

Understanding this pattern transition is extremely important, even when only one pattern is employed. In self refresh mode, a regular distributed-refresh pattern must be assumed. It is recommended entering self refresh mode immediately following the burst phase of a burst/pause refresh pattern; upon exiting self refresh, begin with the burst phase.

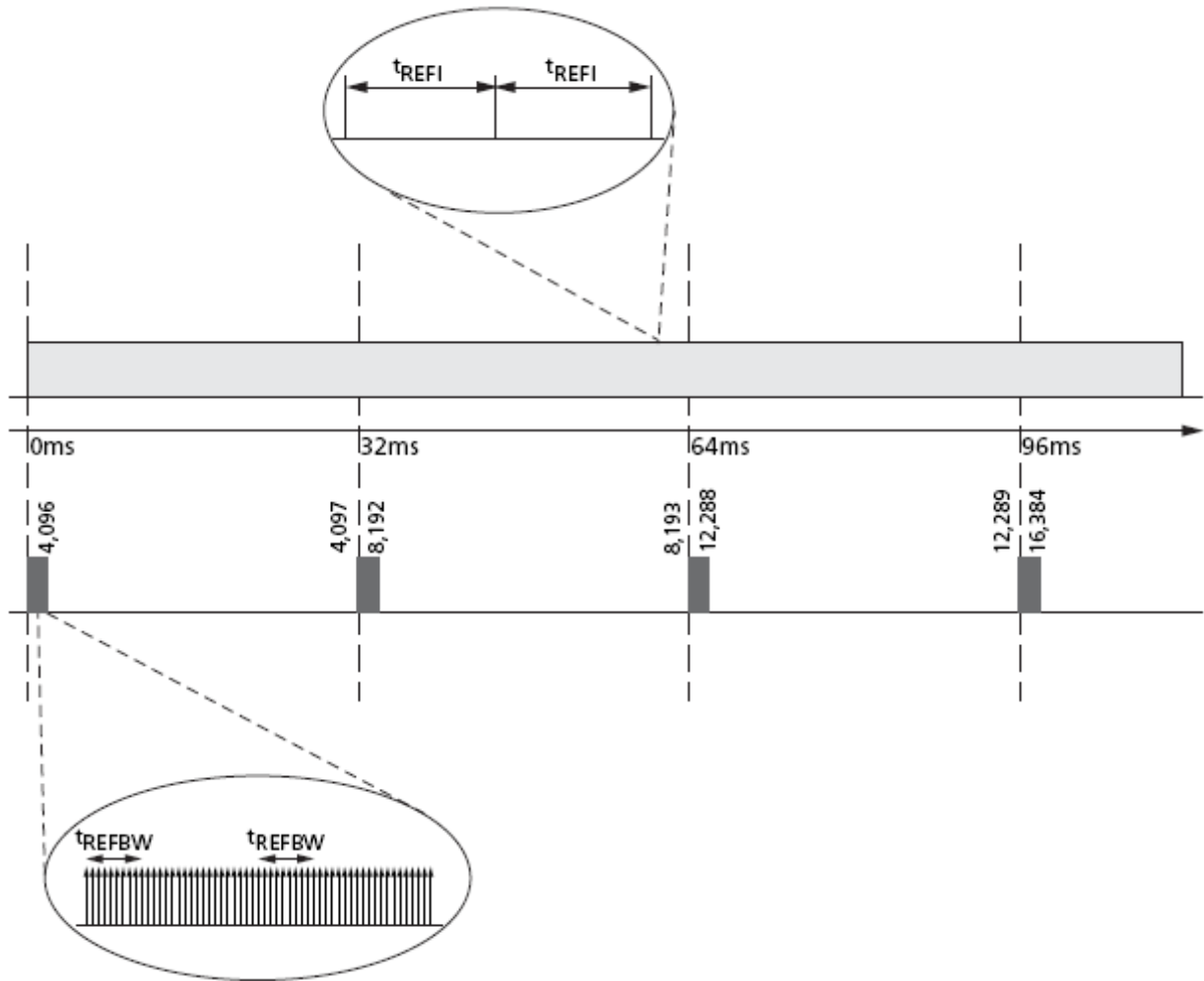

Regular, Distributed REFRESH Pattern

Notes:

1. Compared to repetitive burst REFRESH with subsequent REFRESH pause.
2. As an example, in a 1Gb LPDDR2-S4 device at $TC \leq 85^{\circ}C$, the distributed refresh pattern has one REFRESH command per $7.8\mu s$; the burst refresh pattern has one refresh command per $0.52\mu s$, followed by $\approx 30ms$ without any REFRESH command.

Refresh Requirement (Continued)

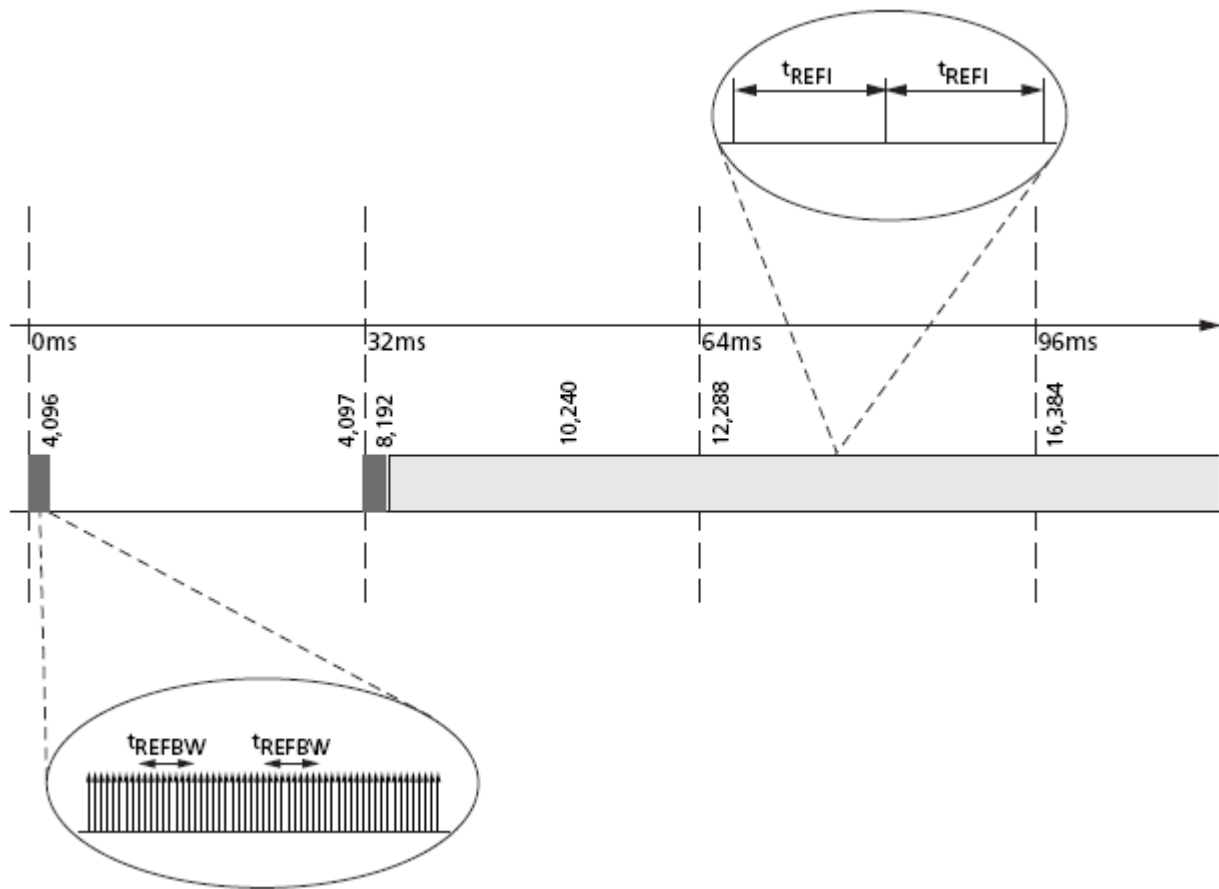

Supported Transition from Repetitive Burst REFRESH

Notes:

1. Shown with subsequent REFRESH pause to regular, distributed-refresh pattern.
2. As an example, in a 1Gb LPDDR2-S4 device at $TC \leq 85^\circ C$, the distributed refresh pattern has one REFRESH command per $7.8\mu s$; the burst refresh pattern has one refresh command per $0.52\mu s$, followed by $\approx 30ms$ without any REFRESH command.

Refresh Requirement (Continued)

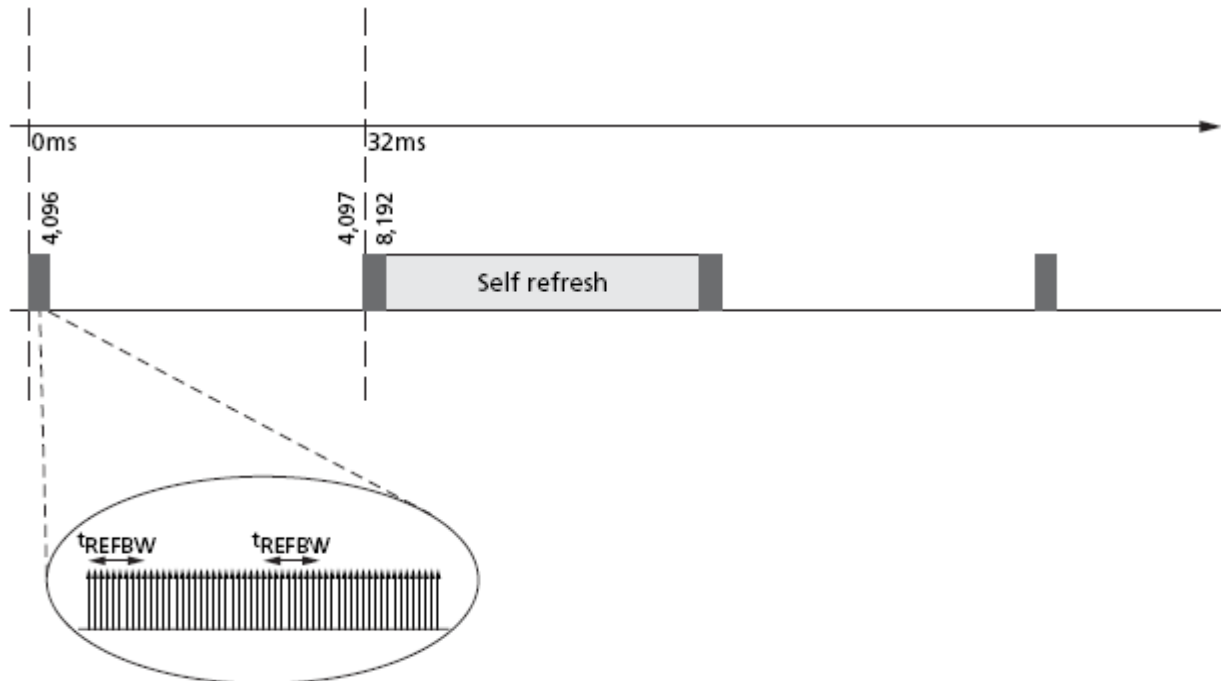

Recommended Self Refresh Entry and Exit

Notes:

1. In conjunction with a burst/pause refresh pattern.

Refresh Requirement (Continued)

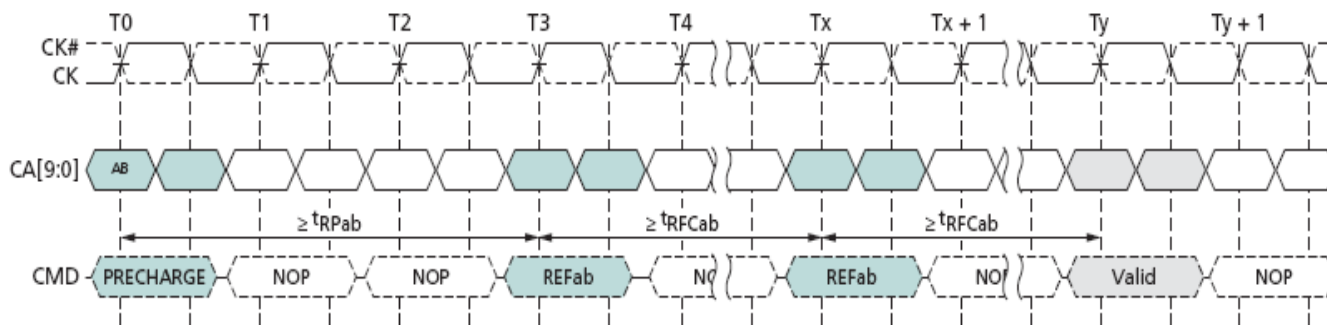

All Bank Refresh Operation

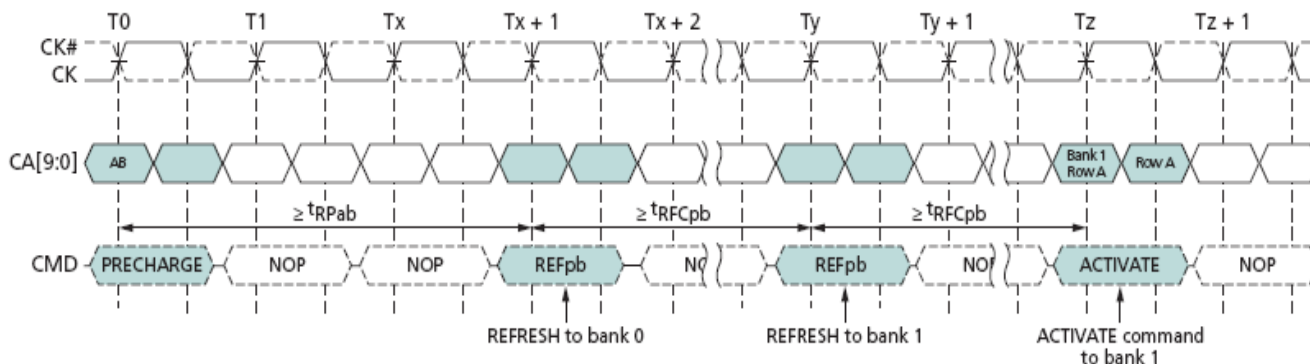

Per-Bank Refresh Operation

Notes:

1. In the beginning of this example, the REFpb bank is pointing to Bank 0.
2. Operations to other banks than the bank being refreshed are allowed during the tREFpb period.

Self Refresh Operation

The Self Refresh command can be used to retain data in the LPDDR2 SDRAM, even if the rest of the system is powered down. When in the Self Refresh mode, the LPDDR2 SDRAM retains data without external clocking. The LPDDR2 SDRAM device has a built-in timer to accommodate Self Refresh operation. The Self Refresh Command is defined by having CKE LOW, CS_n LOW, CA0 LOW, CA1 LOW, and CA2 HIGH at the rising edge of the clock. CKE must be HIGH during the previous clock cycle. A NOP command must be driven in the clock cycle following the power-down command. Once the command is registered, CKE must be held LOW to keep the device in Self Refresh mode.

LPDDR2-S4 devices can operate in Self Refresh in both the Standard or Extended Temperature Ranges. LPDDR2-S4 devices will also manage Self Refresh power consumption when the operating temperature changes, lower at low temperature and higher at high temperature.

Once the LPDDR2 SDRAM has entered Self Refresh mode, all of the external signals except CKE, are “don’t care”. For proper self refresh operation, power supply pins (VDD1, VDD2, and VDDCA) must be at valid levels. VDDQ may be turned off during Self-Refresh. Prior to exiting Self-Refresh, VDDQ must be within specified limits. VrefQD and VrefCA may be at any level within minimum and maximum levels. However prior to exiting Self-Refresh, VrefDQ and VrefCA must be within specified limits. The SDRAM initiates a minimum of one all-bank refresh command internally within tCKESR period, once it enters Self Refresh mode. The clock is internally disabled during Self Refresh Operation to save power. The minimum time that the LPDDR2 SDRAM must remain in Self Refresh mode is tCKESR. The user may change the external clock frequency or halt the external clock one clock after Self Refresh entry is registered; however, the clock must be restarted and stable before the device can exit Self Refresh operation.

The procedure for exiting Self Refresh requires a sequence of commands. First, the clock shall be stable and within specified limits for a minimum of 2 clock cycles prior to CKE going back HIGH. Once Self Refresh Exit is registered, a delay of at least tXSR must be satisfied before a valid command can be issued to the device to allow for any internal refresh in progress. CKE must remain HIGH for the entire Self Refresh exit period tXSR for proper operation except for self refresh re-entry. NOP commands must be registered on each positive clock edge during the Self Refresh exit interval tXSR.

The use of Self Refresh mode introduces the possibility that an internally timed refresh event can be missed when CKE is raised for exit from Self Refresh mode. Upon exit from Self Refresh, it is required that at least one Refresh command (8 per-bank or 1 all-bank) is issued before entry into a subsequent Self Refresh.

Self Refresh Operation (Continued)

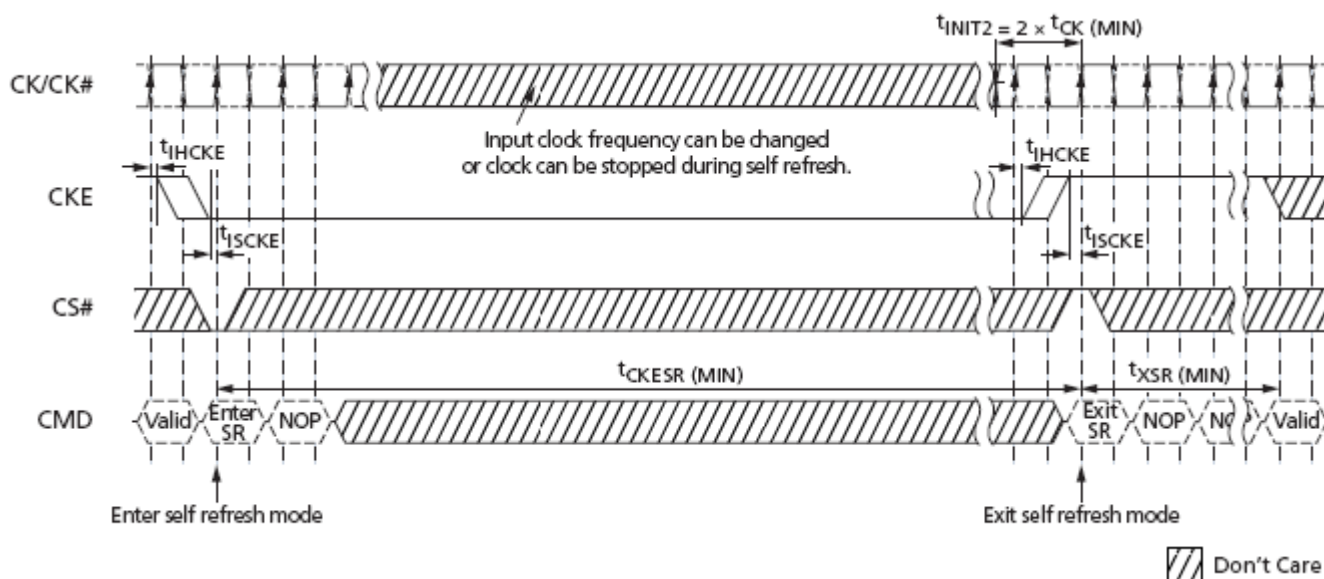

Self Refresh Operation

Notes:

1. Input clock frequency may be changed or stopped during self-refresh, provided that upon exiting self-refresh, a minimum of 2 clocks (t_{INIT2}) of stable clock are provided and the clock frequency is between the minimum and maximum frequency for the particular speed grade.
2. Device must be in the "All banks idle" state prior to entering Self Refresh mode.
3. t_{XSR} begins at the rising edge of the clock after CKE is driven HIGH.
4. A valid command may be issued only after t_{XSR} is satisfied. NOPs shall be issued during t_{XSR} .

Partial Array Self-Refresh: Bank Masking

LPDDR2-S4 SDRAM has 4 or 8 banks. For LPDDR2-S4 devices, 64Mb to 512Mb LPDDR2 SDRAM has 4 banks, while 1Gb and higher density has 8. Each bank of LPDDR2 SDRAM can be independently configured whether a self refresh operation is taking place. One mode register unit of 8 bits accessible via MRW command is assigned to program the bank masking status of each bank up to 8 banks. For bank masking bit assignments, see Mode Register 16.

The mask bit to the bank controls a refresh operation of entire memory within the bank. If a bank is masked via MRW, a refresh operation to entire bank is not blocked and data retention by a bank is not guaranteed in self refresh mode. To enable a refresh operation to a bank, a coupled mask bit has to be programmed, "unmasked". When a bank mask bit is unmasked, the array space being refreshed within that bank is determinate by the programmed status of the segment mask bit.

Partial Array Self-Refresh: Segment Masking

Segment Programming segment mask bits is similar to programming bank mask bits. For densities 1Gb and higher, 8 segments are used for masking. Mode register 17 is used for programming segment mask bits up to 8 bits. For densities less than 1Gb, segment masking is not supported.

When the mask bit to an address range (represented as a segment) is programmed as “masked,” a REFRESH operation to that segment is blocked. Conversely, when a segment mask bit to an address range is unmasked, refresh to that segment is enabled. A segment-masking scheme can be used in place of or in combination with a bank masking scheme in LPDDR2-S4 SDRAM. Each segment-mask bit setting is applied across all banks.

	Segment Mask (MR17)	Bank 0	Bank 1	Bank 2	Bank 3	Bank 4	Bank 5	Bank 6	Bank 7
Bank Mask (MR16)		0	1	0	0	0	0	0	1
Segment 0	0		M						M
Segment 1	0		M						M
Segment 2	1	M	M	M	M	M	M	M	M
Segment 3	0		M						M
Segment 4	0		M						M
Segment 5	0		M						M
Segment 6	0		M						M
Segment 7	1	M	M	M	M	M	M	M	M

Example of Bank and Segment Masking use in LPDDR2-S4 devices

Notes:

1. This table illustrates an example of an 8-bank LPDDR2-S4 device, when a refresh operation to bank 1 and bank 7, as well as segment 2 and segment 7 are masked.

Mode Register Read Command

The Mode Register Read command is used to read configuration and status data from mode registers for LPDDR SDRAM. The Mode Register Read (MRR) command is initiated by having CS_n LOW, CA0 LOW, CA1 LOW, CA2 LOW, and CA3 HIGH at the rising edge of the clock. The mode register is selected by {CA1f-CA0f, CA9r-CA4r}. The mode register contents are available on the first data beat of DQ0-DQ7, RL * tCK + tDQSCK + tDQSQ after the rising edge of the clock where the Mode Register Read Command is issued. Subsequent data beats contain valid, but undefined content, except in the case of the DQ Calibration function DQC, where subsequent data beats contain valid content as described in “DQ Calibration”. All DQS shall be toggled for the duration of the Mode Register Read burst. The MRR command has a burst length of four. The Mode Register Read operation (consisting of the MRR command and the corresponding data traffic) shall not be interrupted. The MRR command period (tMRR) is 2 clock cycles. Mode Register Reads to reserved and write-only registers shall return valid, but undefined content on all data beats and DQS shall be toggled.

Mode Register Read Command (Continued)

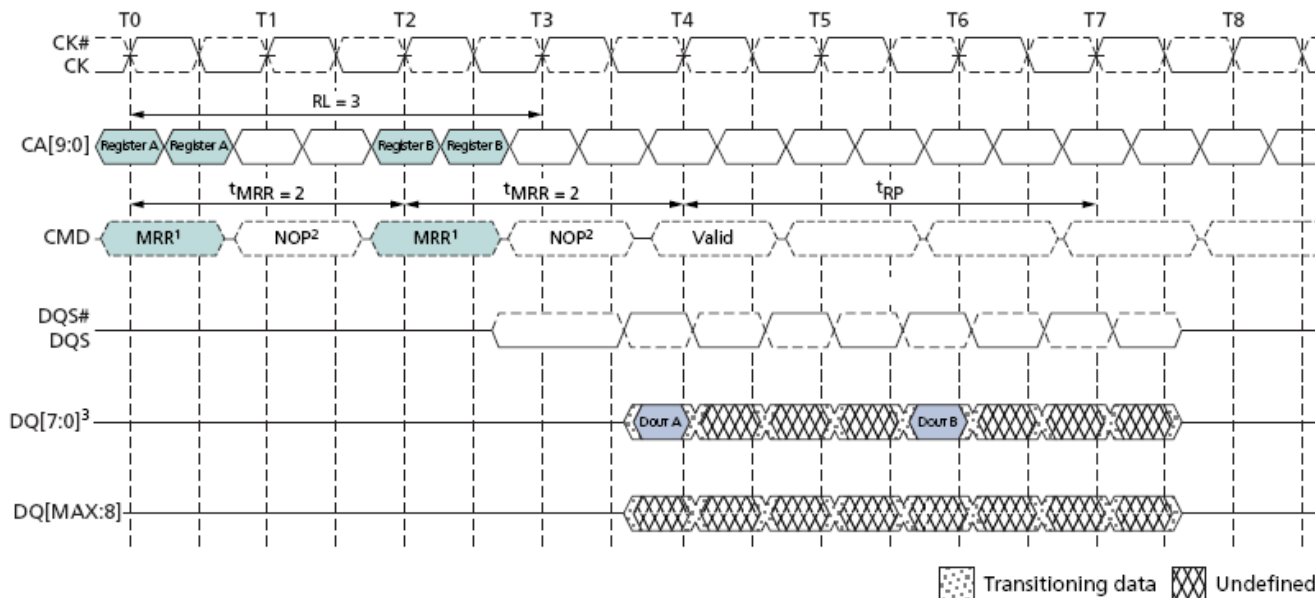

Mode Register Read timing example: RL=3, tMRR=2

Notes:

1. Mode Register Read has a burst length of four
2. Mode Register Read operation shall not be interrupted
3. MRRs to DQ calibration registers MR32 and MR40 are described in "DQ Calibration".
4. Only the NOP command is supported during tMRR.
5. Mode register data is valid only on DQ[7:0] on the first beat. Subsequent beats contain valid but undefined data. DQ[MAX:8] contain valid but undefined data for the duration of the MRR burst.
6. Minimum Mode Register Read to write latency is $RL+RU(tDQSCK,max/tCK)+4/2+1-WL$ clock cycles
7. Minimum Mode Register Read to Mode Register Write Latency is $RL+RU(tDQSCK,max/tCK)+4/2+1$ clock cycles

After a prior READ command, the MRR command must not be issued earlier than $BL/2$ clock cycles, or $WL + 1 + BL/2 + RU(tWTR/tCK)$ clock cycles after a prior WRITE command, as READ bursts and WRITE bursts must not be truncated by MRR. Note that if a READ or WRITE burst is truncated with a BST command, the effective burst length of the truncated burst should be used for the value BL.

Temperature Sensor

LPDDR2 devices feature a temperature sensor whose status can be read from MR4. This sensor can be used to determine an appropriate refresh rate, determine whether AC timing derating is required in the extended temperature range, and/or monitor the operating temperature. Either the temperature sensor or the device operating temperature can be used to determine if operating temperature requirements are being met.

Temperature sensor data may be read from MR4 using the Mode Register Read protocol.

When using the temperature sensor, the actual device case temperature may be higher than the operating temperature specification that applies for the standard or extended temperature ranges. For example, TCASE could be above 85°C when MR4[2:0] equals 011B.

To assure proper operation using the temperature sensor, applications must accommodate the specifications shown in bellow.

Temperature Sensor Definitions and Operating Considerations

Parameter	Symbol	Max/Min	Value	Unit	Notes
System Temperature Gradient	TempGradient	Max	System Dependent	C/s	Maximum temperature gradient experienced by the memory device at the temperature of interest over a range of 2°C.
MR4 Read Interval	ReadInterval	Max	System Dependent	ms	Time period between MR4 READs from the system.
Temperature Sensor Interval	^t TSI	Max	32	ms	Maximum delay between internal updates of
System Response Delay	SysRespDelay	Max	System Dependent	ms	Maximum response time from an MR4 READ to the system response.
Device Temperature Margin	TempMargin	Max	2	C	Margin above maximum temperature to support controller response.

These devices accommodate the 2 degree Celsius temperature margin between the point at which the device temperature enters the extended temperature range and point at which the controller re-configures the system accordingly. To determine the required MR4 polling frequency, the system must use the maximum TempGradient and the maximum response time of the system using the following equation:

$$TempGradient \times (ReadInterval + {}^tTSI + SysRespDelay) \leq 2^\circ C$$

For example, if TempGradient is 10°C/s and the SysRespDelay is 1ms:

$$\frac{10^\circ C}{s} \times (ReadInterval + 16ms + 1ms) \leq 2^\circ C$$

In this case, ReadInterval must not exceed 183ms

Temperature Sensor (Continued)

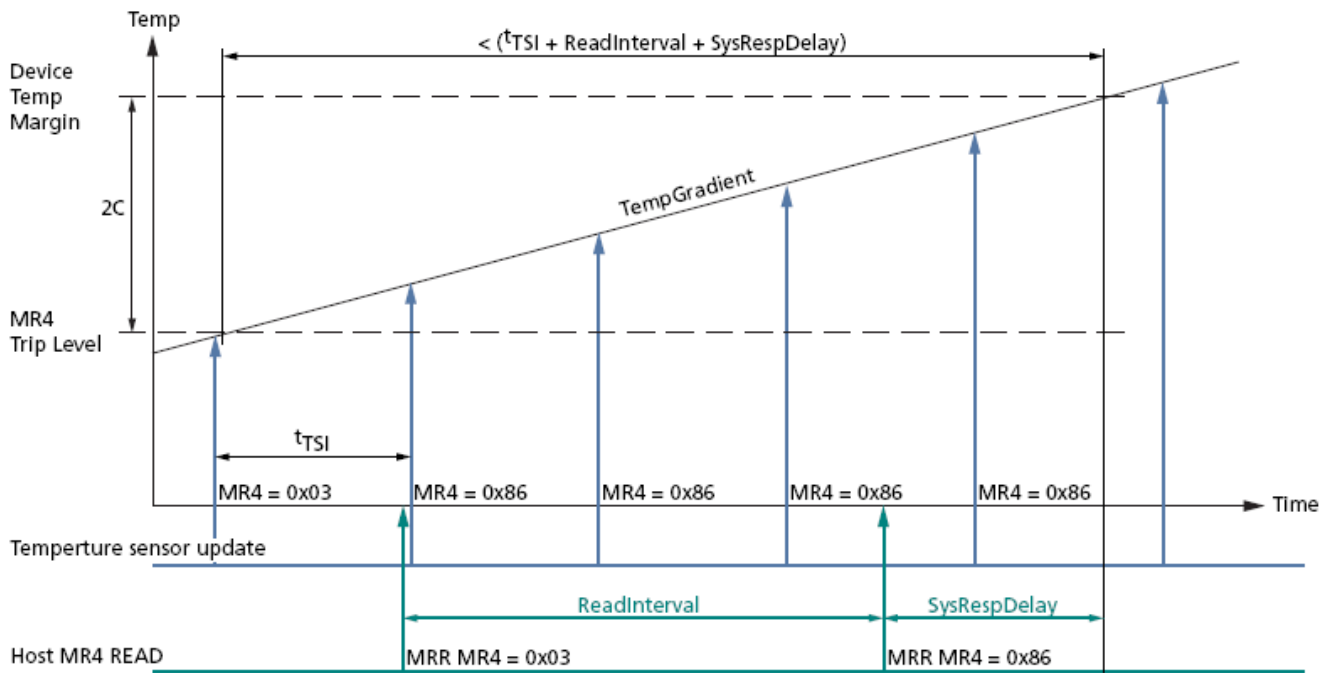

Temp Sensor Timing

DQ Calibration

LPDDR2 devices feature a DQ calibration function that outputs one of two predefined system-timing calibration patterns. MRR to MR32 (pattern A) or MRR to MR40 (pattern B) will return the specified pattern on DQ0 and DQ8 for x16 devices and DQ0, DQ8, DQ16, and DQ24 for x32 devices. For x16 devices, DQ[7:1] and DQ[15:9] drive the same information as DQ0 during the MRR burst. For x32 devices, DQ[7:1], DQ[15:9], DQ[23:17], and DQ[31:25] drive the same information as DQ0 during the MRR burst. MRR DQ calibration commands can occur only in the idle state.

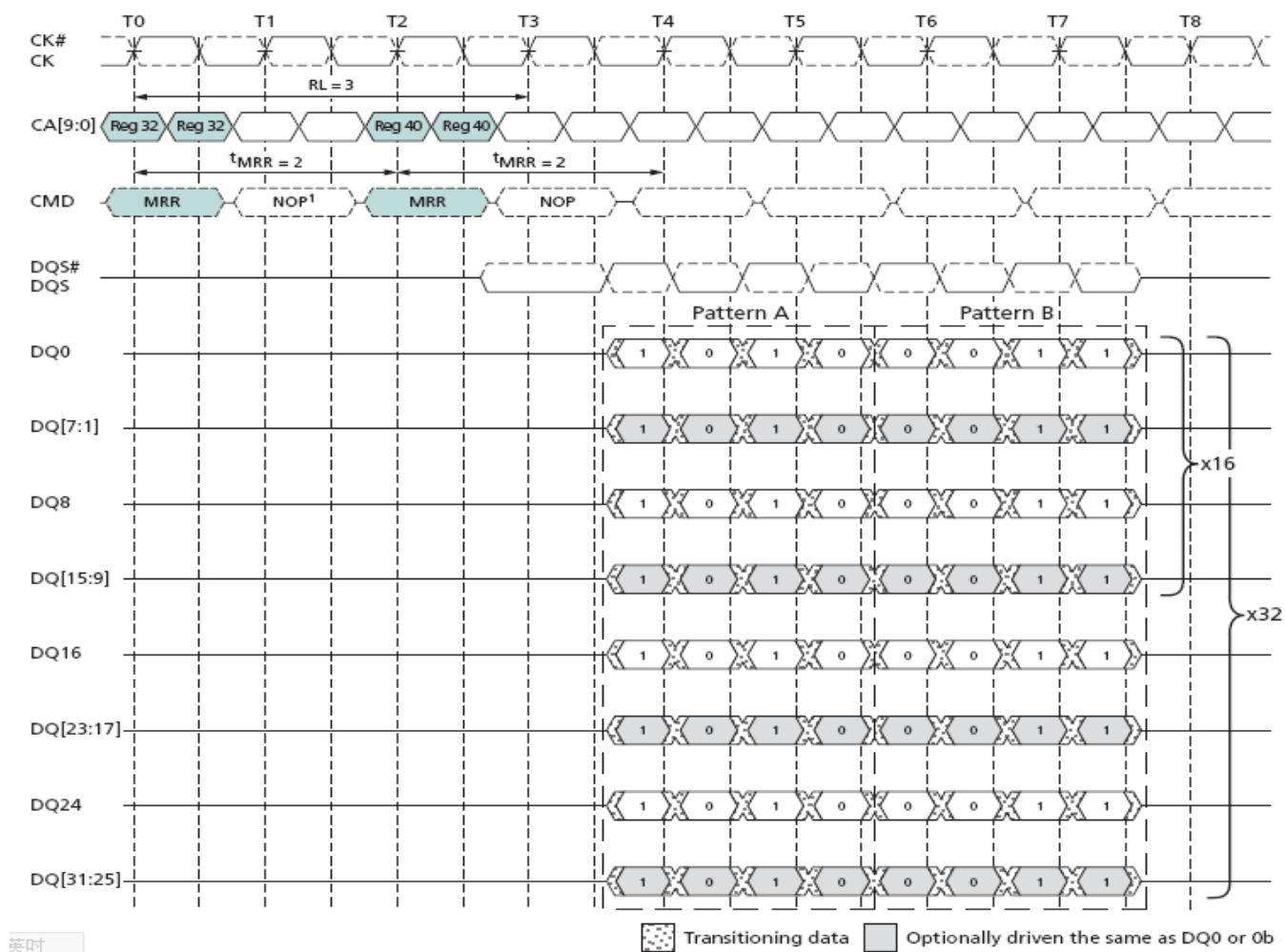

DQ MR32 and MR40 DQ Calibration timing, example: $RL=3$, $t_{MRR}=2$

Notes: Only the NOP command is supported during t_{MRR} . Mode Register Read has BL4 and shall not be interrupted

Data Calibration Pattern Description

Pattern	MR#	Bit	Tim	Bi0	Tim	Bi1	Tim	Bi2	Time	3	Notes
Pattern	MR 32	1		0		1		0			Reads to MR32 return DQ callib
Pattern	MR 40	0		0		1		1			Reads to MR32 return DQ callib

Mode Register Write (MRW)

The MRW command is used to write configuration data to mode registers. The MRW command is initiated with \overline{CS} LOW, CA0 LOW, CA1 LOW, CA2 LOW, and CA3 LOW at the rising edge of the clock. The mode register is selected by CA1f-CA0f, CA9f-CA4f. The data to be written to the mode register is contained in CA9f-CA2f. The MRW command period is defined by tMRW. Mode register WRITES to read-only registers have no impact on the functionality of the device.

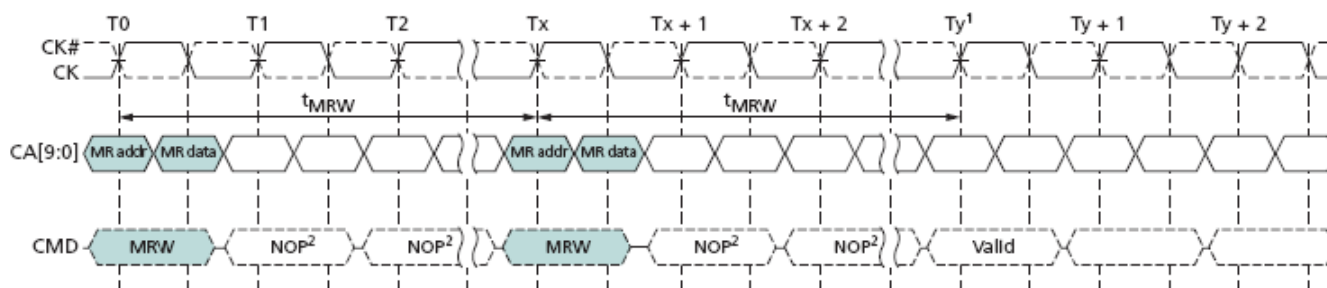

Mode Register Write timing, example: RL=3, tMRW=5

Notes:

1. Only the NOP command is supported during tMRW.
2. At time Ty, the device is in the idle state.

The MRW can only be issued when all banks are in the idle precharge state. One method of ensuring that the banks are in this state is to issue a PRECHARGE-ALL command.

Current State	Command	Intermediate State	Next State
All Banks idle	MRR	Mode Register Reading (All Banks idle)	All Banks idle
	MRW	Mode Register Writing (All Banks idle)	All Banks idle
	MRW (Reset)	Resting (Device Auto-Init)	All Banks idle
Bank(s) Active	MRR	Mode Register Reading (Bank(s) idle)	Bank(s) Active
	MRW	Not Allowed	Not Allowed
	MRW (Reset)	Not Allowed	Not Allowed

Truth Table for Mode Register Read (MRR) and Mode Register Write (MRW)

Mode Register Write Reset (MRW Reset)

The MRW RESET command brings the device to the device auto-initialization (resetting) state in the power-on initialization sequence. The MRW RESET command can be issued from the idle state. This command resets all mode registers to their default values. Only the NOP command is supported during tINIT4. After MRW RESET, boot timings must be observed until the device initialization sequence is complete and the device is in the idle state. Array data is undefined after the MRW RESET command.

Mode Register Write ZQ Calibration command

The MRW command is used to initiate the ZQ calibration command. This command is used to calibrate the output driver impedance across process, temperature, and voltage. LPDDR2-S4 devices support ZQ calibration.

There are four ZQ calibration commands and related timings: tZQINIT, tZQRESET, tZQCL, and tZQCS. tZQINIT is for initialization calibration; tZQRESET is for resetting ZQ to the default output impedance; tZQCL is for long calibration(s); and tZQCS is for short calibration(s).

The initialization ZQ calibration (ZQINIT) must be performed for LPDDR2-S4. ZQINIT provides an output impedance accuracy of ±15 percent. After initialization, the ZQ calibration long (ZQCL) can be used to recalibrate the system to an output impedance accuracy of ±15 percent. A ZQ calibration short (ZQCS) can be used periodically to compensate for temperature and voltage drift in the system.

The ZQ reset command (ZQRESET) resets the output impedance calibration to a default accuracy of ±30% across process, voltage, and temperature. This command is used to ensure output impedance accuracy to ±30% when ZQCS and ZQCL commands are not used.

One ZQCS command can effectively correct at least 1.5% (ZQ correction) of output impedance errors within tZQCS for all speed bins, assuming the maximum sensitivities specified are met. The appropriate interval between ZQCS commands can be determined from using these tables and system-specific parameters.

LPDDR2 devices are subject to temperature drift rate (TdriftrateE) and voltage drift rate (Vdriftrate) in various applications. To accommodate drift rates and calculate the necessary interval between ZQCS commands, apply the following formula:

$$\frac{ZQ_{correction}}{(T_{sens} \times T_{driftrate}) + (V_{sens} \times V_{driftrate})}$$

where Tsens = max(dRONdT) and Vsens = max(dRONdV), define the LPDDR2 temperature and voltage sensitivities.

For example, if Tsens = 0.75% / C, Vsens = 0.20% / mV, Tdriftrate = 1 C / sec and Vdriftrate = 15 mV / sec, then the interval between ZQCS commands is calculated as:

$$\frac{1.5}{(0.75 \times 1) + (0.20 \times 15)} = 0.4s$$

For LPDDR2-S4 devices, a ZQ Calibration command may only be issued when the device is in Idle state with all banks precharged. No other activities can be performed on the LPDDR2 data bus during the calibration period (tZQINIT, tZQCL, tZQCS).

The quiet time on the LPDDR2 data bus helps to accurately calibrate RON. There is no required quiet time after the ZQ Reset command. If multiple devices share a single ZQ Resistor, only one device may be calibrating at any given time. After calibration is achieved, the LPDDR2 device shall disable the ZQ ball's current consumption path to reduce power.

In systems that share the ZQ resistor between devices, the controller must not allow overlap of t_{ZQINIT} , t_{ZQCS} , or t_{ZQCL} between the devices. ZQ Reset overlap is allowed. If the ZQ resistor is absent from the system, ZQ shall be connected

Mode Register Write ZQ Calibration command (Continued)

permanently to VDDCA. In this case, the LPDDR2 shall ignore ZQ calibration commands and the device will use the default calibration settings.

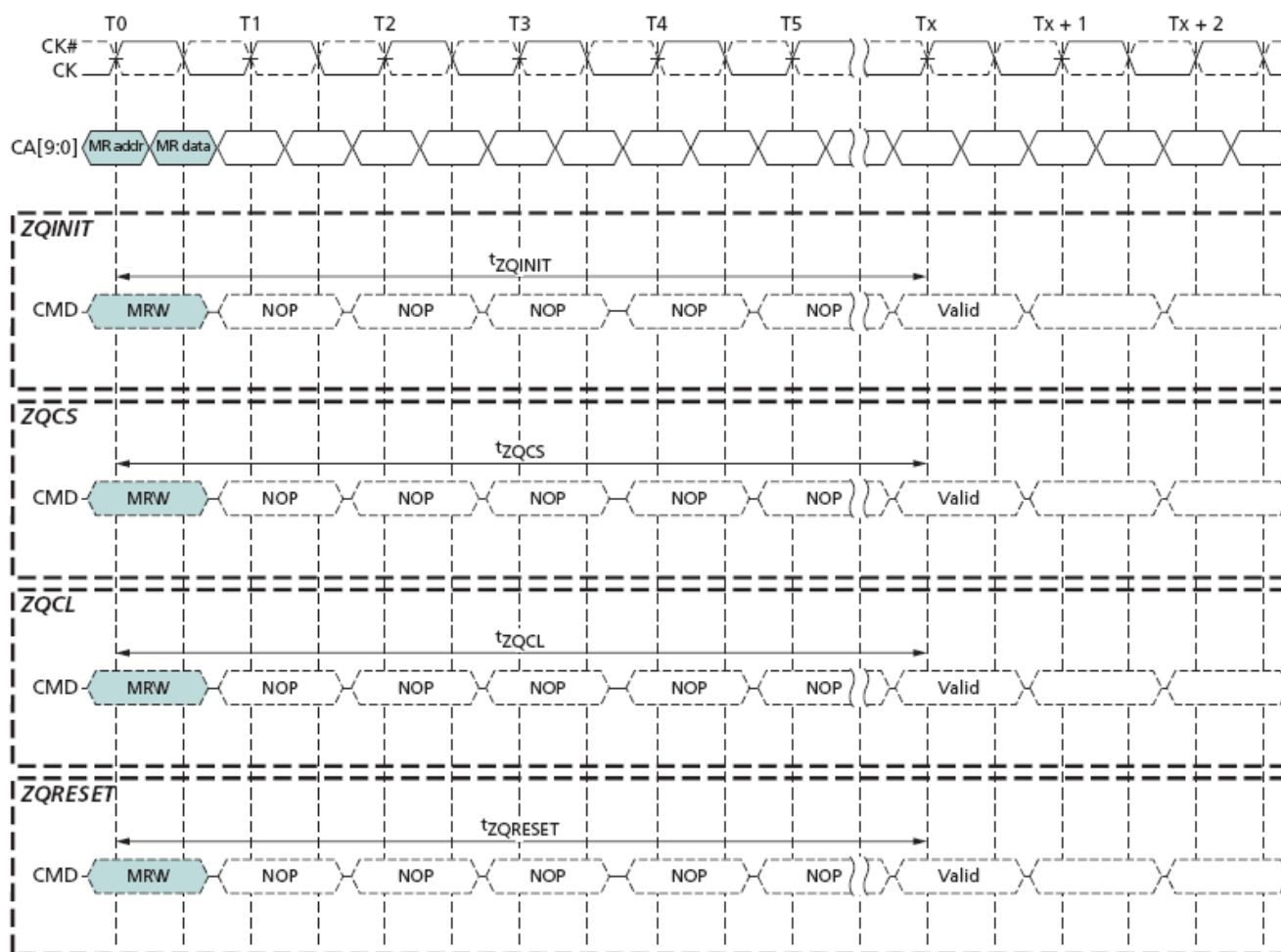

ZQ Calibration Initialization timing example

Notes:

1. Only the NOP command is supported during ZQ calibration.
2. CKE must be registered HIGH continuously during the calibration period.
3. All devices connected to the DQ bus should be High-Z during the calibration process.

ZQ External Resistor Value, Tolerance and Capacitive Loading

To use the ZQ Calibration function, a 240 Ohm +/- 1% tolerance external resistor must be connected between the ZQ pin and ground. A single resistor can be used for each LPDDR2 device or one resistor can be shared between multiple LPDDR2 devices if the ZQ calibration timings for each LPDDR2 device do not overlap. The total capacitive loading on the ZQ pin must be limited.

Power Down

Power-down is entered synchronously when CKE is registered LOW and \overline{CS} is HIGH at the rising edge of clock. CKE must be registered HIGH in the previous clock cycle. A NOP command must be driven in the clock cycle following the power-down command. CKE must not go LOW while MRR, MRW, READ, or WRITE operations are in progress. CKE can go LOW while any other operations such as row activation, PRECHARGE, auto precharge, or REFRESH are in progress, but the power-down IDD specification will not be applied until such operations are complete. Power-down entry and exit are shown in below timing diagram.

If power-down occurs when all banks are idle, this mode is referred to as precharge power-down; if power-down occurs when there is a row active in any bank, this mode is referred to as active power-down.

Entering power-down deactivates the input and output buffers, excluding CK, \overline{CK} , and CKE. In power-down mode, CKE must be held LOW; all other input signals are "Don't Care." CKE LOW must be maintained until tCKE is satisfied. VREFCA must be maintained at a valid level during power-down.

VDDQ can be turned off during power-down. If VDDQ is turned off, VREFDQ must also be turned off. Prior to exiting power-down, both VDDQ and VREFDQ must be within their respective minimum/maximum operating ranges.

No refresh operations are performed in power-down mode. The maximum duration in power-down mode is only limited by the refresh requirements outlined in section "REFRESH Command".

The power-down state is excited when CKE is registered HIGH. The controller must drive \overline{CS} HIGH in conjunction with CKE HIGH when exiting the power-down state. CKE HIGH must be maintained until tCKE is satisfied. A valid, executable command can be applied with power-down exit latency tXP after CKE goes HIGH.

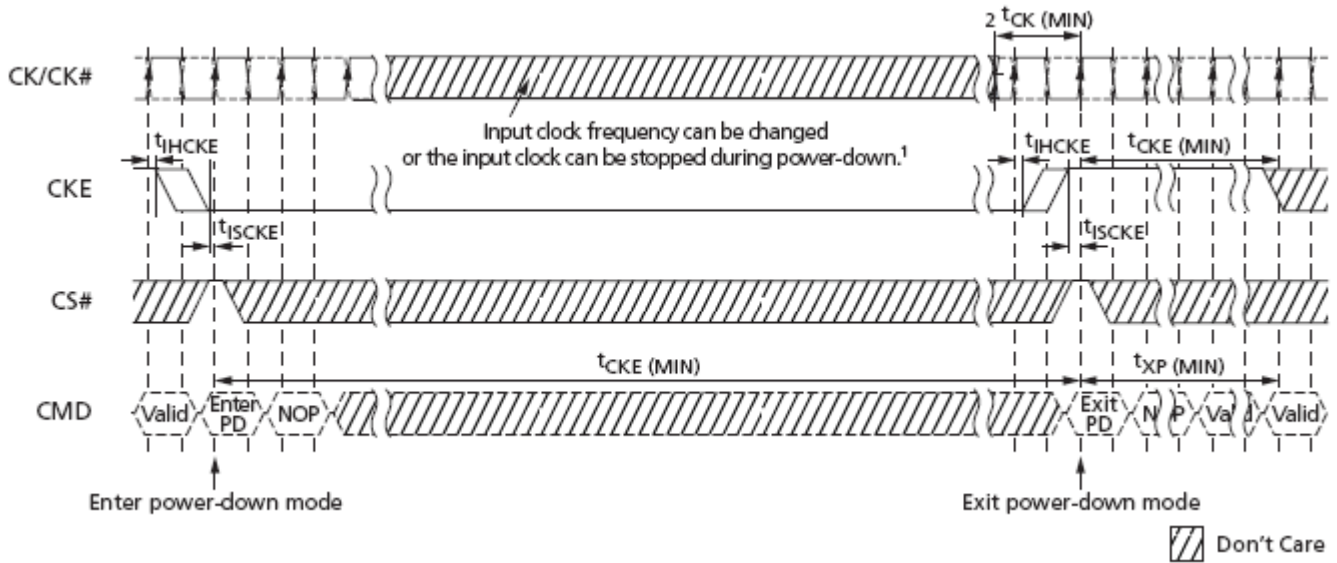

Basic Power-Down entry and exit timing

Notes: Input clock frequency can be changed or the input clock stopped during power-down, provided that the clock frequency is between the minimum and maximum specified frequencies for the speed grade in use, and that prior to power-down exit, a minimum of 2 stable clocks complete.

Power Down (Continued)

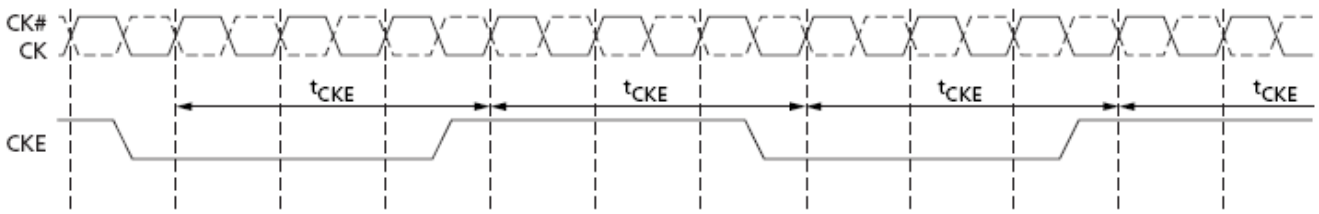

CKE intensive environment

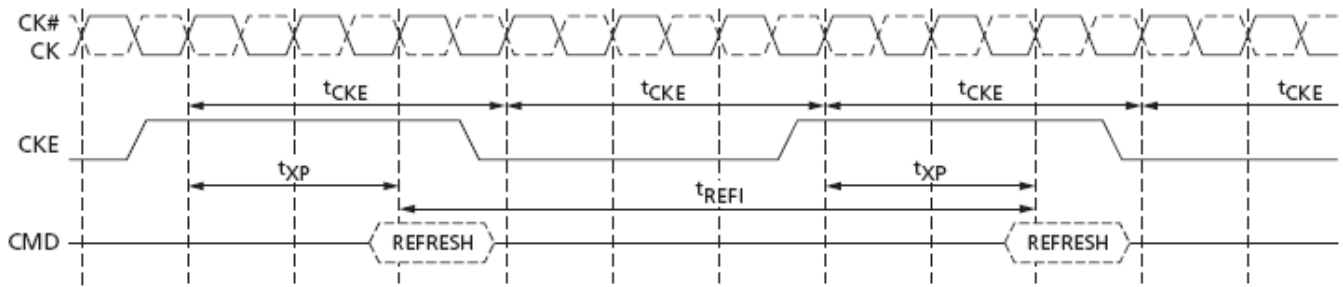

REF to REF timing in CKE intensive environment

Notes:

1. The pattern shown above can repeat over a long period of time. With this pattern, LPDDR2 SDRAM guarantees all AC and DC timing & voltage specifications with temperature and voltage drift ensured.

Power Down (Continued)

BL = 4

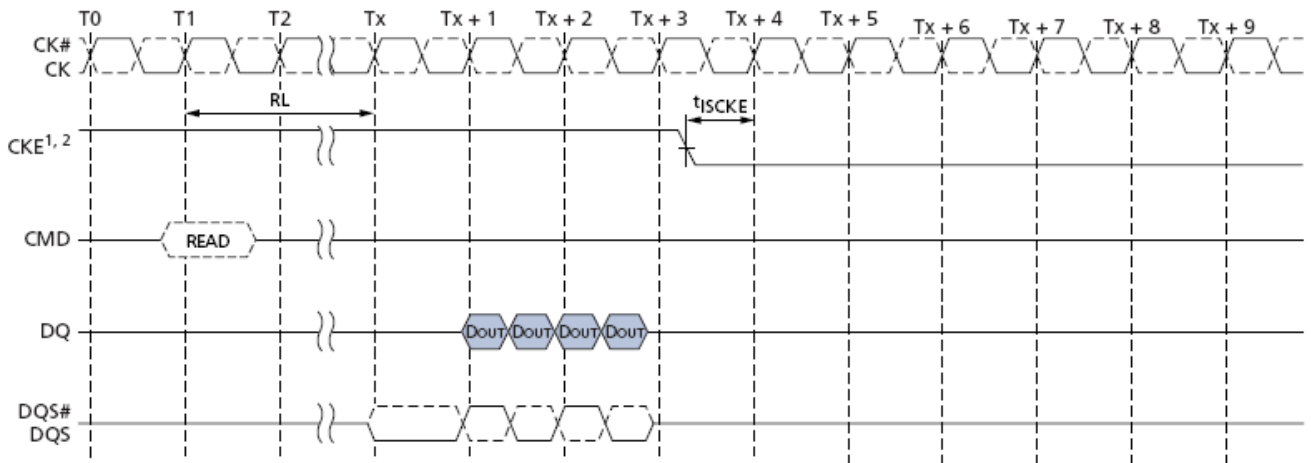

BL = 8

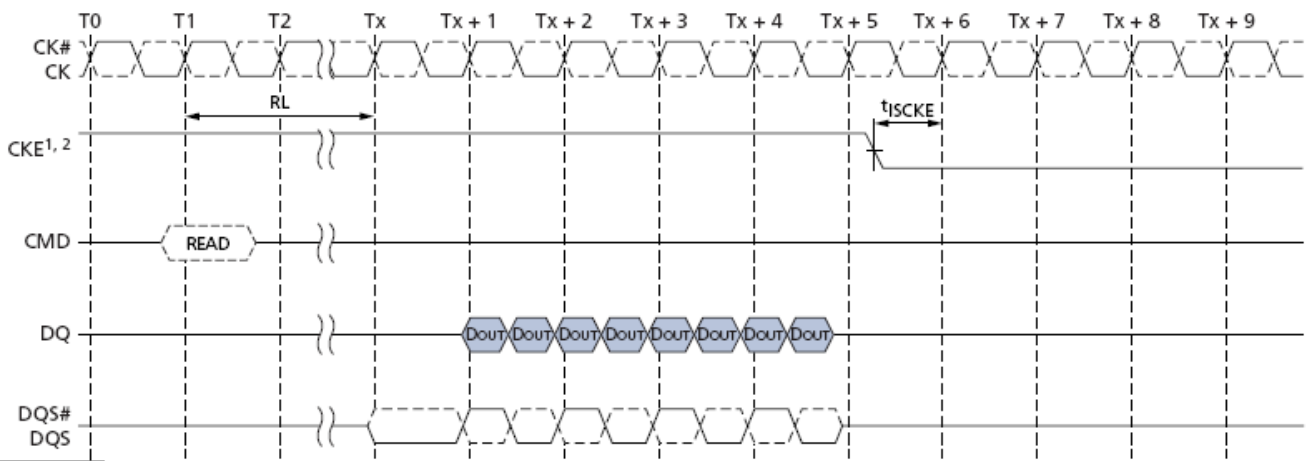

Read to Power-Down entry

Notes:

1. CKE must be held HIGH until the end of the burst operation
2. CKE may be registered LOW $RL + RU(\text{}^t\text{DQSCK}(\text{MAX})/\text{}^t\text{CK}) + BL/2 + 1$ clock cycles after the clock on which the Read command is registered.

Power Down (Continued)

BL = 4

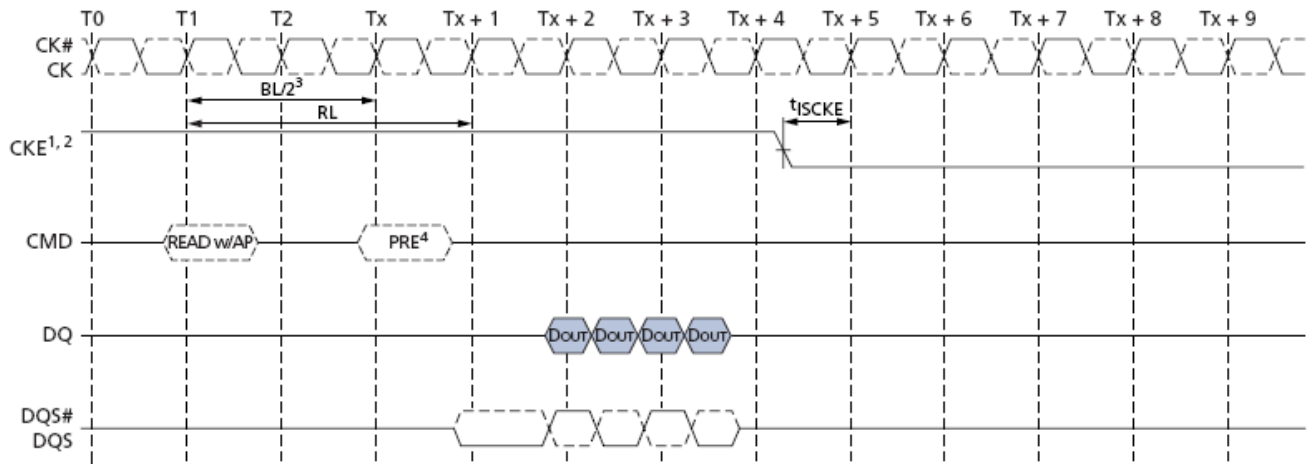

BL = 8

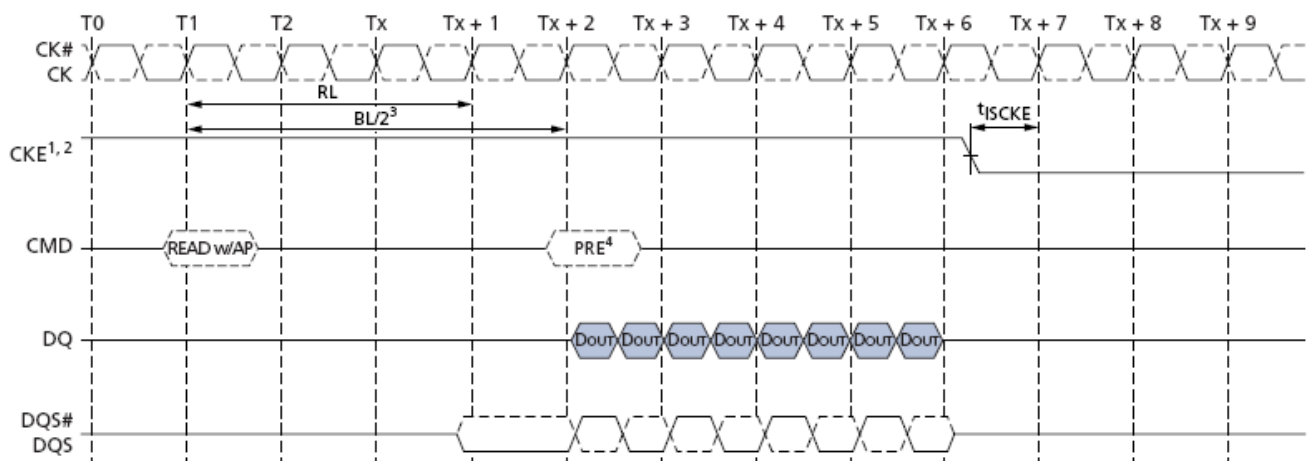

Read with Auto-precharge to Power-Down entry

Notes:

1. CKE must be held HIGH until the end of the burst operation.
2. CKE can be registered LOW at $RL + RU(tDQSK/tCK) + BL/2 + 1$ clock cycles after the clock on which the READ command is registered.
3. BL/2 with $tRTP = 7.5ns$ and $tRAS (MIN)$ is satisfied.
4. Start internal PRECHARGE.

Power Down (Continued)

BL = 4

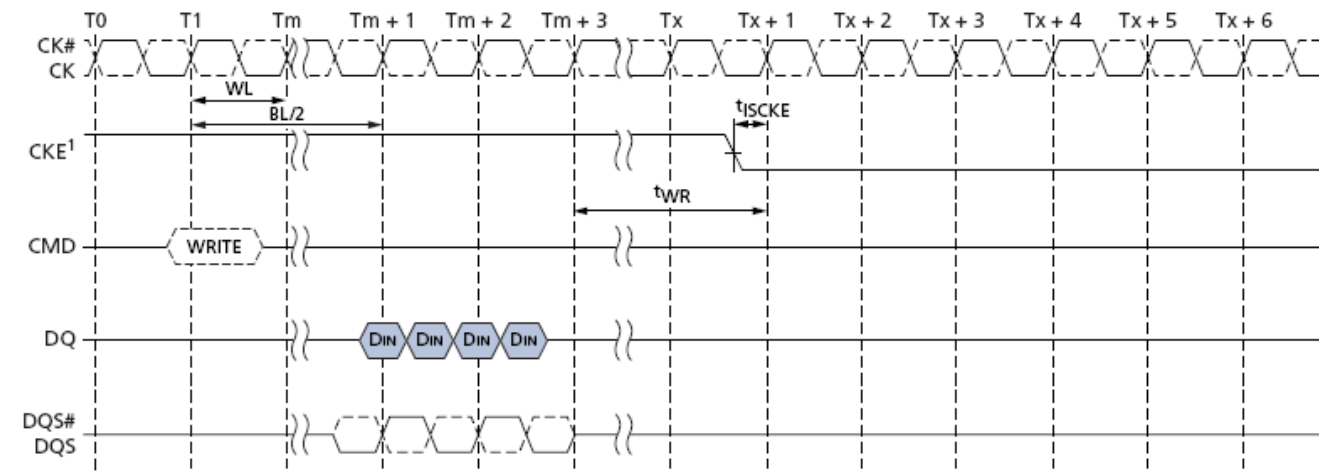

BL = 8

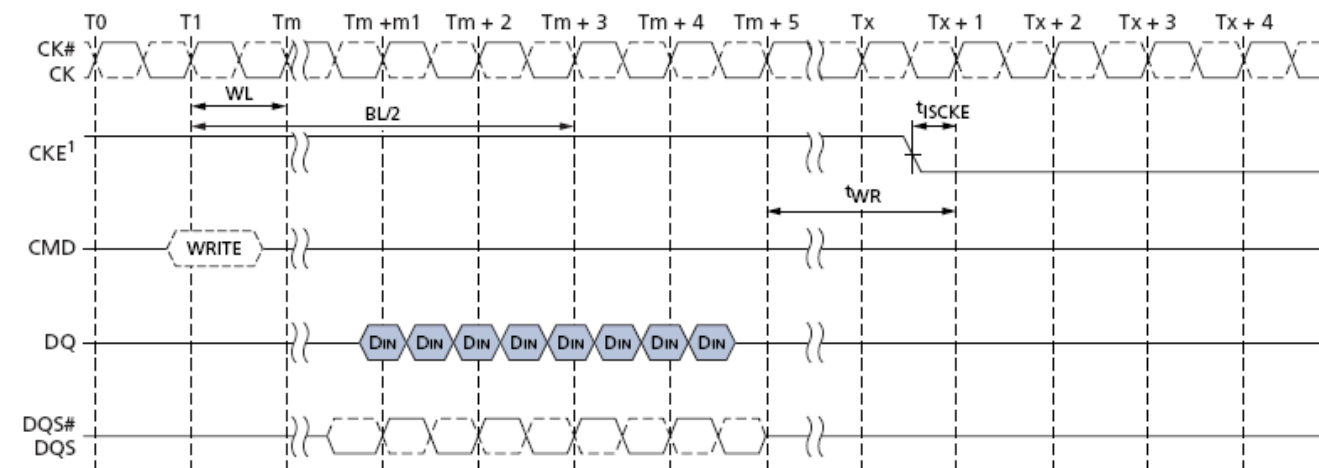

Write to Power-Down entry

Notes:

1. CKE can be registered LOW at $WL + 1 + BL/2 + RU(tWR/tCK)$ clock cycles after the clock on which the WRITE command is registered

Power Down (Continued)

BL = 4

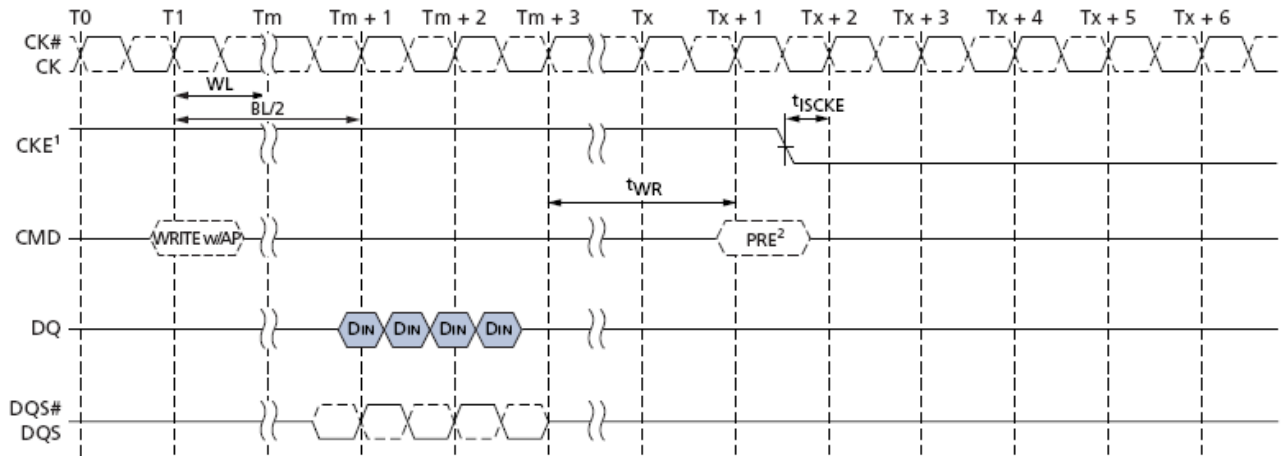

BL = 8

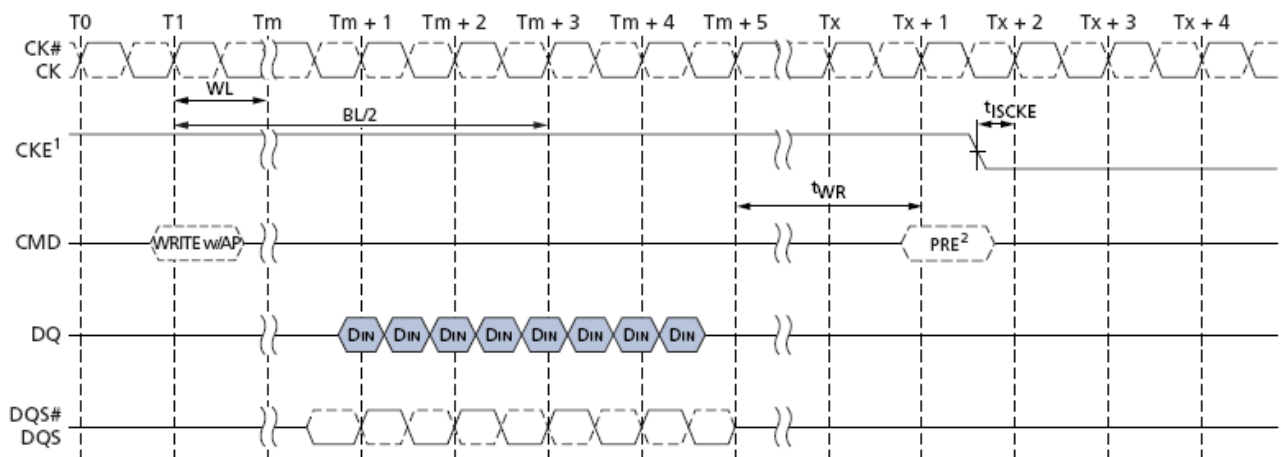

Write with Auto-precharge to Power-Down entry

Notes:

1. CKE may be registered LOW $WL + 1 + BL/2 + RU(t_{WR}/t_{CK}) + 1$ clock cycles after the Write command is registered.
2. Start internal PRECHARGE.

Power Down (Continued)

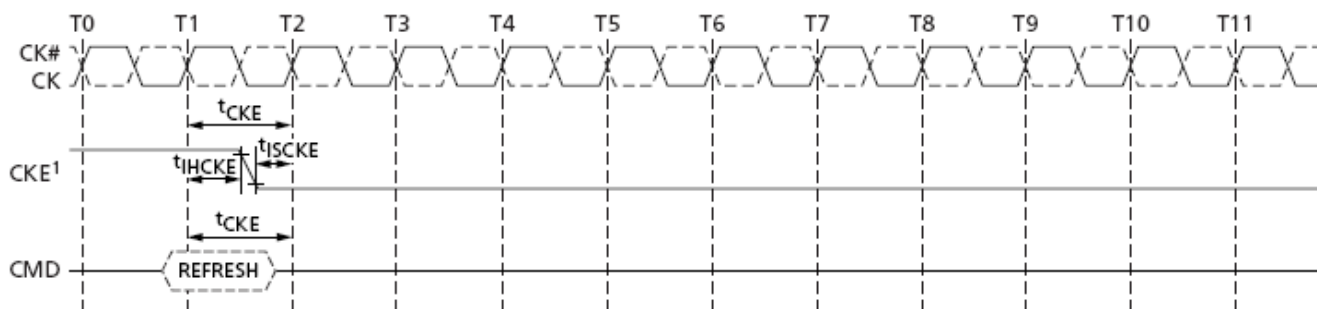

Refresh command to Power-Down entry

Notes:

1. CKE may go LOW t_{IHCKE} after the clock on which the Refresh command is registered.

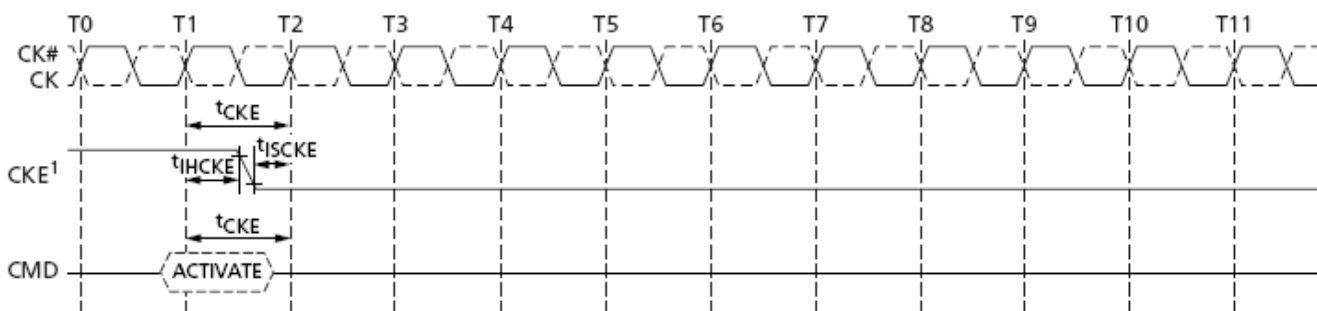

Activate command to Power-Down entry

Notes:

1. CKE may go LOW t_{IHCKE} after the clock on which the Activate command is registered.

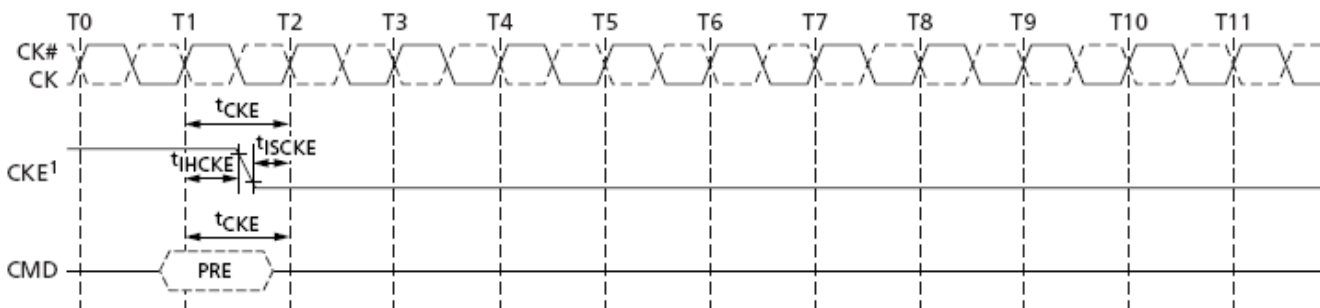

Precharge command to Power-Down entry

Notes:

1. CKE may go LOW t_{IHCKE} after the clock on which the Precharge command is registered.

Power Down (Continued)

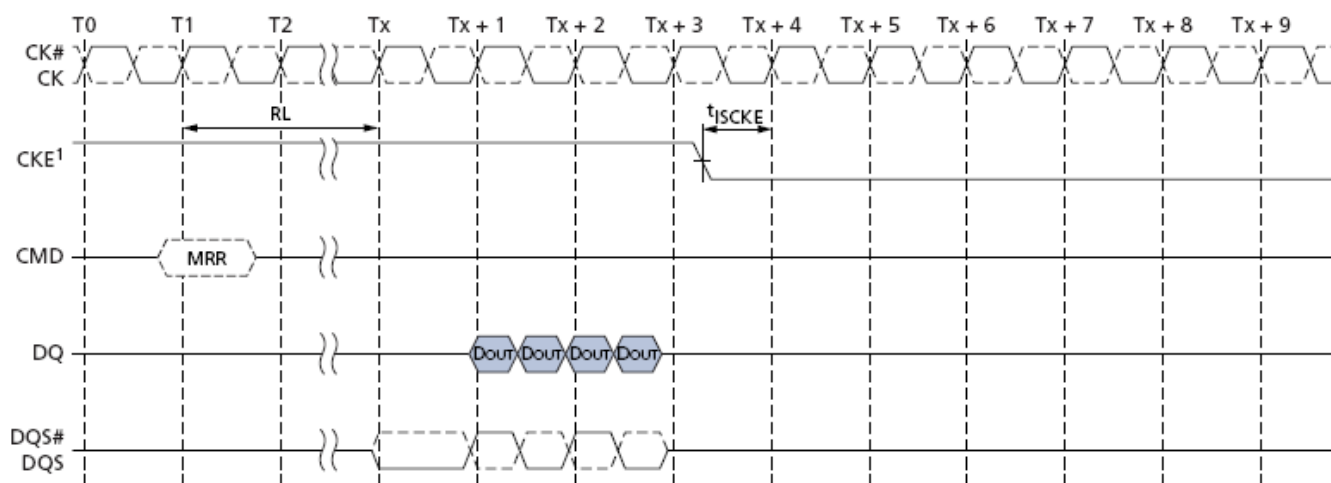

Mode Register Read to Power-Down entry

Notes:

1. CKE may be registered LOW $RL + RU(\overset{t}{DQ}SCK/\overset{t}{CK}) + BL/2 + 1$ clock cycles after the clock on which the Mode Register Read command is registered.

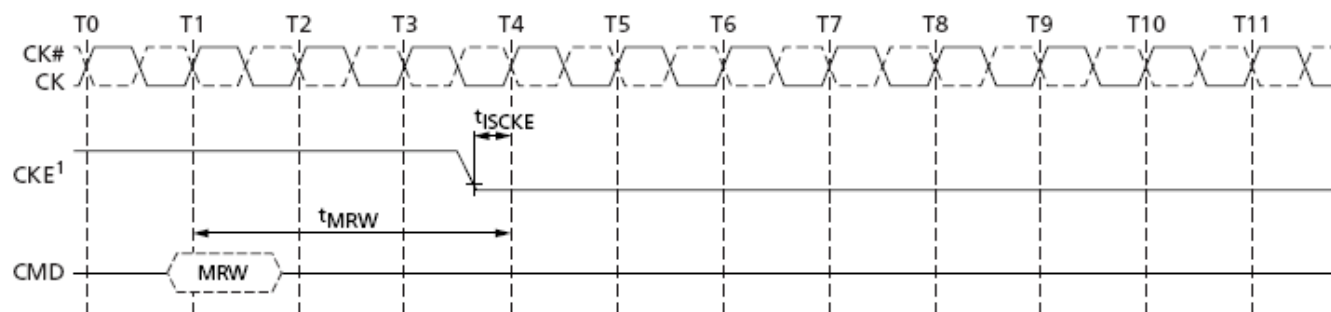

Mode Register Write to Power-Down entry

Notes:

1. CKE may be registered LOW $tMRW$ after the clock on which the Mode Register Write command is registered.

Deep Power Down (DPD)

Deep Power-Down is entered when CKE is registered LOW with CS_n LOW, CA0 HIGH, CA1 HIGH, and CA2 LOW at the rising edge of clock. A NOP command must be driven in the clock cycle following the power-down command. CKE is not allowed to go LOW while mode register, read, or write operations are in progress. All banks must be in idle state with no activity on the data bus prior to entering the Deep Power Down mode. During Deep Power-Down, CKE must be held LOW.

In Deep Power-Down mode, all input buffers except CKE, all output buffers, and the power supply to internal circuitry may be disabled within the SDRAM. All power supplies must be within specified limits prior to exiting Deep Power-Down. VrefDQ and VrefCA may be at any level within minimum and maximum levels. However prior to exiting Deep Power-Down, Vref must be within specified limits.

The contents of the SDRAM may be lost upon entry into Deep Power-Down mode.

The Deep Power-Down state is exited when CKE is registered HIGH, while meeting tISCKE with a stable clock input. The SDRAM must be fully re-initialized as described in the Power up initialization Sequence. The SDRAM is ready for normal operation after the initialization sequence.

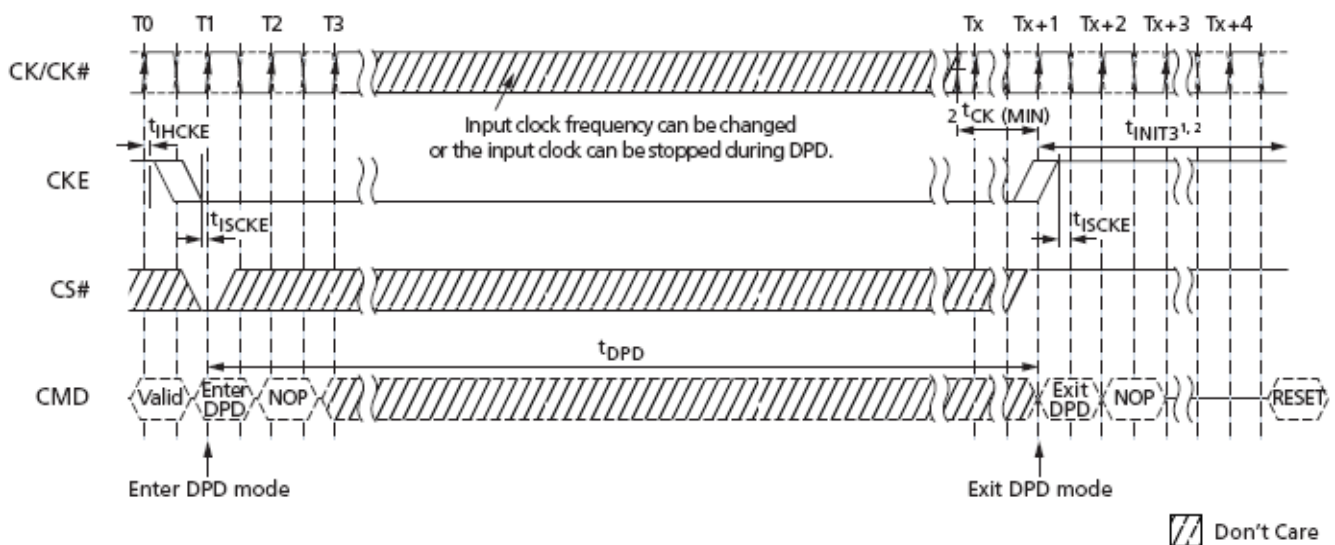

Deep Power-Down entry and exit timing diagram

Notes:

1. Initialization sequence may start at any time after Tx + 1.
2. tINIT3 and Tx + 1 and refer to timings in the initialization sequence.
3. The clock is stable and within specified limits for a minimum of 2 clock cycles prior to deep power down exit and the clock frequency is between the minimum and maximum frequency for the particular speed grade.

Input clock stop and frequency change

LPDDR2 devices support input clock frequency change during CKE LOW under the following conditions:

- $t_{CK(ABS)min}$ is met for each clock cycle
- Refresh requirement apply during clock frequency change
- During clock frequency change, only REFAb or REFpb commands may be executing
- Any ACTIVATE or PRECHARGE commands have completed prior to changing the frequency
- Related timing conditions, t_{RCD} and t_{RP} , have been met prior to changing the frequency
- The initial clock frequency must be maintained for a minimum of 2 clock cycles after CKE goes LOW
- The clock satisfies $t_{CH(ABS)}$ and $t_{CL(ABS)}$ for a minimum of two clock cycles prior to CKE going HIGH.

After the input clock frequency is changed and CKE is held HIGH, additional MRW commands may be required to set the WR, RL, etc. These settings may need to be adjusted to meet minimum timing requirements at the target clock frequency.

LPDDR2 devices support clock stop during CKE LOW under the following conditions:

- CK is held LOW and \overline{CK} is held HIGH during clock stop
- Refresh requirements are met
- Only REFAb or REFpb commands can be in process
- Any ACTIVATE or PRECHARGE commands have completed prior to changing the frequency
- Related timing conditions, t_{RCD} and t_{RP} , have been met prior to changing the frequency
- The initial clock frequency must be maintained for a minimum of 2 clock cycles after CKE goes LOW
- The clock satisfies $t_{CH(ABS)}$ and $t_{CL(ABS)}$ for a minimum of two clock cycles prior to CKE going HIGH.

LPDDR2 devices support input clock frequency change during CKE HIGH under the following conditions:

- $t_{CK(ABS)min}$ is met for each clock cycle
- Refresh requirement apply during clock frequency change
- Any Activate, Read, Write, Precharge, Mode Register Write or Mode Register Read commands must have executed to completion including any associated data bursts prior to changing the frequency
- The related timing conditions (t_{RCD} , t_{WR} , t_{WRA} , t_{RP} , t_{MRW} , t_{MRR} etc) have been met prior to changing the frequency
- CS_n shall be held HIGH during clock frequency change
- During clock frequency change, only REFAb or REFpb commands may be executing
- The LPDDR2 device is ready for normal operation after the clock satisfies $t_{CH(ABS)}$ and $t_{CL(ABS)}$ for a minimum of $2t_{CK}+t_{XP}$.

After the input clock frequency is changed and CKE is held HIGH, additional MRW commands may be required to set the WR, RL, etc. These settings may need to be adjusted to meet minimum timing requirements at the target clock frequency.

Input clock stop and frequency change (Continued)

LPDDR2 devices support clock stop during CKE HIGH under the following conditions:

- CK is held LOW and $\overline{\text{CK}}$ is held HIGH during clock stop
- CS_n shall be held HIGH during clock stop
- Refresh requirements are met
- Only REFAb or REFpb commands can be in process
- Any Activate, Read, Write, Precharge, Mode Register Write or Mode Register Read commands must have executed to completion including any associated data bursts prior to stopping the clock
- The related timing conditions (tRCD, tWR, tWRA, tRP, tMRW, tMRR etc) have been met prior to stopping the clock
- The LPDDR2 device is ready for normal operation after the clock is restarted and satisfies tCH(abs) and tCL(abs) for a minimum of 2tCK+tXP.

No Operation Command

The purpose of the No Operation command (NOP) is to prevent the LPDDR2 device from registering any unwanted command between operations. Only when the CKE level is constant for clock cycle N-1 and clock cycle N, a NOP command may be issued at clock cycle N. A NOP command has two possible encodings:

1. CS_n HIGH at the clock rising edge N.
2. CS_n LOW and CA0, CA1, CA2 HIGH at the clock rising edge N.

The No Operation command will not terminate a previous operation that is still executing, such as a burst read or write cycle.

Revision Log

Rev	Date	Modification
0.1	11/2012	Preliminary Release
0.2	12/2012	Updated Speed 800 IDD Current
0.3	01/2013	Revised Ordering Information
0.4	01/2013	Revised Package Dimensions
1.0	03/2013	Official Release