

December 1993

DESCRIPTION

The SSI 73M223 modem device receives and transmits serial and binary data over existing telephone networks using Frequency Shift Keying (FSK). It provides the filtering, modulation, and demodulation to implement a serial, asynchronous data communication channel. The SSI 73M223 employs the CCITT V.23 signaling frequencies of 1302 and 2097 Hz, operating at 1200 baud, and is intended for half duplex operation over a two-line system.

The SSI 73M223 provides a cost-effective alternative to existing modem solutions. It is ideally suited for R.F. data links, credit verification systems, point-of-sale terminals, and remote process control.

CMOS technology ensures small size, low-power consumption and enhanced reliability.

FEATURES

- Low cost FSK Modem
- 1200 baud operation
- CMOS switched capacitor technology
- Built-in self-test feature
- On-chip filtering, and Modulation/Demodulation
- Uses CCITT V.23 frequencies
- On chip crystal oscillator
- Low power/High reliability
- 16-pin plastic packages

BLOCK DIAGRAM

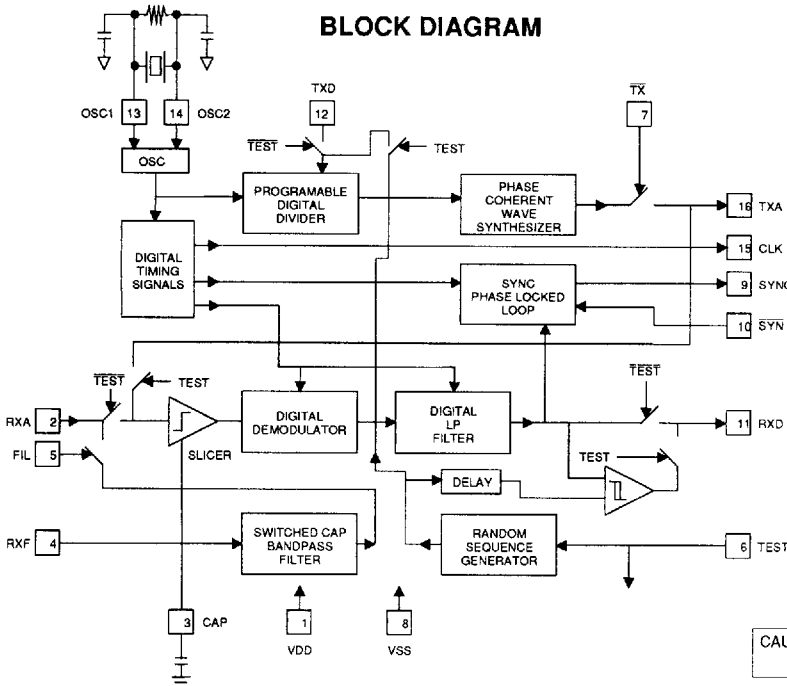

PIN DIAGRAM

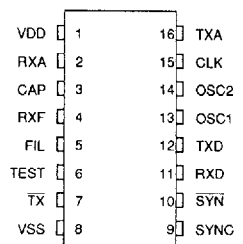

CAUTION: Use handling procedures necessary for a static sensitive component.

SSI 73M223

1200 Baud FSK Modem

FUNCTIONAL DESCRIPTION

The SSI 73M223 has four main functional sections: timing, transmit, receive, and test. Each section of the chip will be individually described below.

TIMING

The timing section contains the oscillator (OSC) and random logic which generates digital timing signals used throughout the chip. The time base can be derived from 3.18 MHz crystal or an external digital input. The digital timing logic divides the oscillator frequency to give a 1200 Hz output than can be used for system timing. The signaling frequencies are 1302 Hz for logic "1" and 2097 Hz for logic "0." The modem will operate with clock inputs from 330 kHz to 3.3 MHz. However, the signaling frequencies and the system timing will be directly proportional to the difference in clock frequency.

TRANSMITTER

The SSI 73M223 transmitter consists of a programmable divider that drives a coherent phase frequency synthesizer. The programmable divider is digitally controlled via the Data Input pin (TXD). The output of the divider clocks a 16 segment phase coherent frequency synthesizer. A sine wave is constructed by eight weighted capacitors which are the inputs to a high pass filter. The synthesized signal is output directly to the transmit pin TXA. The transmit signal can be disabled by using the digital control pin TX.

RECEIVER

The SSI 73M223's receiver is comprised of three sections: the input bandpass filter, the synchronization loop, and the demodulator.

The input bandpass filter is a four pole Butterworth filter, implemented using switched capacitor technology. This filter reduces wideband noise which significantly improves data error rates. The SSI 73M223 can be configured with the bandpass filter in series with the receiver by setting FIL = 1 and inserting the received signal at RXF. The bandpass filter can be deleted from the system by setting FIL = 0 and inputting the received signal through RXA.

The demodulator is used to detect a received mark or space.

The synchronization for sampling the digital output at RXD is derived from a digital phase locked loop. The phase locked loop is clocked at 16 times the bit rate with a maximum lock period of 8 clocks to lock on the data output signal. The output is nominally 1200 Hz, but is resynchronized to the center of the data bit on each data transition.

SELF TEST MODE

The SSI 73M223 features an autotest mode which provides easy field test capability of the chip's functionality. The modem is placed in the test mode by taking the test pin high. In the test mode the Data Input pin is disconnected and the programmable divider is driven by a pseudo random PN sequence generator and the transmitter's output is connected to the receiver's input. The input data to the programmable divider is delayed by the system delay time and compared to the digital output on sync transitions. If the detected data matches the delayed input data from the PN sequence counter, the SSI 73M223 is properly functioning as indicated by RXD low. A high on the RXD pin indicates a functional problem on the SSI 73M223.

SSI 73M223

1200 Baud FSK Modem

PIN DESCRIPTION

PIN NO.	PIN NAME	DESCRIPTION
1	VDD	Positive Supply Voltage. Bypasses to Vss with 0.1 μ F capacitor.
2	RXA	Receive Analog Input. Analog input from the telephone network.
3	CAP	Capacitor. Connect a 0.1 μ F capacitor between Pin 3 and ground (VSS).
4	RXF	Filtered Receive Analog Input
5	FIL	Analog Input Control. A logical 1 selects the filtered input. A logical 0 selects the non-filtered input.
6	TEST	Self-Test Mode Control. Normal operation when a logical 0. A logical 1 places the device into the self-test mode. A low appears at RXD, to indicate a properly functioning device.
7	$\overline{\text{TX}}$	Transmitter Control. A logical 0 selects transmit mode. A logical 1 selects a stand-by condition forcing TXA to VDD/2 VDC.
8	VSS	Ground
9	SYNC	Synchronous Clock Output. Digital output synchronized with the 1200 bit/s received data and used to sample the received eye pattern.
10	$\overline{\text{SYN}}$	Sync Disable. A logical 1 input disables the phase locked signal from the received data and locks it to the 1200 Hz reference. Logic 0 enables Rec PLL.
11	RXD	Receiver Digital Output
12	TXD	Transmitter Digital Input
13	OSC1	Crystal Input (3.1872 MHz) or External Clock Input
14	OSC2	Crystal Return
15	CLK	1200 Hz Squarewave Output. Can drive up to 10 CMOS loads.
16	TXA	Transmitter Analog Output

4

ELECTRICAL SPECIFICATIONS

Recommended conditions apply unless otherwise specified.

ABSOLUTE MAXIMUM RATINGS

Operation outside these rating limits may cause permanent damage to this device.

PARAMETER	RATING
Power Supply Voltage (VDD-VSS)	14 V
Analog Input Voltage at RXA	- 0.3 to VDD V
Analog Input Voltage at RXF	- 3 to VDD V
Digital Input Voltage	VSS - 0.3 to VDD + 0.3 V
Storage Temperature Range	- 65 to + 150 °C
Operating Temperature Range	- 25 to + 70 °C
Lead Temperature (10 secs soldering)	260 °C

SSI 73M223

1200 Baud FSK Modem

ELECTRICAL CHARACTERISTICS

Unless otherwise specified, $4.5 < VDD < 13$ VDC, $VSS = 0$ VDC, $-25^{\circ} C < T_A$

POWER SUPPLY

PARAMETER	TEST CONDITIONS	MIN	NOM	MAX	UNIT
VDD Voltage Supply Range		4.5		13	V
Supply Current	VDD = 5V 25° C		2.0		mA
	VDD = 12V 25° C		5.0		mA
Digital Inputs					
Input Low Voltage VIL		VSS - 0.3		VSS + 1.5	V
Input High Voltage VIH		VDD - 1.5		VDD + 0.3	V
Input Low Current IIL		-1			μA
Input High Current IIH				1	μA
Digital Outputs					
Output Low Voltage VOL	IOL < 1μA			0.05	V
Output High Voltage VOH	IOL < -1μA VDD = 5V	4.95			V
Output Low Current IOL	VOL = 0.4V VDD = 5V	0.5			mA
Output High Current IOH	VOH = 4.5V VDD = 5V	-0.2			mA
Analog Input Level @ RXA	Centered at VDD/2 + 0.5V	0.2		VDD/4	Vpp
Analog Input Level @ RXF	*DC Level between VDD & VSS	0.2		VDD/2	VDC
Error Rate	S/N = 8dB Input @ RXF			5×10^{-3}	
Analog Output Level @ TXA	RL ≥ 10K TX = 0		VDD/4		Vpp
	TX = 1		VDD/2		VDC
Output Frequency @ TXA	XTAL = 3.1872MHz TXD=1		1302		Hz
	TXD=0		2097		Hz
Output Harmonics	2nd to 14th Harmonics		-60	-50	dB
	15th Harmonic			-20	dB
Input Filter (RFX)	*Input = 200 m Vpp to VDD/2 Vpp				
Lower 3dB Corner			760		Hz
Upper 3dB Corner			2625		Hz

* Note: The SSI 73M223 RXF input is AC coupled internally but the DC value of the input must be between the two supplies VDD & VSS.

SSI 73M223 1200 Baud FSK Modem

APPLICATION INFORMATION

The SSI 73M223 modem chip allows low cost communications in a private network, utilizing twisted pair telephone wires. This chip is the prime choice of those designers who require an efficient, high performance modem solution for dedicated private networks, HDX dial-up and other specialized applications. Such applications include credit verification systems, point-of-sale terminals, remote process control, private data links and acoustic modem designs. No microprocessors or external adjustments are necessary with this device.

Utilizing a crystal input of 3.1872 MHz, the SSI 73M223 is a 1200 Baud, FSK modem. The signaling frequencies generated are 1302Hz for a logic "1" and 2097Hz for a logic "0." Crystals with frequencies varying between 330 kHz to 3.3 MHz or higher can be used. The baud rate and signaling frequencies vary linearly with variation in crystal frequency.

A typical implementation on the SSI 73M223 is shown in the figure below. An SSI 73M1550 UART receives data to be transmitted from a microprocessor bus. The UART sends the data in a serial format to the SSI 73M223 modem after inserting the necessary start and stop bits. The modem transmits this data to the far end via the TXA pin. Full-duplex operation can be implemented by utilizing separate transmit and receive circuits. A USART can be used instead of a UART if synchronous operation is desired. With synchronous operation, a USART uses the modem's SYNC signal for timing to sample the received data, and the modem's CLK signal to send data clock to be transmitted.

4

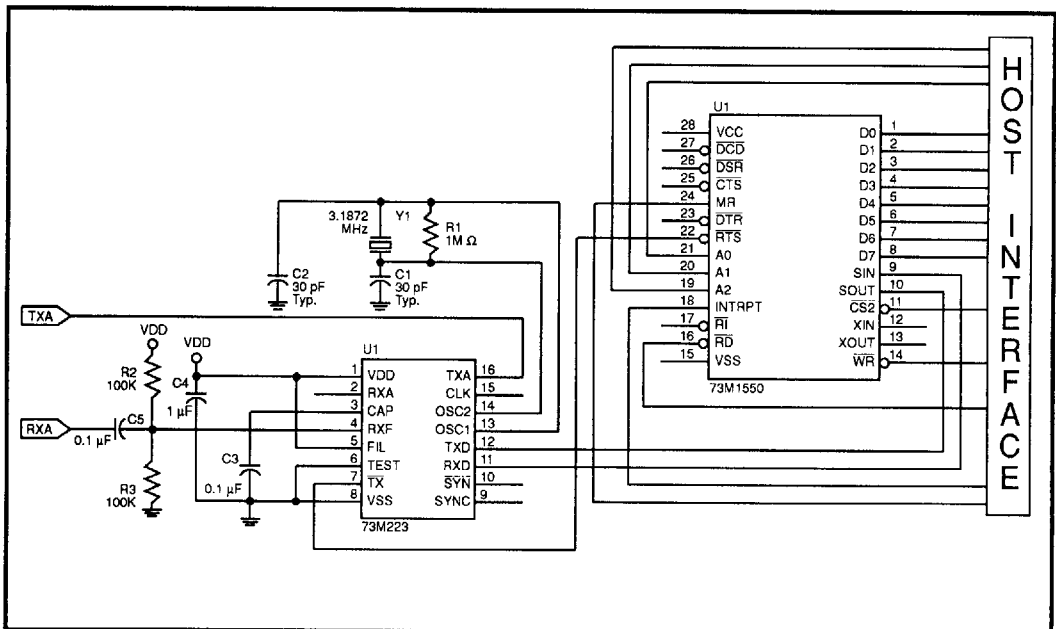

SSI 73M223 TYPICAL APPLICATION

SSI 73M223

1200 Baud FSK Modem

PACKAGE PIN DESIGNATIONS

(Top View)

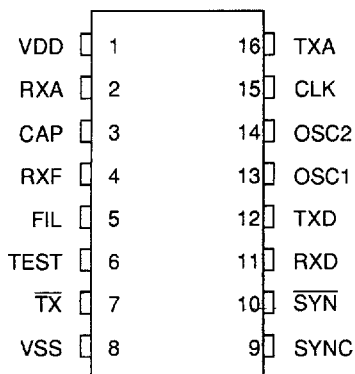

**16-Pin DIP and
16-Lead SOL**

CAUTION: Use handling procedures necessary for a static sensitive component.

ORDERING INFORMATION

PART DESCRIPTION	ORDER NO.	PKG. MARK
SSI 73M223 16-Pin Plastic DIP	73M223 - CP	SSI 73M223 - CP
SSI 73M223 16-Lead SOL	73M223 - CL	SSI 73M223 - CL

No responsibility is assumed by Silicon Systems for use of this product nor for any infringements of patents and trademarks or other rights of third parties resulting from its use. No license is granted under any patents, patent rights or trademarks of Silicon Systems. Silicon Systems reserves the right to make changes in specifications at any time without notice. Accordingly, the reader is cautioned to verify that the data sheet is current before placing orders.

Silicon Systems, Inc., 14351 Myford Road, Tustin, CA 92680-7022, (714) 573-6000, FAX: (714) 573-6914