

N8100A-0142	N Jack Crimp For RG142, RG400; 9GHz VSWR 1.2	50Ω
-------------	---	------------

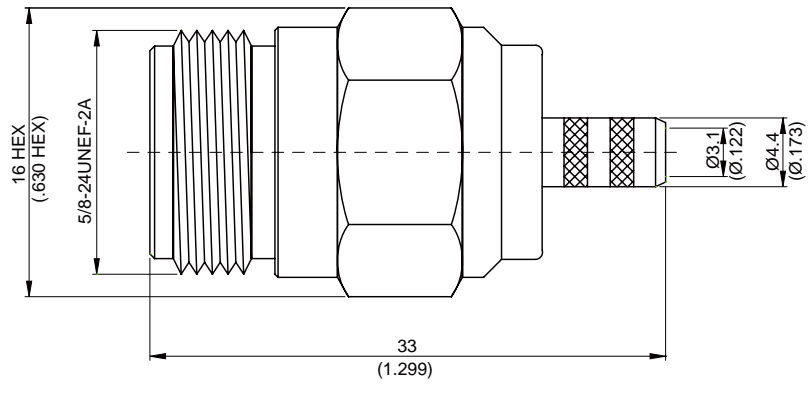

Parts	Material	Plating (Micro-inch)
Ferrule	Brass	Tin-Zinc-Copper-Alloy 100 Over Copper 50
Contact Pin	Phosphor Bronze	Gold 4 Over Nickel-Phosphorus Alloy 80 Over Copper 20
Barrel	Brass	Tin-Zinc-Copper-Alloy 100 Over Copper 50
Ring	Brass	Tin-Zinc-Copper-Alloy 100 Over Copper 50
Insulator	Teflon	
Body	Brass	Tin-Zinc-Copper-Alloy 100 Over Copper 50

Weight: 30.78 g
 Suitable Cables: RG55, RG142, RG400

This part number complies with RoHS.
Notice: JYEBAC reserves the right to make modifications deemed appropriate.

N	N8100A-0142																		
<div style="border: 1px solid black; padding: 2px; margin-bottom: 5px;">Interface</div> MIL-STD-348B																			
<div style="border: 1px solid black; padding: 2px; margin-bottom: 5px;">Electrical Data</div> <table style="width: 100%; border-collapse: collapse;"> <tr> <td style="width: 60%;">Impedance</td> <td>50Ω</td> </tr> <tr> <td>Frequency range</td> <td>DC to 9GHz</td> </tr> <tr> <td>VSWR</td> <td>≦ 1.2 (DC to 9GHz)</td> </tr> <tr> <td>Insertion loss</td> <td>≦ 0.05 x √f(GHz) dB</td> </tr> <tr> <td>Insulation resistance</td> <td>≧ 5000MΩ</td> </tr> <tr> <td>Contact resistance inner conductor</td> <td>≦ 1.5mΩ</td> </tr> <tr> <td>Contact resistance outer conductor</td> <td>≦ 1mΩ</td> </tr> <tr> <td>Dielectric withstanding voltage (at sea level)</td> <td>2500 V rms</td> </tr> <tr> <td>Working voltage (at sea level)</td> <td>1000 V rms</td> </tr> </table>		Impedance	50Ω	Frequency range	DC to 9GHz	VSWR	≦ 1.2 (DC to 9GHz)	Insertion loss	≦ 0.05 x √f(GHz) dB	Insulation resistance	≧ 5000MΩ	Contact resistance inner conductor	≦ 1.5mΩ	Contact resistance outer conductor	≦ 1mΩ	Dielectric withstanding voltage (at sea level)	2500 V rms	Working voltage (at sea level)	1000 V rms
Impedance	50Ω																		
Frequency range	DC to 9GHz																		
VSWR	≦ 1.2 (DC to 9GHz)																		
Insertion loss	≦ 0.05 x √f(GHz) dB																		
Insulation resistance	≧ 5000MΩ																		
Contact resistance inner conductor	≦ 1.5mΩ																		
Contact resistance outer conductor	≦ 1mΩ																		
Dielectric withstanding voltage (at sea level)	2500 V rms																		
Working voltage (at sea level)	1000 V rms																		
<div style="border: 1px solid black; padding: 2px; margin-bottom: 5px;">Mechanical Data</div> <table style="width: 100%; border-collapse: collapse;"> <tr> <td style="width: 60%;">Recommended coupling nut torque</td> <td>6 to 10 inch lbs</td> </tr> <tr> <td>Coupling proof torque</td> <td>15 inch lbs</td> </tr> <tr> <td>Contact captivation-axial</td> <td>≧ 6.3 lbs</td> </tr> <tr> <td>Durability (mating)</td> <td>≧ 500</td> </tr> </table>		Recommended coupling nut torque	6 to 10 inch lbs	Coupling proof torque	15 inch lbs	Contact captivation-axial	≧ 6.3 lbs	Durability (mating)	≧ 500										
Recommended coupling nut torque	6 to 10 inch lbs																		
Coupling proof torque	15 inch lbs																		
Contact captivation-axial	≧ 6.3 lbs																		
Durability (mating)	≧ 500																		
<div style="border: 1px solid black; padding: 2px; margin-bottom: 5px;">Environmental Data</div> <table style="width: 100%; border-collapse: collapse;"> <tr> <td style="width: 60%;">Temperature range</td> <td>-65°C to +165°C</td> </tr> <tr> <td>Thermal shock</td> <td>MIL-STD-202, Method 107, Condition B</td> </tr> <tr> <td>Moisture resistance</td> <td>MIL-STD-202, Method 106</td> </tr> <tr> <td>Corrosion</td> <td>MIL-STD-202, Method 101, Condition B</td> </tr> <tr> <td>RoHS</td> <td>Compliant</td> </tr> </table>		Temperature range	-65°C to +165°C	Thermal shock	MIL-STD-202, Method 107, Condition B	Moisture resistance	MIL-STD-202, Method 106	Corrosion	MIL-STD-202, Method 101, Condition B	RoHS	Compliant								
Temperature range	-65°C to +165°C																		
Thermal shock	MIL-STD-202, Method 107, Condition B																		
Moisture resistance	MIL-STD-202, Method 106																		
Corrosion	MIL-STD-202, Method 101, Condition B																		
RoHS	Compliant																		
<div style="border: 1px solid black; padding: 2px; margin-bottom: 5px;">Tooling</div> <table style="width: 100%; border-collapse: collapse;"> <tr> <td style="width: 60%;">Crimping tool</td> <td>CRT-1 or CRT-2</td> </tr> <tr> <td>Crimp insert</td> <td>INSERT-B</td> </tr> </table>		Crimping tool	CRT-1 or CRT-2	Crimp insert	INSERT-B														
Crimping tool	CRT-1 or CRT-2																		
Crimp insert	INSERT-B																		

Notice: JYEBAO reserves the right to make modifications deemed appropriate.

JYE BAO CO., LTD.

CABLE ASSEMBLY INSTRUCTION

N8100A-0142	DATE	2021/02/24	REV	-
-------------	------	------------	-----	---



<p>A</p>  <p style="text-align: center;">BODY</p>	<p>B</p>  <p style="text-align: center;">CONTACT PIN</p>	<p>C</p>  <p style="text-align: center;">FERRULE</p>
--	---	---

DIAGRAM	ASSEMBLY INSTRUCTION
---------	----------------------

	<p>Step 1: STRIP AS SHOWN.</p>
--	--------------------------------

	<p>Step 2: SLIDE FERRULE " C " OVER CABLE. Step 3: PUT PIN " B " ON CENTER CONDUCTOR AND SOLDER OR CRIMP IN " Y ". (USE SQUARE 2.4mm/0.094inch SECTION OF INSERT-B IF CRIMPED)</p>
---	--

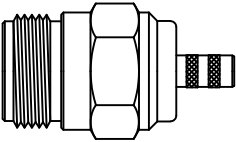
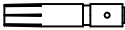
	<p>Step 4: LOOSEN BRAIDING AND SLIDE CONNECTOR " A " IN PLACE.</p>
---	--

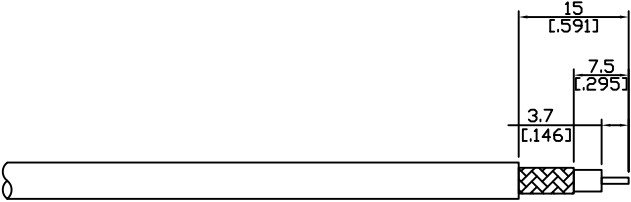
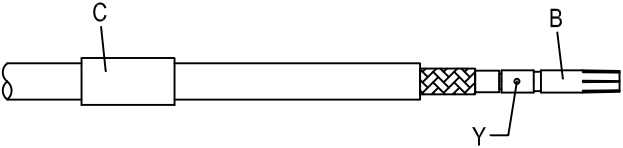
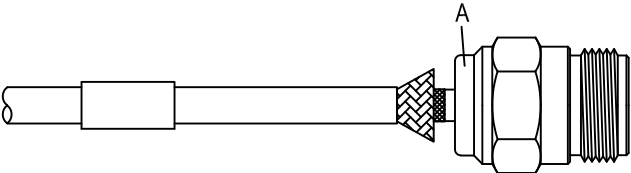
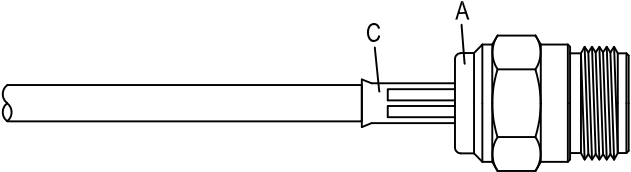
	<p>Step 5: SLIDE FERRULE " C " TOWARDS THE CONNECTOR " A " AND CRIMP. (USE 5.5mm/0.217inch HEX SECTION OF INSERT-B)</p>
---	--

This part number complies with RoHS.

Notice: JYEBAO reserves the right to make modifications deemed appropriate.

APPROVED	CHECKED	DRAWING
----------	---------	---------

Albert

N8100A-0142

