

# DMS Accessories

## 5 Volt, Isolated and Non-Isolated DC/DC Converters for DMS Series Meters

Order on-line at [www.datel.com](http://www.datel.com)

**Isolated:** These miniature, 5V-output dc/dc converters are ideal for applications requiring isolation between the input signal being measured and the panel meter's +5V power source. They can eliminate common mode voltages up to 750V. A popular application requiring isolation is high-side, current-shunt, dc ammeters (see DMS Ap Note 6 for information on dc ammeters). Any 5V-powered, 3½ digit, DMS Series meter whose supply current does not exceed 225mA may be powered from these converters. Low-noise operation can be obtained in most 4½ digit meter applications by simply adding filter components to the converter's output pins.

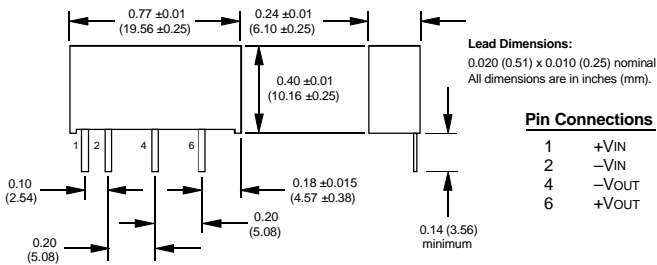

**Non-Isolated:** The LM7805CT (DATEL part number 39-0304000) is a highly reliable, three-terminal IC regulator that provides a non-isolated +5V output from input voltages between +7.5 and +28Vdc. However, when it is used to power DATEL DMS Series panel meters, the allowable operating input voltage applied to the LM7805CT should not exceed the ranges specified in the table below. The LM7805CT can be used with the DMS-EB, DMS-EB2 and DMS-EB-DC/DC application boards; each board is pre-wired to accept the regulator. Refer to each board's data sheet for more information. Please consult DATEL's Application Engineers if you have any questions regarding the use of dc/dc converters with any DMS Series meter.

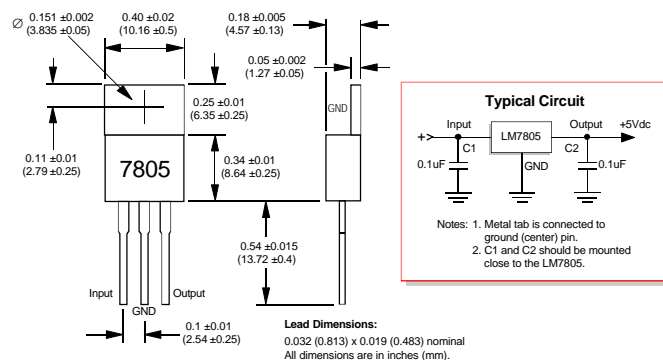

### Electrical Specifications (Isolated)

DATEL Part No./Marking	Nominal Input Voltage	Input Current			
		Min. Load	Max. Load		
39-0276600/HPR100	+5Vdc	20mA	216mA		
39-0276715/HPR106	+12Vdc	10mA	90mA		
39-0276610/HPR118	+24Vdc	8mA	44mA		
Input Range	Conditions	Min.	Typ.	Max.	Units
39-0276600		+4.5	+5	+5.5	Vdc
39-0276715		+10.8	+12	+13.2	Vdc
39-0276610		+21.6	+24	+26.4	Vdc
Output					
Rated Current		—	150	—	mA
Voltage Setpoint	Rated load, nom. $V_{IN}$	+4.75	+5.0	+5.5	Vdc
Ripple and Noise	BW=dc to 10MHz	—	45	—	mVp-p
	BW=10Hz to 2MHz	—	30	—	mVrms
Isolation					
Rated Voltage		750	—	—	Vdc
Test Voltage	60Hz, 10 seconds	750	—	—	Vpk
Leakage Current	Viso=240Vac, 60Hz	—	2	8.5	µArms
Temperature					
Operating		-25	—	+85	°C
Storage		-40	—	+110	°C

### Absolute Maximum Ratings

Internal Power Dissipation	450mW
Output Short-Circuit Duration	1 second
Lead Temperature (soldering, 10 seconds max.)	+300°C

### Electrical Specifications (Non-Isolated)

Input Range	Min.	Typ.	Max.	Units
Input Voltage	+7.5	—	+28	Vdc
Output @+25°C				
Output Voltage	+4.75	+5.0	+5.5	Vdc
Output Current	—	—	1000	mA
Maximum Input ①				
DMS-20PC-X-XS	+7.5	—	+12.6	Vdc
DMS-20PC-X-XL	+7.5	—	+24.0	Vdc
DMS-30PC-X-XS	+7.5	—	+12.6	Vdc
DMS-30PC-X-XL	+7.5	—	+18.0	Vdc
DMS-30LCD-X-5(B)	+7.5	—	+18.0	Vdc
Temperature				
Operating	-25	—	+85	°C
Storage	-40	—	+110	°C

① When used with the following DMS Series panel meters up to +60°C max.