



Built-in EEPROM and Unique ID-ROM I²C-Bus INTERFACE REAL TIME CLOCK MODULE



RX-8731 LC

- Built in frequency adjusted 32.768 kHz crystal unit.
- Interface Type : I²C-Bus interface (400 kHz)
- Operating voltage range : 1.7 V to 5.5 V
- Wide Timekeeper voltage range : 1.3 V to 5.5 V
- Low backup current : 0.35 μA / 3 V (Typ.)
- 32.768 kHz frequency output function : C-MOS output With Control Pin
- The various functions include full calendar, alarm, timer.

* The I²C-Bus is a trademark of NXP Semiconductors

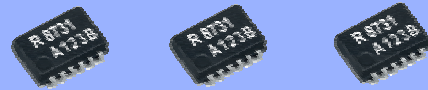

Actual size

Block diagram

Overview

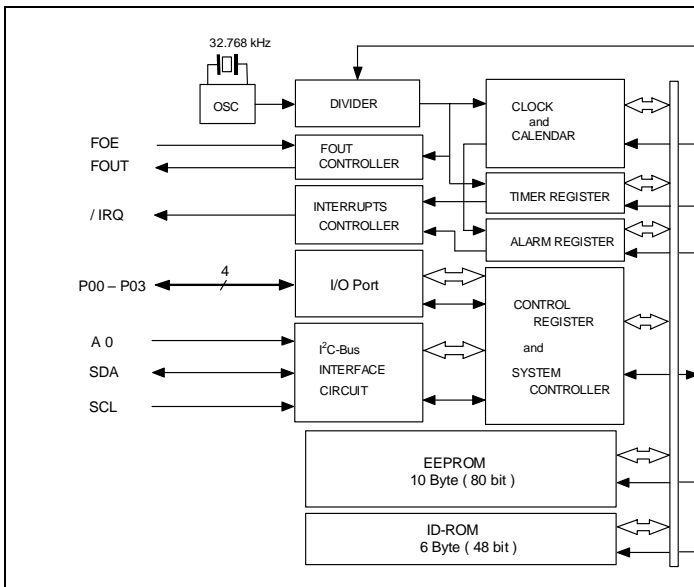

- **Built in EEPROM and ID-ROM**
 - Built in 10 Byte (80 bit) EEPROM
 - Built in 6 Byte (48 bit) ID-ROM
- **Programmable I/O ports**
 - 4 Programmable I/O ports
- **Interface Type**
 - I²C-Bus high-speed bus specifications. (400 kHz)
- **32.768 kHz frequency output function**
 - FOUT pin output (C-MOS output), CL=30 pF
 - FOE pin enables output on/off control.
 - Output frequency is selectable.
< 32.768 kHz, 1024 Hz, 1 Hz >
- **The various interrupt function**
 - Alarm interrupt function
 - Timer interrupt function
 - Update interrupt function

Pin Function

Terminal connection / External dimensions (Unit:mm)

Signal Name	Input / Output	Function
SCL	Input	Serial Clock input pin.
SDA	Bi-directional	Data input and output pin.
A 0	Input	Device address A0 input pin.
FOUT	Output	FOUT pin is 32.768 kHz clock output pin (C-MOS) that output control is possible.
FOE	Input	FOE pin control the frequency output from FOUT pin with FSEL1-bit and FSEL0-bit.
/IRQ	Output	Interrupt output pin. (N-ch open drain)
P00 P01 P02 P03	Bi-directional	Programmable I/O ports.
VDD	—	Connected to a positive power supply.
GND	—	Connected to a ground.

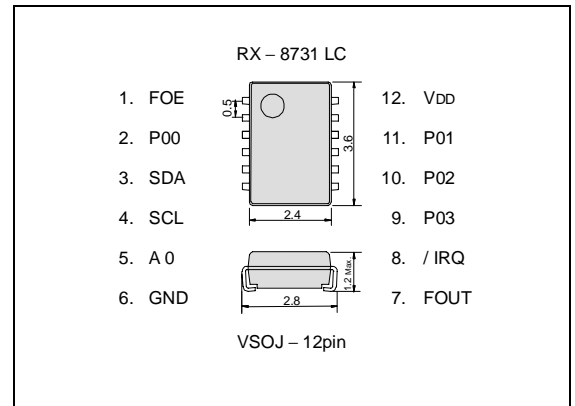

Specifications (characteristics)

* Refer to application manual for details.

Recommended Operating Conditions

Item	Symbol	Condition	Min.	Typ.	Max.	Unit
Power voltage	VDD	—	1.7	3.0	5.5	V
Clock voltage	VCLK	—	1.3	3.0	5.5	V
Operating temperature	TOPR	—	-40	+25	+85	°C

Frequency characteristics

Item	Symbol	Condition	Rating	Unit
Frequency tolerance	$\Delta f / f$	Ta = +25 °C VDD = 3.0 V	5 ± 23 *	× 10 ⁻⁶
Oscillation Start-up time	tSTA	Ta = +25 °C VDD = 1.6 V	1 Max.	s
		Ta = -40 °C to +85 °C VDD = 1.6 V	3 Max.	s

*Equivalent to 1 minute of monthly deviation

Current consumption characteristics

Ta = -40 °C to +70 °C

Item	Symbol	Condition	Min.	Typ.	Max.	Unit
Current Consumption	IBK	fSCL = 0 Hz / IRQ = OFF FOUT : output OFF (Hi - z)	VDD = 5 V	0.45	0.9	μA
			VDD = 3 V	0.35	0.7	
Current Consumption	I32k	fSCL = 0 Hz / IRQ = OFF FOUT : 32.768 kHz output CL = 30 pF	VDD = 5 V	8.0	16.0	μA
			VDD = 3 V	5.0	10.0	