



**HEWLETT
PACKARD**

BAR CODE DECODE ICs

Contact Scanners • HBCR-1800, -1801, -1810, -1811
Multi-Purpose • HBCR-2000, -2001, -2010, -2011

TECHNICAL DATA OCTOBER 1988

Features

- IDEAL FOR HAND SCANNING APPLICATIONS AND MANY AUTOMATED SCANNING APPLICATIONS
- WIDE SELECTION OF INDUSTRY STANDARD BAR CODES SUPPORTED
- AUTOMATIC CODE RECOGNITION
- FULL DUPLEX ASCII INTERFACE
- EXTENSIVE CONFIGURATION CONTROL VIA SOFTWARE COMMANDS
- NMOS OR CMOS
- 40 PIN DIP OR 44 PIN PLCC PACKAGES
- AUDIO AND VISUAL FEEDBACK CONTROL
- SINGLE +5 VOLT SUPPLY

Selection Guide

Feature	IC Series	
	1800	2000
Wand/Slot Reader Input	X	X
Hand Held Laser Input		X
Code 39	X	X
Interleaved 2 of 5	X	X
UPC/EAN	X	X
Codabar		X
Code 128		X
Serial Port	X	X
Xon/Xoff Pacing	X	X
RTS/CTS Handshake		X
1200, 2400, 9600 Baud	X	X
300 Baud	X	
4800 Baud		X
Parallel Port	X	

Description

Hewlett-Packard's Bar Code Decoder ICs offer flexible bar code decoding capability that is designed to give OEMs the ability to address a large number of industry segments and applications. Flexibility is made possible through sophisticated firmware which allows the ICs to accept data from a wide variety of scanners and to automatically recognize and decode the most popular bar code symbologies. User implementation of the decoder ICs is easy since it requires only a few supporting chips and components and provides a standard I/O interface.

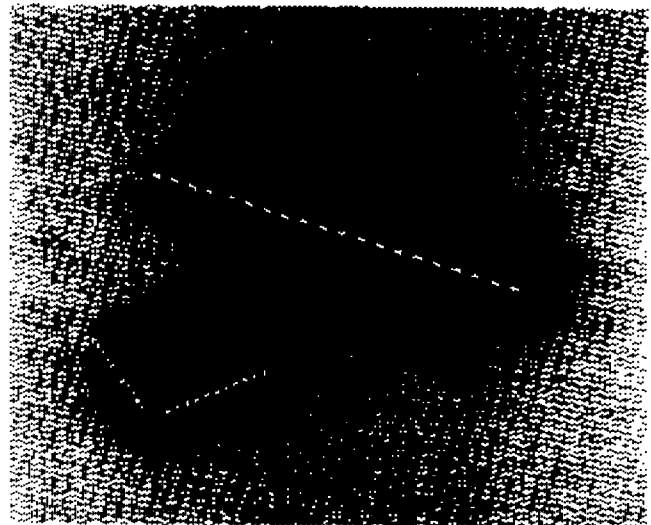

Manufacturers of data collection terminals, point of sale terminals, keyboards, weighing scales, and other data collection and material handling equipment are finding a growing demand for bar code reading capability in their products. The Hewlett-Packard bar code decoder ICs make it easy to add this capability without the need to invest in the development of bar code decoding software.

The bar code decoder ICs are compatible with most hand held scanners. Both the HBCR-2000 series and the HBCR-1800 series are compatible with fixed beam non-contact scanners, digital wands, and digital slot readers. The HBCR-2000 series is also compatible with Symbol Technologies moving beam laser scanners.

The HBCR-2000 decoder ICs are excellent decoding solutions for a number of the stationary scanning applications found in automated systems. The scan rates for moving beam applications should be similar to the scan rates for hand held laser scanners (35 to 45 scans per second), and the scan speeds for fixed beam applications should be similar to the scan speeds typical of wands and slot readers. For moving beam applications, it is also necessary for the scanner to utilize the three laser scanner control lines.

The decoder ICs decode the bar code symbologies now in use for most applications in the industrial, retail, government, and medical markets. Both series of ICs support Code 39 (Standard or Extended), Interleaved 2 of 5, and the UPC/EAN/JAN Codes. The HBCR-2000 series will also decode Codabar and Code 128. Whenever more than one symbology is enabled, the bar code being scanned will automatically be recognized and decoded, except for Standard and Extended Code 39 which are mutually exclusive. Bi-directional scanning is allowed for all bar codes except UPC/EAN/JAN with supplemental digits, which must be scanned with the supplemental digits last.

The I/O for the decode ICs is full duplex, 7 bit ASCII. A serial port is available on both the 1800 and the 2000 series ICs. A parallel port is available on the 1800 series. The serial interface can be converted to an RS232C interface or connected directly to another microprocessor for data processing. The parallel interface can be connected to a tri-level bus through a 74LS245 or equivalent. Feedback to the operator is accomplished by signals for an LED and a beeper. In addition, there are programmable functions covering items such as code selection and beeper tone.

The HBCR-1800 and HBCR-2000 ICs are available in NMOS and CMOS, in either a 40 pin DIP package or a 44 pin PLCC package. All ICs require a dedicated external data memory, 2K or 8K x 8 bit static RAM (only 1K is needed) and address latch chip (a 74LS373 or equivalent). The crystal frequency for the HBCR-2000 series is 11.059 MHz, and the frequency for the HBCR-1800 series is 12.000 MHz.

Performance Features

BAR CODES SUPPORTED

Both series of decoder ICs are capable of reading popular bar code symbologies: Code 39 (Standard or Extended), Interleaved 2 of 5, and UPC/EAN/JAN. The HBCR-2000 series will decode two additional codes, Codabar (NW7 Code), and Code 128.

Code 39 is an alphanumeric code, and Extended Code 39 encodes the full 128 character ASCII character set by pairing Code 39 characters. Both can be read bi-directionally with message lengths of up to 32 characters. An optional checksum character can be used with these codes, and the ICs can be configured to verify this character prior to data transmission. Note that enabling Extended Code 39 will disable Code 39 since they are mutually exclusive.

Interleaved 2 of 5 code, a compact numeric only bar code, can also be read bi-directionally with message lengths from 4 to 32 characters. To enhance data accuracy, optional checksum character verification and/or message length checking can be enabled.

The following versions of the UPC, EAN, and JAN bar codes can be read bi-directionally: UPC-A, UPC-E, EAN-8, EAN-13, JAN-8, and JAN-13. All versions can be enabled simultaneously or decoding can be restricted to only the UPC codes.

UPC, EAN, and JAN codes printed with complementary two digit or five digit supplemental encodings can be read in two different ways. If the codes are enabled without the supplemental encodings, then only the main part of symbols printed with supplemental encodings will be read. If the reading of supplemental encodings is enabled, then only symbols with these supplements will be read. Whenever supplemental encodings are enabled, the bar code symbols must be read in the direction which results in the supplements being scanned last.

Codabar, a numeric only bar code with special characters, can be read bi-directionally for message lengths up to 32 characters. The start and stop characters are normally transmitted, but can be suppressed by a software command.

Code 128, a full ASCII bar code, can also be scanned bi-directionally with message lengths of up to 32 characters.

SCANNER INPUT

The decoder ICs are designed to accept data from hand held digital scanners or slot readers with the following logic state: black = high, white = low. The 2000 series also accepts data from hand held laser scanners with the opposite logic states: black = low, white = high. The scanner type pin (SCT) on the 2000 series must be driven prior to power up or hard reset to identify the type of scanner attached to it.

In the 2000 series ICs, the automatic laser shutoff feature delay time is adjustable by software commands. Applications which require extreme accuracy may need the redundancy check feature. If either motor failure sensing or calculation of the ratio of laser on time to off time is needed for an application, it must be supported with external circuitry.

Scanner input can be disabled by software command. This allows an application program to control when an operator can enter data, preventing inadvertent data entry. It also allows the program to verify each scan before enabling subsequent scans. The 2000 ICs also offer a single read mode which allows the application program to stop bar code data entry until a "Next Read" command is received, allowing the host computer to process data transmissions before enabling subsequent reads.

DATA COMMUNICATIONS

The serial port supports a wide range of baud rates, parities, stop bits, and terminator characters, as described in Table 1. Software control of data transmission is accomplished with an X_{ON}/X_{OFF} (DC1/DC3) handshake. The 2000 series also has an RTS/CTS hardware handshake.

The parallel port data has odd parity. The default terminator character is a C_R , but it can be changed by software commands. An X_{ON}/X_{OFF} (DC1/DC3) software handshake is available to control data transmission.

FEEDBACK FEATURES

Both audio and visual feedback are possible with the decoder ICs. In both cases, the outputs from the ICs must be buffered before driving the actual feedback mechanism. An LED or beeper connected to the decoder ICs can be controlled directly by the IC, with signals generated by successful decodes; or can be controlled by the host system. In addition, the tone of the beeper can be varied by software commands to be one of 16 different frequencies, or can be silenced.

POWER REQUIREMENTS

The decoder IC operates from a +5 volt DC power supply. The maximum current draw of the NMOS IC is 175 mA, and of the CMOS IC is 19 mA. The maximum power supply ripple voltage should be less than 100 mV, peak-to-peak.

CONFIGURATION CONTROL

Configuration of the decoder IC is determined by hardware connections and/or through software commands. Hardware selection is limited to key operating parameters. A greater range of configuration control is available via software commands. A summary of the decoder IC features and configuration control is presented in Tables 2 and 3.

Handling Precautions



The decoder ICs are extremely sensitive to electrostatic discharge (ESD). It is important that proper anti-static procedures be observed when handling the ICs. The package should not be opened except in a static free environment.

Manuals

The manuals for the ICs cover information such as data output formats, I/O interfaces, laser input timing diagrams, escape sequence syntax and functionality, example schematics, external clock timing, LED and beeper driver circuits, scanner positioning and tilt, sample bar code symbols, and Appendices on bar code symbolologies.

Ordering Information

Table 1. Part Numbers

Part Number	Description
HBCR-1800	NMOS, 40 pin DIP, bulk ship, no manual
HBCR-1801	NMOS, 44 pin PLCC, bulk ship, no manual
HBCR-1810	CMOS, 40 pin DIP, bulk ship, no manual
HBCR-1811	CMOS, 44 pin PLCC, bulk ship, no manual
HBCR-2000	NMOS, 40 pin DIP, bulk ship, no manual
HBCR-2001	NMOS, 44 pin PLCC, bulk ship, no manual
HBCR-2010	CMOS, 40 pin DIP, bulk ship, no manual
HBCR-2011	CMOS, 44 pin PLCC, bulk ship, no manual
Option A01	IC individually boxed with manual
HBCR-1997	Series 1800 manual
HBCR-2997	Series 2000 manual

Recommended Operating Conditions

HBCR-1800, -1801, -2000, -2001

Parameter	Symbol	Minimum	Maximum	Units	Notes
Supply Voltage	V_{CC}	4.5	5.5	V	1
Ambient Temperature	T_A	0	+70	°C	
Crystal Frequency	XTAL	3.500	12.000	MHz	2
Element Time Interval (Moving Beam)	ETI_M	22	555	μs	2, 3, 4
Element Time Interval (Fixed Beam)	ETI_F	150	70,000	μs	3, 4
Element Time Interval (Contact Scanner)	ETI_C	150	70,000	μs	3, 4

HBCR-1810, -1811, -2010, -2011

Parameter	Symbol	Minimum	Maximum	Units	Notes
Supply Voltage	V_{CC}	4.0	6.0	V	1
Ambient Temperature	T_A	-40	+85	°C	
Crystal Frequency	XTAL	0 (DC)	12.000	MHz	2
Element Time Interval (Moving Beam)	ETI_M	22	555	μs	2, 3, 4
Element Time Interval (Fixed Beam)	ETI_F	150	70,000	μs	3, 4
Element Time Interval (Contact Scanner)	ETI_C	150	70,000	μs	3, 4

Notes:

- Maximum power supply ripple of 100 mV peak-to-peak.
- The HBCR-1800 series uses a 12.000 MHz crystal. The HBCR-2000 series uses an 11.059 MHz crystal. For different crystal frequencies, multiply the specified baud rate and beeper frequencies by $\frac{XTAL}{11.059 \text{ MHz}}$ or $\frac{XTAL}{12.000 \text{ MHz}}$ and multiply the element time interval ranges by $\frac{11.059 \text{ MHz}}{XTAL}$ or $\frac{12.000 \text{ MHz}}{XTAL}$.
- At the specified crystal frequency.
- Corresponds to a scan rate of 35 to 45 scans per second.

Absolute Maximum Ratings

HBCR-1800, -1801, -2000, -2001

Parameter	Symbol	Minimum	Maximum	Units	Notes
Storage Temperature	T_S	-55	+150	°C	
Pin Voltage	V_{IN}	-0.5	+7.0	V	5
Power Dissipation	P_D		1.5	W	

HBCR-1810, -1811, -2010, -2011

Parameter	Symbol	Minimum	Maximum	Units	Notes
Storage Temperature	T_S	-55	+150	°C	
Supply Voltage	V_{CC}	-0.5	+7.0	V	6
Pin Voltage	V_{IN}	-0.5	$V_{CC} + 0.5$	V	5, 6

Notes:

- Voltage on any pin with respect to ground.
- $T_A = 25^\circ\text{C}$

DC Characteristics

HBCR-1800, -1801, -2000, -2001 ($T_A = 0^\circ\text{C}$ to $+70^\circ\text{C}$, $V_{CC} = 4.5\text{ V}$ to 5.5 V , $V_{SS} = 0\text{ V}$)

Symbol	Parameter	1800, 2000 Pins	1801, 2001 Pins	Minimum	Maximum	Units	Test Conditions
V_{IL}	Input Low Voltage	all	all	-0.5	0.8	V	
V_{IH}	Input High Voltage	except 9, 18	except 10, 20	2.0	$V_{CC} + 0.5$	V	
V_{IH1}	Input High Voltage	9, 18	—	2.5	$V_{CC} + 0.5$	V	Pin 19 = 0 V
		—	10, 20				Pin 21 = 0 V
V_{OL}	Output Low Voltage	1-8, 10-17, 21-28	2-9, 11, 13-19, 24-31		0.45	V	$I_{OL} = 1.6\text{ mA}$
V_{OL1}	Output Low Voltage	30, 32-39	33, 36-43		0.45	V	$I_{OL} = 3.2\text{ mA}$
V_{OH}	Output High Voltage	1-8, 10-17, 21-28	2-9, 11, 13-19, 24-31	2.4		V	$I_{OH} = -80\text{ }\mu\text{A}$
V_{OH}	Output High Voltage	30, 32-39	33, 36-43	2.4		V	$I_{OH} = -400\text{ }\mu\text{A}$
I_{IL}	Input Low Current	1-8, 10-17, 21-28	2-9, 11, 13-19, 24-31		-800	μA	$V_{IN} = 0.45\text{ V}$
I_{IL2}	Input Low Current	18	20		-3.2	mA	$V_{IN} = 0.45\text{ V}$
I_{LI}	Input Leakage Current	32-39	36-43		± 10	μA	$0.45 \leq V_{IN} \leq V_{CC}$
I_{IH1}	Input High Current	9	10		500	μA	$V_{IN} < V_{CC} - 1.5\text{ V}$
I_{CC}	Power Supply Current	—	—		175	mA	All outputs disconnected

HBCR-1810, -1811, -2010, -2011 ($T_A = 40^\circ\text{C}$ to $+85^\circ\text{C}$, $V_{CC} = 4.5\text{ V}$ to 5.5 V , $V_{SS} = 0\text{ V}$)

Symbol	Parameter	1800, 2000 Pins	1801, 2001 Pins	Minimum	Maximum	Units	Test Conditions
V_{IL}	Input Low Voltage	all	all	-0.5	$0.2 V_{CC} - 0.1$	V	
V_{IH}	Input High Voltage	except 9, 18	except 10, 20	$0.2 V_{CC} + 0.9$	$V_{CC} + 0.5$	V	
V_{IH1}	Input High Voltage	9, 18	10, 20	$0.7 V_{CC}$	$V_{CC} + 0.5$	V	
V_{OL}	Output Low Voltage	1-8, 10-17, 21-28	2-9, 11, 13-19, 24-31		0.45	V	$I_{OL} = 1.6\text{ mA}$
V_{OL1}	Output Low Voltage	30, 32-39	33, 36-43		0.45	V	$I_{OL} = 3.2\text{ mA}$
V_{OH}	Output High Voltage	1-8, 10-17, 21-28	2-9, 11, 13-19, 24-31	2.4		V	$I_{OH} = -60\text{ }\mu\text{A}$
				$0.75 V_{CC}$		V	$I_{OH} = -30\text{ }\mu\text{A}$
				$0.9 V_{CC}$		V	$I_{OH} = -10\text{ }\mu\text{A}$
V_{OH}	Output High Voltage	30, 32-39	33, 36-43	2.4		V	$I_{OH} = -400\text{ }\mu\text{A}$
				$0.75 V_{CC}$		V	$I_{OH} = -150\text{ }\mu\text{A}$
				$0.9 V_{CC}$		V	$I_{OH} = -40\text{ }\mu\text{A}$
I_{IL}	Input Low Current	1-8, 10-17, 21-28	2-9, 11, 13-19, 24-31	-10	-200	μA	$V_{IN} = 0.45\text{ V}$
I_{IL2}	Input Low Current	18	20		-3.2	mA	$V_{IN} = 0.45\text{ V}$
I_{LI}	Input Leakage Current	32-39	36-43		± 10	μA	$0.45 \leq V_{IN} \leq V_{CC}$
R_{RST}	Pulldown Resistor	9	10	20	125	$\text{K}\Omega$	
I_{CC}	Power Supply Current	—	—		18	mA	All outputs disconnected
I_{CC}	Idle Mode Power Supply Current	—	—		9	mA	Note 7.

Note:

7. Applies only to HBCR-2010 and 2011 in Wand Mode with no scanning or I/O operation in progress.

Table 2. Summary of Features and Configuration Control—HBCR-1800 Series

Feature	Function or Value	Hardware/ Software Control ⁽⁸⁾	Default Setting ⁽⁹⁾	Mode ⁽¹⁰⁾	Notes
Mode of Operation	Parallel or Serial Mode	Hardwire	Parallel	N/A	
Baud Rate	300, 1200, 2400, 9600	Hardwire	300 Baud	Serial	
Parity	0s, 1s, Odd, Even	Hardwire	0s	Serial	11
Stop Bits	1 or 2	Hardwire	2	Serial	
Terminator Character	CR, CR LF, HT, None	Hardwire	CR	Serial	
	User defined (10 characters max.)	Software	CR	Both	12
Header Character	User defined (10 characters max.)	Software	No header character	Both	
Data Output Character	X _{ON} /X _{OFF} (DC1/DC3)	Software	No pacing	Both	
Industrial Code Select	Code 39 Interleaved 2 of 5	Software	Code 39 Interleaved 2 of 5 code UPC/EAN/JAN codes	Both	
	Extended Code 39	Both			
UPC/EAN/JAN Code Select	UPC/EAN/JAN together; or UPC only	Software	Supplements not enabled Zeros included	Both	
	Enable 2 or 5 Digit supplements	Software			
	Suppress zeros UPC-E	Software			
Checksum Verification Enable	Code 39 checksum	Both	No Checksum Verification	Both	
	Interleaved 2 of 5 checksum	Software			
Interleaved 2 of 5 Label Length Check	User defined up to 32 characters or variable length	Software	Variable length	Both	
Scanner Disable	Disables scanner input	Software	Input enabled	Both	
Good Read Beep Select	Enables good read beep in one of 16 tones	Software	Beep signal enabled; tone = 15	Both	
Sound Tone	Command to sound tones Defines one of 16 tones	Software	N/A	Both	
LED Control	Controls LED driver circuit	Software	LED to flash upon good read	Both	
Status Request	Gives status of decoder IC configuration	Software	N/A	Both	
Hard Reset	Resets decoder IC to hardwire configuration and default software settings	Software	N/A	Both	

Notes:

- 8. Software commands are sent by means of escape sequences.
- 9. Default settings are those settings which result when the relevant pins have been tied to +5V and no software commands have been sent to the decoder IC.
- 10. Some functions apply only when the decoder IC is operating in the serial mode. Others apply in both the parallel and serial modes.
- 11. In parallel mode, the parity is always odd.
- 12. In the parallel mode the terminator character is CR unless changed through software commands.

HBCR-1800 Series — Serial Pinout

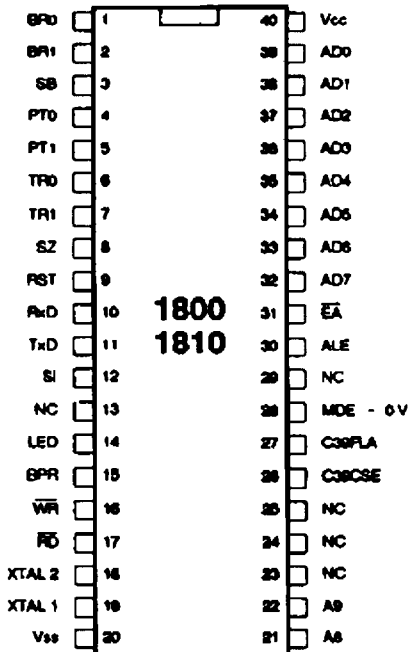

Mnemonic	Description
BR0	Baud Rate Select 0
BR1	Baud Rate Select 1
SB	Stop Bits
PT0	Parity Select 0
PT1	Parity Select 1
TR0	Trailer Select 0
TR1	Trailer Select 1
RxD	Received Data
TxD	Transmitted Data
LED	LED Control
BPR	Beeper Control
RST	Reset
SI	Scanner Input
SZ	Suppress Zeroes, UPC-E
NC	No Connect
EA	Connect to +5V
ALE	Address Latch Enable
MDE	Mode
WR	Memory Write
RD	Memory Read
XTAL 1	Crystal Input 1
XTAL 2	Crystal Input 2
C39FLA	Code 39 Full ASCII Conversion
C39CSE	Code 39 Check Character Enable
AD0-AD7	Address/Data Bits 0-7
A8	Memory Address Line 8
A9	Memory Address Line 9
Vss	Ground
Vcc	+5V Power

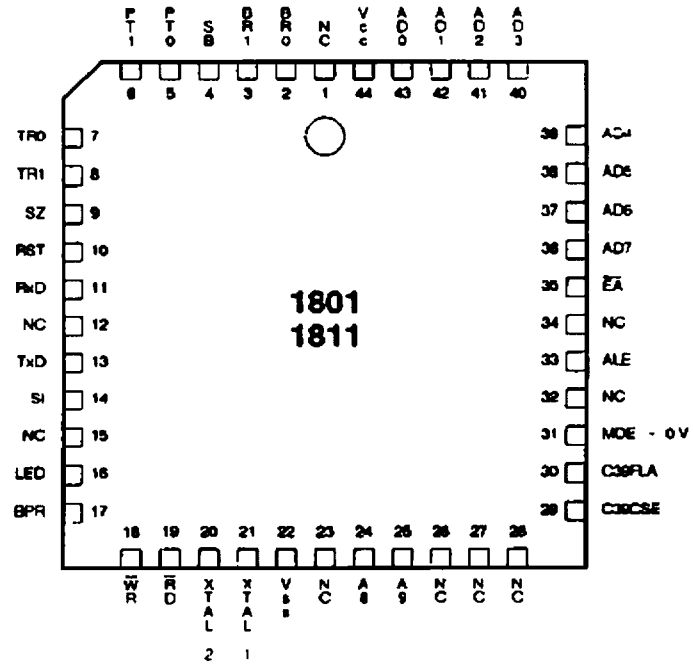

HBCR-1800 Series — Parallel Pinout

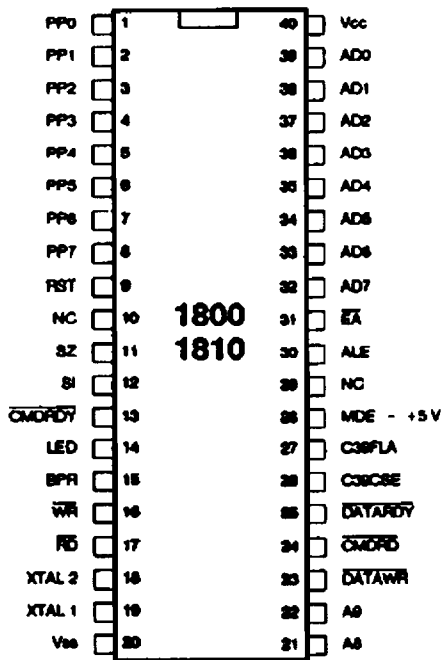

Mnemonic	Description
PP0-PP7	Parallel Port Bits 0-7
$\overline{\text{CMDRDY}}$	Command Ready
$\overline{\text{CMDRD}}$	Command Read
$\overline{\text{DATARDY}}$	Data Ready
$\overline{\text{DATAWR}}$	Data Write
LED	LED Control
BPR	Beeper Control
RST	Reset
SI	Scanner Input
SZ	Suppress Zeroes, UPC-E
NC	No Connect
$\overline{\text{EA}}$	Connect to +5V
ALE	Address Latch Enable
MDE	Mode
$\overline{\text{WR}}$	Memory Write
$\overline{\text{RD}}$	Memory Read
XTAL 1	Crystal Input 1
XTAL 2	Crystal Input 2
C39FLA	Code 39 Full ASCII Conversion
C39CSE	Code 39 Check Character Enable
AD0-AD7	Address/Data Bits 0-7
A8	Memory Address Line 8
A9	Memory Address Line 9
V _{SS}	Ground
V _{CC}	+5V Power

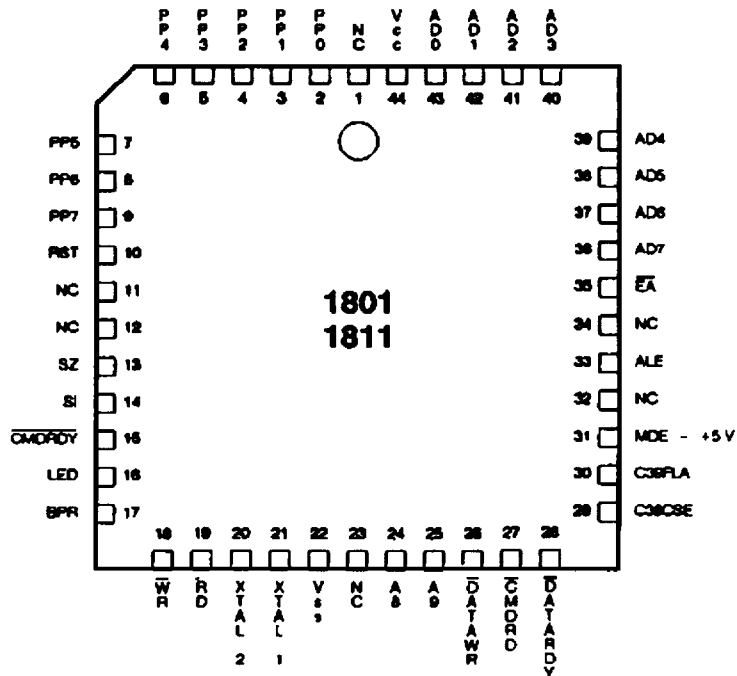

Parallel Mode Handshake Timing — HBCR-1800 Series

Host Commands Received by Decoder IC

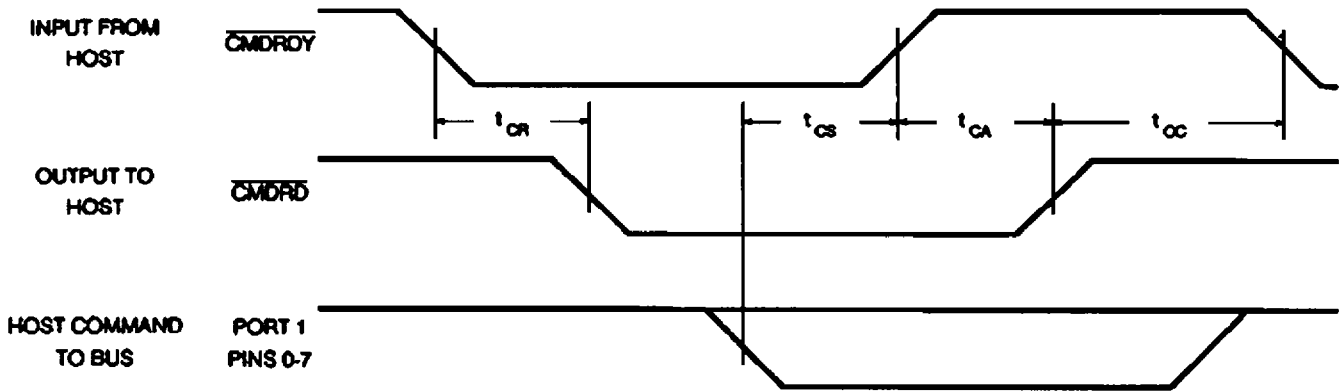

t_{CR} = Falling edge of $\overline{\text{CMDRDY}}$ to falling edge of $\overline{\text{CMDRD}}$. Maximum = 22 μs

t_{CS} = Command setup to rising edge of $\overline{\text{CMDRDY}}$. Minimum = 0 μs

t_{CA} = Rising edge of $\overline{\text{CMDRDY}}$ to rising edge of $\overline{\text{CMDRD}}$. Typical = 6 μs

t_{CC} = Rising edge of $\overline{\text{CMDRD}}$ to falling edge of $\overline{\text{CMDRDY}}$. Minimum = 0 μs

Note:

13. These timing specifications given are based on the assumption that the scanner is not active at the time. Since scanner input to the IC is interrupt driven, the timing might be stretched if the scanner is active during that time. All the timings assume the IC runs at 12 MHz.

Decoder IC Data Sent to Host

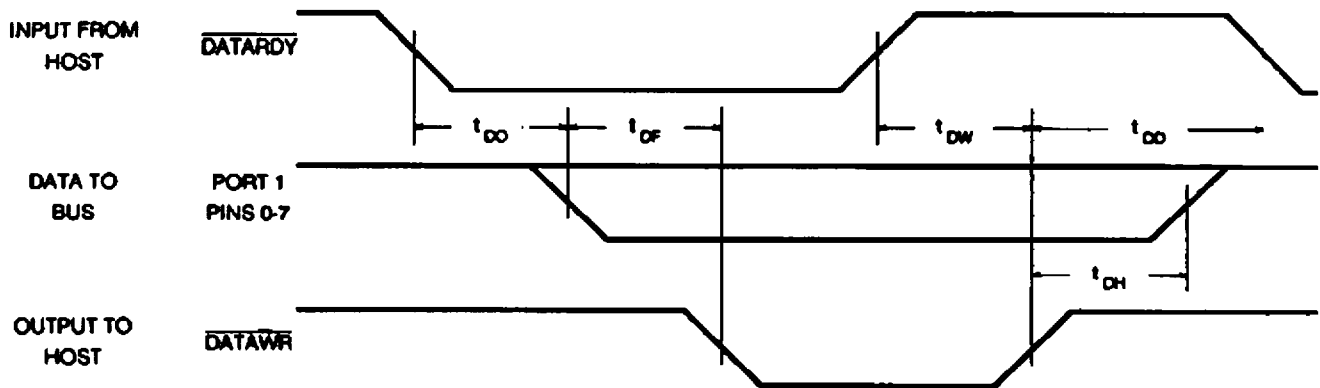

t_{OD} = Falling edge of $\overline{\text{DATARDY}}$ to data output to bus. Maximum = 140 μs

t_{OF} = Data output to bus to falling edge of $\overline{\text{DATAWR}}$. Maximum = 2 μs

t_{OW} = Rising edge of $\overline{\text{DATARDY}}$ to rising edge of $\overline{\text{DATAWR}}$. Maximum = 5 μs

t_{OH} = Data hold after rising edge of $\overline{\text{DATAWR}}$. Maximum = 2 μs

t_{OD} = Rising edge of $\overline{\text{DATAWR}}$ to falling edge of $\overline{\text{DATARDY}}$. Minimum = 0 μs

Note:

14. These timing specifications given are based on the assumptions that there is no decoding in progress, no status, terminal ID, header or terminator change command is being executed at the time. All the timings assume the IC runs at 12 MHz.

Table 3. Summary of Features and Configuration Control—HBCR-2000 Series

Feature	Function or Value	Hardware/ Software Control ⁽¹⁵⁾	Default Setting ⁽¹⁶⁾
Scanner Type	Contact reader or moving beam laser scanner	Hardware	Moving beam laser scanner
Laser Shutoff Delay	Defines laser on time prior to automatic shutoff from 0 to 10 seconds in 100 ms steps	Software	3 seconds
Laser Redundancy Check	Enables requirement for two consecutive, identical decodes for a good read	Software	Disabled
Scanner Input Enable	Enables data acquisition from the scanner	Software	Enabled
Single Read Mode	Enables requirement for a 'Next Read' command before processing the next scanner input signal	Software	Disabled
Code Select	Extended Code 39	Both	Code 39 Interleaved 2 of 5 UPC/EAN/JAN Codabar Code 128
	Code 39 Interleaved 2 of 5 UPC/EAN/JAN Codes Codabar Code 128	Software	
UPC/EAN/JAN Decoding Options	UPC/EAN/JAN together; or UPC only	Software	UPC/EAN/JAN together
	Enable 2 or 5 digit supplements	Software	Supplements disabled
Codabar Data Transmission Option	Transmit or suppress Start/Stop characters	Software	Transmit
Check Characters	Code 39 check character verification	Both	No verification
	Interleaved 2 of 5 check character verification	Software	
Interleaved 2 of 5 Label Length Check	User Defined from 4 to 32 characters (even only) or variable length	Software	Variable length
Baud Rate	1200, 2400, 4800, 9600	Hardware	1200 Baud
Parity	0's, 1's, Odd, Even	Hardware	0's
Stop Bits	1 or 2	Hardware	1
Terminator Character	CR, CR LF, ETX, None	Hardware	CR
	User defined (10 characters maximum)	Software	
Header Character	User defined (10 characters maximum)	Software	No header character
Data Output Pacing	RTS/CTS	Hardware	No pacing
	XON/XOFF	Software	
Good Read Beep Select	Enables good read beep (1 of 16 tones)	Software	Beep tone = 12
Sound Tone	Command to sound tones (1 of 16)	Software	N/A
LED Control	Controls LED driver circuit	Software	LED to flash upon good read
Status Request	Gives status of decoder IC configuration	Software	N/A
Hard Reset	Resets decoder IC to hardware configuration and default software settings	Software	N/A

Notes:

- 15. Hardware control is accomplished by tying the appropriate input pins high or low. Software commands are sent by means of escape sequences
- 16. Default settings are those settings which result when the relevant pins have been tied to -5V and no software commands have been sent to the Decoder IC

HBCR-2000 Series Pinout

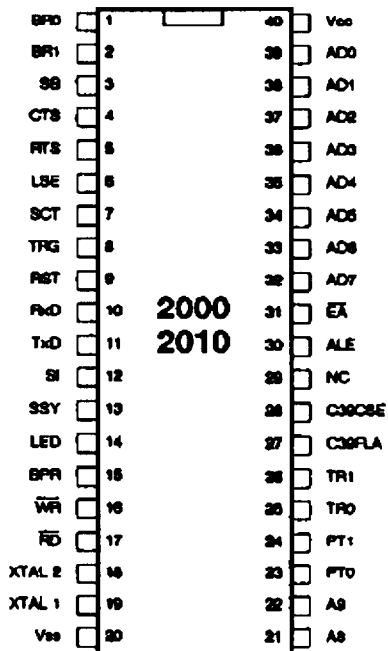

Mnemonic	Description
BR0	Baud Rate Select 0
BR1	Baud Rate Select 1
SB	Stop Bits
PT0	Parity Select 0
PT1	Parity Select 1
TR0	Trailer Select 0
TR1	Trailer Select 1
CTS	Clear to Send
RTS	Request to Send
RxD	Received Data
TxD	Transmitted Data
TRG	Trigger Input
LSE	Laser Scan Enable
SSY	Laser Synchronization
SCT	Scanner Type
LED	LED Control
BPR	Beeper Control
RST	Reset
SI	Scanner Input
NC	No Connect
EA	Connect to +5V
ALE	Address Latch Enable
WR	Memory Write
RD	Memory Read
XTAL 1	Crystal Input 1
XTAL 2	Crystal Input 2
C39FLA	Code 39 Full ASCII Conversion
C39CSE	Code 39 Check Character Enable
AD0-AD7	Address/Data Bits 0-7
A8	Memory Address Line 8
A9	Memory Address Line 9
Vss	Ground
Vcc	+5V Power

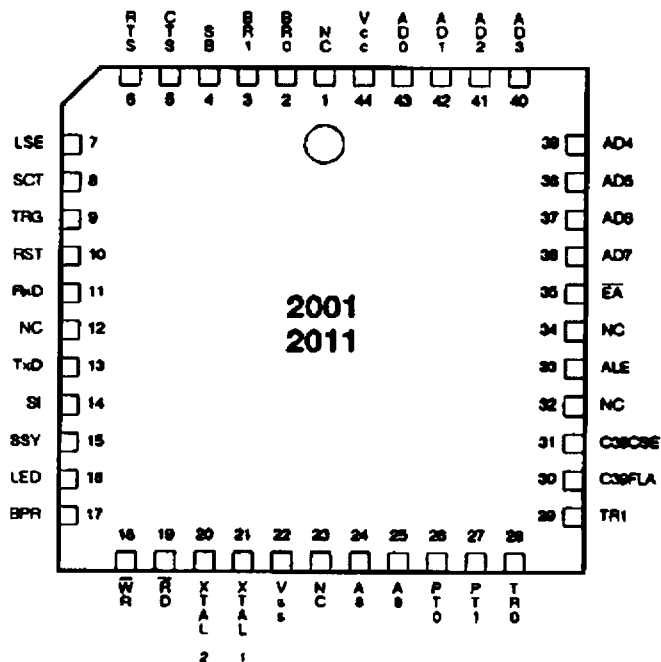

Escape Sequence Summary – All Decoder ICs

Command	Description	Command	Description
<esc> -y <n> B	Good Read Beep Select	<esc> -y <n> O <text>	Trailer Select
<esc> -y <n> C	Industrial Code Select	<esc> -y <n> S	Status Request
<esc> -y <n> D	Checksum Verification Select	<esc> -y <n> T	Sound Tone
<esc> -y <n> L	LED Control	<esc> -y <n> U	UPC/EAN/JAN Options
<esc> -y <n> M	Interleaved 2 of 5 Length Check	<esc> -y <n> W	Scanner Enable
<esc> -y <n> N <text>	Header Select	<esc> -y <n> X	DC1/DC3 Pacing
<esc> E	Hard Reset		

Escape Sequence Summary – HBCR-2000 Series Only

Command	Description	Command	Description
<esc> -y <n> E	Decoding Options	<esc> -y <n> J	Single Read Mode
<esc> -y <n> F	Code Select	<esc> -y <n> K	Next Read
<esc> -y <n> G	Check Character Select	<esc> -y <n> R	Laser Redundancy Check
<esc> -y <n> H	Decoding Options	<esc> -y <n> V	Laser Shutoff Delay

Note: <esc> is the ASCII escape character, 27 decimal, 1B hex

IC Reset Circuits

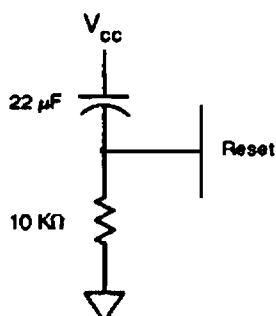

Figure 1. HBCR-1800, -1801, -2000, -2001 ICs

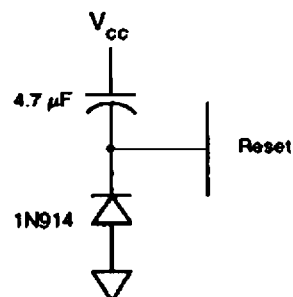

Figure 2. HBCR-1810, -1811, -2010, -2011 ICs

Physical Dimensions

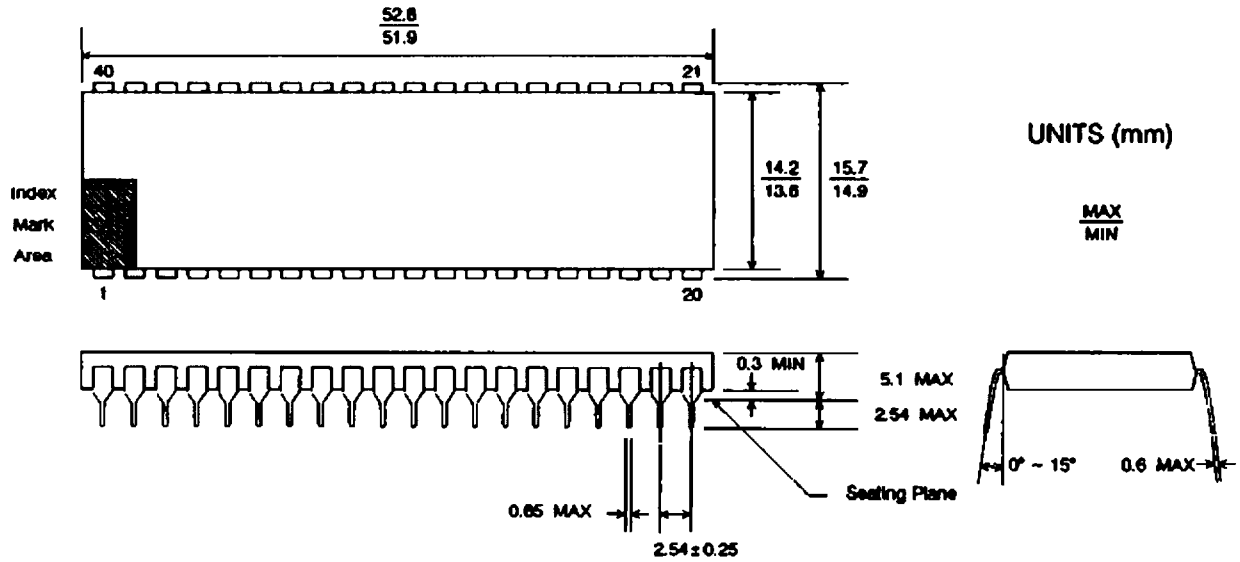

Figure 3. HBCR-1800, -1810, -2000, -2010

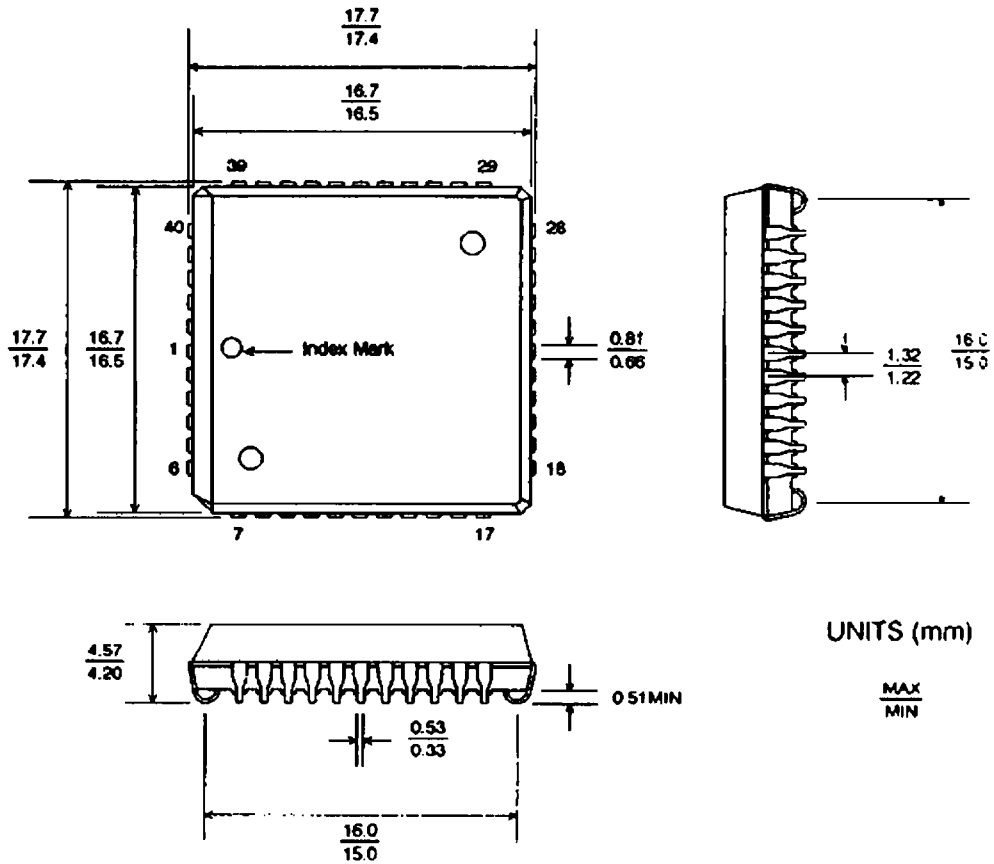

Figure 4. HBCR-1801, -1811, -2001, -2011

PLCC Solder Pad Reference

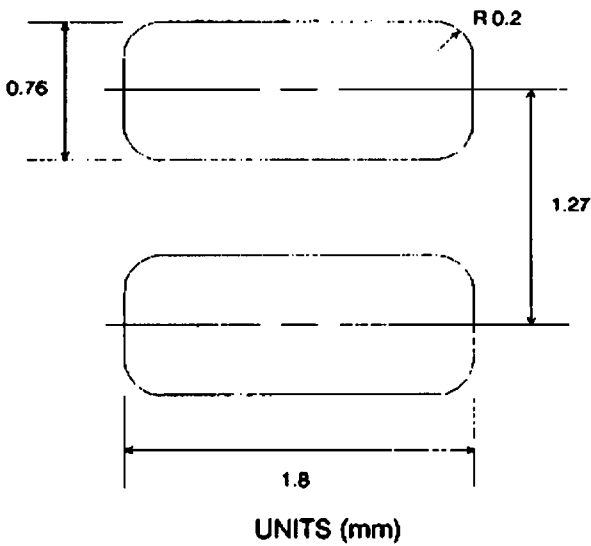

Figure 5. Pad Size

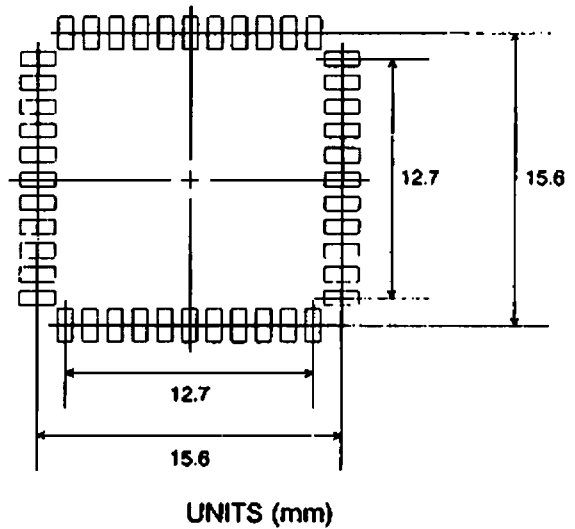

Figure 6. Pad Placement

PLCC Drying

Whenever Vapor Phase or Infrared Reflow technologies are used to mount the PLCC packages, there is a possibility that previously absorbed moisture, heated very rapidly to the reflow temperatures, may cause the package to crack from internal stresses. There is a reliability concern that moisture may then enter the package over a period of time, and metal corrosion may take place, degrading the IC performance.

To reduce the amount of absorbed moisture and prevent cracking, all of the PLCC ICs should undergo one of the following baking cycles. The parts **MUST** then be mounted within 48 hours.

If the parts are not mounted within 48 hours, they **MUST** be rebaked.

The total number of baking cycles must not exceed two (2). If the ICs are baked more than twice, Hewlett-Packard cannot guarantee the performance and reliability of the parts.

Neither bake cycle can be performed in the standard shipping tubes. The ICs must be baked in an ESD safe, mechanically stable container, such as an aluminum tube or pan.

Cycle	Temperature	Time	Notes
A	125°C	24 Hours	
B	60°C	96 Hours	17

Notes:

17. Cycle B must be done in an atmosphere of <5% relative humidity air or nitrogen

Contact Scanner Input Circuit

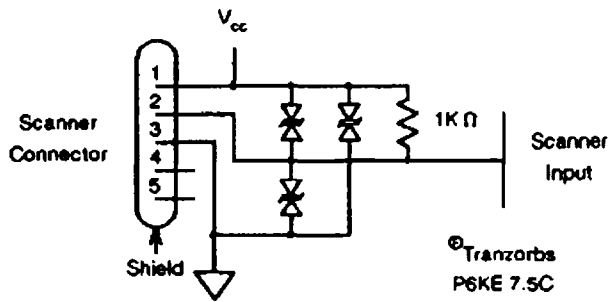

Notes:

- 18. The shield **MUST** be connected to ground for proper scanner operation.
- 19. The \pm TRANZORBs are optional. If the application requires the frequent changing of the scanners they are highly recommended.

TRANZORB is a registered trademark of General Semiconductor Industries Tempe, AZ

Figure 7. Recommended Interface

Moving Beam Scanner Input Circuits — HBCR-2000 Series

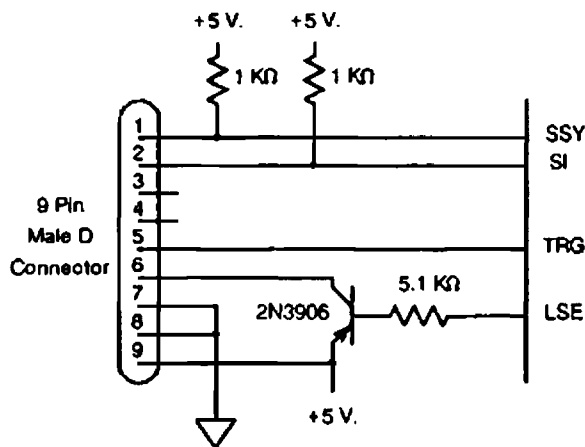

Figure 8. 5 Volt Laser Interface

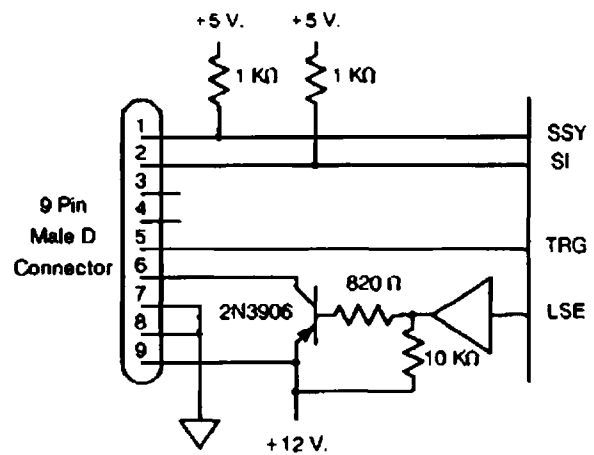

Figure 9. 12 Volt Laser Interface

External Clock Drivers

If an external clock is to be used, the functions of the XTAL1 and XTAL2 pins are different in the NMOS and CMOS ICs

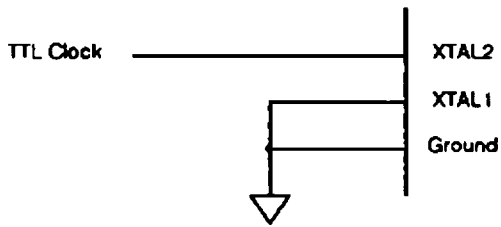

Figure 10. 1800, 1801, 2000, 2001 ICs

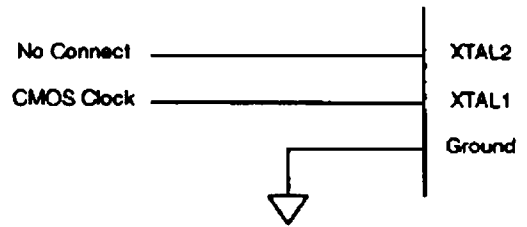

Figure 11. 1810, 1811, 2010, 2011 ICs

Block Diagram

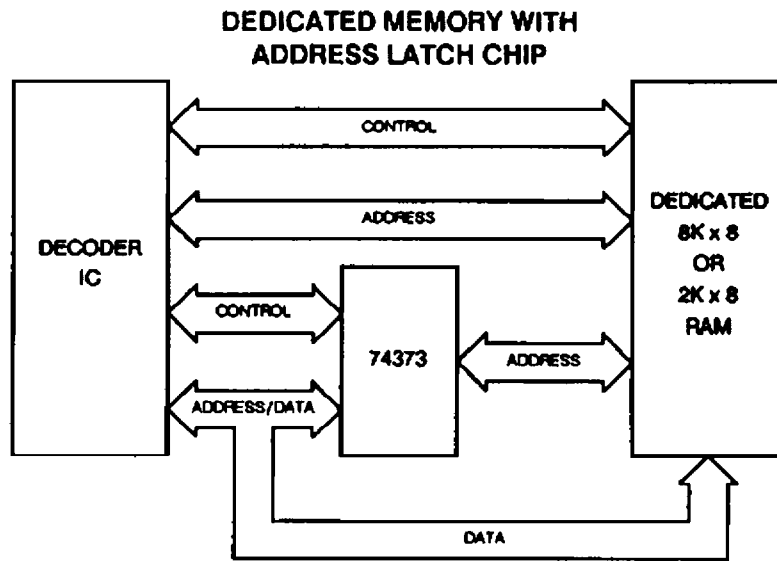

Figure 12.



For more information call your local HP sales office listed in the telephone directory white pages. Ask for the Components Department. Or write to Hewlett-Packard U.S.A. — P.O. Box 10301, Palo Alto, CA 94303-0890. Europe — P.O. Box 988 1180 AZ Amstelveen, The Netherlands. Canada — 6877 Goreway Drive, Mississauga, L4V 1M8, Ontario. Japan — Yokogawa-Hewlett-Packard Ltd., 3-29-21, Takaido-Higashi, Suginami-ku, Tokyo 168. Elsewhere in the world, write to Hewlett-Packard Intercontinental, 3405 Deer Creek Road, Palo Alto, CA 94304.

Data Subject to Change

Printed in U.S.A.

Copyright © 1988 Hewlett-Packard Company

5954-2182 (10/88)