

240PQM-CR



QMA Male for CNT-240 braided cable

Product Classification

Product Type	Braided cable connector
Product Brand	CNT®

General Specifications

Body Style	Straight
Inner Contact Attachment Method	Solder
Inner Contact Plating	Gold
Interface	QMA Male
Outer Contact Attachment Method	Crimp
Outer Contact Plating	Trimetal
Pressurizable	No

Dimensions

Width	10.5 mm 0.413 in
Length	28.66 mm 1.128 in
Diameter	10.5 mm 0.413 in
Nominal Size	0.240 in

Outline Drawing

240PQM-CR

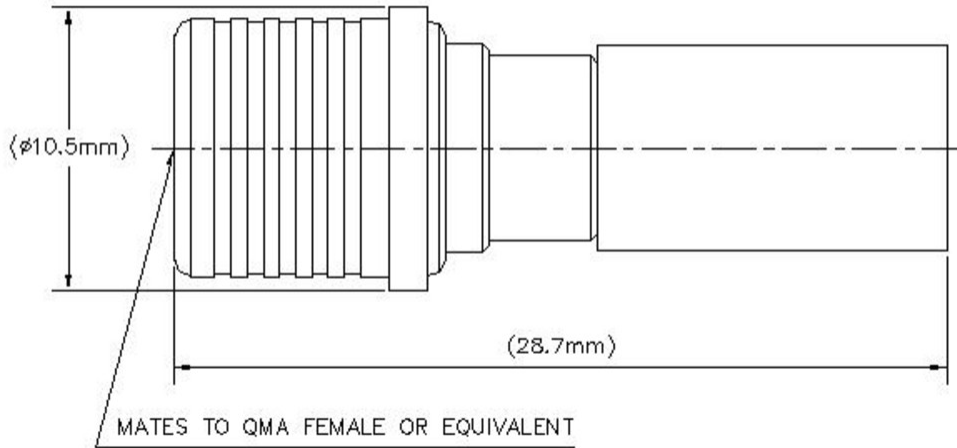

Electrical Specifications

Insertion Loss, typical	0.05 dB
Average Power at Frequency	260.0 W @ 900 MHz
Cable Impedance	50 ohm
Connector Impedance	50 ohm
dc Test Voltage	1000 V
Inner Contact Resistance, maximum	3 mOhm
Insulation Resistance, minimum	5000 MOhm
Operating Frequency Band	0 – 6000 MHz
Outer Contact Resistance, maximum	2.5 mOhm
Peak Power, maximum	5 kW
RF Operating Voltage, maximum (vrms)	500 V

VSWR/Return Loss

Frequency Band	VSWR	Return Loss (dB)
0–3000 MHz	1.05	32.3
3000–6000 MHz	1.082	28.1

Mechanical Specifications

Connector Retention Tensile Force	134 N 30.124 lbf
--	--------------------

240PQM-CR

Connector Retention Torque	0.23 N-m 2.036 in lb
Insertion Force	22 N 4.946 lbf
Insertion Force Method	IEC 61169-15:9.3.5
Interface Durability	100 cycles
Interface Durability Method	IEC 61169-15:9.5
Mechanical Shock Test Method	IEC 60068-2-27

Environmental Specifications

Operating Temperature	-40 °C to +85 °C (-40 °F to +185 °F)
Storage Temperature	-65 °C to +125 °C (-85 °F to +257 °F)
Attenuation, Ambient Temperature	20 °C 68 °F
Average Power, Ambient Temperature	40 °C 104 °F
Average Power, Inner Conductor Temperature	100 °C 212 °F
Climatic Sequence Test Method	IEC 60068-1
Corrosion Test Method	IEC 60068-2-11
Damp Heat Steady State Test Method	IEC 60068-2-3
Thermal Shock Test Method	IEC 60068-2-14
Vibration Test Method	IEC 60068-2-6
Water Jetting Test Mating	Mated
Water Jetting Test Method	IEC 60529:2001, IP65

Packaging and Weights

Weight, net	16 g 0.035 lb
--------------------	-----------------

Regulatory Compliance/Certifications

Agency	Classification
ISO 9001:2015	Designed, manufactured and/or distributed under this quality management system



* Footnotes

Insertion Loss, typical 0.05v⁻¹freq (GHz) (not applicable for elliptical waveguide)