

May 1992

IR Remote-Control Amplifier

Features

- Integrated Circuit Package - 9-Pin SIP
- Excellent Overload Characteristics
- High-Gain Amplifiers
- Schmitt Trigger Switching
- 12 Volt Power Supply
- Low Power Dissipation
- Internal Regulation
- Nominal 100 μ V Sensitivity
- Nominal 50K Input Impedance

Description

The CA3237* is a linear integrated circuit intended for infra-red remote control receiver applications for TV receivers. The sensor for the remote control receiver consists of a photo-diode that senses the 40kHz pulse code modulated control signal from the infrared carrier. The other functional parts of the system include an amplifier-limiter, a narrow band filter, a detector, a Schmitt trigger, and a decoder. The CA3237 provides the amplifier limiter and the Schmitt trigger. The amplifier limiter consists of two stages. Both stages have externally accessible feedback points for external gain programming. Internal voltage regulation is provided.

The CA3237 is supplied in nine lead Single-In-Line Package (SIP). The CA3237 is pin-for-pin compatible with the AN5020.

* Formerly developmental type TA11167

Ordering Information

PART NUMBER	TEMPERATURE RANGE	PACKAGE
CA3237E	-40°C to +85°C	9 Lead Plastic SIP

Pinout

9-LEAD PLASTIC SIP
TOP VIEW

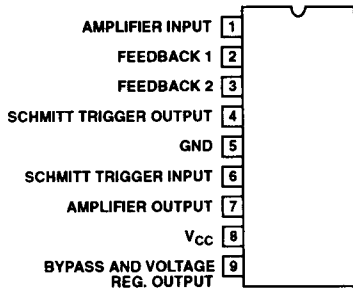

Block Diagram

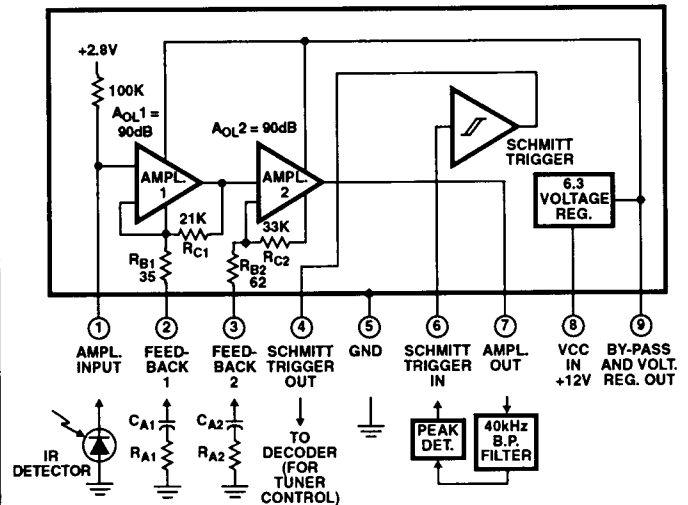

Specifications CA3237

Absolute Maximum Ratings

$T_A = +25^\circ\text{C}$ Unless Otherwise Specified

DC Supply Voltage (V_{CC}) 14.4V

DC Supply Current (I_{CC}) 25mA

Maximum Package Power Dissipation

Up to $T_A = +85^\circ\text{C}$ 360mW

Operating Temperature Range -40°C to $+85^\circ\text{C}$

Storage Temperature Range -55°C to $+150^\circ\text{C}$

Maximum Junction Temperature $+150^\circ\text{C}$

Lead Temperature (During Soldering)

At a distance not less than $1/16"$ (1.59mm) from
case for 10s max $+260^\circ\text{C}$

NOTE: Recommended supply voltage range (VCC) is 9.6V to 14.4V.

CAUTION: Stresses above those listed in "Absolute Maximum Ratings" may cause permanent damage to the device. This is a stress only rating and operation of the device at these or any other conditions above those indicated in the operational sections of this specification is not implied.

Electrical Specifications $T_A = +25^\circ\text{C}$, $V_{CC} = 12\text{V}$, Unless Otherwise Specified. See Figure 2 for Test Circuit

PARAMETERS	TEST CONDITIONS	LIMITS			UNITS
		MIN	TYP	MAX	
DC SPECIFICATIONS, Switch 1 Open, Switch 2 in Position 3 (Input Open)					
Supply Current	$V_{CC} = 14.4\text{V}$	-	6	10	mA
Balance Voltage, Pin 3		-	2.5	-	V
Bias Voltage, Pin 2		-	2.8	-	V
Regulator Voltage, Pin 9		-	6.3	-	V
Op-Amp Bias Voltage, Pin 7		-	-	1.7	V
AC SPECIFICATIONS, Switch 1 Open Unless Otherwise Specified					
Amplifier High Level, (Pin 7 Out)	$V_1 \text{ In} = 5V_{P-P}$, Freq. = 40kHz, Switch 2 in Position 1	2.5	-	-	V_{P-P}
Amplifier Gain ($V_1 \text{ In}$)	Pin 7 Out = 800mV _{P-P} , Freq. = 40kHz, Switch 2 in Position 1	-	-	500	μV_{P-P}
Schmitt Trigger Output Voltage High (Pin 4 Out)	Pin 6 = 1.5V _{DC} , Switch 2 in Position 3 (Input Open)	4	-	5	V _{DC}
Schmitt Trigger Output Voltage Low (Pin 4 Out)	Pin 6 = 0.3V _{DC} , Switch 2 in Position 3 (Input Open)	0	-	0.8	V _{DC}
Schmitt Trigger High Trip Voltage (Pin 6 In)	Pin 4 Out = 4V _{DC} , Switch 2 in Position 3 (Input Open)	-	-	1.3	V _{DC}
Schmitt Trigger Low Trip Voltage (Pin 6 In)	Pin 4 Out = 0.8V _{DC} , Switch 2 in Position 3 (Input Open)	0.5	-	-	V _{DC}
Functional Test (Pin 4 Out)	$V_{CC} = 9.6\text{V}$, 12V or 14.4V, $V_1 \text{ In} = 5V_{P-P}$, Freq. = 40kHz, Switch 1 Closed, Switch 2 in Position 1	2	-	-	V _{DC}
Output Noise (at T.P.A.)	Switch 2 in Position 2 (Input Grounded)	-	-	10	mV _{RMS}

CA3237

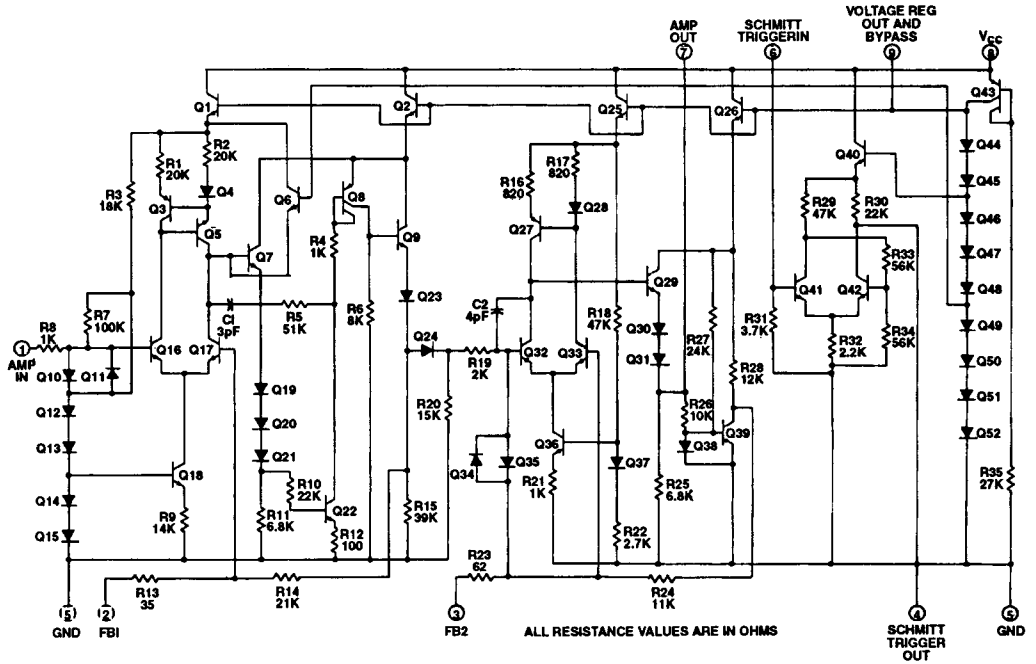

FIGURE 1. SCHEMATIC DIAGRAM FOR CA3237

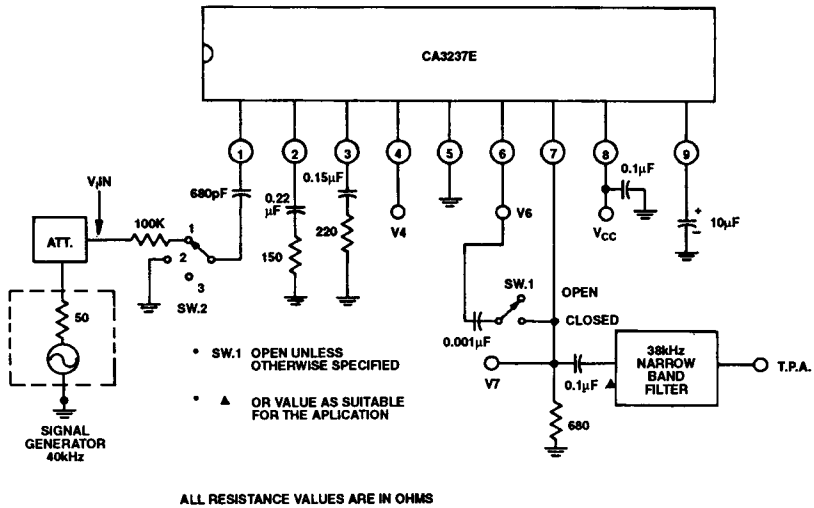

FIGURE 2. TEST CIRCUIT FOR CA3237

General Application

The CA3237 is intended for use in an infrared (IR) remote-control receiver or other comparable application. As shown in Figure 1, this IC consists of two cascaded amplifiers, a Schmitt-trigger circuit, and an internal 6.3-volt regulator. The VCC power-supply input may range from 8 to 14 volts.

Feedback-Amplifier Characteristics

The first amplifier has an open loop gain (A_{OL}) of approximately 90dB, and the second amplifier which is internally cascaded with the first amplifier has an open-loop gain of approximately 60dB. The feedback ratio of the first amplifier is set by the addition of a resistor (R_a) and an isolation capacitor (C_a) at pin 2; the gain of the second amplifier is controlled from pin 3 in the same manner. The closed-loop gain A_{fb} , is determined from the general feedback equation:

$$A_{fb} = A_{OL} / [1 + A_{OL} \times B]$$

where B is the feedback ratio

For the non-inverting amplifier the feedback ratio is given by

$$B = 1 + R_c / (Z_a + R_b)$$

where $Z_a = R_a + 1/j\omega C_a$.

If C_a is sufficiently large Z_a is approximately equal to R_a . For large values of A_{OL} , the closed-loop gain is approximately $1 + R_c / (R_c + R_b)$, a good approximation for the first amplifier. For the second amplifier, which has an A_{OL} of 60dB the closed-loop gain is slightly less than the value given by the simplified approximation.

For the feedback circuit values in the test circuit of Figure 2, the simplified gain equation may be used to calculate the first stage gain as follows:

$$A_{fb1} = 1 + 21k\Omega / (35+150) \Omega = 114.5 = 41.2dB$$

This numerical gain corresponds to 41.2 dB.

For the second stage, and using the same approximation, the gain is calculated to be

$$A_{fb2} = 1 + 33 k\Omega / (62+220) \Omega = 118 \text{ or } 41.4dB.$$

The total gain from pin 1 to the pin 7 output is

$$\text{Gain} = 41.2+41.4=82.6dB$$

The worst-case conditions allow for Z_{in} and A_{OL} variations. The gain specification from the Electrical Characteristic table is 0.8V for 500 μ V input. This specification dictates a minimum gain of 1600 (or 64dB) minimum, including input attenuation losses due to the 100-kilohm source resistor. The Figure 2 circuit is specified as a test condition, but is not a limited use of the CA3237. Using circuit layout care and some shielding, it is possible to achieve over 90dB of stable gain.

Amplifier Input/Output Impedance

The input impedance of the first amplifier is typically 50 kilohm and is the combination of the internal 100-kilohm biasing resistor and the input impedance of the first amplifier stage.

If the source impedance of the signal source is high compared to the input impedance of the amplifier, there will be a proportional attenuation at the input signal. For the Figure 2 test circuit, the source impedance is 100 kilohm and the input loss is typically 9dB.

The output drive signal from the second amplifier (at pin 7) is from the emitter follower Q29 and series Q30 and Q31, shown in Figure 1. As shown in the test circuit of Figure 2, it is possible to stiffen the source impedance by additional dc loading at pin 7. It is recommended that the output load be greater than 500 Ω .

Amplifier Limiting and Bandwidth

The amplifiers are designed to provide signal limiting over a wide dynamic range with little effect on the duty cycle. In the IC circuit diagram of Figure 1, the Q10 and Q11 back-to-back diodes limit the peak-to-peak drive; additional control is provided by the Q6 emitter at the output of the first differential stage. Limiting starts as low as 50 μ V. The limiting range continues to a level greater than 1 volt of signal-input capability with typically less than 10% change in duty cycle.

The bandwidth characteristic of the CA3237 is matched to the 40kHz center frequency range commonly used by IR remote systems. For this reason, the roll-off characteristic of the amplifier is optimized for use in the 10kHz to 100kHz area. The 3dB linear signal roll-off is approximately 70kHz and is controlled by internal compensating capacitors on the chip. However, the circuit may function as a limiting-amplifier up to frequencies as high as 1MHz.

Schmitt-Trigger Circuit

The Schmitt trigger is designed to provide a digitally switched signal from a peak detected burst. Use of the Schmitt trigger is recommended as a means of shaping the detected signal at pin 7 before it is input to a decoder circuit.

It is important to note that the Schmitt trigger input has 3.7 kilohm input impedance but drops to a much lower value when the input transistor switches to saturation. The low impedance provides noise immunity during the low (OFF) state. In Figure 1, transistor Q41 and Q42 form the differential switching circuit. The threshold for switching at pin 6 is approximately 1 volt (ON) and 0.8 volt (OFF). The bias supply for the switching differential is determined by the internally regulated supply, which is tapped at 4.2 volts on the stack of reference diodes.

IR Remote Amplifier Application

The circuit diagram of Figure 3 shows a typical application as an IR remote control receiver. The biased IR detector receives transmitted impulses from the remote unit, from which the signal is ac coupled into pin 1 of the CA3237. An optional variation of feedback control of gain is used at pin 3 making the gain of the second stage 50dB.

The amplified signal output at pin 7 goes to the transistor Q1 which acts as buffer to drive a tuned high Q transformer. The

selectivity of this circuit provides noise immunity and rejection of unwanted signals. The signal is normally transmitted in 40kHz pulse bursts, such as illustrated in the waveforms of Figure 3a. This circuit illustrates only one of many possible pulse-code-modulation methods used for data transmission. As many as 20 pulses, 25µs in width, form a burst. The detected burst is one bit of pulse code data. After the first pulse code, a "1" or "0" state is determined by the sequential order of the pulse-code data shown.

In Figure 3, the detection of the pulse code bit is done with a diode peak-detector circuit following the tuned transformer.

The waveforms of Figure 3b illustrate the CA3237 signal. The pin 1 waveform is an IR signal burst and, in this case, is shown as the modulation signal. The output signal at pin 7 is the burst signal with a background level of noise when the burst is not present. The detected signal that is returned to the pin 6 input of the Schmitt trigger is a diode/RC integrated pulse with an exponential rise and fall edge. The saturated switch of the Schmitt trigger has low impedance and clamps the positive edge of the detected pulse. The waveform at pin 4 is the Schmitt trigger output with squared edges, and is 5 volt logic compatible to TTL and CMOS.

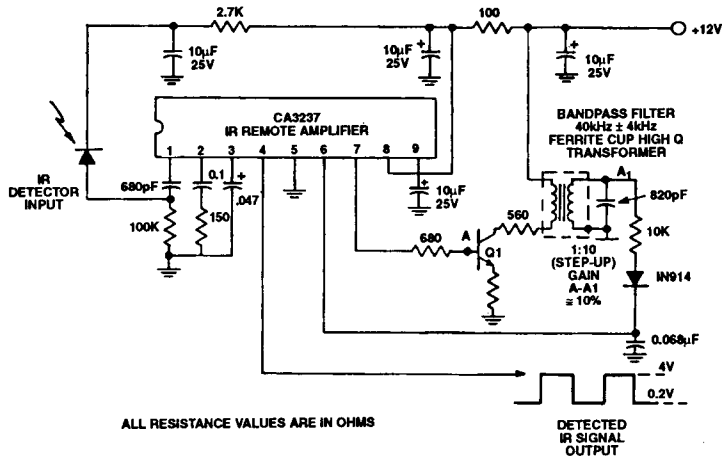

FIGURE 3. TYPICAL IR-REMOTE AMPLIFIER APPLICATION CIRCUIT

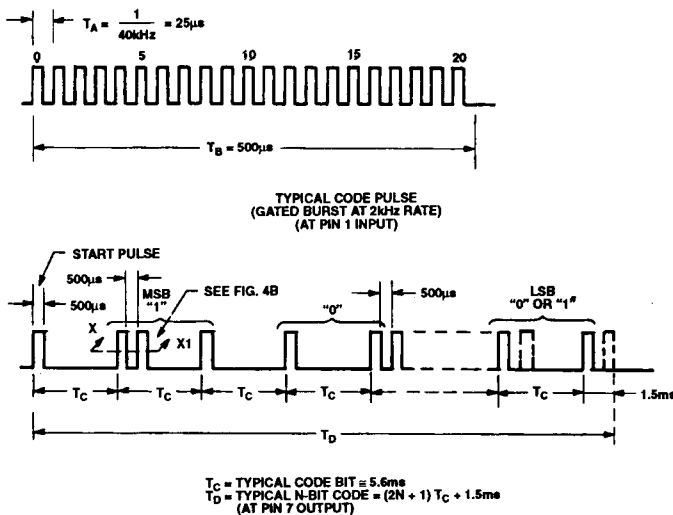

FIGURE 3(a). TYPICAL CODE DATA CONSTRUCTION FOR PULSE CODE MODULATION

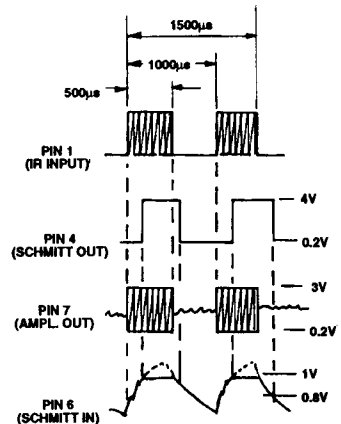

FIGURE 3(b). X-X' WAVEFORMS DETAIL, SEE FIGURE 4a