

TIBPAL16L8-5C, TIBPAL16R4-5C, TIBPAL16R6-5C, TIBPAL16R8-5C
 TIBPAL16L8-7M, TIBPAL16R4-7M, TIBPAL16R6-7M, TIBPAL16R8-7M
 HIGH-PERFORMANCE *IMPACT-X*TM PAL[®] CIRCUITS

SRPS011D - D3359, OCTOBER 1989 - REVISED SEPTEMBER 1992

- **High-Performance Operation:**
 - f_{max} (no feedback)
 - TIBPAL16R' -5C Series ... 125 MHz Min
 - TIBPAL16R' -7M Series ... 100 MHz Min
 - f_{max} (internal feedback)
 - TIBPAL16R' -5C Series ... 125 MHz Min
 - TIBPAL16R' -7M Series ... 100 MHz Min
 - f_{max} (external feedback)
 - TIBPAL16R' -5C Series ... 117 MHz Min
 - TIBPAL16R' -7M Series ... 74 MHz Min
 - Propagation Delay
 - TIBPAL16L8-5C Series ... 5 ns Max
 - TIBPAL16L8-7M Series ... 7 ns Max
 - TIBPAL16R' -5C Series (CLK-to-Q) ... 4 ns Max
 - TIBPAL16R' -7M Series (CLK-to-Q) ... 6.5 ns Max

- Functionally Equivalent, but Faster than, Existing 20-Pin PLDs
- Preload Capability on Output Registers Simplifies Testing
- Power-Up Clear on Registered Devices (All Register Outputs are Set Low, but Voltage Levels at the Output Pins Go High)
- Package Options Include Both Plastic and Ceramic Chip Carriers in Addition to Plastic and Ceramic DIPs
- Security Fuse Prevents Duplication

DEVICE	I INPUTS	3-STATE O OUTPUTS	REGISTERED Q OUTPUTS	I/O PORTS
'PAL16L8	10	2	0	6
'PAL16R4	8	0	4 (3-state buffers)	4
'PAL16R6	8	0	6 (3-state buffers)	2
'PAL16R8	8	0	8 (3-state buffers)	0

TIBPAL16L8'
 C SUFFIX ... J OR N PACKAGE
 M SUFFIX ... J PACKAGE

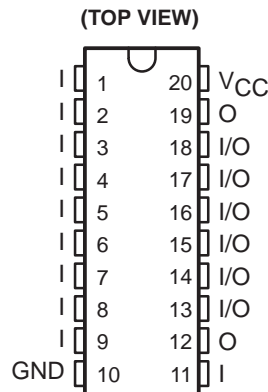

TIBPAL16L8'
 C SUFFIX ... FN PACKAGE
 M SUFFIX ... FK PACKAGE

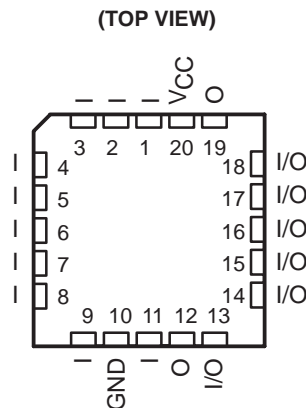

Pin assignments in operating mode

description

These programmable array logic devices feature high speed and functional equivalency when compared with currently available devices. These *IMPACT-X*TM circuits combine the latest Advanced Low-Power Schottky technology with proven titanium-tungsten fuses to provide reliable, high-performance substitutes for conventional TTL logic. Their easy programmability allows for quick design of custom functions and typically results in a more compact circuit board.

The TIBPAL16' C series is characterized from 0°C to 75°C. The TIBPAL16' M series is characterized for operation over the full military temperature range of -55°C to 125°C.

These devices are covered by U.S. Patent 4,410,987.
 IMPACT-X is a trademark of Texas Instruments Incorporated.
 PAL is a registered trademark of Advanced Micro Devices Inc.

This document contains information on products in more than one phase of development. The status of each device is indicated on the page(s) specifying its electrical characteristics.



TIBPAL16R4-5C, TIBPAL16R6-5C, TIBPAL16R8-5C
 TIBPAL16R4-7M, TIBPAL16R6-7M, TIBPAL16R8-7M
 HIGH-PERFORMANCE *IMPACT-X*TM PAL[®] CIRCUITS

SRPS011D - D3359, OCTOBER 1989 - REVISED SEPTEMBER 1992

TIBPAL16R4'
 C SUFFIX ... J OR N PACKAGE
 M SUFFIX ... J PACKAGE

(TOP VIEW)

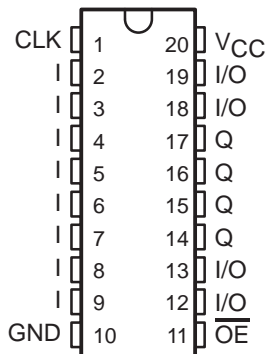

TIBPAL16R4'
 C SUFFIX ... FN PACKAGE
 M SUFFIX ... FK PACKAGE

(TOP VIEW)

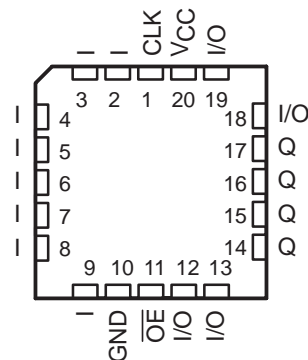

TIBPAL16R6'
 C SUFFIX ... J OR N PACKAGE
 M SUFFIX ... J PACKAGE

(TOP VIEW)

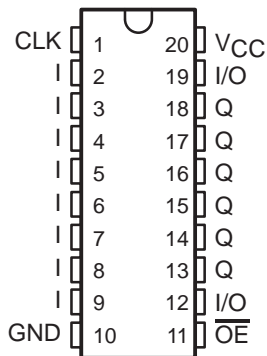

TIBPAL16R6'
 C SUFFIX ... FN PACKAGE
 M SUFFIX ... FK PACKAGE

(TOP VIEW)

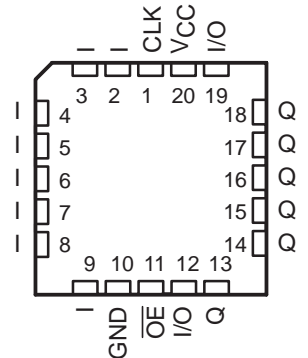

TIBPAL16R8'
 C SUFFIX ... J OR N PACKAGE
 M SUFFIX ... J PACKAGE

(TOP VIEW)

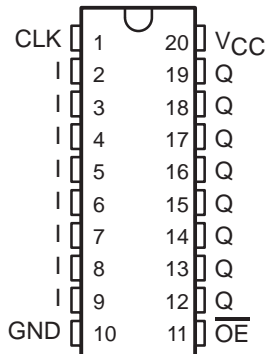

TIBPAL16R8'
 C SUFFIX ... FN PACKAGE
 M SUFFIX ... FK PACKAGE

(TOP VIEW)

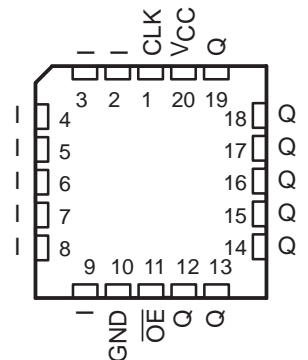

Pin assignments in operating mode

TIBPAL16L8-5C, TIBPAL16R4-5C
 TIBPAL16L8-7M, TIBPAL16R4-7M
 HIGH-PERFORMANCE *IMPACT-X*™ PAL® CIRCUITS

SRPS011D - D3359, OCTOBER 1989 - REVISED SEPTEMBER 1992

functional block diagrams (positive logic)

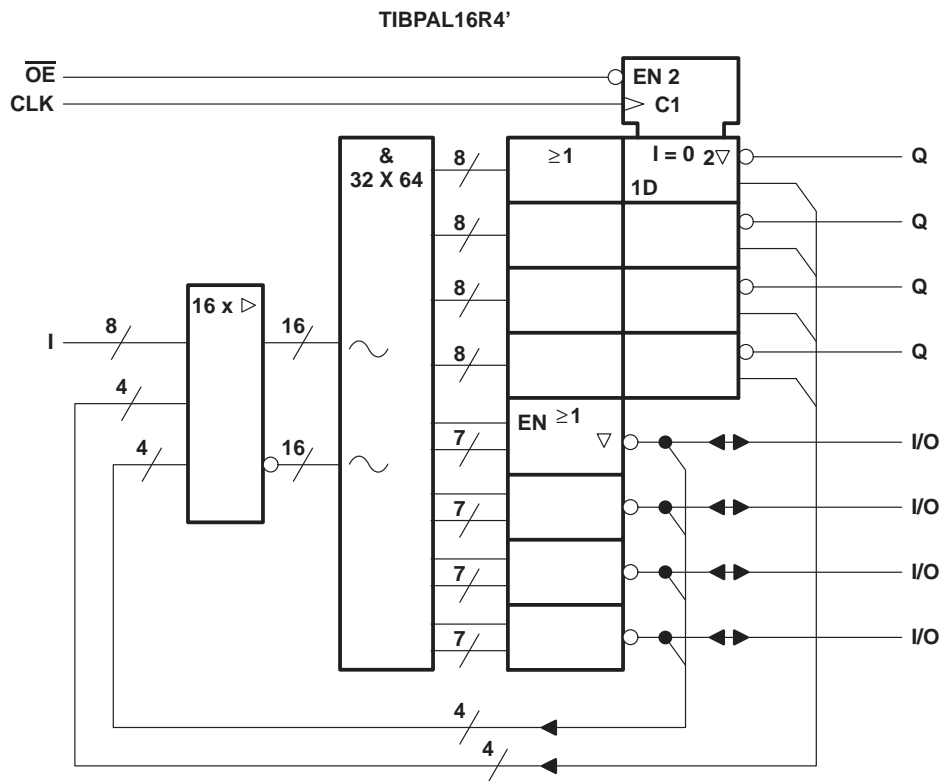
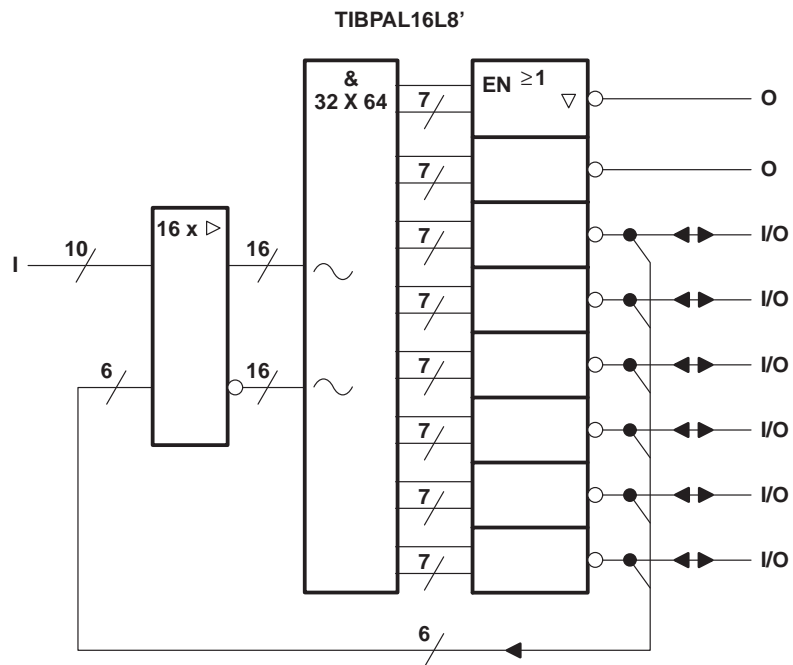

~ denotes fused inputs

TIBPAL16R6-5C, TIBPAL16R8-5C
 TIBPAL16R6-7M, TIBPAL16R8-7M
 HIGH-PERFORMANCE *IMPACT-X*™ PAL® CIRCUITS
 SRPS011D - D3359, OCTOBER 1989 - REVISED SEPTEMBER 1992

functional block diagrams (positive logic)

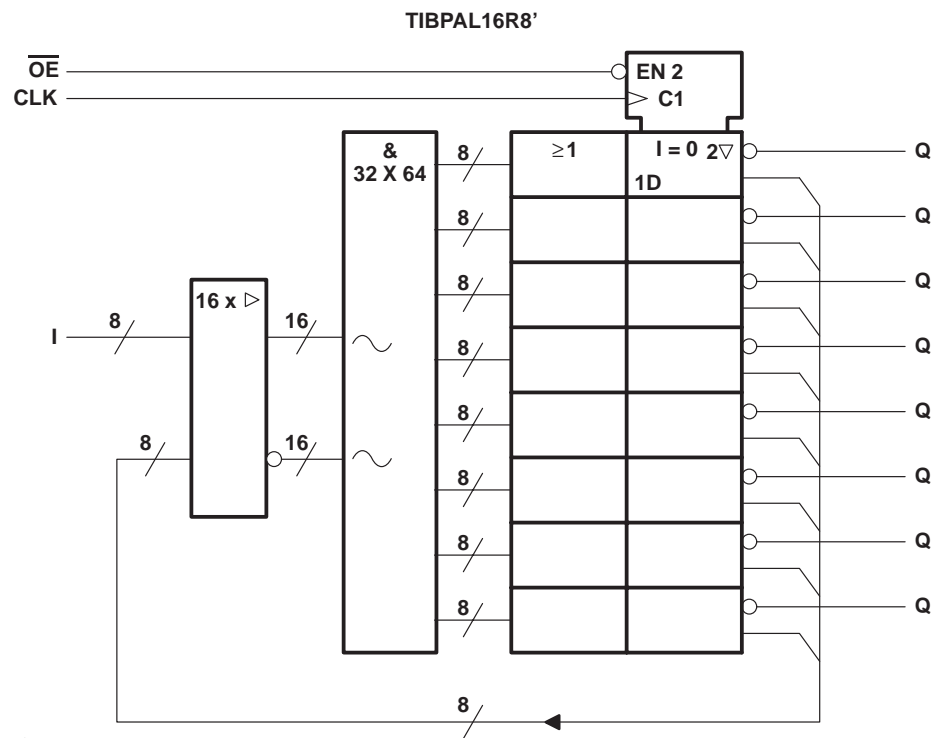
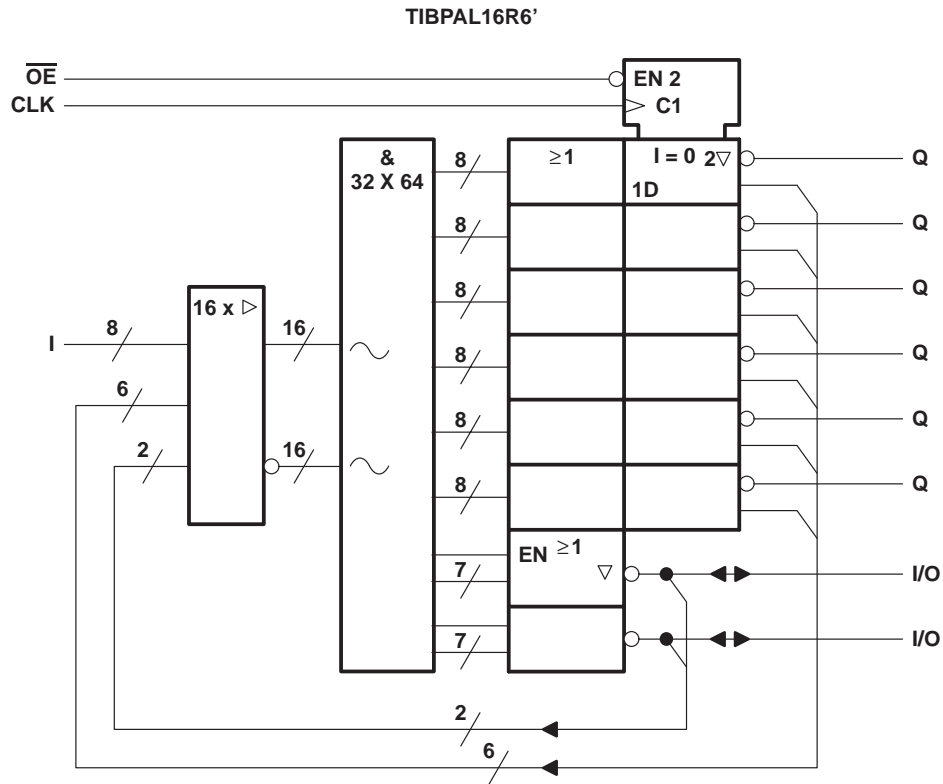

~ denotes fused inputs

logic diagram (positive logic)

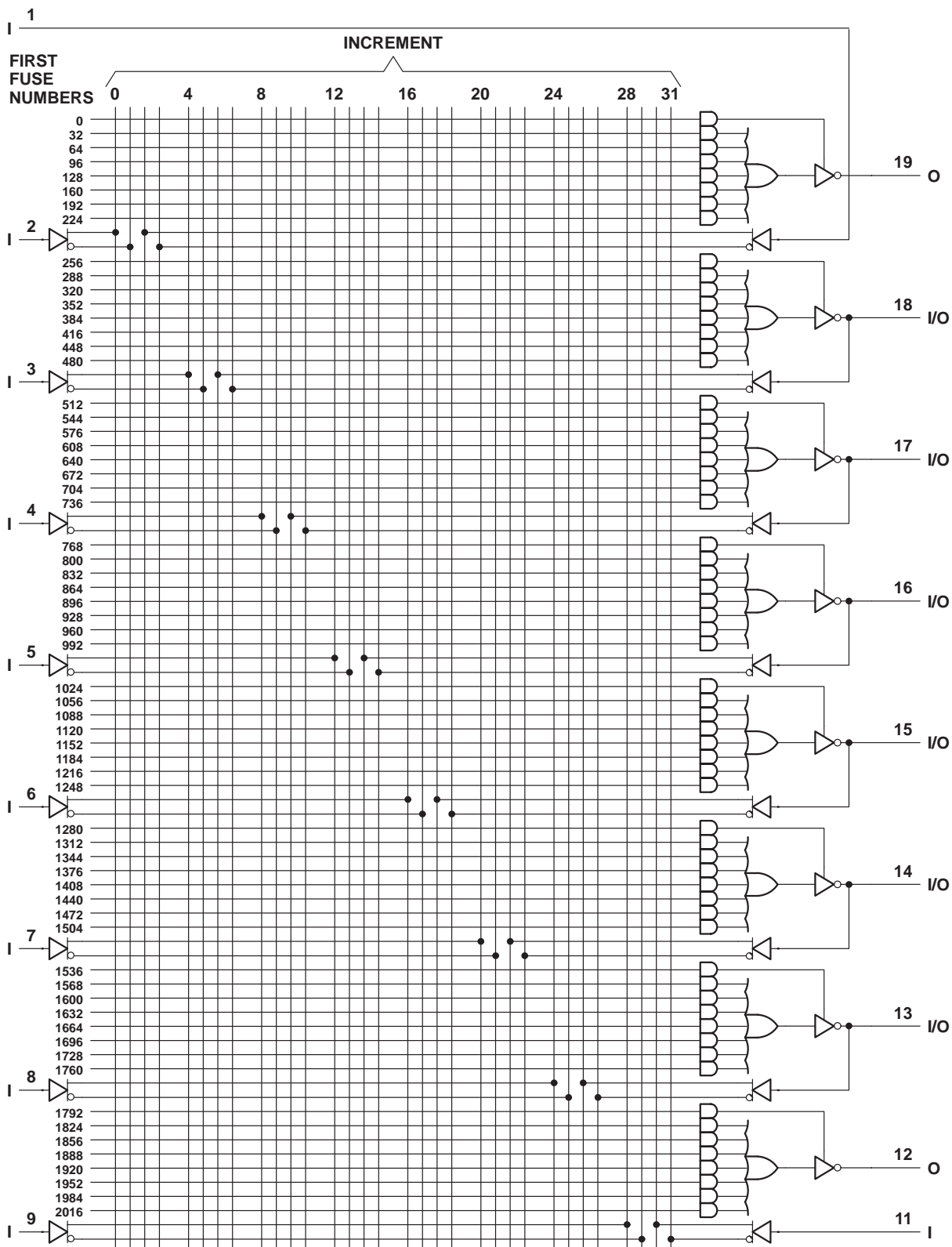

Fuse number = First fuse number + Increment

TIBPAL16R4-5C

TIBPAL16R4-7M

HIGH-PERFORMANCE *IMPACT-X*™ PAL® CIRCUITS

SRPS011D - D3359, OCTOBER 1989 - REVISED SEPTEMBER 1992

logic diagram (positive logic)

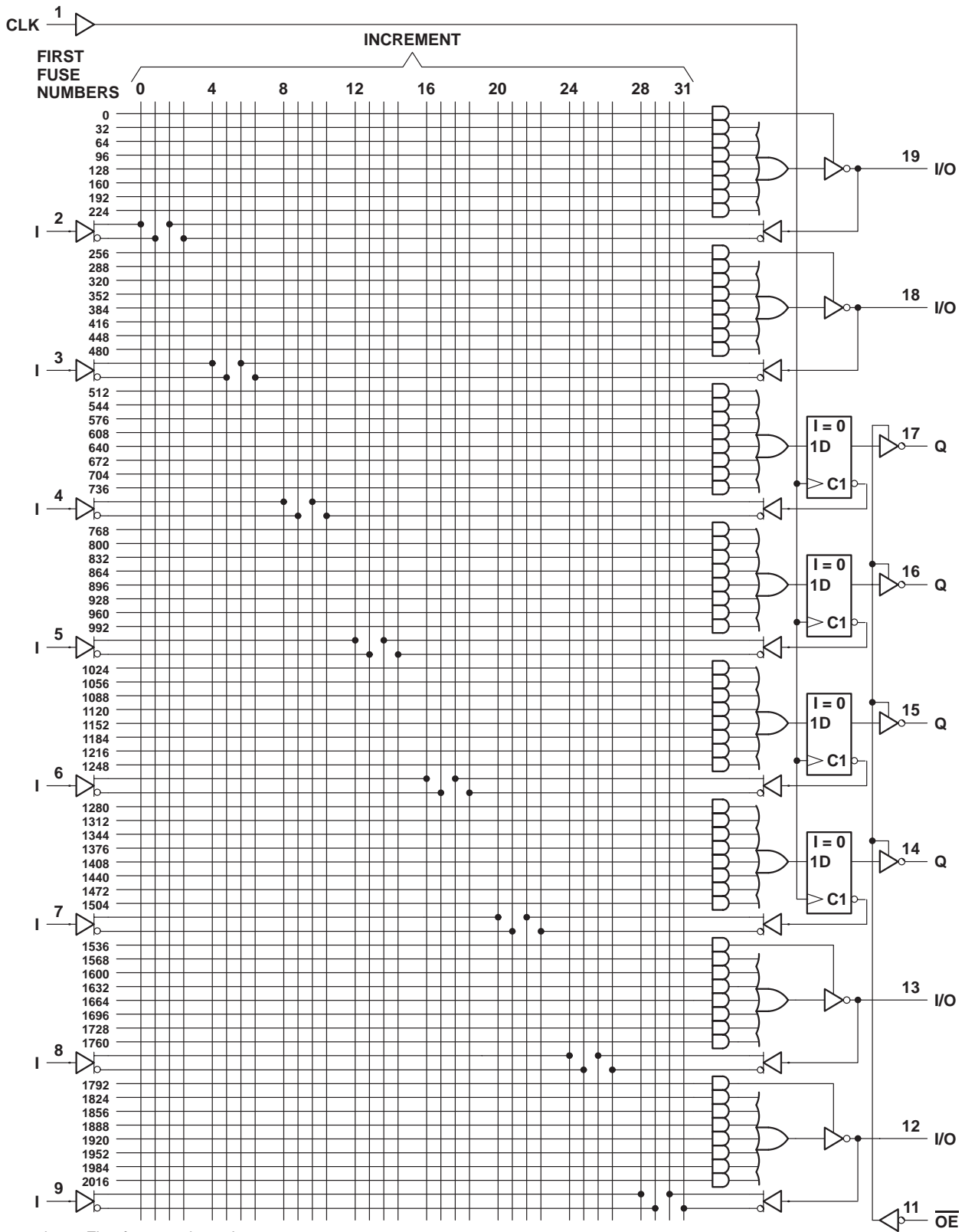

Fuse number = First fuse number + Increment



POST OFFICE BOX 655303 • DALLAS, TEXAS 75265

logic diagram (positive logic)

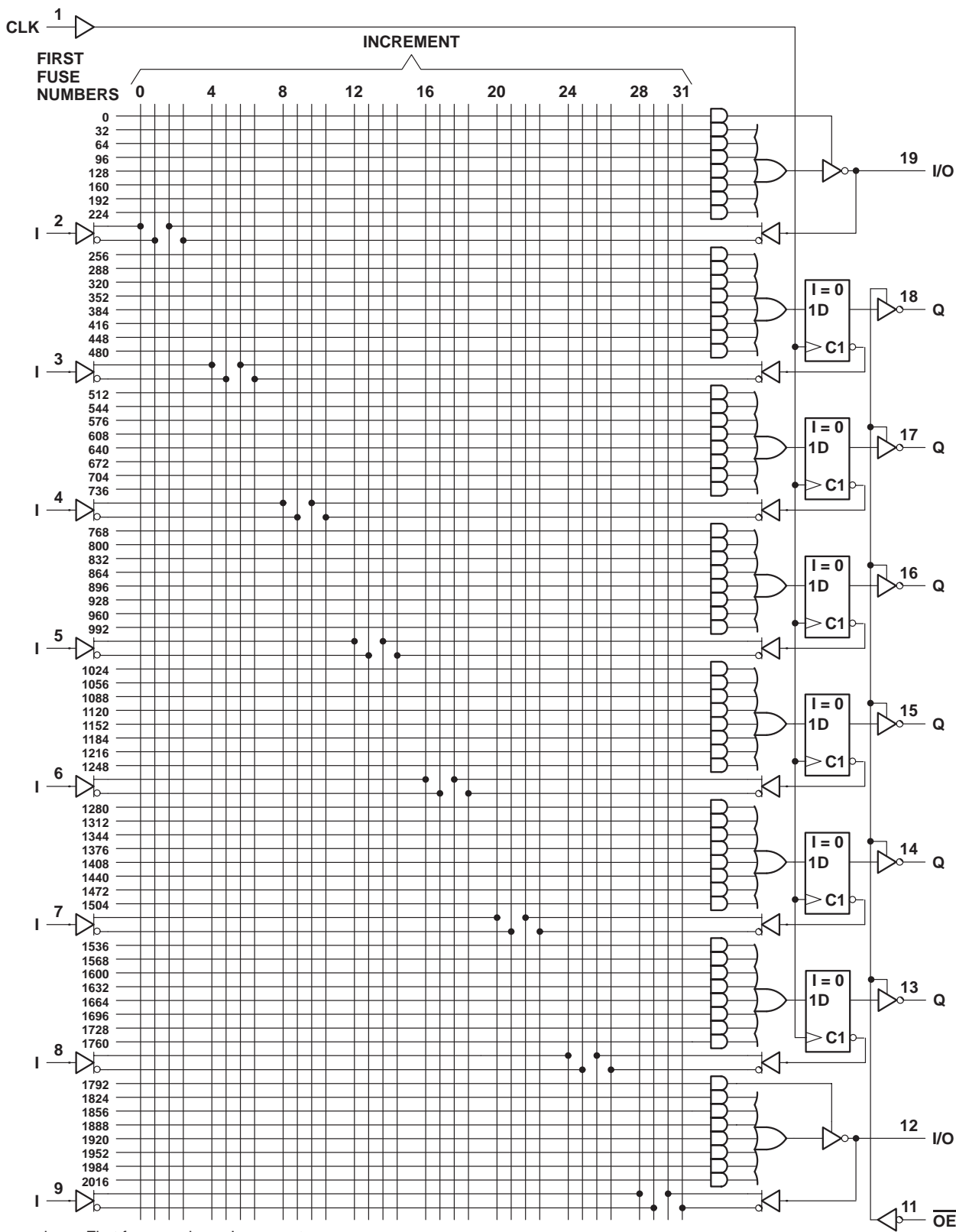

Fuse number = First fuse number + Increment

TIBPAL16R8-5C

TIBPAL16R8-7M

HIGH-PERFORMANCE *IMPACT-X*™ PAL® CIRCUITS

SRPS011D - D3359, OCTOBER 1989 - REVISED SEPTEMBER 1992

logic diagram (positive logic)

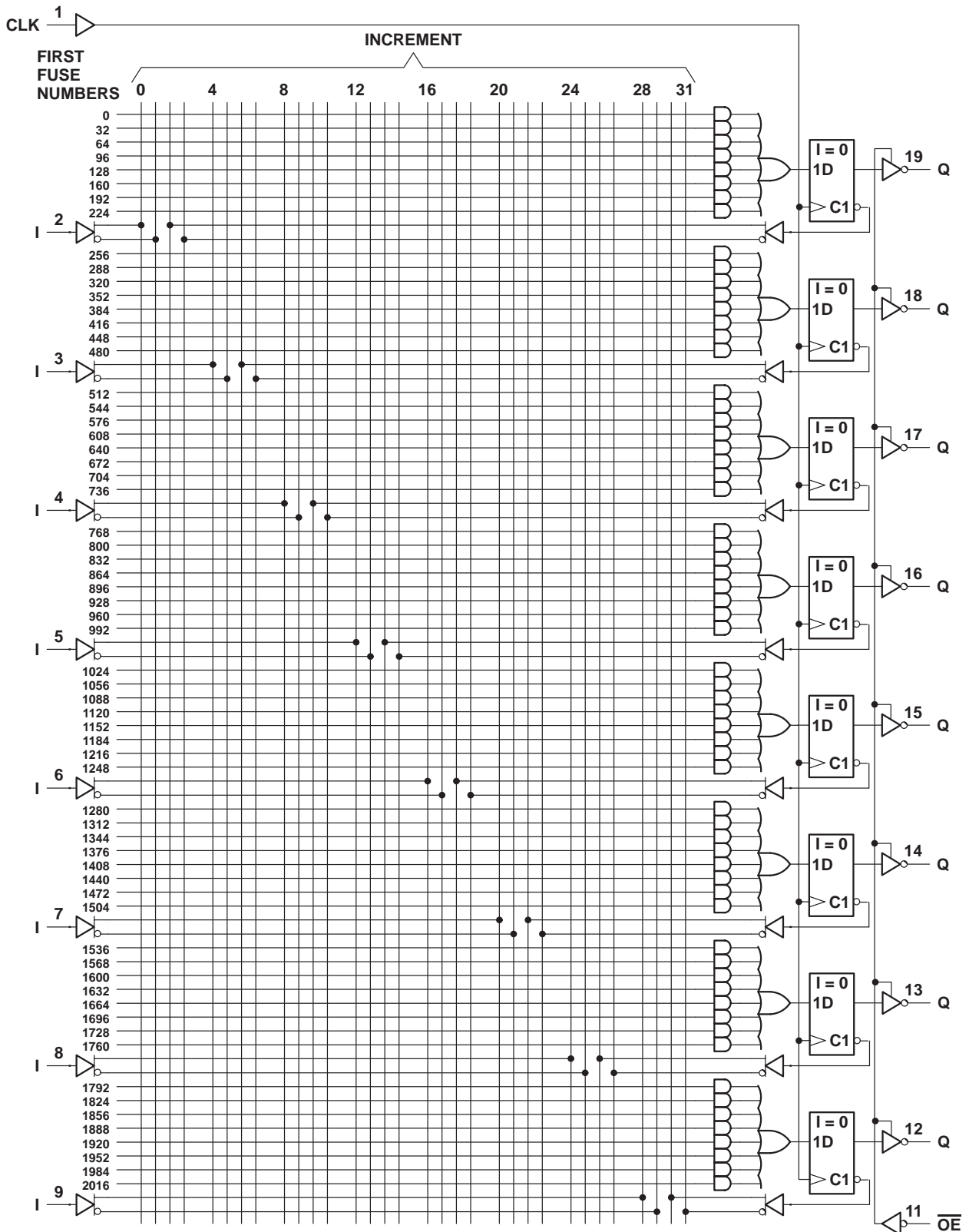

Fuse number = First fuse number + Increment



absolute maximum ratings over operating free-air temperature range (unless otherwise noted)

Supply voltage, V_{CC} (see Note 1)	7 V
Input voltage (see Note 1)	5.5 V
Voltage applied to disabled output (see Note 1)	5.5 V
Operating free-air temperature range	0°C to 75°C
Storage temperature range	–65°C to 150°C

NOTE 1: These ratings apply except for programming pins during a programming cycle or during a preload cycle.

recommended operating conditions

	MIN	NOM	MAX	UNIT
V_{CC} Supply voltage	4.75	5	5.25	V
V_{IH} High-level input voltage (see Note 2)	2		5.5	V
V_{IL} Low-level input voltage (see Note 2)			0.8	V
I_{OH} High-level output current			–3.2	mA
I_{OL} Low-level output current			24	mA
T_A Operating free-air temperature	0	25	75	°C

NOTE 2: These are absolute voltage levels with respect to the ground pin of the device and include all overshoots due to system and/or tester noise. Testing these parameters should not be attempted without suitable equipment.

electrical characteristics over recommended operating free-air temperature range

PARAMETER	TEST CONDITIONS		MIN	TYP†	MAX	UNIT
V_{IK}	$V_{CC} = 4.75$ V,	$I_I = -18$ mA		–0.8	–1.5	V
V_{OH}	$V_{CC} = 4.75$ V,	$I_{OH} = -3.2$ mA	2.4	2.7		V
V_{OL}	$V_{CC} = 4.75$ V,	$I_{OL} = 24$ mA		0.3	0.5	V
$I_{OZH}‡$	$V_{CC} = 5.25$ V,	$V_O = 2.7$ V			100	μA
$I_{OZL}‡$	$V_{CC} = 5.25$ V,	$V_O = 0.4$ V			–100	μA
I_I	$V_{CC} = 5.25$ V,	$V_I = 5.5$ V			100	μA
$I_{IH}‡$	$V_{CC} = 5.25$ V,	$V_I = 2.7$ V			25	μA
$I_{IL}‡$	$V_{CC} = 5.25$ V,	$V_I = 0.4$ V			–250	μA
$I_{OS}§$	$V_{CC} = 5.25$ V,	$V_O = 0.5$ V	–30	–70	–130	mA
I_{CC}	$V_{CC} = 5.25$ V,	$V_I = 0$, Outputs open			180	mA
C_i	$f = 1$ MHz,	$V_I = 2$ V		8.5		pF
C_o	$f = 1$ MHz,	$V_O = 2$ V		10		pF

† All typical values are at $V_{CC} = 5$ V, $T_A = 25^\circ\text{C}$.

‡ I/O leakage is the worst case of I_{OZL} and I_{IL} or I_{OZH} and I_{IH} , respectively.

§ Not more than one output should be shorted at a time, and the duration of the short circuit should not exceed one second. V_O is set at 0.5 V to avoid test problems caused by test equipment ground degradation.

switching characteristics over recommended ranges of supply voltage and operating free-air temperature (unless otherwise noted)

PARAMETER	FROM (INPUT)	TO (OUTPUT)	TEST CONDITIONS	TIBPAL16L8-5CFN		TIBPAL16L8-5CJ TIBPAL16L8-5CN		UNIT
				MIN	MAX	MIN	MAX	
t_{pd}	I, I/O	O, I/O with up to 4 outputs switching	R1 = 200 Ω, R2 = 200 Ω, See Figure 8	1.5	5	1.5	5	ns
	I, I/O	O, I/O with more than 4 outputs switching		1.5	5	1.5	5.5	
t_{en}	I, I/O	O, I/O		2	7	2	7	ns
t_{dis}	I, I/O	O, I/O		2	7	2	7	ns

PRODUCTION DATA information is current as of publication date. Products conform to specifications per the terms of Texas Instruments standard warranty. Production processing does not necessarily include testing of all parameters.

TIBPAL16R4-5C, TIBPAL16R6-5C

HIGH-PERFORMANCE *IMPACT-X*™ *PAL*® CIRCUITS

SRPS011D – D3359, OCTOBER 1989 – REVISED SEPTEMBER 1992

absolute maximum ratings over operating free-air temperature range (unless otherwise noted)

Supply voltage, V_{CC} (see Note 1)	7 V
Input voltage (see Note 1)	5.5 V
Voltage applied to disabled output (see Note 1)	5.5 V
Operating free-air temperature range	0°C to 75°C
Storage temperature range	–65°C to 150°C

NOTE 1: These ratings apply except for programming pins during a programming cycle or during a preload cycle.

recommended operating conditions

		MIN	NOM	MAX	UNIT
V_{CC}	Supply voltage	4.75	5	5.25	V
V_{IH}	High-level input voltage (see Note 2)	2		5.5	V
V_{IL}	Low-level input voltage (see Note 2)			0.8	V
I_{OH}	High-level output current			–3.2	mA
I_{OL}	Low-level output current			24	mA
f_{clock}	Clock frequency	0		125	MHz
t_w	Pulse duration, clock	High	4		ns
		Low	4		
t_{su}	Setup time, input or feedback before clock↑	4.5			ns
t_h	Hold time, input or feedback after clock↑	0			ns
T_A	Operating free-air temperature	0	25	75	°C

NOTE 2: These are absolute voltage levels with respect to the ground pin of the device and include all overshoots due to system and/or tester noise. Testing these parameters should not be attempted without suitable equipment.

TIBPAL16R4-5C, TIBPAL16R6-5C HIGH-PERFORMANCE *IMPACT-X*™ *PAL*® CIRCUITS

SRPS011D – D3359, OCTOBER 1989 – REVISED SEPTEMBER 1992

electrical characteristics over recommended operating free-air temperature range

PARAMETER		TEST CONDITIONS		MIN	TYP†	MAX	UNIT
V_{IK}		$V_{CC} = 4.75\text{ V}$,	$I_I = -18\text{ mA}$		-0.8	-1.5	V
V_{OH}		$V_{CC} = 4.75\text{ V}$,	$I_{OH} = -3.2\text{ mA}$	2.4	2.7		V
V_{OL}		$V_{CC} = 4.75\text{ V}$,	$I_{OL} = 24\text{ mA}$		0.3	0.5	V
$I_{OZH}‡$		$V_{CC} = 5.25\text{ V}$,	$V_O = 2.7\text{ V}$			100	μA
$I_{OZL}‡$		$V_{CC} = 5.25\text{ V}$,	$V_O = 0.4\text{ V}$			-100	μA
I_I		$V_{CC} = 5.25\text{ V}$,	$V_I = 5.5\text{ V}$			100	μA
$I_{IH}‡$		$V_{CC} = 5.25\text{ V}$,	$V_I = 2.7\text{ V}$			25	μA
$I_{IL}‡$		$V_{CC} = 5.25\text{ V}$,	$V_I = 0.4\text{ V}$			-250	μA
$I_{OS}§$		$V_{CC} = 5.25\text{ V}$,	$V_O = 0.5\text{ V}$	-30	-70	-130	mA
I_{CC}		$V_{CC} = 5.25\text{ V}$,	$V_I = 0$, Outputs open			200	mA
C_i	I	f = 1 MHz,	$V_I = 2\text{ V}$				pF
	CLK/OE			7			
C_o	I/O	f = 1 MHz,	$V_O = 2\text{ V}$				pF
	Q			10			
					5		
					7		

switching characteristics over recommended ranges of supply voltage and operating free-air temperature (unless otherwise noted)

PARAMETER	FROM (INPUT)	TO (OUTPUT)	TEST CONDITIONS	TIBPAL16R4-5CFN TIBPAL16R6-5CFN			TIBPAL16R4-5CJ TIBPAL16R6-5CJ TIBPAL16R4-5CN TIBPAL16R6-5CN			UNIT
				MIN	TYP†	MAX	MIN	TYP†	MAX	
$f_{max}¶$	without feedback		R1 = 200 Ω , R2 = 200 Ω , See Figure 8	125			125			MHz
	with internal feedback (counter configuration)			125			125			
	with external feedback			117			111			
t_{pd}	CLK↑	Q		1.5			4.5			ns
t_{pd}	CLK↑	Internal feedback		3.5			3.5			ns
t_{pd}	I, I/O	I/O		1.5			5			ns
t_{en}	$\overline{OE}\downarrow$	Q		1.5			6			ns
t_{dis}	$\overline{OE}\uparrow$	Q		1			7			ns
t_{en}	I, I/O	I/O		2			7			ns
t_{dis}	I, I/O	I/O	2			7			ns	
t_r			1.5			1.5			ns	
t_f			1.5			1.5			ns	
$t_{sk(o)}\#$	Skew between registered outputs		0.5			0.5			ns	

† All typical values are at $V_{CC} = 5\text{ V}$, $T_A = 25^\circ\text{C}$.‡ I/O leakage is the worst case of I_{OZL} and I_{IL} or I_{OZH} and I_{IH} , respectively.§ Not more than one output should be shorted at a time, and the duration of the short circuit should not exceed one second. V_O is set at 0.5 V to avoid test problems caused by test equipment ground degradation.¶ See 'f_{max} Specification' near the end of this data sheet.# $t_{sk(o)}$ is the skew time between registered outputs.

TIBPAL16R8-5C

HIGH-PERFORMANCE *IMPACT-X*™ *PAL*® CIRCUITS

SRPS011D – D3359, OCTOBER 1989 – REVISED SEPTEMBER 1992

absolute maximum ratings over operating free-air temperature range (unless otherwise noted)

Supply voltage, V_{CC} (see Note 1)	7 V
Input voltage (see Note 1)	5.5 V
Voltage applied to disabled output (see Note 1)	5.5 V
Operating free-air temperature range	0°C to 75°C
Storage temperature range	–65°C to 150°C

NOTE 1: These ratings apply except for programming pins during a programming cycle or during a preload cycle.

recommended operating conditions

		MIN	NOM	MAX	UNIT
V_{CC}	Supply voltage	4.75	5	5.25	V
V_{IH}	High-level input voltage (see Note 2)	2		5.5	V
V_{IL}	Low-level input voltage (see Note 2)			0.8	V
I_{OH}	High-level output current			–3.2	mA
I_{OL}	Low-level output current			24	mA
f_{clock}	Clock frequency	0		125	MHz
t_w	Pulse duration, clock	High		4	ns
		Low		4	
t_{su}	Setup time, input or feedback before clock↑	4.5			ns
t_h	Hold time, input or feedback after clock↑	0			ns
T_A	Operating free-air temperature	0	25	75	°C

NOTE 2: These are absolute voltage levels with respect to the ground pin of the device and include all overshoots due to system and/or tester noise. Testing these parameters should not be attempted without suitable equipment.

electrical characteristics over recommended operating free-air temperature range

PARAMETER	TEST CONDITIONS	TIBPAL16R8-5CFN			TIBPAL16R8-5CJ TIBPAL16R8-5CN			UNIT	
		MIN	TYP†	MAX	MIN	TYP†	MAX		
V_{IK}	$V_{CC} = 4.75\text{ V}$, $I_I = -18\text{ mA}$	-0.8	-1.5		-0.8	-1.5		V	
V_{OH}	$V_{CC} = 4.75\text{ V}$, $I_{OH} = -3.2\text{ mA}$	2.4	2.7		2.4	2.7		V	
V_{OL}	$V_{CC} = 4.75\text{ V}$, $I_{OL} = 24\text{ mA}$		0.3	0.5		0.3	0.5	V	
I_{OZH}	$V_{CC} = 5.25\text{ V}$, $V_O = 2.7\text{ V}$			100			100	μA	
I_{OZL}	$V_{CC} = 5.25\text{ V}$, $V_O = 0.4\text{ V}$			-100			-100	μA	
I_I	$V_{CC} = 5.25\text{ V}$, $V_I = 5.5\text{ V}$			100			100	μA	
I_{IH}	$V_{CC} = 5.25\text{ V}$, $V_I = 2.7\text{ V}$			25			25	μA	
I_{IL}	$V_{CC} = 5.25\text{ V}$, $V_I = 0.4\text{ V}$			-250			-250	μA	
$I_{OS}‡$	$V_{CC} = 5.25\text{ V}$, $V_O = 0.5\text{ V}$	-30	-70	-130	-30	-70	-130	mA	
I_{CC}	$V_{CC} = 5.25\text{ V}$, $V_I = 0$, Outputs open			180			180	mA	
C_i	I CLK/OE	$f = 1\text{ MHz}$, $V_I = 2\text{ V}$	8.5			6.5			pF
			7.5			5.5			
C_o	$f = 1\text{ MHz}$, $V_O = 2\text{ V}$	10			8			pF	

switching characteristics over recommended ranges of supply voltage and operating free-air temperature (unless otherwise noted)

PARAMETER	FROM (INPUT)	TO (OUTPUT)	TEST CONDITIONS	TIBPAL16R8-5CFN			TIBPAL16R8-5CJ TIBPAL16R8-5CN			UNIT	
				MIN	TYP†	MAX	MIN	TYP†	MAX		
$f_{max}§$	without feedback		R1 = 200 Ω , R2 = 200 Ω , See Figure 8	125			125			MHz	
	with internal feedback (counter configuration)			125			125				
	with external feedback			117			111				
t_{pd}	CLK↑	Q		with up to 4 outputs switching	1.5	4	1.5	4	ns		
	CLK↑	Q		with more than 4 outputs switching	1.5	4	1.5	4.5			
$t_{pd}¶$	CLK↑	Internal feedback		3.5			3.5			ns	
t_{en}	$\overline{OE}\downarrow$	Q		1.5	6	1.5	6	ns			
t_{dis}	$\overline{OE}\uparrow$	Q		1	6.5	1	7	ns			
t_r				1.5			1.5			ns	
t_f				1.5			1.5			ns	
$t_{sk(o)}\#$	Skew between outputs			0.5			0.5			ns	

† All typical values are at $V_{CC} = 5\text{ V}$, $T_A = 25^\circ\text{C}$.

‡ Not more than one output should be shorted at a time, and the duration of the short circuit should not exceed one second. V_O is set at 0.5 V to avoid test problems caused by test equipment ground degradation.

§ See 'f_{max} Specification' near the end of this data sheet.

¶ This parameter is calculated from the measured f_{max} with internal feedback in a counter configuration (see Figure 2 for illustration).

t_{sk(o)} is the skew time between registered outputs.

TIBPAL16L8-7M, TIBPAL16R4-7M, TIBPAL16R6-7M, TIBPAL16R8-7M HIGH-PERFORMANCE *IMPACT-X*[™] *PAL*[®] CIRCUITS

SRPS011D – D3359, OCTOBER 1989 – REVISED SEPTEMBER 1992

absolute maximum ratings over operating free-air temperature range (unless otherwise noted)

Supply voltage, V_{CC} (see Note 1)	7 V
Input voltage (see Note 1)	5.5 V
Voltage applied to disabled output (see Note 1)	5.5 V
Operating free-air temperature range	–55°C to 125°C
Storage temperature range	–65°C to 150°C

NOTE 1: These ratings apply except for programming pins during a programming cycle or during a preload cycle.

recommended operating conditions

		MIN	NOM	MAX	UNIT
V_{CC}	Supply voltage	4.5	5	5.5	V
V_{IH}	High-level input voltage (see Note 2)	2		5.5	V
V_{IL}	Low-level input voltage (see Note 2)			0.8	V
I_{OH}	High-level output current			–2	mA
I_{OL}	Low-level output current			12	mA
f_{clock}^{\dagger}	Clock frequency	0		100	MHz
t_w^{\dagger}	Pulse duration, clock	High		5	ns
		Low		5	
t_{su}^{\dagger}	Setup time, input or feedback before clock \uparrow	7			ns
t_h^{\dagger}	Hold time, input or feedback after clock \uparrow	0			ns
T_A	Operating free-air temperature	–55	25	125	°C

 $\dagger f_{clock}$, t_w , t_{su} , and t_h do not apply to TIBPAL16L8'

NOTE 2: These are absolute voltage levels with respect to the ground pin of the device and include all overshoots due to system and/or tester noise. Testing these parameters should not be attempted without suitable equipment.

PRODUCT PREVIEW

TIBPAL16L8-7M, TIBPAL16R4-7M, TIBPAL16R6-7M, TIBPAL16R8-7M
HIGH-PERFORMANCE *IMPACT-X*™ PAL® CIRCUITS

SRPS011D – D3359, OCTOBER 1989 – REVISED SEPTEMBER 1992

electrical characteristics over recommended operating free-air temperature range

PARAMETER		TEST CONDITIONS		MIN	TYP†	MAX	UNIT
V _{IK}		V _{CC} = 4.5 V,	I _I = –18 mA		–0.8	–1.5	V
V _{OH}		V _{CC} = 4.5 V,	I _{OH} = –2 mA	2.4	2.7		V
V _{OL}		V _{CC} = 4.5 V,	I _{OL} = 12 mA		0.25	0.5	V
I _{OZH}	0, Q outputs	V _{CC} = 5.5 V,	V _O = 2.7 V			20	μA
	I/O ports					100	
I _{OZL}	0, Q outputs	V _{CC} = 5.5 V,	V _O = 0.4 V			–20	μA
	I/O ports					–250	
I _I		V _{CC} = 5.5 V,	V _I = 5.5 V			1	mA
I _{IH}	I/O ports	V _{CC} = 5.5 V,	V _I = 2.7 V			100	μA
	All others					25	
I _{IL}		V _{CC} = 5.5 V,	V _I = 0.4 V			–250	μA
I _{OS‡}		V _{CC} = 5.5 V,	V _O = 0.5 V	–30	–70	–130	mA
I _{CC}		V _{CC} = 5.5 V,	V _I = GND, $\overline{OE} = V_{IH}$, Outputs open			210	mA
C _i	I	f = 1 MHz,	V _I = 2 V			8.5	pF
	CLK/ \overline{OE}					7.5	
C _o		f = 1 MHz,	V _O = 2 V			10	pF

† All typical values are at V_{CC} = 5 V, T_A = 25°C.‡ Not more than one output should be shorted at a time, and the duration of the short circuit should not exceed one second. V_O is set at 0.5 V to avoid test problems caused by test equipment ground degradation.
switching characteristics over recommended ranges of supply voltage and operating free-air temperature (unless otherwise noted)

PARAMETER	FROM (INPUT)	TO (OUTPUT)	TEST CONDITION	MIN	MAX	UNIT
f _{max} §	without feedback		R1 = 390 Ω, R2 = 750 Ω, See Figure 8	100		MHz
	with internal feedback (counter configuration)			100		
	with external feedback			74		
t _{pd}	I, I/O	O, I/O		1	7	ns
t _{pd}	CLK	Q		1	7	ns
t _{en}	OE↓	Q		1	8	ns
t _{dis}	OE↑	Q	1	10	ns	
t _{en}	I, I/O	O, I/O	1	9	ns	
t _{dis}	I, I/O	O, I/O	1	10	ns	

§ See 'f_{max} Specification' near the end of this data sheet. f_{max} does not apply for TIBPAL16L8'. f_{max} with external feedback is not production tested and is calculated from the equation located in the f_{max} specifications section.
PRODUCT PREVIEW

TIBPAL16L8-5C, TIBPAL16R4-5C, TIBPAL16R6-5C, TIBPAL16R8-5C
 TIBPAL16L8-7M, TIBPAL16R4-7M, TIBPAL16R6-7M, TIBPAL16R8-7M
 HIGH-PERFORMANCE *IMPACT-X*[™] PAL[®] CIRCUITS

SRPS011D – D3359, OCTOBER 1989 – REVISED SEPTEMBER 1992

programming information

Texas Instruments programmable logic devices can be programmed using widely available software and inexpensive device programmers.

Complete programming specifications, algorithms, and the latest information on hardware, software, and firmware are available upon request. Information on programmers capable of programming Texas Instruments programmable logic is also available, upon request, from the nearest TI field sales office, local authorized TI distributor, or by calling Texas Instruments at (214) 997-5666.

asynchronous preload procedure for registered outputs (see Figure 1 and Note 3)[†]

The output registers can be preloaded to any desired state during device testing. This permits any state to be tested without having to step through the entire state-machine sequence. Each register is preloaded individually by following the steps given below.

- Step 1. With V_{CC} at 5 volts and Pin 1 at V_{IL} , raise Pin 11 to V_{IHH} .
- Step 2. Apply either V_{IL} or V_{IH} to the output corresponding to the register to be preloaded.
- Step 3. Lower Pin 11 to 5 V.
- Step 4. Remove output voltage, then lower Pin 11 to V_{IL} . Preload can be verified by observing the voltage level at the output pin.

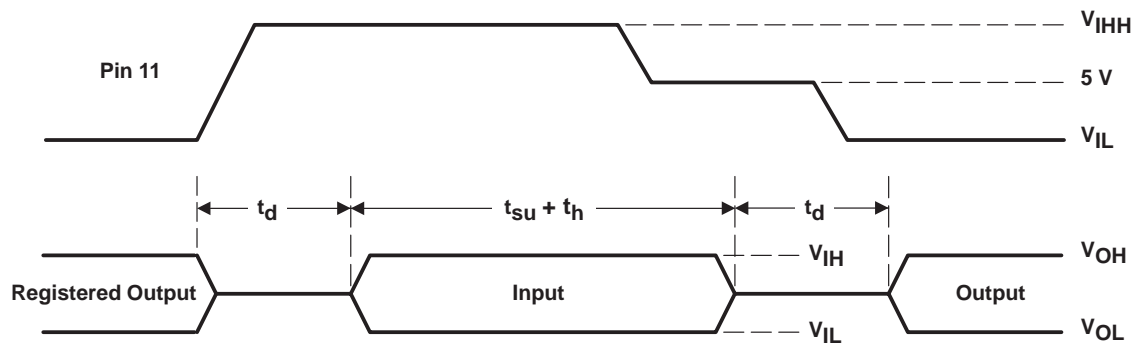

Figure 1. Asynchronous Preload Waveforms [†]

[†] Not applicable for TIBPAL16L8-5C and TIBPAL16L8-7M.

NOTE 3: $t_d = t_{su} = t_h = 100$ ns to 1000 ns

$V_{IHH} = 10.25$ V to 10.75 V

power-up reset (see Figure 2)

Following power up, all registers are reset to zero. This feature provides extra flexibility to the system designer and is especially valuable in simplifying state-machine initialization. To ensure a valid power-up reset, it is important that the rise of V_{CC} be monotonic. Following power-up reset, a low-to-high clock transition must not occur until all applicable input and feedback setup times are met.

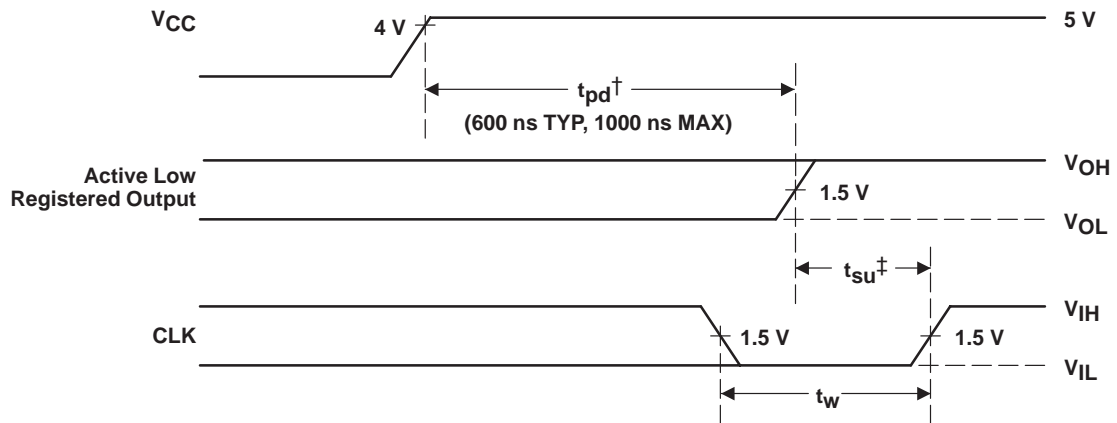

[†] This is the power-up reset time and applies to registered outputs only. The values shown are from characterization data.

[‡] This is the setup time for input or feedback.

Figure 2. Power-Up Reset Waveforms

TIBPAL16R4-5C, TIBPAL16R6-5C, TIBPAL16R8-5C
 TIBPAL16R4-7M, TIBPAL16R6-7M, TIBPAL16R8-7M
 HIGH-PERFORMANCE *IMPACT-X*™ PAL® CIRCUITS
 SRPS011D – D3359, OCTOBER 1989 – REVISED SEPTEMBER 1992

f_{\max} SPECIFICATIONS

f_{\max} without feedback (see Figure 3)

In this mode, data is presented at the input to the flip-flop and clocked through to the Q output with no feedback. Under this condition, the clock period is limited by the sum of the data setup time and the data hold time ($t_{su} + t_h$). However, the minimum f_{\max} is determined by the minimum clock period ($t_{w\text{ high}} + t_{w\text{ low}}$).

$$\text{Thus, } f_{\max} \text{ without feedback} = \frac{1}{(t_{w\text{ high}} + t_{w\text{ low}})} \text{ or } \frac{1}{(t_{su} + t_h)}$$

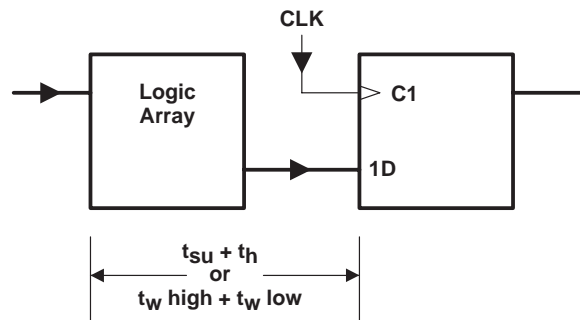

Figure 3. f_{\max} Without Feedback

f_{\max} with internal feedback (see Figure 4)

This configuration is most popular in counters and on-chip state-machine designs. The flip-flop inputs are defined by the device inputs and flip-flop outputs. Under this condition, the period is limited by the internal delay from the flip-flop outputs through the internal feedback and logic array to the inputs of the next flip-flop.

$$\text{Thus, } f_{\max} \text{ with internal feedback} = \frac{1}{(t_{su} + t_{pd\text{ CLK-to-FB}})}$$

Where $t_{pd\text{ CLK-to-FB}}$ is the deduced value of the delay from CLK to the input of the logic array.

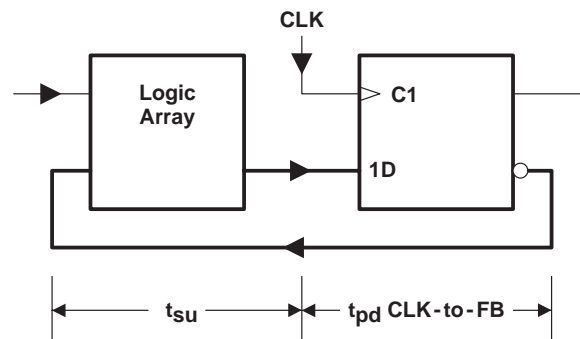

Figure 4. f_{\max} With Internal Feedback

f_{\max} SPECIFICATIONS

f_{\max} with external feedback (see Figure 5)

This configuration is a typical state-machine design with feedback signals sent off-chip. This external feedback could go back to the device inputs or to a second device in a multi-chip state machine. The slowest path defining the period is the sum of the clock-to-output time and the input setup time for the external signals ($t_{\text{su}} + t_{\text{pd CLK-to-Q}}$).

Thus, f_{\max} with external feedback = $\frac{1}{(t_{\text{su}} + t_{\text{pd CLK-to-Q}})}$

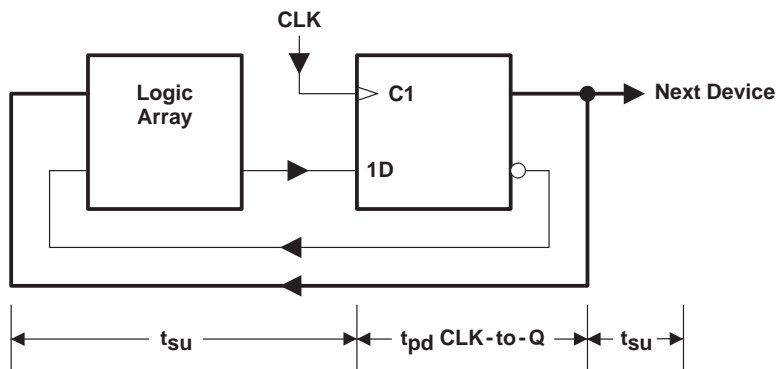

Figure 5. f_{\max} With External Feedback

TIBPAL16R8-5C
HIGH-PERFORMANCE *IMPACT-X*™ *PAL*® CIRCUITS

SRPS011D – D3359, OCTOBER 1989 – REVISED SEPTEMBER 1992

THERMAL INFORMATION

thermal management of the TIBPAL16R8-5C

Thermal management of the TIBPAL16R8-5CN and TIBPAL16R8-5CFN is necessary when operating at certain conditions of frequency, output loading, and outputs switching simultaneously. The device and system application will determine the appropriate level of management.

Determining the level of thermal management is based on factors such as power dissipation (P_D), ambient temperature (T_A), and transverse airflow (FPM). Figures 6 (a) and 6 (b) show the relationship between ambient temperature and transverse airflow at given power dissipation levels. The required transverse airflow can be determined at a particular ambient temperature and device power dissipation level in order to ensure the device specifications.

Figure 7 illustrates how power dissipation varies as a function of frequency and the number of outputs switching simultaneously. It should be noted that all outputs are fully loaded ($C_L = 50$ pF). Since the condition of eight fully loaded outputs represents the worst-case condition, each application must be evaluated accordingly.

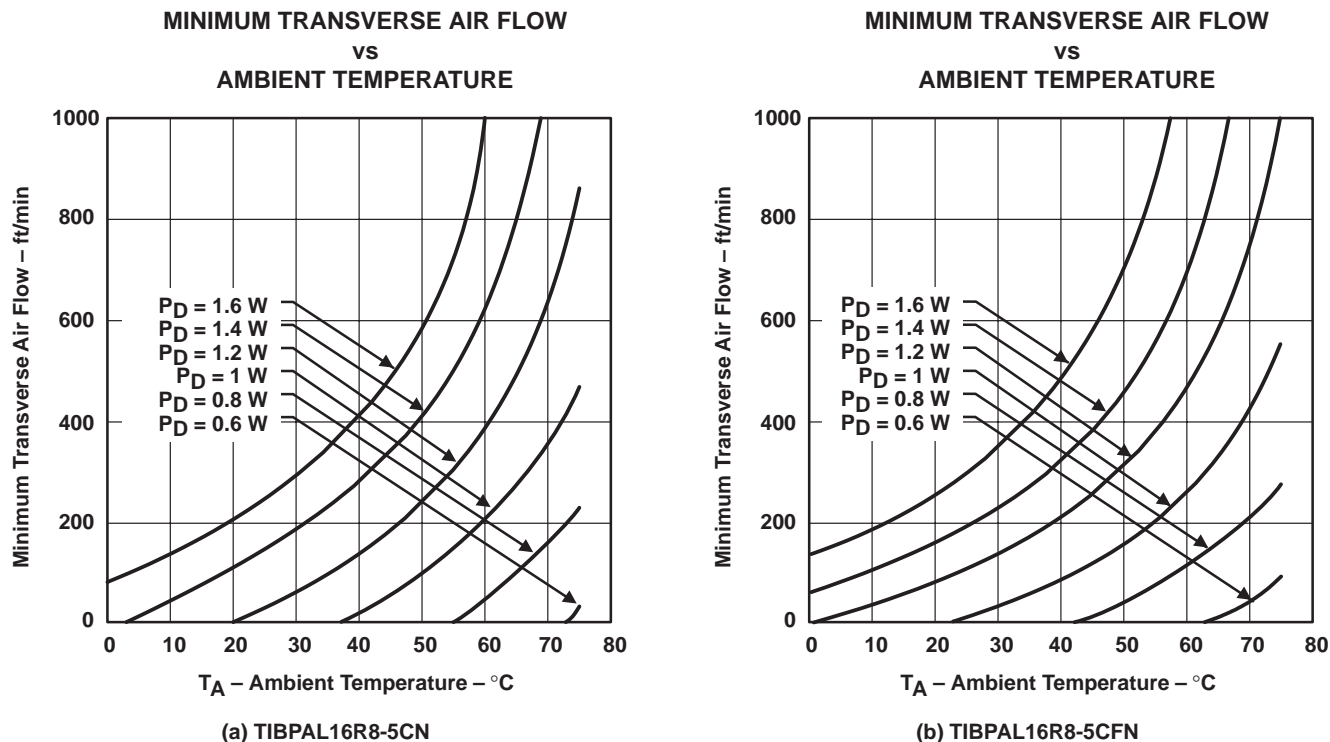

Figure 6

THERMAL INFORMATION

POWER DISSIPATION
vs
FREQUENCY

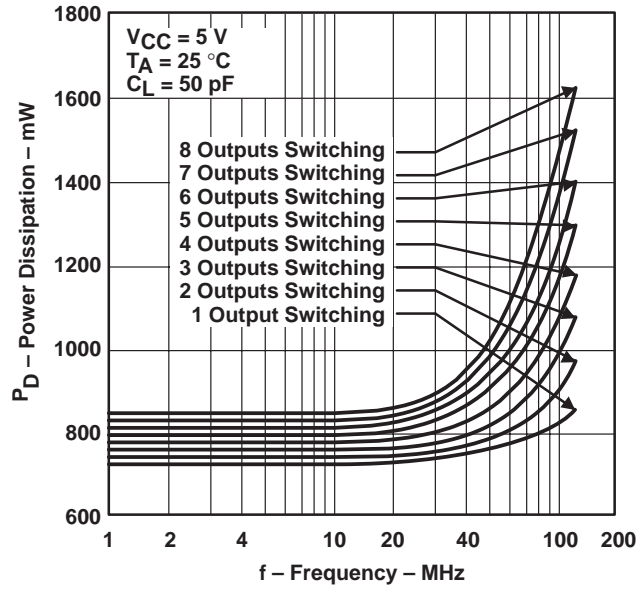
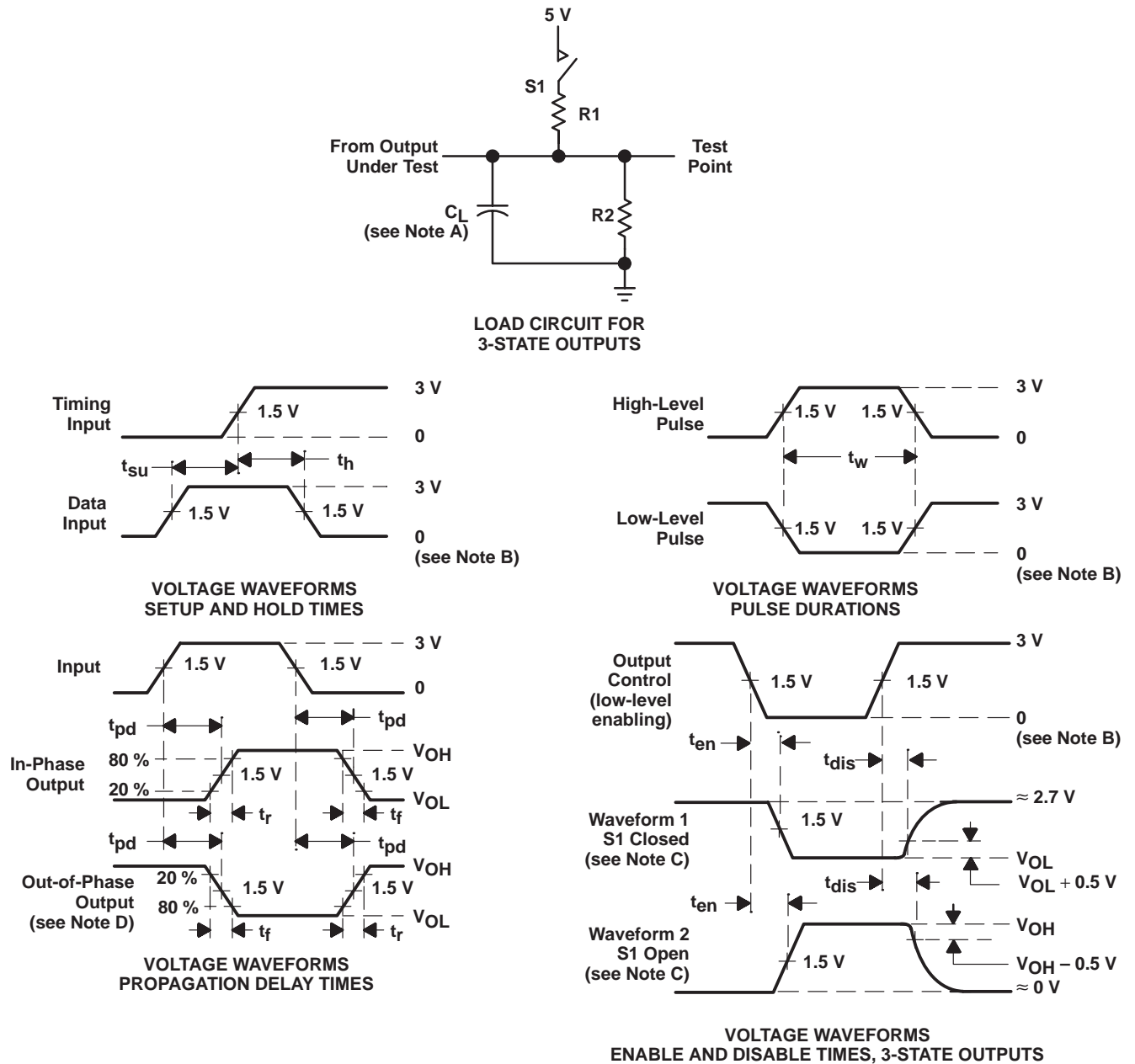

Figure 7

TIBPAL16L8-5C, TIBPAL16R4-5C, TIBPAL16R6-5C, TIBPAL16R8-5C
 TIBPAL16L8-7M, TIBPAL16R4-7M, TIBPAL16R6-7M, TIBPAL16R8-7M
 HIGH-PERFORMANCE *IMPACT-X*[™] PAL[®] CIRCUITS

SRPS011D - D3359, OCTOBER 1989 - REVISED SEPTEMBER 1992

PARAMETER MEASUREMENT INFORMATION



- NOTES: A. C_L includes probe and jig capacitance and is 50 pF for t_{pd} and t_{en} , 5 pF for t_{dis} .
 B. All input pulses have the following characteristics: For C suffix, PRR ≤ 1 MHz, $t_r = t_f = 2$ ns, duty cycle = 50%; For M suffix, PRR ≤ 10 MHz, $t_r = t_f ≤ 2$ ns, duty cycle = 50%.
 C. Waveform 1 is for an output with internal conditions such that the output is low except when disabled by the output control. Waveform 2 is for an output with internal conditions such that the output is high except when disabled by the output control.
 D. When measuring propagation delay times of 3-state outputs, switch S1 is closed.
 E. Equivalent loads may be used for testing.

Figure 8. Load Circuit and Voltage Waveforms

metastable characteristics of TIBPAL16R4-5C, TIBPAL16R6-5C, and TIBPAL16R8-5C

At some point a system designer is faced with the problem of synchronizing two digital signals operating at two different frequencies. This problem is typically overcome by synchronizing one of the signals to the local clock through use of a flip-flop. However, this solution presents an awkward dilemma since the setup and hold time specifications associated with the flip-flop are sure to be violated. The metastable characteristics of the flip-flop can influence overall system reliability.

Whenever the setup and hold times of a flip-flop are violated, its output response becomes uncertain and is said to be in the metastable state if the output hangs up in the region between V_{IL} and V_{IH} . This metastable condition lasts until the flip-flop falls into one of its two stable states, which takes longer than the specified maximum propagation delay time (CLK to Q max).

From a system engineering standpoint, a designer cannot use the specified data sheet maximum for propagation delay time when using the flip-flop as a data synchronizer – how long to wait after the specified data sheet maximum must be known before using the data in order to guarantee reliable system operation.

The circuit shown in Figure 9 can be used to evaluate MTBF (Mean Time Between Failure) and Δt for a selected flip-flop. Whenever the Q output of the DUT is between 0.8 V and 2 V, the comparators are in opposite states. When the Q output of the DUT is higher than 2 V or lower than 0.8 V, the comparators are at the same logic level. The outputs of the two comparators are sampled a selected time (Δt) after system clock (SCLK). The exclusive OR gate detects the occurrence of a failure and increments the failure counter.

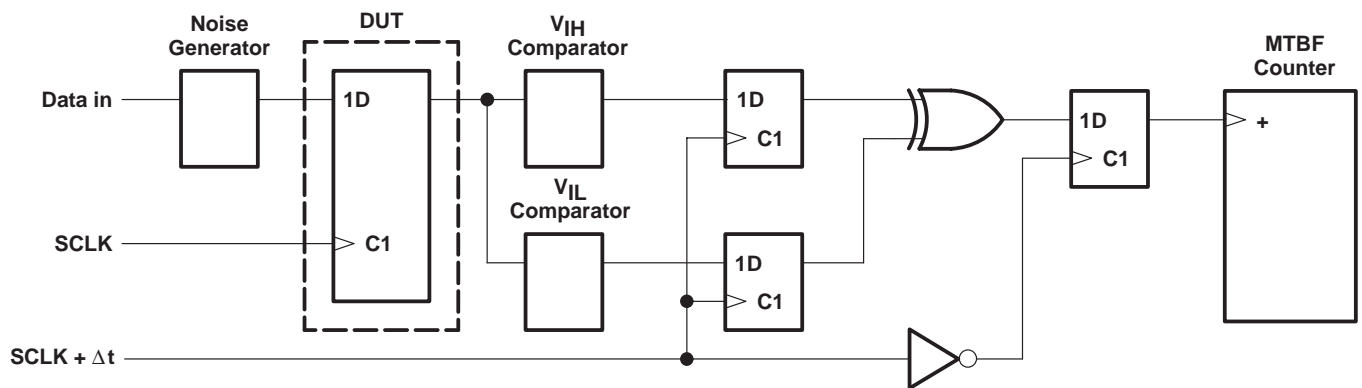

Figure 9. Metastable Evaluation Test Circuit

In order to maximize the possibility of forcing the DUT into a metastable state, the input data signal is applied so that it always violates the setup and hold time. This condition is illustrated in the timing diagram in Figure 10. Any other relationship of SCLK to data will provide less chance for the device to enter into the metastable state.

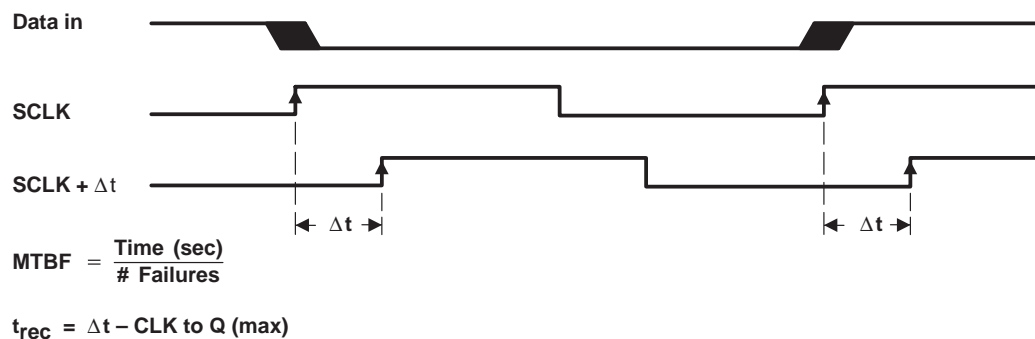

Figure 10. Timing Diagram

TIBPAL16R4-5C, TIBPAL16R6-5C, TIBPAL16R8-5C HIGH-PERFORMANCE *IMPACT-X*™ *PAL*® CIRCUITS

SRPS011D – D3359, OCTOBER 1989 – REVISED SEPTEMBER 1992

By using the described test circuit, MTBF can be determined for several different values of Δt (see Figure 9). Plotting this information on semilog scale demonstrates the metastable characteristics of the selected flip-flop. Figure 11 shows the results for the TIBPAL16'-5C operating at 1 MHz.

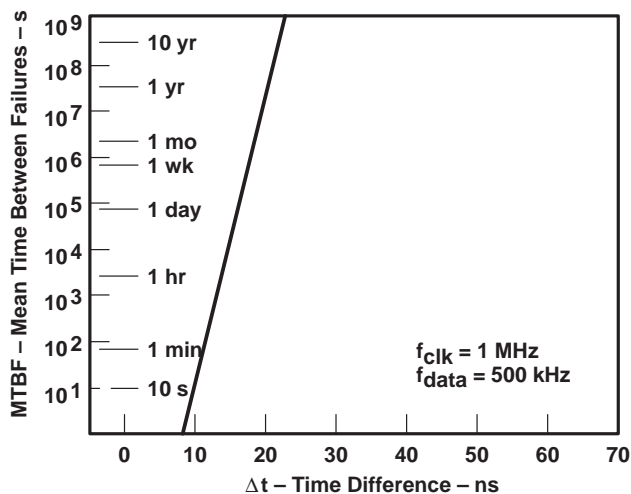

Figure 11. Metastable Characteristics

From the data taken in the above experiment, an equation can be derived for the metastable characteristics at other clock frequencies.

The metastable equation: $\frac{1}{\text{MTBF}} = f_{\text{SCLK}} \times f_{\text{data}} \times C1 \times e^{-C2 \times \Delta t}$

The constants C1 and C2 describe the metastable characteristics of the device. From the experimental data, these constants can be solved for: $C1 = 4.37 \times 10^{-3}$ and $C2 = 2.01$

Therefore

$$\frac{1}{\text{MTBF}} = f_{\text{SCLK}} \times f_{\text{data}} \times 4.37 \times 10^{-3} \times e^{-2.01 \times \Delta t}$$

definition of variables

DUT (Device Under Test): The DUT is a 5-ns registered PLD programmed with the equation $Q = D$.

MTBF (Mean Time Between Failures): The average time (s) between metastable occurrences that cause a violation of the device specifications.

f_{SCLK} (system clock frequency): Actual clock frequency for the DUT.

f_{data} (data frequency): Actual data frequency for a specified input to the DUT.

C1: Calculated constant that defines the magnitude of the curve.

C2: Calculated constant that defines the slope of the curve.

t_{rec} (metastability recovery time): Minimum time required to guarantee recovery from metastability, at a given MTBF failure rate. $t_{\text{rec}} = \Delta t - t_{\text{pd}}$ (CLK to Q, max)

Δt : The time difference (ns) from when the synchronizing flip-flop is clocked to when its output is sampled.

The test described above has shown the metastable characteristics of the TIBPAL16R4/R6/R8-5C series. For additional information on metastable characteristics of Texas Instruments logic circuits, please refer to TI Applications publication SDAA004, "Metastable Characteristics, Design Considerations for ALS, AS, and LS Circuits."

TYPICAL CHARACTERISTICS

LOW-LEVEL OUTPUT CURRENT
 vs
 LOW-LEVEL OUTPUT VOLTAGE

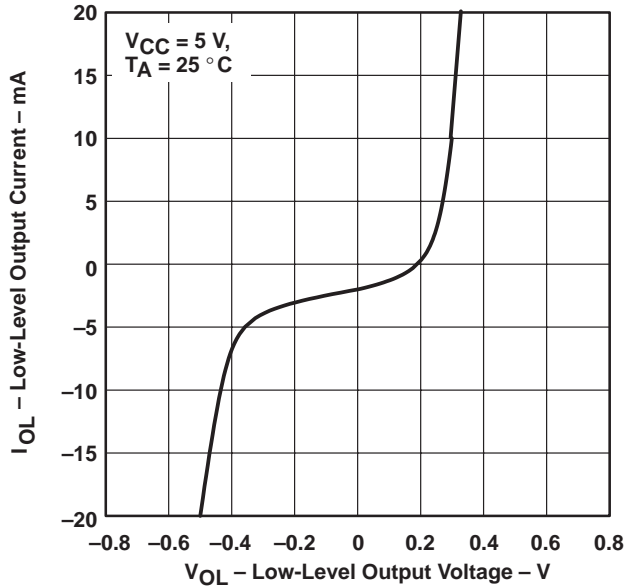

Figure 12

HIGH-LEVEL OUTPUT CURRENT
 vs
 HIGH-LEVEL OUTPUT VOLTAGE

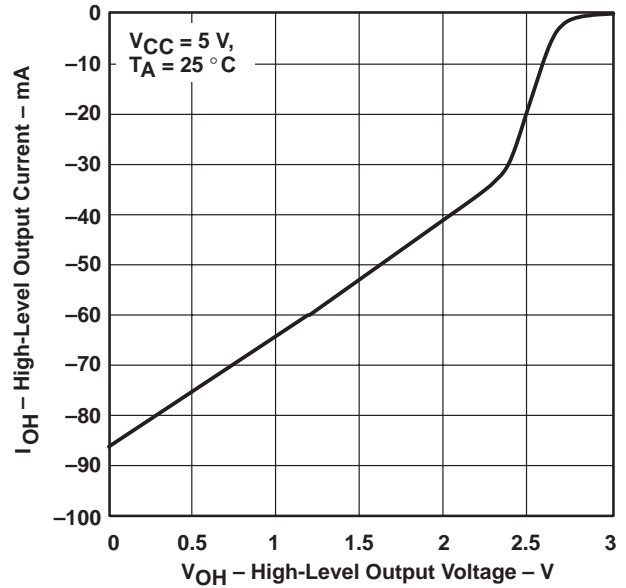

Figure 13

SUPPLY CURRENT
 vs
 FREE-AIR TEMPERATURE

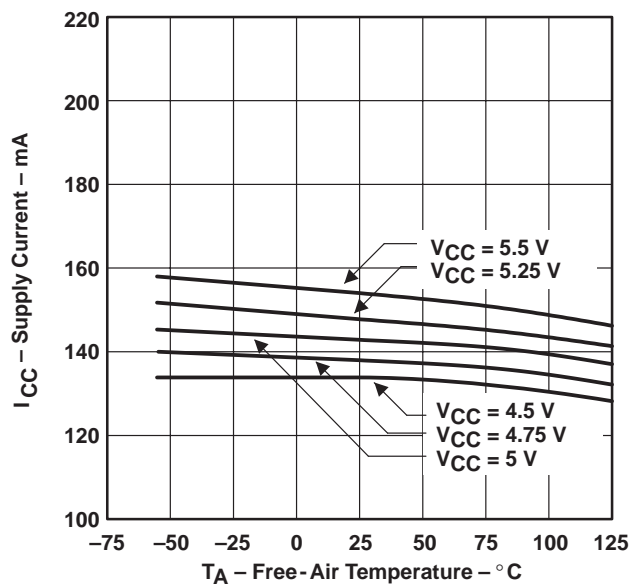

Figure 14

TIBPAL16L8-5C, TIBPAL16R4-5C, TIBPAL16R6-5C, TIBPAL16R8-5C
 TIBPAL16L8-7M, TIBPAL16R4-7M, TIBPAL16R6-7M, TIBPAL16R8-7M
 HIGH-PERFORMANCE *IMPACT-X*™ PAL® CIRCUITS

SRPS011D - D3359, OCTOBER 1989 - REVISED SEPTEMBER 1992

TYPICAL CHARACTERISTICS

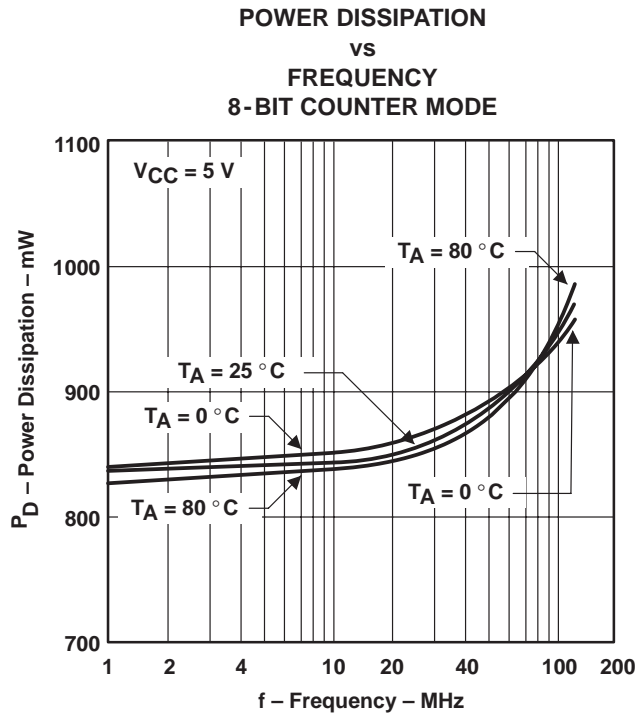

Figure 15

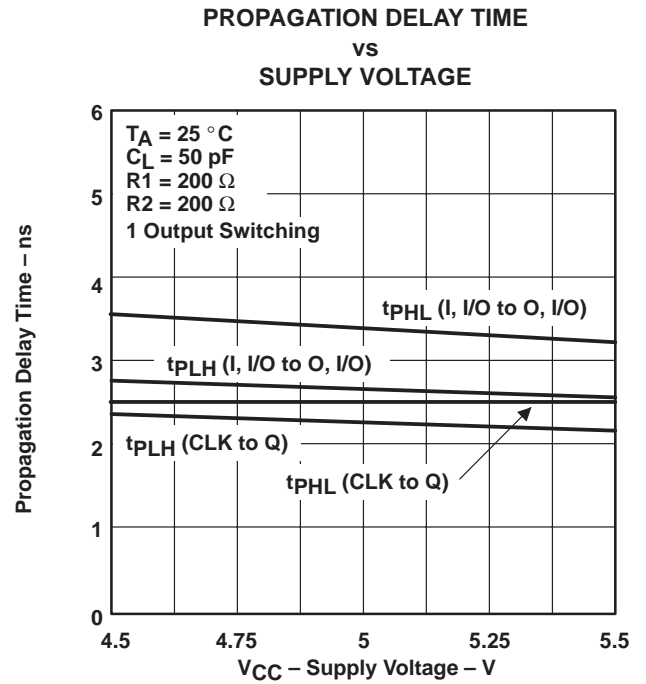

Figure 16

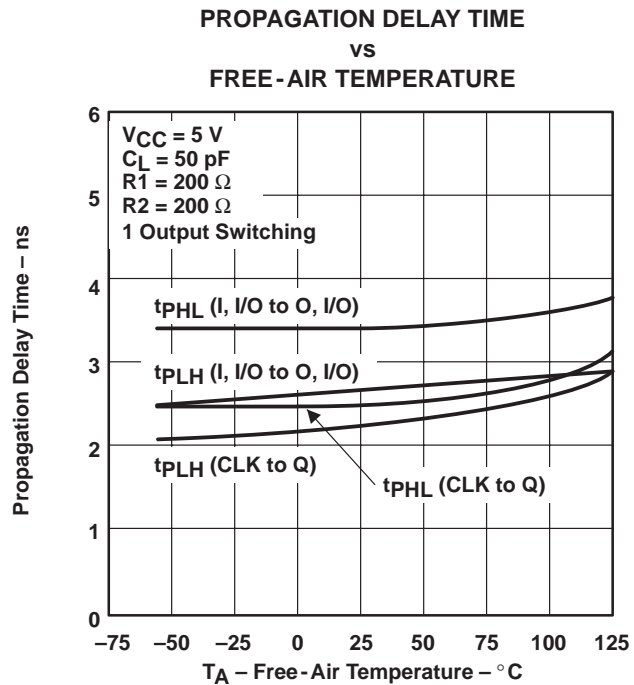

Figure 17

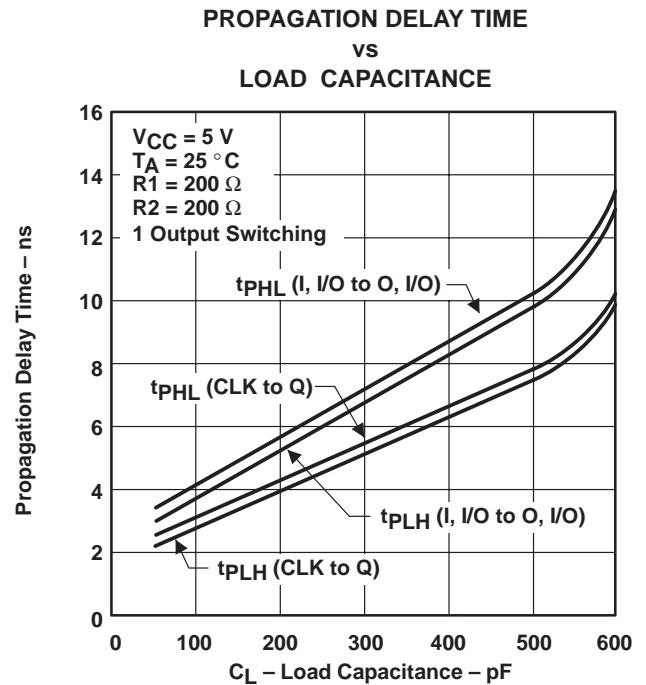

Figure 18

TYPICAL CHARACTERISTICS

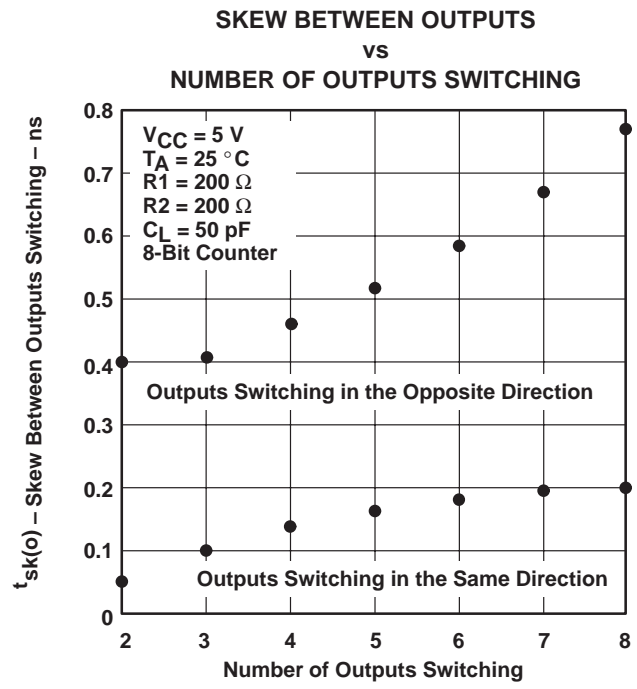

Figure 19

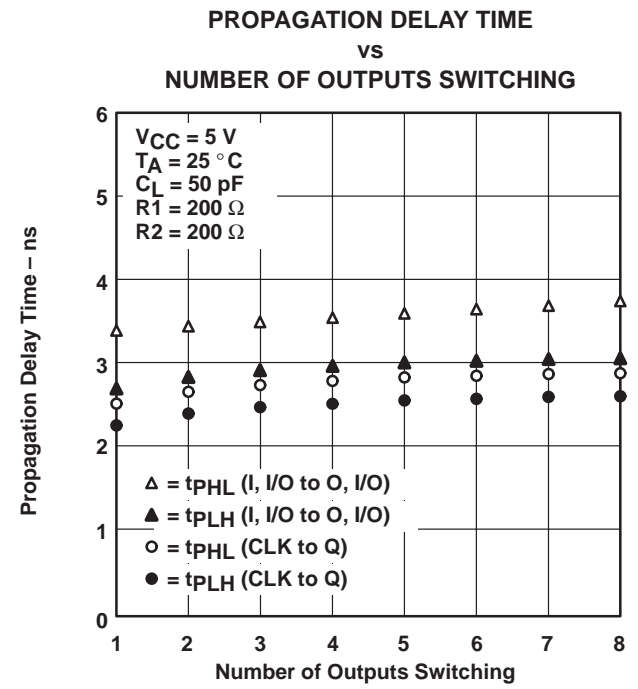

Figure 20

PACKAGING INFORMATION

Orderable Device	Status (1)	Package Type	Package Drawing	Pins	Package Qty	Eco Plan (2)	Lead/Ball Finish (6)	MSL Peak Temp (3)	Op Temp (°C)	Device Marking (4/5)	Samples
5962-85155212A	NRND	LCCC	FK	20	1	TBD	POST-PLATE	N / A for Pkg Type	-55 to 125	5962- 85155212A TIBPAL16 R8-7MFKB	
5962-8515521RA	NRND	CDIP	J	20	1	TBD	A42	N / A for Pkg Type	-55 to 125	5962-8515521RA TIBPAL16R8-7MJ B	
5962-8515521SA	NRND	CFP	W	20	1	TBD	A42	N / A for Pkg Type	-55 to 125	5962-8515521SA TIBPAL16R8-7MW B	
TIBPAL16L8-5CFN	OBSOLETE	PLCC	FN	20		TBD	Call TI	Call TI	0 to 70		
TIBPAL16L8-5CN	OBSOLETE	PDIP	N	20		TBD	Call TI	Call TI	0 to 75		
TIBPAL16R4-5CN	OBSOLETE	PDIP	N	20		TBD	Call TI	Call TI	0 to 75		
TIBPAL16R6-5CFN	OBSOLETE	PLCC	FN	20		TBD	Call TI	Call TI	0 to 75	16R6-5	
TIBPAL16R6-5CN	OBSOLETE	PDIP	N	20		TBD	Call TI	Call TI	0 to 75	TIBPAL16R6-5CN	
TIBPAL16R8-7MFKB	NRND	LCCC	FK	20	1	TBD	POST-PLATE	N / A for Pkg Type	-55 to 125	5962- 85155212A TIBPAL16 R8-7MFKB	
TIBPAL16R8-7MJB	NRND	CDIP	J	20	1	TBD	A42	N / A for Pkg Type	-55 to 125	5962-8515521RA TIBPAL16R8-7MJ B	
TIBPAL16R8-7MWB	NRND	CFP	W	20	1	TBD	A42	N / A for Pkg Type	-55 to 125	5962-8515521SA TIBPAL16R8-7MW B	

(1) The marketing status values are defined as follows:

ACTIVE: Product device recommended for new designs.

LIFEBUY: TI has announced that the device will be discontinued, and a lifetime-buy period is in effect.

NRND: Not recommended for new designs. Device is in production to support existing customers, but TI does not recommend using this part in a new design.

PREVIEW: Device has been announced but is not in production. Samples may or may not be available.

OBSOLETE: TI has discontinued the production of the device.

(2) Eco Plan - The planned eco-friendly classification: Pb-Free (RoHS), Pb-Free (RoHS Exempt), or Green (RoHS & no Sb/Br) - please check <http://www.ti.com/productcontent> for the latest availability information and additional product content details.

TBD: The Pb-Free/Green conversion plan has not been defined.

Pb-Free (RoHS): TI's terms "Lead-Free" or "Pb-Free" mean semiconductor products that are compatible with the current RoHS requirements for all 6 substances, including the requirement that lead not exceed 0.1% by weight in homogeneous materials. Where designed to be soldered at high temperatures, TI Pb-Free products are suitable for use in specified lead-free processes.

Pb-Free (RoHS Exempt): This component has a RoHS exemption for either 1) lead-based flip-chip solder bumps used between the die and package, or 2) lead-based die adhesive used between the die and leadframe. The component is otherwise considered Pb-Free (RoHS compatible) as defined above.

Green (RoHS & no Sb/Br): TI defines "Green" to mean Pb-Free (RoHS compatible), and free of Bromine (Br) and Antimony (Sb) based flame retardants (Br or Sb do not exceed 0.1% by weight in homogeneous material)

⁽³⁾ MSL, Peak Temp. - The Moisture Sensitivity Level rating according to the JEDEC industry standard classifications, and peak solder temperature.

⁽⁴⁾ There may be additional marking, which relates to the logo, the lot trace code information, or the environmental category on the device.

⁽⁵⁾ Multiple Device Markings will be inside parentheses. Only one Device Marking contained in parentheses and separated by a "~" will appear on a device. If a line is indented then it is a continuation of the previous line and the two combined represent the entire Device Marking for that device.

⁽⁶⁾ Lead/Ball Finish - Orderable Devices may have multiple material finish options. Finish options are separated by a vertical ruled line. Lead/Ball Finish values may wrap to two lines if the finish value exceeds the maximum column width.

Important Information and Disclaimer:The information provided on this page represents TI's knowledge and belief as of the date that it is provided. TI bases its knowledge and belief on information provided by third parties, and makes no representation or warranty as to the accuracy of such information. Efforts are underway to better integrate information from third parties. TI has taken and continues to take reasonable steps to provide representative and accurate information but may not have conducted destructive testing or chemical analysis on incoming materials and chemicals. TI and TI suppliers consider certain information to be proprietary, and thus CAS numbers and other limited information may not be available for release.

In no event shall TI's liability arising out of such information exceed the total purchase price of the TI part(s) at issue in this document sold by TI to Customer on an annual basis.

J (R-GDIP-T**)

14 LEADS SHOWN

CERAMIC DUAL IN-LINE PACKAGE



DIM \ PINS **	14	16	18	20
A	0.300 (7,62) BSC	0.300 (7,62) BSC	0.300 (7,62) BSC	0.300 (7,62) BSC
B MAX	0.785 (19,94)	.840 (21,34)	0.960 (24,38)	1.060 (26,92)
B MIN	—	—	—	—
C MAX	0.300 (7,62)	0.300 (7,62)	0.310 (7,87)	0.300 (7,62)
C MIN	0.245 (6,22)	0.245 (6,22)	0.220 (5,59)	0.245 (6,22)



4040083/F 03/03

- NOTES:
- All linear dimensions are in inches (millimeters).
 - This drawing is subject to change without notice.
 - This package is hermetically sealed with a ceramic lid using glass frit.
 - Index point is provided on cap for terminal identification only on press ceramic glass frit seal only.
 - Falls within MIL STD 1835 GDIP1-T14, GDIP1-T16, GDIP1-T18 and GDIP1-T20.

W (R-GDFP-F20)

CERAMIC DUAL FLATPACK



- NOTES:
- A. All linear dimensions are in inches (millimeters).
 - B. This drawing is subject to change without notice.
 - C. This package can be hermetically sealed with a ceramic lid using glass frit.
 - D. Index point is provided on cap for terminal identification only.
 - E. Falls within Mil-Std 1835 GDFP2-F20

FK (S-CQCC-N**)

LEADLESS CERAMIC CHIP CARRIER

28 TERMINAL SHOWN



NO. OF TERMINALS **	A		B	
	MIN	MAX	MIN	MAX
20	0.342 (8,69)	0.358 (9,09)	0.307 (7,80)	0.358 (9,09)
28	0.442 (11,23)	0.458 (11,63)	0.406 (10,31)	0.458 (11,63)
44	0.640 (16,26)	0.660 (16,76)	0.495 (12,58)	0.560 (14,22)
52	0.740 (18,78)	0.761 (19,32)	0.495 (12,58)	0.560 (14,22)
68	0.938 (23,83)	0.962 (24,43)	0.850 (21,6)	0.858 (21,8)
84	1.141 (28,99)	1.165 (29,59)	1.047 (26,6)	1.063 (27,0)



4040140/D 01/11

- NOTES:
- All linear dimensions are in inches (millimeters).
 - This drawing is subject to change without notice.
 - This package can be hermetically sealed with a metal lid.
 - Falls within JEDEC MS-004

N (R-PDIP-T**)

PLASTIC DUAL-IN-LINE PACKAGE

16 PINS SHOWN



- NOTES:
- A. All linear dimensions are in inches (millimeters).
 - B. This drawing is subject to change without notice.
 - C Falls within JEDEC MS-001, except 18 and 20 pin minimum body length (Dim A).
 - D The 20 pin end lead shoulder width is a vendor option, either half or full width.

FN (S-PQCC-J**)

PLASTIC J-LEADED CHIP CARRIER

20 PIN SHOWN

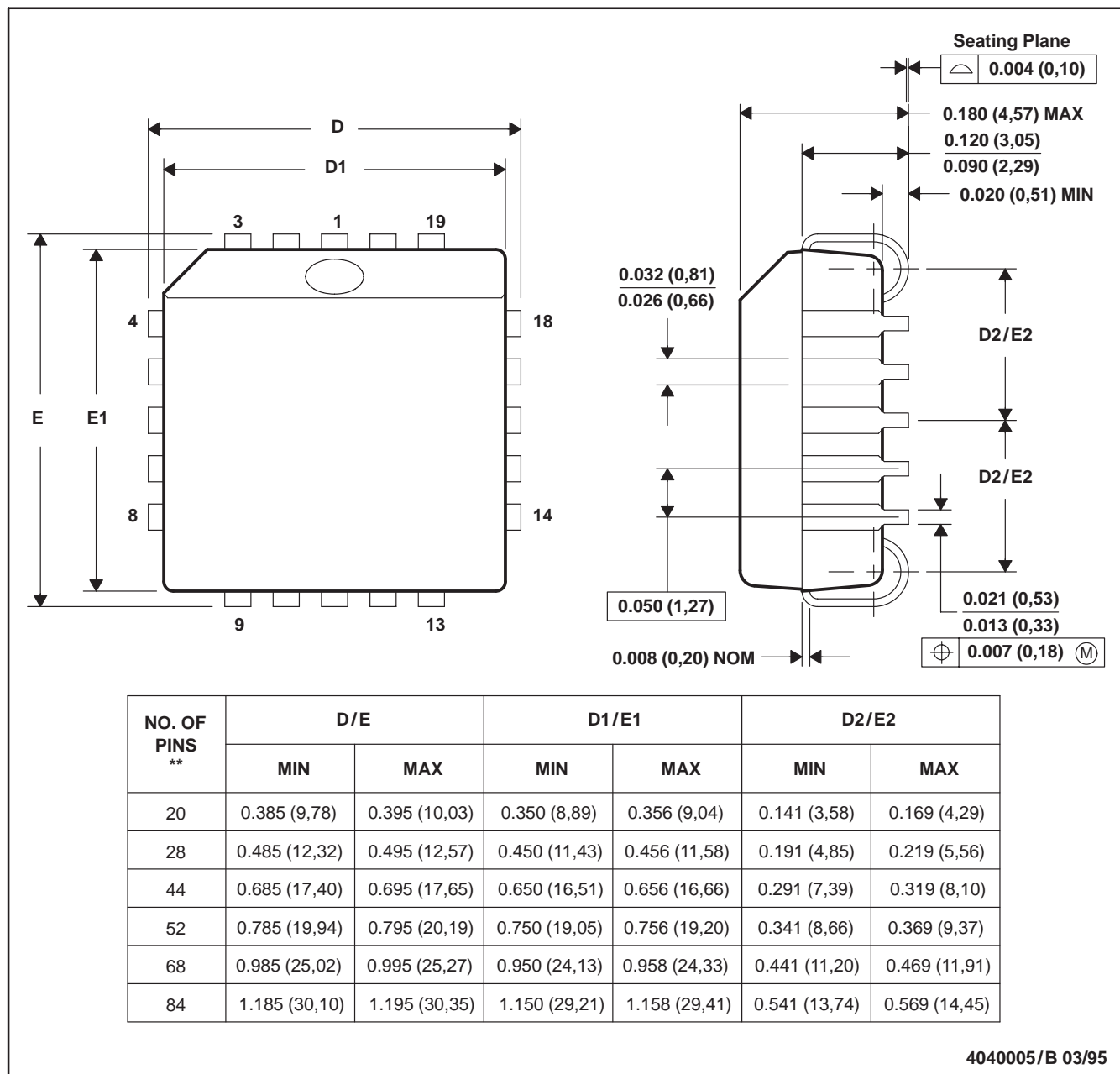

- NOTES: A. All linear dimensions are in inches (millimeters).
 B. This drawing is subject to change without notice.
 C. Falls within JEDEC MS-018

IMPORTANT NOTICE

Texas Instruments Incorporated and its subsidiaries (TI) reserve the right to make corrections, enhancements, improvements and other changes to its semiconductor products and services per JESD46, latest issue, and to discontinue any product or service per JESD48, latest issue. Buyers should obtain the latest relevant information before placing orders and should verify that such information is current and complete. All semiconductor products (also referred to herein as "components") are sold subject to TI's terms and conditions of sale supplied at the time of order acknowledgment.

TI warrants performance of its components to the specifications applicable at the time of sale, in accordance with the warranty in TI's terms and conditions of sale of semiconductor products. Testing and other quality control techniques are used to the extent TI deems necessary to support this warranty. Except where mandated by applicable law, testing of all parameters of each component is not necessarily performed.

TI assumes no liability for applications assistance or the design of Buyers' products. Buyers are responsible for their products and applications using TI components. To minimize the risks associated with Buyers' products and applications, Buyers should provide adequate design and operating safeguards.

TI does not warrant or represent that any license, either express or implied, is granted under any patent right, copyright, mask work right, or other intellectual property right relating to any combination, machine, or process in which TI components or services are used. Information published by TI regarding third-party products or services does not constitute a license to use such products or services or a warranty or endorsement thereof. Use of such information may require a license from a third party under the patents or other intellectual property of the third party, or a license from TI under the patents or other intellectual property of TI.

Reproduction of significant portions of TI information in TI data books or data sheets is permissible only if reproduction is without alteration and is accompanied by all associated warranties, conditions, limitations, and notices. TI is not responsible or liable for such altered documentation. Information of third parties may be subject to additional restrictions.

Resale of TI components or services with statements different from or beyond the parameters stated by TI for that component or service voids all express and any implied warranties for the associated TI component or service and is an unfair and deceptive business practice. TI is not responsible or liable for any such statements.

Buyer acknowledges and agrees that it is solely responsible for compliance with all legal, regulatory and safety-related requirements concerning its products, and any use of TI components in its applications, notwithstanding any applications-related information or support that may be provided by TI. Buyer represents and agrees that it has all the necessary expertise to create and implement safeguards which anticipate dangerous consequences of failures, monitor failures and their consequences, lessen the likelihood of failures that might cause harm and take appropriate remedial actions. Buyer will fully indemnify TI and its representatives against any damages arising out of the use of any TI components in safety-critical applications.

In some cases, TI components may be promoted specifically to facilitate safety-related applications. With such components, TI's goal is to help enable customers to design and create their own end-product solutions that meet applicable functional safety standards and requirements. Nonetheless, such components are subject to these terms.

No TI components are authorized for use in FDA Class III (or similar life-critical medical equipment) unless authorized officers of the parties have executed a special agreement specifically governing such use.

Only those TI components which TI has specifically designated as military grade or "enhanced plastic" are designed and intended for use in military/aerospace applications or environments. Buyer acknowledges and agrees that any military or aerospace use of TI components which have **not** been so designated is solely at the Buyer's risk, and that Buyer is solely responsible for compliance with all legal and regulatory requirements in connection with such use.

TI has specifically designated certain components as meeting ISO/TS16949 requirements, mainly for automotive use. In any case of use of non-designated products, TI will not be responsible for any failure to meet ISO/TS16949.

Products

Audio	www.ti.com/audio
Amplifiers	amplifier.ti.com
Data Converters	dataconverter.ti.com
DLP® Products	www.dlp.com
DSP	dsp.ti.com
Clocks and Timers	www.ti.com/clocks
Interface	interface.ti.com
Logic	logic.ti.com
Power Mgmt	power.ti.com
Microcontrollers	microcontroller.ti.com
RFID	www.ti-rfid.com
OMAP Applications Processors	www.ti.com/omap
Wireless Connectivity	www.ti.com/wirelessconnectivity

Applications

Automotive and Transportation	www.ti.com/automotive
Communications and Telecom	www.ti.com/communications
Computers and Peripherals	www.ti.com/computers
Consumer Electronics	www.ti.com/consumer-apps
Energy and Lighting	www.ti.com/energy
Industrial	www.ti.com/industrial
Medical	www.ti.com/medical
Security	www.ti.com/security
Space, Avionics and Defense	www.ti.com/space-avionics-defense
Video and Imaging	www.ti.com/video

TI E2E Community

e2e.ti.com