

# Technical Specification for Small Form Factor Pluggable (SFP)

**SCP6874-GL-#N** (No Diagnostic Monitoring)

**SCP6874-GL-##E** (Diagnostic Monitoring with External Calibration)

- |  |  |   |
|--|--|---|
| <input type="checkbox"/> 155.52Mbps                        | <input type="checkbox"/> 622.08Mbps                          | <input checked="" type="checkbox"/> other <u>1.25Gbps</u>         |
| <input type="checkbox"/> Short Haul                        | <input type="checkbox"/> Long Haul                           | <input checked="" type="checkbox"/> other <u>link budget 22dB</u> |
| <input type="checkbox"/> Intermediate Reach                | <input type="checkbox"/> Long Reach                          | <input type="checkbox"/> other _____                              |
| <input type="checkbox"/> Single 5.0 V                      | <input checked="" type="checkbox"/> Single 3.3 V             | <input type="checkbox"/> other _____                              |
| <input type="checkbox"/> 1.3 μm                            | <input checked="" type="checkbox"/> 1.55 μm                  | <input type="checkbox"/> other _____                              |
| <input checked="" type="checkbox"/> W / Diagnostic Monitor | <input checked="" type="checkbox"/> W / O Diagnostic Monitor |   |

Applicable Part Numbers :

SCP6874-GL-AN, SCP6874-GL-BN, SCP6874-GL-CN, SCP6874-GL-XN, SCP6874-GL-YN, SCP6874-GL-ZN  
 SCP6874-GL-ANE, SCP6874-GL-BNE, SCP6874-GL-CNE, SCP6874-GL-XNE, SCP6874-GL-YNE, SCP6874-GL-ZNE  
 SCP6874-GL-AW, SCP6874-GL-BW, SCP6874-GL-CW, SCP6874-GL-XW, SCP6874-GL-YW, SCP6874-GL-ZW  
 SCP6874-GL-AWE, SCP6874-GL-BWE, SCP6874-GL-CWE, SCP6874-GL-XWE, SCP6874-GL-YWE, SCP6874-GL-ZWE



Sumitomo Electric reserves the right to make changes in this specification without prior notice.

Sumitomo Electric Industries, Ltd. and ExceLight Communications, Inc., have been granted license to the following patents under a license agreement with Finisar Corporation: US 5,019,769, US 6,439,918 B1

**#Safety Precaution Symbols** This specification uses various picture symbols to prevent possible injury to operator or other persons or damage to properties for appropriate use of the product. The symbols and definitions are as shown below. Be sure to be familiar with these symbols before reading this specification.

	<b>Warning</b> Wrong operation without following this instruction may lead to human death or serious injury.
	<b>Caution</b> Wrong operation without following this instruction may lead to human injury or property damage.

Example of picture symbols

indicates prohibition of actions. Action details are explained thereafter.

indicates compulsory actions or instructions. Action details are explained thereafter.

# 1. General

Features and applications of SCP6874-GL are listed below.

## Features

- \* Compliant with SFP MSA. (Alternative options available)
- \* SFF-8472 rev.9 compliant diagnostic monitoring implemented.(SCP6874-GL-##E)
- \* Suitable for '1000 Base-ZX' type Ethernet Applications.
- \* Power Supply Voltage                   Single +3.3V
- \* Compact Package Size                 56.5 X 13.7 X 8.6 mm
- \* Electrical Interface                    AC coupled for DATA, LVTTTL for Tx Disable, open collector output for LOS and Tx Fault. Circuit ground is internally isolated from frame ground.
- \* Distance                                 80km reach (assuming worst case fiber loss of 0.25dB / Km @1550nm)
- \* Link Budget                             22dB
- \* 1550nm DFB-LD
- \* Fiber Coupled Power                   -2 ~ +3dBm ( SMF )
- \* Input Power Range                    -24 ~ - 3dBm ( SMF )
- \* Connector Interface                   LC Duplex Connector
- \* Serial ID Functionality
- \* Tx:Not Shutdown on Tx\_Fault
- \* Alarm and Warning Flags (SCP6874-GL-##E)

## Applications

- \*Switch to switch interface
- \*Switch backbone applications
- \*High speed interface for file servers

# 2. Block Diagram

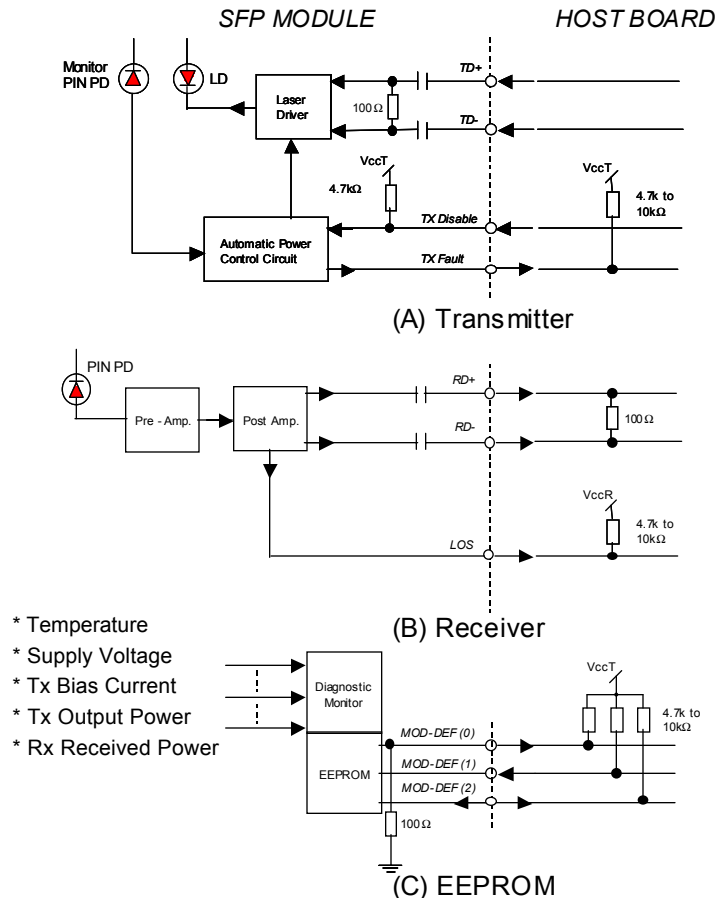

Figure 1. Block Diagram (Diagnostic Monitor is incorporated for SCP6874-GL-##E only.)

## ⚠ Caution

Do not disassemble this product. Otherwise, failure, electrical shock, overheating or fire may occur.

### 3. Package Dimensions

All dimensions are in mm.

\* Refer to section 18 about Part Number Information.

#### 3.1 SCP6874-GL- □ N(E) ( MSA Standard Actuator Type )

X,Y,Z

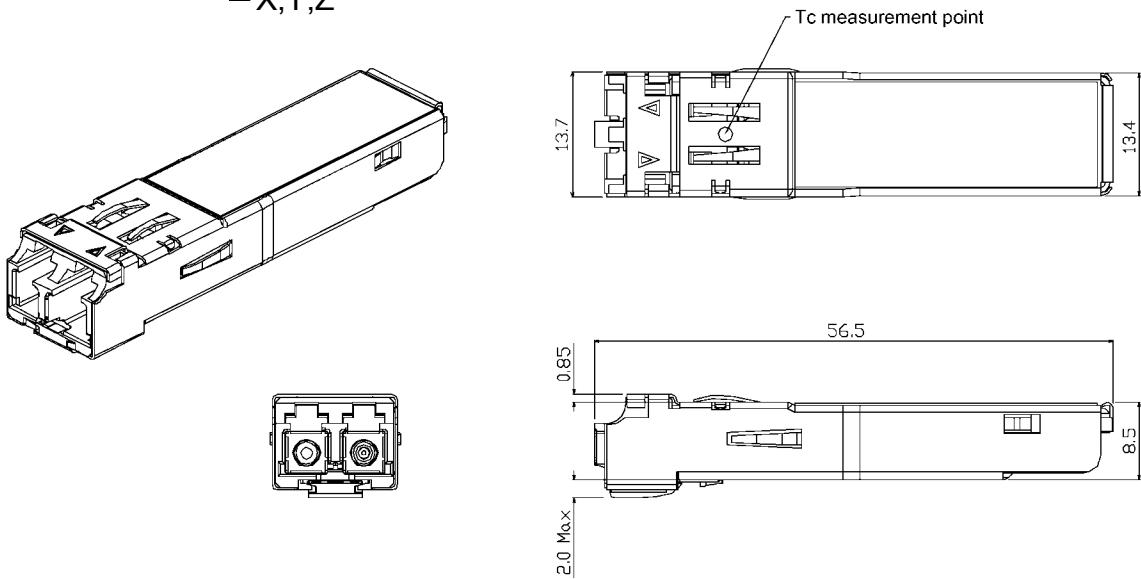

\* Refer to section 18 about Part Number Information.

#### 3.2 SCP6874-GL- □ N(E) ( Bail Actuator Type )

A,B,C

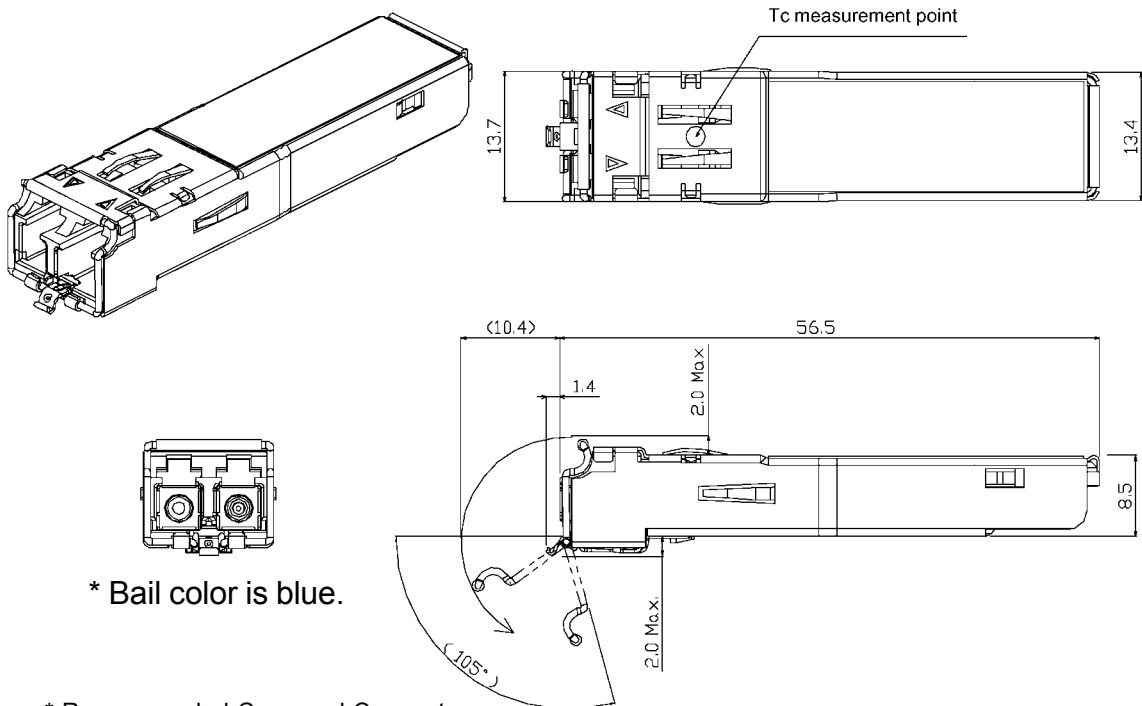

\* Bail color is blue.

\* Recommended Cage and Connector

- Top EMI Cage 1367035-1( Tyco/Electronics:1308292--AMP-04/00 )
- Bottom EMI Cage 1367034-1( Tyco/Electronics:1308292--AMP-04/00 )
- Host Connector 1367073-1( Tyco/Electronics:1308292--AMP-04/00 )

Please refer to their latest specifications.

Figure 2(a). Outline Dimensions

3.3 SCP6874-GL-□ W(E) ( MSA Standard Actuator Type )

X, Y, Z

\* Refer to section18 about Part Number Information.

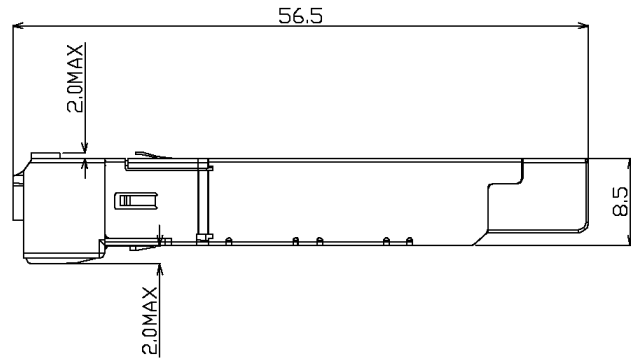
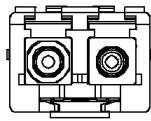
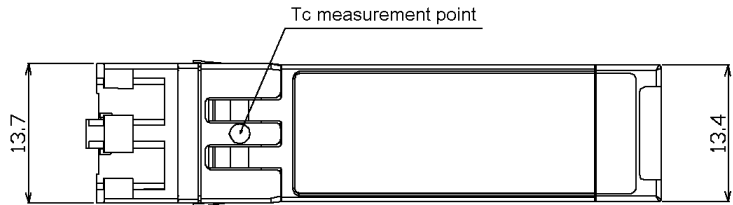
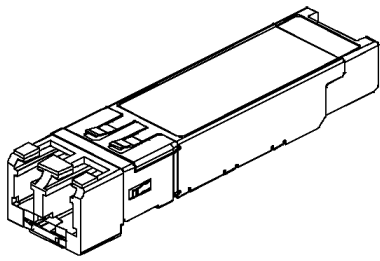

3.4 SCP6874-GL-□ W(E) ( Bail Actuator Type )

A, B, C

\* Refer to section18 about Part Number Information.

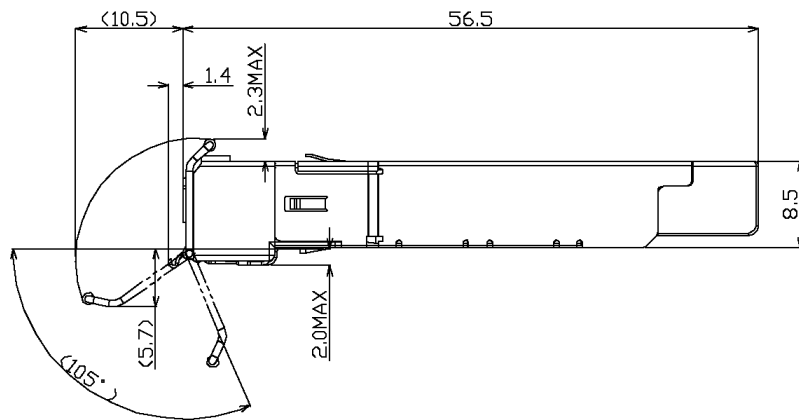
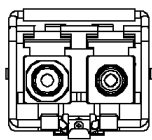
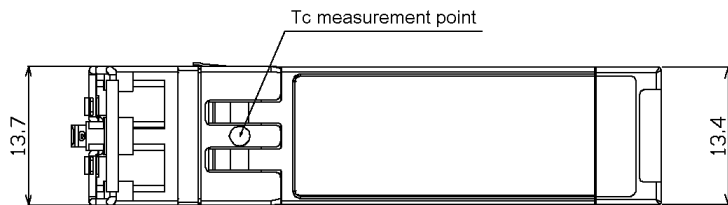
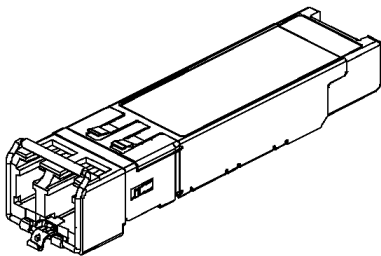

\* Recommended Cage and Connector

- Top EMI Cage 1367035-1( Tyco/Electronics:1308292--AMP-04/00 )
- Bottom EMI Cage 1367034-1( Tyco/Electronics:1308292--AMP-04/00 )
- Host Connector 1367073-1( Tyco/Electronics:1308292--AMP-04/00 )

Please refer to their latest specifications.

Figure 2(b). Outline Dimensions

## 4. Pin Assignment

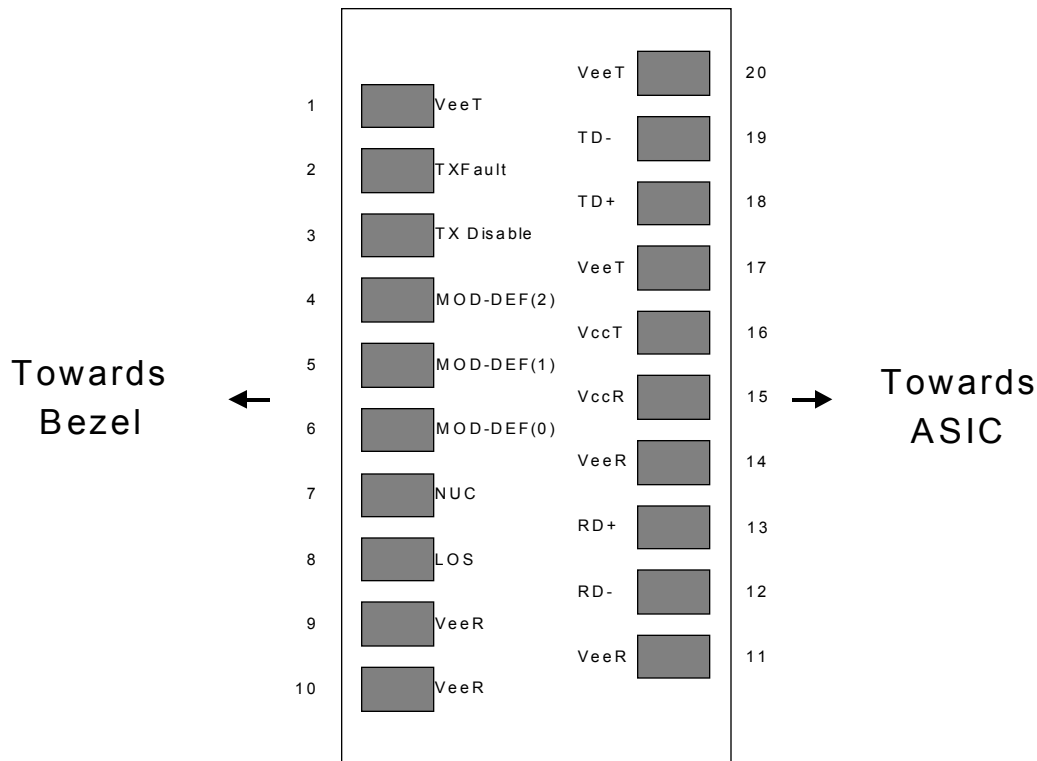

Figure 3. Diagram of Host Board Connector Block Pin Numbers and Names

Pin Num.	Name	Function	Plug Seq.	Notes
1	VeeT	Transmitter Ground	1	
2	TX Fault	Transmitter Fault Indication	3	Note 1
3	TX Disable	Transmitter Disable	3	Note 2 Module disables on high or open
4	MOD-DEF2	Module Definition 2	3	Note 3, 2 wire serial ID and Interface
5	MOD-DEF1	Module Definition 1	3	Note 3, 2 wire serial ID and Interface
6	MOD-DEF0	Module Definition 0	3	Note 3 Grounded internally via 100Ω
7	NUC	NUC	3	No User Connection, reserved for future function.
8	LOS	Loss of Signal	3	Note 4
9	VeeR	Receiver Ground	1	
10	VeeR	Receiver Ground	1	
11	VeeR	Receiver Ground	1	
12	RD-	Inv. Receiver Data Out	3	Note 5
13	RD+	Receiver Data Out	3	Note 5
14	VeeR	Receiver Ground	1	
15	VccR	Receiver Power	2	3.3V± 5%
16	VccT	Transmitter Power	2	3.3V± 5%
17	VeeT	Transmitter Ground	1	
18	TD+	Transmitter Data In	3	Note 6
19	TD-	Inv. Transmitter Data In	3	Note 6
20	VeeT	Transmitter Ground	1	

Plug Seq.: Pin engagement sequence during hot plugging.

## Note

- 1) Tx Fault is an open collector output that shall be pulled up with a 4.7k - 10k $\Omega$  resistor on the host board. Pull up voltage between 2.0V and VccT+0.3V. When high, output indicates a laser fault of some kind. Low indicates normal operation.

Tx Fault is asserted when bias current of laser exceeds the factory-calibrated threshold level.

The laser output is not turned off in case of TX Fault.

- 2) Tx Disable is an input that is used to shut down the transmitter optical output. It is pulled up within the module with a 4.7k $\Omega$  resistor.
- 3) Mod-Def 0,1,2. These are the module definition pins. They should be pulled up with a 4.7k - 10k $\Omega$  resistor on the host board. The pull-up voltage shall be VccT.

Mod-Def 0 indicates that the module is present

Mod-Def 1 is the clock line of two wire serial interface for serial ID

Mod-Def 2 is the data line of two wire serial interface for serial ID

- 4) LOS (Loss of Signal) is an open collector output that shall be pulled up with a 4.7k - 10k $\Omega$  resistor. Pull up voltage between 2.0V and VccR+0.3V. Low indicates normal operation.
- 5) RD-/+ : These are the differential receiver outputs. They are AC coupled 100 $\Omega$  differential lines which should be terminated with 100 $\Omega$  (differential) at the user SERDES. The AC coupling is done inside the module and is thus not required on the host board.
- 6) TD-/+ : These are the differential transmitter inputs. They are AC-coupled, differential lines with 100 $\Omega$  differential termination inside the module. The AC coupling is done inside the module and is thus not required on the host board.

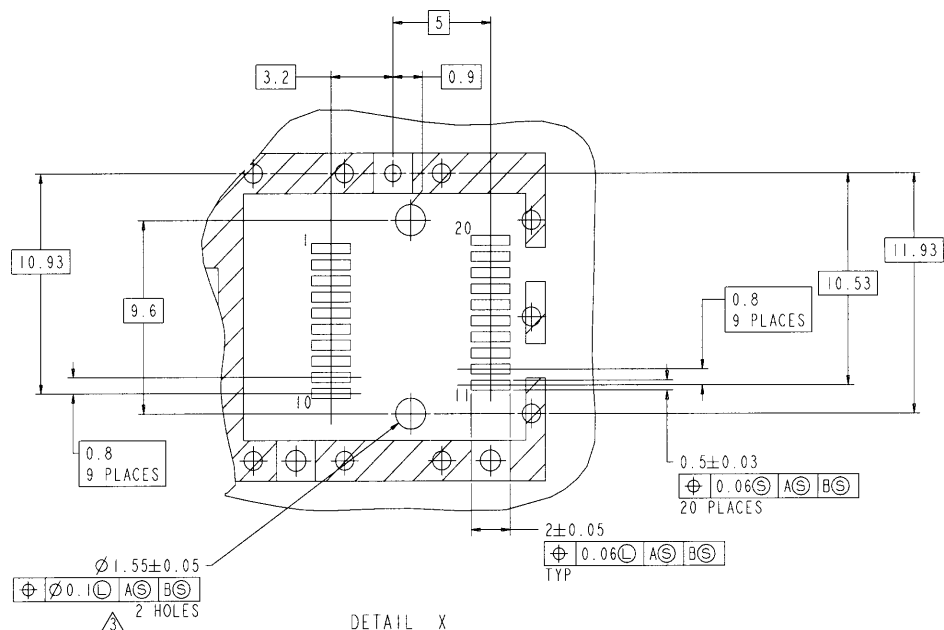

Figure 4. SFP Host Board Mechanical Layout

Notes:

1. Datum and basic dimensions established by customer
2. Pads and vias are chassis ground, 11 places
3. Thru holes, plating optional

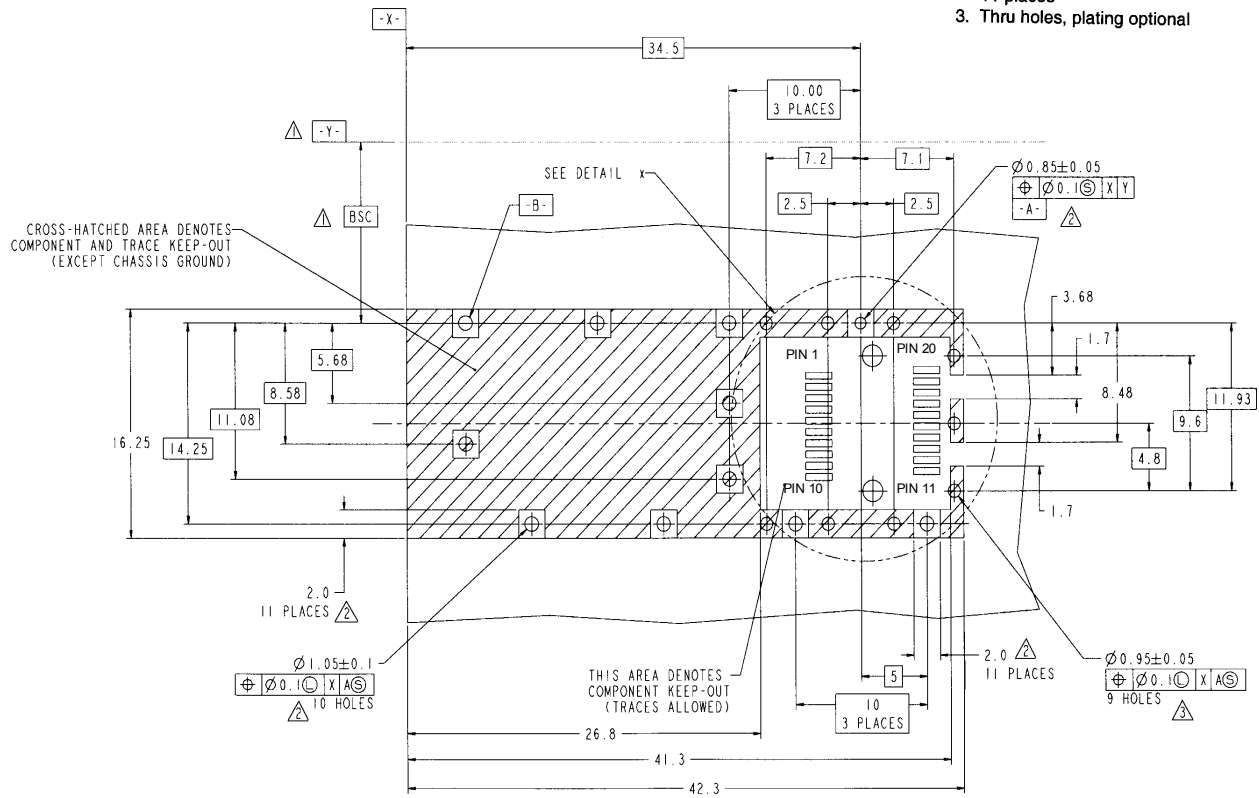
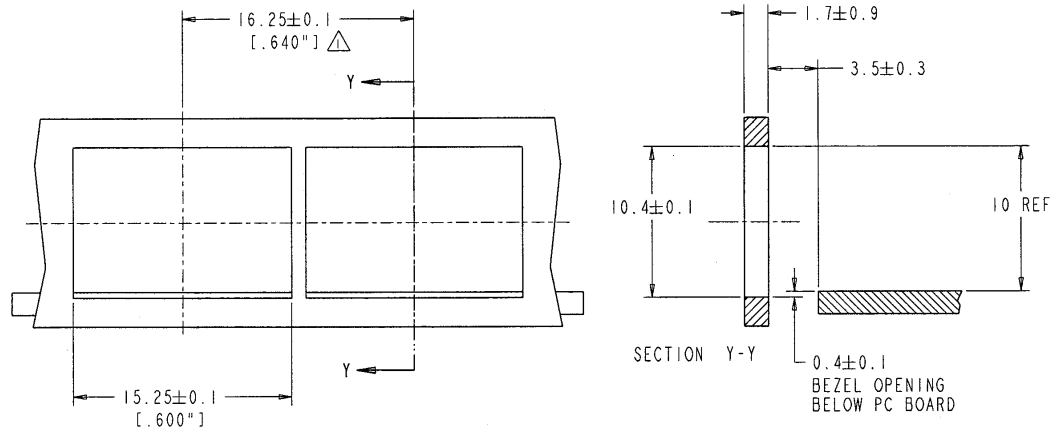

Figure 5. SFP Host Board Mechanical Layout (Cont.)



NOTES:

△ MINIMUM PITCH ILLUSTRATED, ENGLISH DIMENSIONS ARE FOR REFERENCE ONLY

2. NOT RECOMMENDED FOR PCI EXPANSION CARD APPLICATIONS

Figure 6. Recommended Bezel Design

## 5. Absolute Maximum Ratings

Parameter	Symbol	Min.	Typ.	Max.	Unit	Note
Storage Ambient Temperature	Ts	-40		85	°C	1
Operating Ambient Temperature	Ta	-5		70		2
Operating Case Temperature	Tc	-40		85		3
Optical Input Level	Pin			3.0	dBm	
Supply Voltage	VccT,R	0		4.0	V	
Input Voltage	Vi	0		VccT+0.3	V	4
Differential Input Voltage Sw ing (TD+,TD-)	Vin			2.5	Vp-p	

## Notes

1. No condensation allowed. 2. SCP6874-GL-#N(E),Tc=0 to 70degC 3. SCP6874-GL-#W(E) 4. For MOD-DEF (1:2), Tx Disable.

### ⚠ Warning

- ❗ Use the product with the rated voltage described in the specification. If the voltage exceeds the maximum rating, overheating or fire may occur.

### ⚠ Caution

- ⊘ Do not store the product in the area where temperature exceeds the maximum rating, where there is too much moisture or dampness, where there is acid gas or corrosive gas, or other extreme conditions. Otherwise, failure, overheating or fire may occur.

## 6. Electrical Interface

( Unless otherwise specified, VccT,R = 3.135 to 3.465 V and all operating temperature shall apply. )

### 6-1. Operating Characteristics

Parameter	Symbol	Min.	Typ.	Max.	Unit	Note
Supply Voltage	VccT,R	3.135	3.30	3.465	V	
Power Dissipation	Pw			1000	mW	1, 2
				1200		1, 3

## Notes

1. 1250Mbps, PRBS 2<sup>7</sup>-1, NRZ, 50% duty cycle data. 2. SCP6874-GL-#N(E) 3. SCP6874-GL-#W(E)

### 6-2. Transmitter side

Parameter	Symbol	Min.	Typ.	Max.	Unit	Note
Differential Input Voltage Sw ing (TD+,TD-)	Vin	0.3		2.4	Vp-p	1
Input Differential Impedance	Zin	80	100	120	Ω	
Tx Fault	Fault	VfaultH	2.0	VccT+0.3	V	2, 3
	Normal	VfaultL	0	0.8	V	2, 3, 4
Tx Disable	Disable	Vdi	2.0	VccT	V	5
	Enable	Vei	0	0.80	V	
Tdis Input Current	Idi	-1		50	μA	

## Notes

- Refer to Figure 7.
- Tx Fault is pulled up to VccT with a 4.7k - 10kΩ resistor on the host board.  
When high, output indicates a laser fault of some kind. Low indicates normal operation.
- Refer to P.10 about Tx Fault and Tx Shutdown behavior.
- Sink Current : 1mA
- Tx Disable input is internally terminated to VccT via 4.7 kΩ resistor. If pin3 is left open, Tx is disabled.

### 6-3. Receiver side

Parameter	Symbol	Min.	Typ.	Max.	Unit	Note
Differential Output Voltage Sw ing (RD+,RD-)	Vout	0.5		1.2	Vp-p	1
LOS	High	Vloh	2.0	VccR+0.3	V	2
	Low	Vlol	0	0.8		2, 3
Data Rise / Fall Time	tr / tf			240	psec	4

## Notes

- Vcc=+3.3V +/-5%, Output load resistance Rdif=100Ω. Refer to Figure1-(B).  
Refer to Figure7. about definition of differential sw ing.
- LOS is pulled up to VccR with a 4.7k - 10kΩ resistor on the host board. Low indicates normal operation.
- Sink Current : 1mA
- 20~80%, 1250Mbps, PRBS 2<sup>7</sup>-1, 50% duty cycle, NRZ.

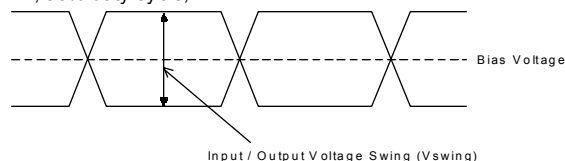

$$\text{Differential Input / Output Voltage Swing (Vin / Vout)} = 2 \times \text{Vswing}$$

Figure 7. Definition of Differential Input / Output Voltage Swing

### 6-4. Module Definition

Parameter		Symbol	Min.	Typ.	Max.	Unit	Note
MOD_DEF(1:2) Input Voltage	High	Vih	0.7VccT		VccT+0.3	V	1
	Low	Vil	0		0.3VccT	V	
MOD_DEF(2) Output Voltage	High	Voh	2.0		VccT	V	1
	Low	Vol1	0		0.4	V	1, 2

Notes

1. They shall be pulled up to VccT with a 4.7k - 10kΩ resistor on the host board.
2. Sink Current : 3mA

### 7. Optical Interface

( Unless otherwise specified, VccT,R = 3.135 to 3.465 V and all operating temperature shall apply. )

#### 7-1. Transmitter side

Parameter	Symbol	Min.	Typ.	Max.	Unit	Note
Bit Rate Range		1.25Gbps +/- 100ppm			Gbps	
Average Output Power to SMF (Enable)	Po	-2.0		+3.0	dBm	1
Average Output Power (Disable)	Pdis			-45.0	dBm	
Extinction Ratio	Er	9.0			dB	
Center Wavelength	λc	1540		1570	nm	
Spectral Width (20dB down)	Δλ			1	nm	
Side Mode Suppression Ratio	SMSR	30			dB	
Eye Mask for Optical Output	Compliant with Eye Mask Defined in IEEE 802.3 standard					
Transmitter Jitter (peak to peak)	TjpkT			227	ps	1, 2
Optical Rise / Fall Time	tr / tf			260	ps	3
Dispersion Penalty	Dp			2.0	dB	4

Notes

1. Measured at 1250Mbps, PRBS2<sup>7</sup>-1, 50% duty cycle, NRZ.
2. TP2 refers to the compliance point specified in IEEE802.3, section 38.2.1.
3. These are unfiltered 20-80% values.
4. Maximum dispersion values correspond to the approximate worst-case dispersion (~1280ps/nm) at 1550nm.

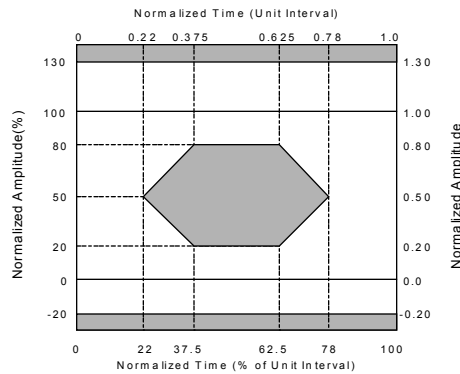

Figure 8. Eye Diagram Mask for Optical Output ( IEEE 802.3 )

### ⚠ Warning



Do not look at the laser beam projection area (e.g. end of optical connector) with naked eyes or through optical equipment while the power is supplied to this product. Otherwise, your eyes may be injured.

#### 7-2. Receiver side

Parameter	Symbol	Min.	Typ.	Max.	Unit	Note
Bit Rate Range		1.25Gbps +/- 100ppm			Gbps	
Center Wavelength	λ	1270		1570	nm	
Minimum Sensitivity	Pmin		-25.0	-24.0	dBm	1, 2, 3
Overload	Pmax	-3.0			dBm	1, 2
LOS Activation Level	PLa	-30.0		-24.5	dBm	2
LOS Deactivation Level	PLd	-29.5		-24.0	dBm	
LOS Hysteresis	Phys	0.5		6.0	dB	
Reflectance	REFr		-14	-12	dB	

Notes

1. BER=10<sup>-12</sup>
2. Measured at 1250Mbps, PRBS 2<sup>7</sup>-1, NRZ
3. With 8.5dB reflection returned signal, degradation of sensitivity is less than 1dB.

### 7-3. Transceiver Timing Characteristics

Parameter	Symbol	Min.	Typ.	Max.	Unit	Note
Tx Disable Assert Time	$t_{off}$			10	us	1
Tx Disable Negate Time	$t_{on}$			1	ms	2
Time to Initialize	$t_{init}$			300	ms	3
Tx Fault Assert Time	$t_{fault}$			100	us	4
Tx Disable to Reset	$t_{reset}$	10			us	5
LOS Assert Time	$t_{loss\_on}$			100	us	6
LOS Deassert Time	$t_{loss\_off}$			100	us	7
Serial ID Clock Rate	$f_{serial\_clock}$			100	kHz	

Notes

1. Time from rising edge of TX Disable to when the optical output falls below 10% of nominal.
2. Time from falling edge of TX Disable to when the modulated optical output rises above 90% of nominal.
3. From power on or negation of TX Fault using TX Disable.
4. Time from power on to TX fault on.
5. Time TX Disable must be held high to reset TX\_fault.
6. Time from LOS state to RX LOS assert.
7. Time from non-LOS state to RX LOS deassert.

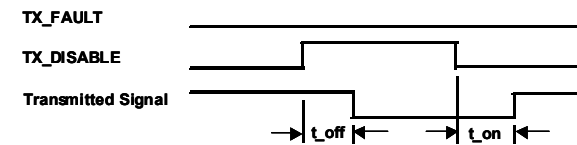

TX\_DISABLE timing during normal operation.

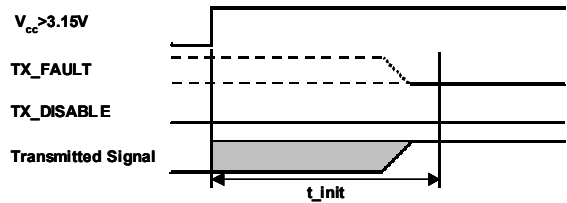

Power on initialization of SFP transceiver, TX\_DISABLE negated

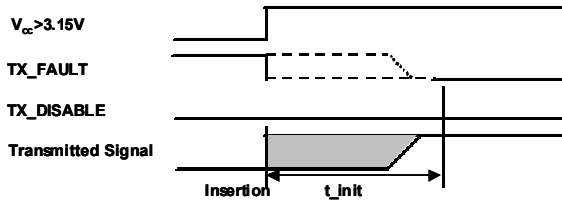

Example of initialization during hot plugging, TX\_DISABLE negated

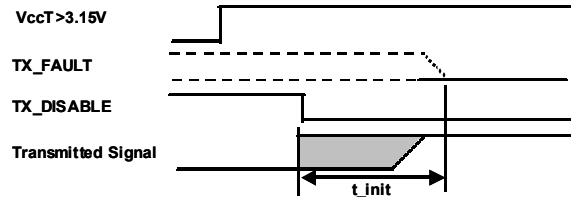

Power on initialization of SFP, TX\_DISABLE asserted

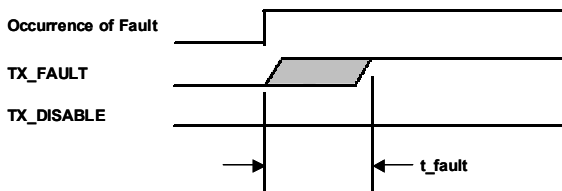

Detection of transmitter safety fault condition

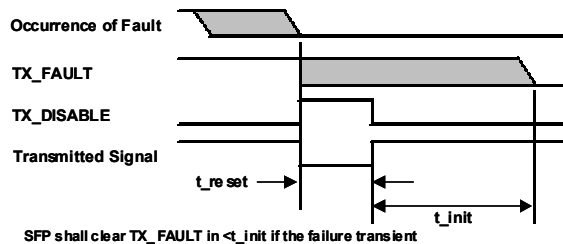

Successful recovery from transient safety fault condition (Except for type "B" and "Y". Refer to next page.)

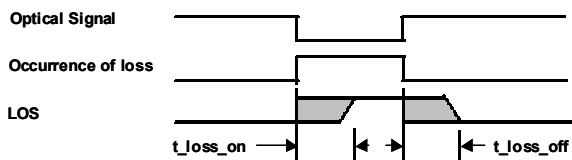

Timing of LOS detection

Figure 9. Transceiver Timing Charts

7-4. Tx\_Fault / Tx Shutdown Options

SCP6874-GL-□ # (E)

└ Actuator and Tx\_Fault Type

Type	Actuator	Tx Fault	Tx Shutdown on Tx Fault
A	Bail	Latched	No
B	Bail	Not Latched	No
C	Bail	Latched	Yes
X	MSA	Latched	Yes
Y	MSA	Not Latched	No
Z	MSA	Latched	No

Type:"A" or "Z"

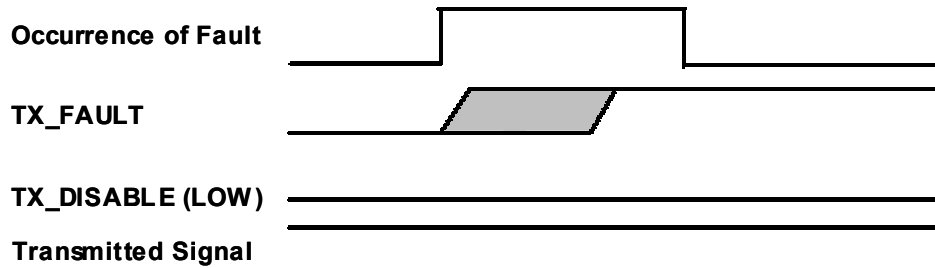

Type:"B" or "Y"

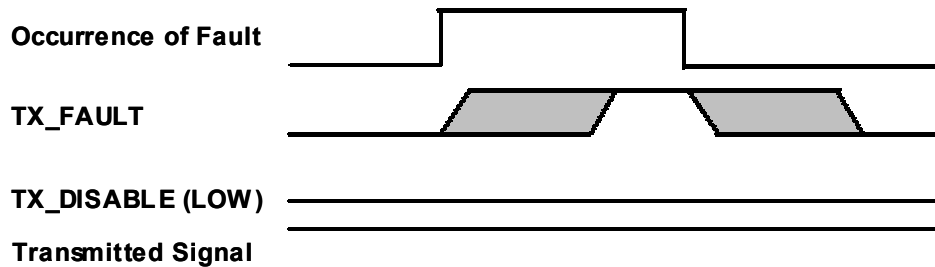

Figure 10. Part Number Identification For Tx\_Fault / Tx Shutdown Behavior

Type:"C" or "X"

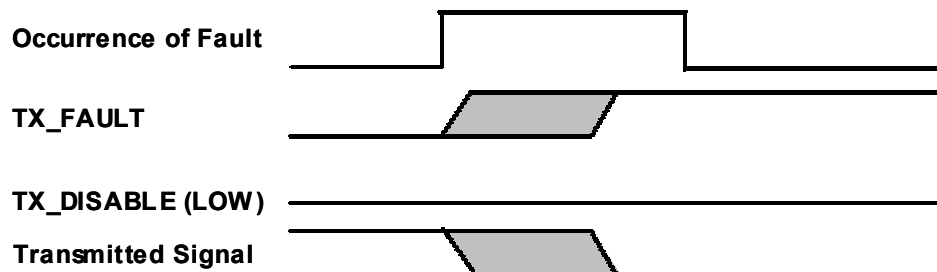

Figure 10. Part Number Identification For Tx\_Fault / Tx Shutdown Behavior

## 8. Digital Diagnostic Memory Map

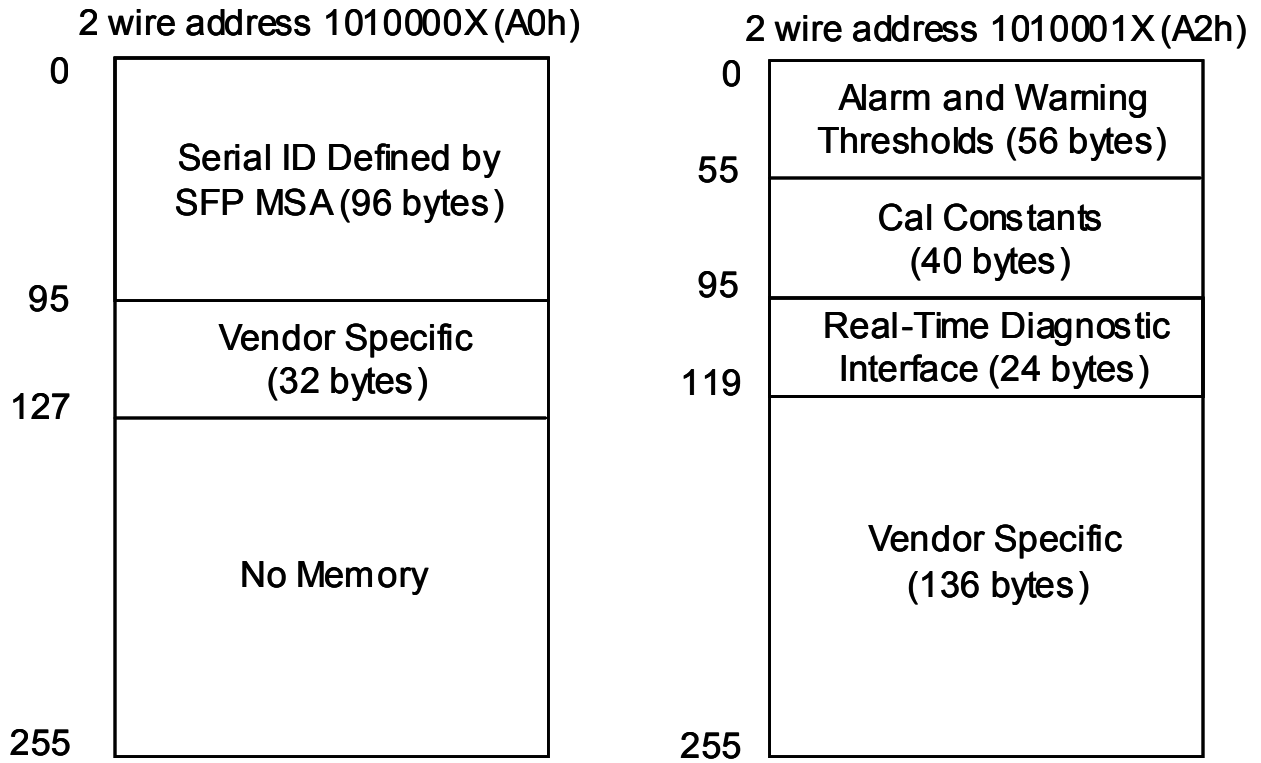

Figure 11. Digital Diagnostic Memory Map(A2h is applicable for SCP6874-GL-#NE.)

## 9. EEPROM Serial ID Memory Contents

The data can be read using the 2-wire serial CMOS EEPROM protocol of the Atmel AT24C01A or equivalent.

2 wire address 1010000X (A0h)

Address	Name of field	Hex	ASCII	Description	
<b>BASE ID FIELDS</b>					
0	Identifier	03		SFP Transceiver	
1	Ext. Identifier	04			
2	Connector	07		LC Connector	
3	Transceiver	00			
4		00			
5		00			
6		40		1000BASE-ZX	
7		00			
8		00			
9	00				
10	00				
11	Encoding	01		8B10B	
12	BR, Nominal	0D		1.25Gbps	
13	Reserved	00			
14	Length(9um) - km	50		80km	
15	Length (9um)	FF			
16	Length (50um)	37		550m	
17	Length (62.5um)	37		550m	
18	Length (Copper)	00			
19	Reserved	00			
20	Vendor name	53	S		
21		75	u		
22		6D	m		
23		69	i		
24		74	t		
25		6F	o		
26		6D	m		
27		6F	o		
28		45	E		
29		6C	l		
30		65	e		
31		63	c		
32		74	t		
33		72	r		
34		69	i		
35		63	c		
36	Reserved	00			
37	Vendor OUI	00			
38		00			
39	5F				
40	Vendor PN	53	S		
41		43	C		
42		50	P		
43		36	6		
44		38	8		
45		37	7		
46		34	4		
47		2D	-		
48		47	G		
49		4C	L		
50		2D	-		
51		41, 42, 43, 58, 59, 5A	A, B, C, X, Y, Z		Actuator and Tx Fault Type
52		4E or 57	N or W		Temperature range
53		45	E		Diagnostics(Ext Cal)
54		20			Non-diagnostics
55		20			
56	Vendor rev	41~5A	A~Z	Variable	
57		20			
58		20			
59		20			
60	Wavelength	06		1550nm	
61	Reserved	0E			
62	Reserved	00			
63	CC BASE	Note1			

Address	Name of field	Hex	ASCII	Description
<b>EXTENDED ID FIELDS</b>				
64	Options	00		
65		1A		
66	BR, max	00		
67	BR, min	00		
68	Vendor SN	Note2		Year
69				Month
70				
71				
72				
73				
74				
75				
76				
77				
78				
79				
80				
81				
82				
83				
84	Date code	Note3		
85				
86				
87				
88				
89				
90				
91				
92	Diagnostic Monitoring Type	58(Note 4)		Diagnostics(Ext Cal)
		80		Non-diagnostics
93	Enhanced Options	B0(Note 4)		Diagnostics
		00		Non-diagnostics
94	SFF-8472 Compliance	01		Diagnostics
		00		Non-diagnostics
95	CC EXT	Note5		
<b>VENDOR SPECIFIC ID FIELDS</b>				
96	Read-only	20		
97		20		
98		20		
99		20		
100		20		
101		20		
102		20		
103		20		
104		20		
105		20		
106		20		
107		20		
108		20		
109		20		
110		20		
111		20		
112		20		
113		20		
114		20		
115		20		
116	20			
117	20			
118	20			
119	20			
120	20			
121	20			
122	20			
123	20			
124	20			
125	20			
126	20			
127	20			

Note1. Address 63 is check sum of bytes 0-62 Note2. Address 68-83 Vendor Serial Number  
 Note3. Address 84-91 Date code Note4. Refer to Section 10. (Enhanced Monitoring Function)  
 Note5. Address 95 is check sum of bytes 64-94

## 10. Enhanced Monitoring Functions (SCP6874-GL-###E)

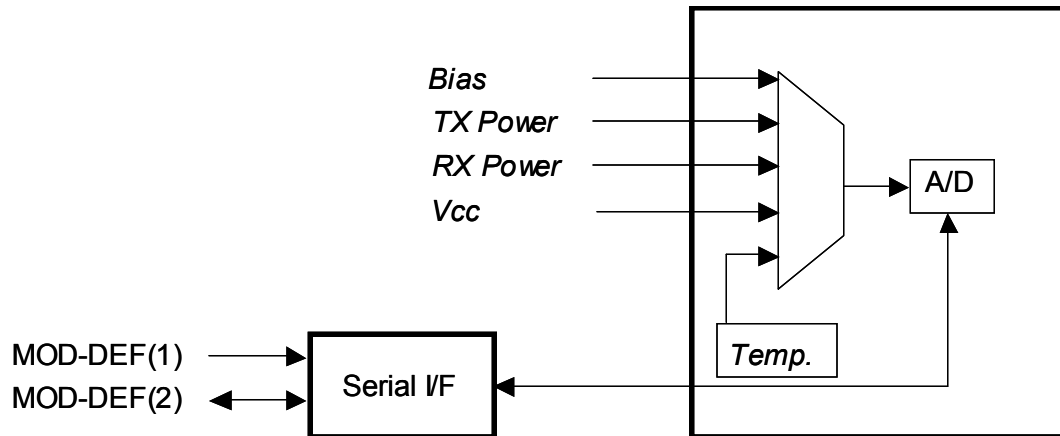

Figure 12. Block Diagram

Diagnostic Monitoring Type, 2 wire address A0h

Data Address	Bits	Description	Status(SEI)
92	7	Reserved for legacy diagnostic implementations. Must be '0' for compliance with SFF-8472.	0
92	6	Digital diagnostic monitoring implemented (described in SFF-8472). Must be '1' for compliance with SFF-8472.	1
92	5	Internally Calibrated	0
92	4	Externally Calibrated	1
92	3	Received power measurement type 0 = OMA, 1 = Average Power	1
92	2	Address change required. (Refer to SFF-8472)	0
92	1-0	Reserved	0

Enhanced Options, 2 wire address A0h

Data Address	Bits	Description	Status(SEI)
93	7	Optional Alarm/warning flags implemented for all monitored quantities	1
93	6	Optional Soft TX_DISABLE control and monitoring implemented	0
93	5	Optional Soft TX_FAULT monitoring implemented	1
93	4	Optional Soft RX_LOS monitoring implemented	1
93	3	Optional Soft RATE_SELECT control and monitoring implemented	0
93	2-0	Reserved	0

## 11. Calibration Calculation (SCP6874-GL-###E)

Calibration constants for External Calibration Option, 2 wire address A2h

Address	#Bytes	Name	Description
56-59	4	RP <sub>4</sub>	Single precision floating-point calibration data for received power. Byte 56 is MSB. Byte 59 is LSB.
60-63	4	RP <sub>3</sub>	Single precision floating-point calibration data for received power. Byte 60 is MSB. Byte 63 is LSB.
64-67	4	RP <sub>2</sub>	Single precision floating-point calibration data for received power. Byte 64 is MSB. Byte 67 is LSB.
68-71	4	RP <sub>1</sub>	Single precision floating-point calibration data for received power. Byte 68 is MSB. Byte 71 is LSB.
72-75	4	RP <sub>0</sub>	Single precision floating-point calibration data for received power. Byte 72 is MSB. Byte 75 is LSB.
76-77	2	I <sub>SLOPE</sub>	Unsigned fixed-point calibration data for laser bias current. Byte 76 is MSB. Byte 77 is LSB.
78-79	2	I <sub>OFFSET</sub>	16-bit signed 2's complement calibration data for laser bias current. Byte 78 is MSB. Byte 79 is LSB.
80-81	2	TP <sub>SLOPE</sub>	Unsigned fixed-point calibration data for laser output power. Byte 80 is MSB. Byte 81 is LSB.
82-83	2	TP <sub>OFFSET</sub>	16-bit signed 2's complement calibration data for laser output power. Byte 82 is MSB. Byte 83 is LSB.
84-85	2	T <sub>SLOPE</sub>	Unsigned fixed-point calibration data for transceiver temperature. Byte 84 is MSB. Byte 85 is LSB.
86-87	2	T <sub>OFFSET</sub>	16-bit signed 2's complement calibration data for transceiver temperature. Byte 86 is MSB. Byte 87 is LSB.
88-89	2	V <sub>SLOPE</sub>	Unsigned fixed-point calibration data for supply voltage. Byte 88 is MSB. Byte 89 is LSB.
90-91	2	V <sub>OFFSET</sub>	16-bit signed 2's complement calibration data for supply voltage. Byte 90 is MSB. Byte 91 is LSB.
92-94	3	Reserved	Reserved
95	1	Checksum	Byte 95 contains the low order 8 bits of the sum at data address bytes 0-94.

**Transceiver temperature:** Temperature, T, is given by

$$T = T_{SLOPE} * T_{AD} + T_{OFFSET}$$

Where T<sub>AD</sub> is 16-bit signed 2's complement A/D value at bytes 96-97, T<sub>SLOPE</sub> is unsigned fixed-point value at bytes 84-85 and T<sub>OFFSET</sub> is signed 2's complement value with LSB equal to 1/256 deg-C at bytes 86-87. The result, T, is 16-bit signed 2's complement value with LSB equal to 1/256 deg-C. The monitored output is the junction temperature of the diode inside the transceiver, hence, there is some discrepancy between the output and transceiver case temperature of the point illustrated in section 3 mechanical dimension.

**Supply voltage:** Voltage, V, is given by

$$V = V_{\text{SLOPE}} * V_{\text{AD}} + V_{\text{OFFSET}}$$

Where  $V_{\text{AD}}$  is 16-bit unsigned A/D value at bytes 98-99,  $V_{\text{SLOPE}}$  is unsigned fixed-point value at bytes 88-89 and  $V_{\text{OFFSET}}$  is signed 2's complement value with LSB equal to 100  $\mu\text{V}$  at bytes 90-91. The result, V, is 16-bit unsigned value with LSB equal to 100  $\mu\text{V}$ .

**Laser bias current:** Current, I, is given by

$$I = I_{\text{SLOPE}} * I_{\text{AD}} + I_{\text{OFFSET}}$$

Where  $I_{\text{AD}}$  is 16-bit unsigned A/D value at bytes 100-101,  $I_{\text{SLOPE}}$  is unsigned fixed-point value at bytes 76-77 and  $I_{\text{OFFSET}}$  is signed 2's complement value with LSB equal to 2  $\mu\text{A}$  at bytes 78-79. The result, I, is 16-bit unsigned value with LSB equal to 2  $\mu\text{A}$ .

**Laser output power:** Power, TP, is given by

$$TP = TP_{\text{SLOPE}} * TP_{\text{AD}} + TP_{\text{OFFSET}}$$

Where  $TP_{\text{AD}}$  is 16-bit unsigned A/D value at bytes 102-103,  $TP_{\text{SLOPE}}$  is unsigned fixed-point value at bytes 80-81 and  $TP_{\text{OFFSET}}$  is signed 2's complement value with LSB equal to 0.1  $\mu\text{W}$  at bytes 82-83. The result, TP, is 16-bit unsigned value with LSB equal to 0.1  $\mu\text{W}$ .

**Received power:** Power, RP, is given by

$$RP = RP_4 * RP_{\text{AD}}^4 + RP_3 * RP_{\text{AD}}^3 + RP_2 * RP_{\text{AD}}^2 + RP_1 * RP_{\text{AD}} + RP_0$$

Where  $RP_{\text{AD}}$  is 16-bit unsigned A/D value at bytes 104-105 and  $RP_4$ ,  $RP_3$ ,  $RP_2$ ,  $RP_1$  and  $RP_0$  are single precision floating-point values at bytes 56-75. The result, RP, is 16-bit unsigned value with LSB equal to 0.1  $\mu\text{W}$ .

A/D Accuracy, 2 wire address A2h

<b>Data Address</b>	<b>Parameter</b>	<b>Accuracy</b>	<b>Units Display</b>	<b>Note</b>
96-97	Temperature	+/-3 deg-C	Signed 2's complement integer deg-C	Junction temperature of monitoring IC.
98-99	Vcc	+/-3%	x100 $\mu\text{Volt}$	
100-101	TX Bias	+/-10%	x2 $\mu\text{A}$	Specified by nominal value
102-103	TX Power	+/-3dB	x0.1 $\mu\text{W}$	-2~+3dBm
104-105	RX Power	+/-3dB ( -24~-3dBm )	x0.1 $\mu\text{W}$	At specified transmitter wavelength ( Section 7-1 )

## 12. A/D Values and Status (SCP6874-GL-##E)

Converted analog values, 2wire address A2h

Byte	Bit	Name	Description
96	All	Temperature MSB	Signed 2's complement integer temperature(-40 to +125C) Based on internal temperature measurement
97	All	Temperature LSB	Fractional part of temperature(count/256)
98	All	Vcc MSB	Internally measured supply voltage in transeiver.
99	All	Vcc LSB	Actual voltage is full 16 bit value *100 $\mu$ Volt.(Yields range of 0-6.55V)
100	All	TX Bias MSB	Measured Laser Bias Current in mA. Bias current is full
101	All	TX Bias LSB	16 bit value *2 $\mu$ A.(Full range of 0-131mA)
102	All	TX Power MSB	Measured TX output power in mW. TX power is full 16
103	All	TX Power LSB	bit value*0.1 $\mu$ W.(Full range of -40 to+8.2dBm)
104	All	RX Power MSB	Measured RX input power in mW. RX power is full 16
105	All	RX Power LSB	bit value*0.1 $\mu$ W.(Full range of -40 to+8.2dBm)
106-109	All	Reserved	

Optional Status Bits, 2wire address A2h

Byte	Bit	Name	Description
110	0	Data_Ready_Bar	Indicates transeiver has achieved power up and data is ready. Bit remains high until data is ready to be read at which time the device sets the bit low.

## 13. Alarm and Warning Flags (SCP6874-GL-##E)

Alarm and Warning Flags, 2wire address A2h

Byte	Bit	Name	Description
112	7	Temp High Alarm	Set when internal temperature exceeds high alarm level.
112	6	Temp Low Alarm	Set when internal temperature is below low alarm level.
112	5	Vcc High Alarm	Set when internal supply voltage exceeds high alarm level.
112	4	Vcc Low Alarm	Set when internal supply voltage is below low alarm level.
112	3	TX Bias High Alarm	Set when TX Bias current exceeds high alarm level.
112	2	TX Bias Low Alarm	Set when TX Bias current is below low alarm level.
112	1	TX Power High Alarm	Set when TX output power exceeds high alarm level.
112	0	TX Power Low Alarm	Set when TX output power is below low alarm level.
113	7	RX Power High Alarm	Set when Received Power exceeds high alarm level.
113	6	RX Power Low Alarm	Set when Received Power is below low alarm level.
113	5-0	Reserved	
114	All	Reserved	
115	All	Reserved	
116	7	Temp High Warning	Set when internal temperature exceeds high warning level.
116	6	Temp Low Warning	Set when internal temperature is below low warning level.
116	5	Vcc High Warning	Set when internal supply voltage exceeds high warning level.
116	4	Vcc Low Warning	Set when internal supply voltage is below low warning level.
116	3	TX Bias High Warning	Set when TX Bias current exceeds high warning level.
116	2	TX Bias Low Warning	Set when TX Bias current is below low warning level.
116	1	TX Power High Warning	Set when TX output power exceeds high warning level.
116	0	TX Power Low Warning	Set when TX output power is below low warning level.
117	7	RX Power High Warning	Set when Received Power exceeds high warning level.
117	6	RX Power Low Warning	Set when Received Power is below low warning level.
117	5-0	Reserved	
118	All	Reserved	
119	All	Reserved	

### 14. Recommended Interface Circuit

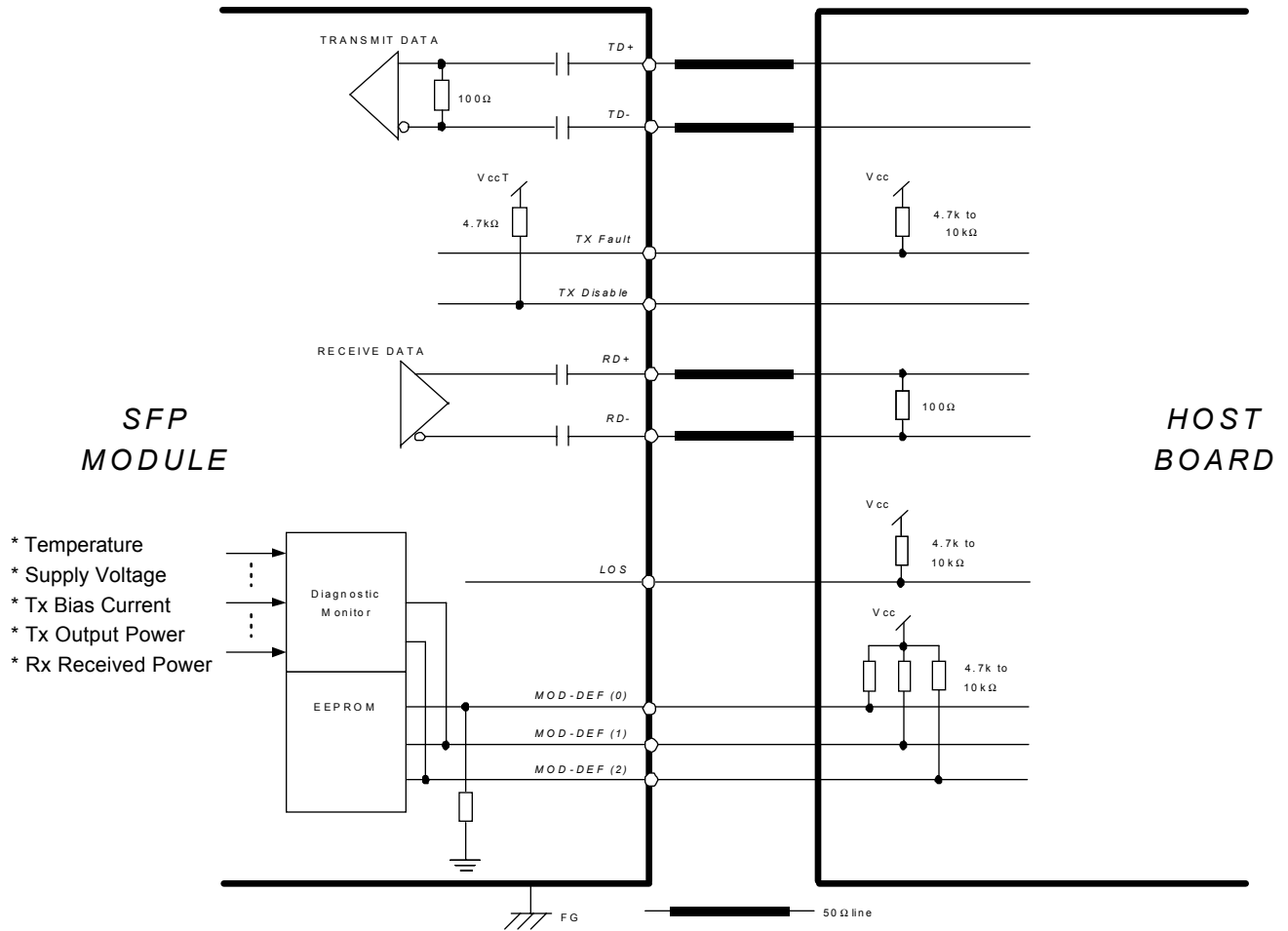

Figure 13. Recommended Interface Circuit (Diagnostic Monitor is incorporated for SCP6874-GL-##E only.)

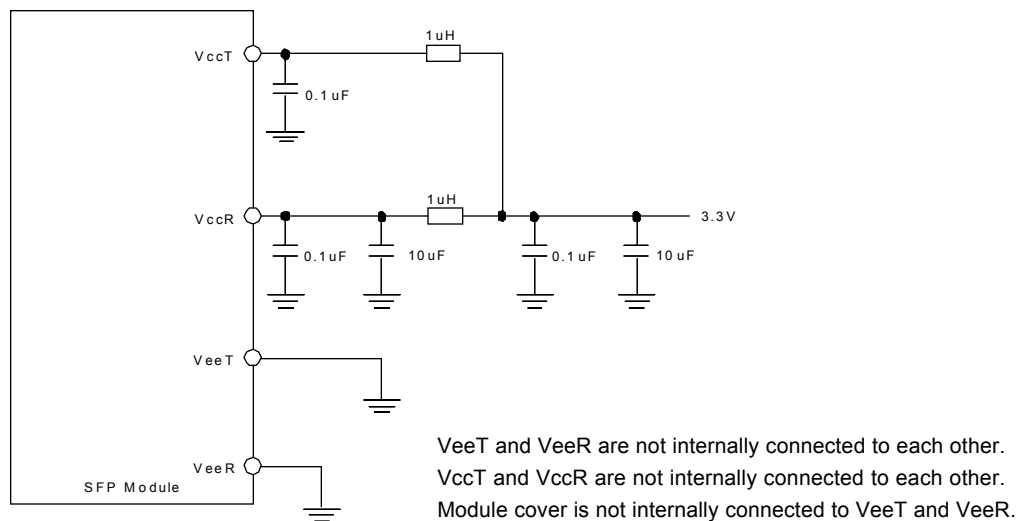

Figure 14. Recommended Supply Filtering Network

## 15. Reliability Test Program

GR-468-CORE Issue 1, December 1998 Laser Module

HEADING	TEST	REFERENCE	CONDITIONS	SAMPLING		
				LTPD	SS	C
Mechanical Integrity	Mechanical Shock	MIL-STD-883 Method 2002	5 times/axis 1,500G, 0.5ms	20	11	0
	Vibration	MIL-STD-883 Method 2007	Cond. A 20G, 20-2,000 Hz, 4min/cy, 4cy/axis	20	11	0
	Thermal Shock	MIL-STD-883 Method 1011	Delta T=100°C 0°C to 100°C	20	11	0
Endurance	Accel. Aging (High Temp.)	(R)-4-53 Section 5.18	85°C; rated power 1,000 hrs. for pass/fail 2,000, 5,000 hrs. for info.	-	25 10	-
	Low Temp. Storage	-	min. storage T 1,000 hrs. for pass/fail 2,000 hrs. for info.	20	11	0
	Temperature Cycling	Section 5.20	-40°C to +85°C 500 for pass/fail 1,000 for info.	20 -	11 11	0 -
	Damp Heat	MIL-STD-202 Method 103 or IEC-60068-2-3	85°C/85%RH 1,000hrs.	20	11	0
	Cyc. Moist. Res.	Section 5.23	-	20	11	0
Special Tests	Internal Moisture	MIL-STD-883 Method 1018	Max. 5,000ppm water vapour	20	11	0
	ESD Threshold	Section 5.22	-	-	6	-

SS : Sample Size

C : Maximum number of failure allowed to pass the test.

## 16. Laser Safety

This product uses a semiconductor laser system and is a laser class 1 product acceptable FDA, complies with 21CFR 1040. 10 and 1040.11. Also this product is a laser class 1 product acceptable IEC 60825.

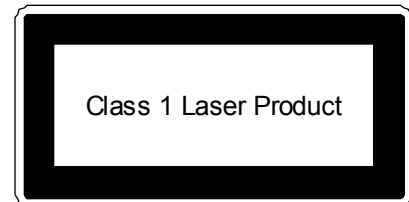

### ⚠ Caution



If this product is used under conditions not recommended in the specification or this product is used with unauthorized revision, classification for laser product safety standard is invalid. Classify the product again at your responsibility and take appropriate actions.

## 17. Other Precaution

Under such a strong vibration environment as in automobile, the performance and reliability are not guaranteed. The governmental approval is required to export this product to other countries. To dispose of these components, the appropriate procedure should be taken to prevent illegal exportation.

This module must be handled, used and disposed of according to your company's safe working practice.

**⚠ Warning**

⊘ Do not put this product or components of this product into your mouth. This product contains material harmful to health.

**⚠ Caution.**

⊘ Dispose this product or equipment including this product properly as an industrial waste according to the regulations.

**18. Ordering Information**

SCP6874 - GL - **a** **b** **c** ( LC Duplex Receptacle, Metallized )

Diagnostic Monitor / Calibration Type

Blank: No Diagnostic Monitoring

E :Diagnostic Monitoring with External Calibration

Operating Temperature

N : Ta=-5 to 70°C (Tc=0 to 70°C)

W : Tc=-40 to 85°C

Actuator and Tx Fault Type

Type	Actuator	Tx Fault	Tx Shutdown on Tx Fault	Part Number on Label
A	Bail	Latched	No	SCP6874-GL-A <b>a</b> <b>b</b> <b>c</b>
B	Bail	Not Latched	No	SCP6874-GL-B <b>a</b> <b>b</b> <b>c</b>
C	Bail	Latched	Yes	SCP6874-GL-C <b>a</b> <b>b</b> <b>c</b>
X	MSA	Latched	Yes	SCP6874-GL-X <b>a</b> <b>b</b> <b>c</b>
Y	MSA	Not Latched	No	SCP6874-GL-Y <b>a</b> <b>b</b> <b>c</b>
Z	MSA	Latched	No	SCP6874-GL-Z <b>a</b> <b>b</b> <b>c</b>

**19. For More Information**

U.S.A.

ExcelLight Communications

4021 Stirrup Creek Drive, Suite 200 Durham, NC 27703 USA

Tel. +1-919-361-1600 / Fax. +1-919-361-1619

E-mail: [info@excelight.com](mailto:info@excelight.com)

<http://www.excelight.com>

Europe

Sumitomo Electric Europe Ltd.

220 Centennial Park, Elstree, Herts, WD6 3SL UK

Tel. +44-208-953-8681 / Fax. +44-208-207-5950

E-mail: [photonics@sumielectric.com](mailto:photonics@sumielectric.com)

<http://www.sumielectric.com>

Japan

Sumitomo Electric Industries, Ltd.

1 Taya-cho, Sakae-ku, Yokohama, 244-8588 Japan

Tel. +81-45-853-7154 / Fax. +81-45-851-1932

E-mail: [product-info@ppd.sei.co.jp](mailto:product-info@ppd.sei.co.jp)

[http://www.sei.co.jp/Electro-optic/index\\_e.html](http://www.sei.co.jp/Electro-optic/index_e.html)

(SCP6874-GL)