

DISTINCTIVE CHARACTERISTICS

- Ideal for low power sensitive applications
- Low standby power (normal and reverse)
- Automatic on-chip battery switching
- On-chip thermal management
- On-chip thermal shutdown
- -20 V to -60 V battery operation
- Programmable current limit
- Programmable resistive feed
- Programmable loop-detect threshold
- Selectable overhead for metering applications
- Two-wire impedance set by single external impedance
- On-chip ring and test relay drivers and relay snubber circuits
- Polarity reversal (full transmission)
- Loop and ground-key detector
- Comparator for ring-trip detection
- Ground-start capability
- On-hook transmission

BLOCK DIAGRAM

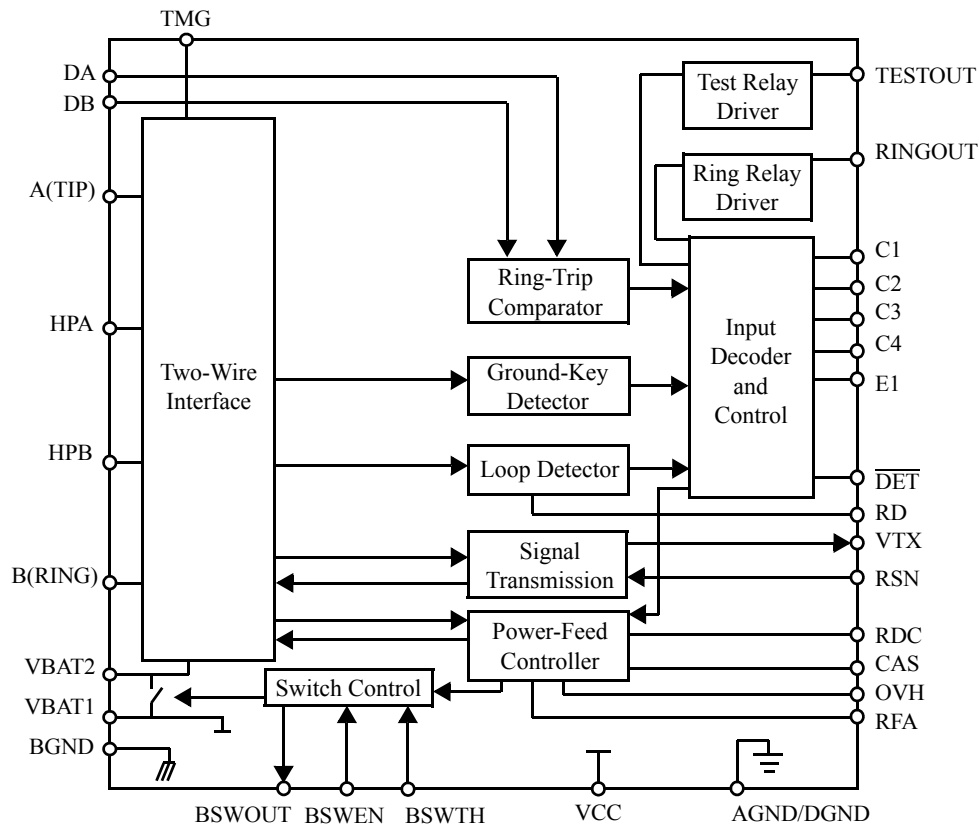

ORDERING INFORMATION

Standard Products

Legerity standard products are available in several packages and operating ranges. The order number (Valid Combination) is formed by a combination of the elements below.

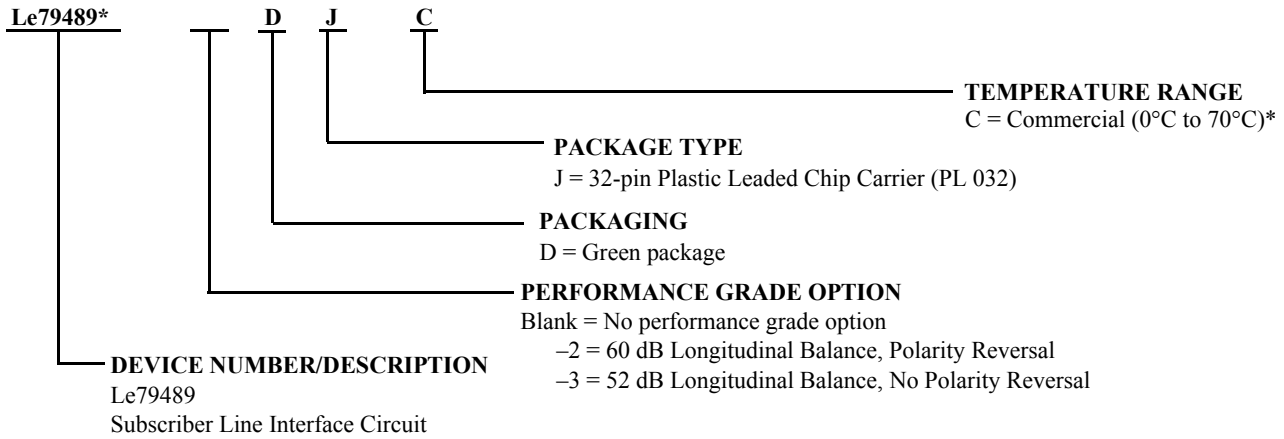

Valid Combinations		
Le79489*	(Blank)	DJC ^{1, 2}
	-2	
	-3	

Valid Combinations

Valid Combinations list configurations planned to be supported in volume for this device. Contact Legerity sales to confirm availability of specific valid combinations and to obtain additional data on Legerity's standard military-grade products.

1. For delivery using a tape and reel packing system, add a "T" suffix to the OPN (Ordering Part Number) when placing an order.
2. The green package meets RoHS Directive 2002/95/EC of the European Council to minimize the environmental impact of electrical equipment.

**Legerity reserves the right to fulfill all orders for this device with parts marked with the "Am" part number prefix, until such time as all inventory bearing this mark has been depleted. It should be noted that parts marked with either the "Am" or the "Le" part number prefix are equivalent devices in terms of form, fit, and function. The only difference between the two is in the part number prefix appearing on the topside mark.*

CONNECTION DIAGRAMS

Top View

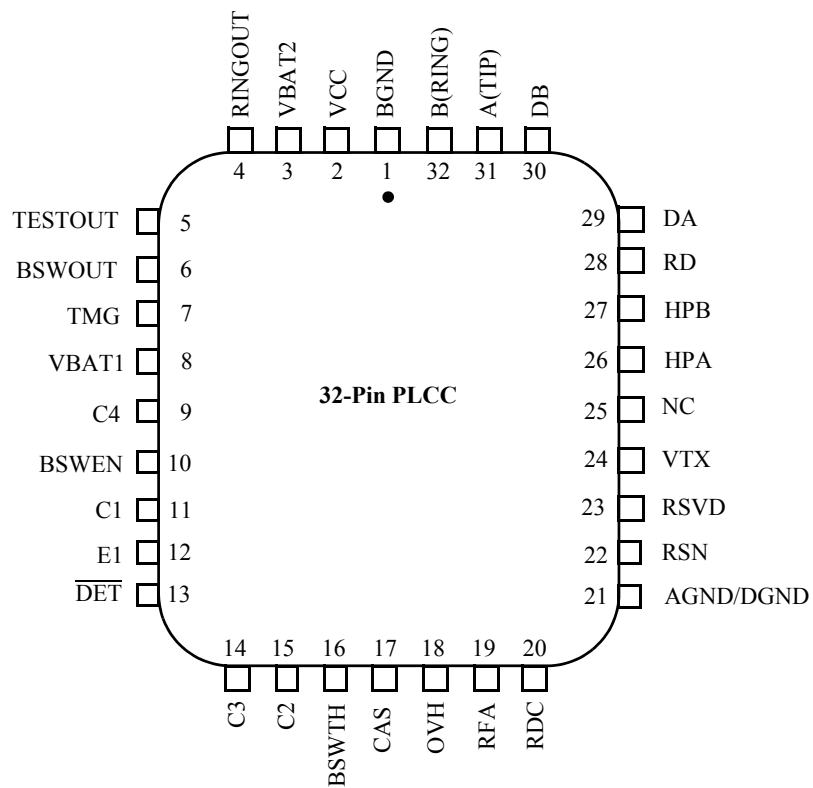

Notes:

1. Pin 1 is marked for orientation.
2. NC = No Connect
3. RSVD = Reserved. Do not connect to this pin.

PIN DESCRIPTIONS

Pin Names	Type	Description
AGND/DGND	Gnd	Analog and Digital ground.
A(TIP)	Output	Output of A(TIP) power amplifier.
BGND	Gnd	Battery (power) ground.
B(RING)	Output	Output of B(RING) power amplifier.
BSWEN	—	Battery Switch Control. Internally connected to automatic battery switch circuitry. BSWEN can be overridden by external logic. BSWEN Low connects VBAT1 to VBAT2. BSWEN High disconnects VBAT1 from VBAT2.
BSWOUT	Output	Buffered Output. Internally connected to battery switch circuitry. The output is open-collector with a built-in pull-up resistor. BSWOUT Low indicates VBAT1 is connected to VBAT2. BSWOUT High indicates VBAT1 is disconnected from VBAT2. This output is valid only in the Active states.
BSWTH	Input	Input for setting automatic battery switch threshold. Normally tied to Battery 2. Tie to ground for manual switching.
C3–C1	Input	Decoder. TTL compatible. C3 is MSB and C1 is LSB.
C4	Input	Test Relay Input – Active Low. 1 = Off. 0 = On.
CAS	Capacitor	Anti-sat pin for capacitor to filter reference voltage when operating in anti-sat region.
DA	Input	Ring-trip negative. Negative input to ring-trip comparator.
DB	Input	Ring-trip positive. Positive input to ring-trip comparator.
\overline{DET}	Output	Switchhook detector. When enabled, a logic Low indicates the selected detector is tripped. The detector is selected by the logic inputs (C3–C1). The output is open-collector with a built-in 15 k Ω pull-up resistor.
E1	Input	Ground-Key Detect Select. E1 = 1 selects the hook switch detector. E1 = 0 selects the ground-key detector. In the Tip Open state, ground key is selected independent of E1.
HPA	Capacitor	High-Pass Filter Capacitor. A(TIP) side of high-pass filter capacitor.
HPB	Capacitor	High-Pass Filter Capacitor. B(RING) side of high-pass filter capacitor.
NC	—	No connect. This pin not internally connected.
OVH	Input	Overhead Control. Logic High enables minimized nonmetering overhead. Logic Low enables 2.2 V metering DC overhead. TTL-compatible.
RD	Resistor	Detector resistor. Detector threshold set and filter pin.
RDC	Resistor	DC feed resistor. Connection point for the DC feed current programming network. The other end of the network connects to the receiver summing node (RSN). Connection point for the DC feed current programming network. The other end of the network connects to RSN. V_{RDC} is negative for normal polarity and positive for reverse polarity.
RFA	—	Resistive feed adjust. Adjust the DC feed resistance gain coefficient, GDC, with external resistor connected to ground.
RINGOUT	Output	Ring Relay Driver. Open-collector driver with emitter internally connected to BGND.
RSN	Input	Receive Summing Node. The metallic current (AC and DC) between A(TIP) and B(RING) is equal to 500 times the current into this pin. The networks that program receive gain, two-wire impedance, and feed current all connect to this node.
RSVD	—	Reserved. These pins are reserved for Legerity use. Make no connection to these pins.
TESTOUT	Output	Test Relay Driver. Open collector driver with emitter internally connected to AGND.
TMG	—	Thermal Management. External resistor connects this pin to VBAT2 to offload power dissipation from SLIC. Functions during normal polarity, Active state.
VBAT1	Battery	Most negative battery supply and substrate connection.
VBAT2	Battery	Battery supply for output power amplifiers. Switched to VBAT1 by BSWEN.
VCC	Power	+5 V power supply.
VTX	Output	Transmit Audio. This output is a 0.5066 unity gain version of the A(TIP) and B(RING) metallic voltage. VTX also sources the two-wire input impedance programming network.
Exposed Pad	Battery	This must be electrically tied to VBAT1.

ABSOLUTE MAXIMUM RATINGS

Storage temperature	−55°C to +150°C
With respect to AGND/DGND:	
V_{CC}	−0.4 V to +7.0 V
V_{BAT1}	
Continuous	+0.4 V to −70 V
10 ms	+0.4 V to −75 V
V_{BAT2} and BSWTH	+0.4 V to V_{BAT1}
BGND	+3 V to −3 V
A(TIP) or B(RING) with respect to BGND:	
Continuous	V_{BAT1} to +1 V
10 ms (f = 0.1 Hz)	−70 V to +5 V
1 μ s (f = 0.1 Hz)	−80 V to +8 V
250 ns (f = 0.1 Hz)	−90 V to +12 V
Current from A(TIP) or B(RING)	\pm 150 mA
TESTOUT/RINGOUT/current	80 mA
TESTOUT/RINGOUT/voltage	BGND to +7 V
TESTOUT/RINGOUT/transient	BGND to +10 V
DA and DB inputs	
Voltage on ring-trip inputs	V_{BAT1} to 0 V
Current on ring-trip inputs	\pm 10 mA
C4–C1, BSWEN, OVH, E1	
Input voltage	−0.4 V to $V_{CC} + 0.4$ V
Maximum power dissipation, continuous*	
$T_A = 70^\circ\text{C}$, No heat sink (see note):	
In 32-pin PLCC package	1.7 W
Thermal data (θ_{JA})	
In 32-pin PLCC package	43°C/W typ
ESD immunity (HBM)	JESD22 Class 1C compliant

* Thermal limiting circuitry on chip will shut down the circuit at a junction temperature of about 165°C. Continuous operation above 145°C junction temperature may degrade device reliability.

Stresses above those listed under Absolute Maximum Ratings may cause permanent device failure. Functionality at or above these limits is not implied. Exposure to Absolute Maximum Ratings for extended periods may affect device reliability.

Package Assembly

Green package devices are assembled with enhanced, environmental compatible lead-free, halogen-free, and antimony-free materials. The leads possess a matte-tin plating which is compatible with conventional board assembly processes or newer lead-free board assembly processes. The peak soldering temperature should not exceed 245°C during printed circuit board

OPERATING RANGES

Commercial (C) Devices

Ambient temperature	−40°C to +85°C*
V_{CC}	4.75 V to 5.25 V
BAT1	−40.5 V to −60 V
BAT2	−20 V to BAT1
AGND/DGND	0 V
BGND with respect to GND	−100 mV to +100 mV
Load resistance on VTX to GND	20 k Ω min

Operating ranges define those limits over which the functionality of the device is guaranteed by production testing.

* Legerity guarantees the performance of this device over commercial (0 to 70°C) and industrial (−40 to 85 °C) temperature ranges by conducting electrical characterization over each range and by conducting a production test with single insertion coupled to periodic sampling. These characterization and test procedures comply with section 4.6.2 of Bellcore TR-TSY-000357 Component Reliability Assurance Requirements for Telecommunications Equipment.

ELECTRICAL CHARACTERISTICS

Description	Test Conditions (See Note 1)	Min	Typ	Max	Unit	Note	
Transmission Performance							
2-wire return loss (See Test Circuit D)	200 Hz to 3.4 kHz	26			dB	4, 6	
Analog output (V_{TX}) impedance			3	20	Ω	4	
Analog output (V_{TX}) offset voltage		-50		+50	mV		
Overload level, 2-wire	Active state	2.5			Vpk	2a, 3	
THD, Total Harmonic Distortion	0 dBm		-64	-50	dB	3	
	+7 dBm		-55	-40			
THD, open loop	0 dBm, $R_{LAC} = 600 \Omega$			-36		4	
Longitudinal Capability (See Test Circuit C)							
Longitudinal to metallic L-T 200 Hz to 1 kHz	Normal polarity	-3*	52		dB	8	
	Normal polarity	0°C to +70°C -2	60				
	Normal polarity	-40°C to +85°C -2	58				
	Reverse polarity	-40°C to +85°C -2	54				
Longitudinal to metallic L-T 1 kHz to 3.4 kHz	Normal polarity	-3	52		dB	8	
	Normal polarity	0°C to +70°C -2	54				
	Normal polarity	-40°C to +85°C -2	54				
	Reverse polarity	-40°C to +85°C -2	54				
Longitudinal signal generation 4-L	200 Hz to 3.4 kHz	40			dB		
Longitudinal current per pin (A or B)	Active state	15	27		mArms	7	
Longitudinal impedance at A or B	0 to 100 Hz		25		Ω /pin	4	
Longitudinal Induction				23	dBrc	4	
Idle Channel Noise							
C-message weighted noise	$R_L = 600 \Omega$		+7	+12	dBrc	4, 8	
Psophometric weighted noise	$R_L = 600 \Omega$		-83	-78	dBmp	8	
Insertion Loss (See Test Circuits A and B)							
Gain, 4- to 2-wire	0 dBm, 1 kHz	0°C to 70°C	-0.15	0	+0.15	dB	
		-40°C to 85°C	-0.20	0	+0.20		
Gain, 2- to 4-wire, 4-to-4-wire	0 dBm, 1 kHz	0°C to 70°C	-6.05	-5.90	-5.75		4
		-40°C to 85°C	-6.10	-5.90	-5.70		
Gain, 4- to 2-wire	Open loop		-0.35		+0.35		4
Gain, 2- to 4-wire, 4- to 4-wire	Open loop		-6.25	-5.90	-5.55		4
Gain over frequency	300 to 3.4 kHz, relative to 1 kHz		-0.10		+0.10		
Gain tracking	+3 dBm to -55 dBm relative to 0 dBm		-0.10		+0.10		
Gain tracking open loop	0 dB to -15 dB		-0.35		+0.35	4	
Group delay	0 dBm, 1 kHz		4		μ s	4, 6	

Note:

* P.G. = Performance Grade

ELECTRICAL CHARACTERISTICS (CONTINUED)

Description		Test Conditions (See Note 1)	Min	Typ	Max	Unit	Note
Line Characteristics							
I _L , Active	Short loop	R _{LDC} = 250 Ω	44.2	48.6	54.0	mA	
	Medium loop	R _{LDC} = 700 Ω	33.4	37.1	40.8		
	Long loop	R _{LDC} = 2 kΩ	17.2	19.2	21.2		
I _L , Active	Short loop	R _{LDC} = 250 Ω	44.2	48.6	54.0	mA	
	Long loop	R _{LDC} = 2 kΩ	16.0	18.0	20.0		
I _L , Accuracy, Standby state	$I_L = \frac{ V_{BAT1} - 3 V}{R_L + 400}$ T _A = 25°C		0.7 I _L	I _L	1.3 I _L		
	Current limited region		18	30			
I _L , Loop current, Disconnect state	R _L = 0				100	μA	
I _L LIM	Active, A and B to GND			95	135	mA	
V _{apparent}				52		V	4
V _{AB} , Open loop voltage	Active, Normal		40.3	41.7			
	Reverse Polarity		39.8	41.7			
	OVH = 0		37	39			
BAT SW hysteresis				1150		mV	
BAT SW threshold (from V _{BAT1} to V _{BAT2})				BAT2 + 8.5		V	
I _A , Leakage, Tip Open state	R _L = 0				100	μA	
I _B , Current, Tip Open state	B to GND		18	30	56	mA	
V _A , Active	RA to BAT1 = 7 kΩ, RB to GND = 100 Ω		-7.5	-5		V	4
Power Supply Rejection Ratio (Vripple = 100 mVrms), Active Normal State							
V _{CC}	50 Hz to 3.4 kHz		30	45		dB	3
V _{BAT1}	50 Hz to 3.4 kHz		28	50			4
V _{BAT2}	50 Hz to 3.4 kHz		35	50			4
V _{BAT1} , Open loop, R _{LAC} = 600 Ω (Anti-sat region)	50 Hz		8	14			
	100 Hz		15	22			
	200 Hz		20	29			
	500 Hz to 3.4 kHz		28	40			
Effective internal resistance	CAS pin to GND		85	170	255	kΩ	4
Device Power Dissipation							
Open loop, Disconnect state				35	70	mW	9
Open loop, Standby state				50	85		
Open loop, Active state	OVH = 1			150	250		
Open loop, Active state	OVH = 0			550	620		
Off hook, Standby state	R _L = 600 Ω			1000	1300		
Off hook, Active state	R _L = 250 Ω			880	1200		
	R _L = 700 Ω			800	1000		
Supply Currents, Battery							
I _{CC} , Open Loop V _{CC} supply current	Disconnect state			2.5	4.5	mA	
	Standby state			3.0	4.5		
	Active state			6.3	9.5		
I _{BAT1} , Open Loop V _{BAT1} supply current	Disconnect state			0.5	1.0	mA	
	Standby state			0.7	1.5		
	Active state			2.8	4.8		

ELECTRICAL CHARACTERISTICS (CONTINUED)

Description	Test Conditions (See Note 1)	Min	Typ	Max	Unit	Note
RFI Rejection						
RFI rejection	100 kHz to 30 MHz (See Figure E)			0.7	mVrms	4
Logic Inputs (C4–C1, E1, BSWEN, OVH [-5, -6 only])						
V _{IH} , Input High voltage C3 C1, C2, C4, BSWEN, OVH, E1		2.5			V	
		2.0				
V _{IL} , Input Low voltage				0.8		
I _{IH} , Input High current C4–C1, OVH, E1		-75		40	μA	
I _{IH} , Input High current, BSWEN		-75		1200		
I _{IL} , Input Low current, except C1		-400				
I _{IL} , Input Low current, C1		-600	-300			
Logic Output (DET, BSWOUT)						
V _{OL} , Output Low voltage	I _{OUT} = 0.3 mA			0.40	V	
V _{OH} , Output High voltage	I _{OUT} = -0.05 mA	2.4				
Ring-Trip Comparator Input (DA, DB)						
Bias current		-500	-50		nA	
Offset voltage	Source resistance = 2 MΩ	-50	0	+50	mV	5
Loop Detector						
I _T , Loop-detect threshold tolerance	Active state, Off-hook to On-hook R _D = 35.4 kΩ, I _T = 368/R _D	-15		+15	%	
	On-hook to Off-hook R _D = 35.4 kΩ, I _T = 414/R _D	-20		+20		
	Standby state, Off-hook to On-hook R _D = 35.4 kΩ, I _T = 425/R _D	-15		+15		
	On-hook to Off-hook R _D = 35.4 kΩ, I _T = 471/R _D	-20		+20		
Loop-detect threshold hysteresis	Active state		1.3		mA	4
	Standby state					
IGK, GND key-detector threshold	R _L from BX to GND Active, Standby, and Tip Open states	5	9	13		
Relay Driver Output (RINGOUT/TESTOUT)						
On voltage	I _{OL} = 40 mA		+0.3	+0.7	V	
Off leakage	V _{OH} = +5 V			100	μA	
Zener breakover	I _Z = 100 μA	6	7.5		V	
Zener On voltage	I _Z = 40 mA		7.9	10		

RELAY DRIVER SCHEMATICS

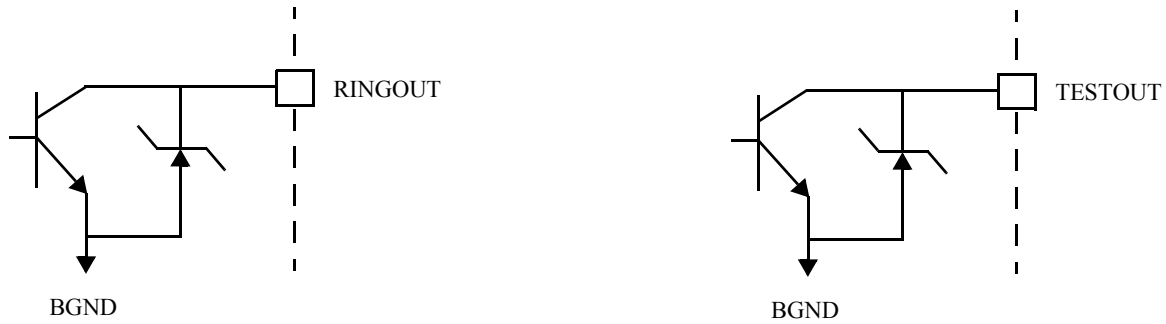

Notes:

1. Unless otherwise specified, test conditions are $V_{CC} = +5\text{ V}$, $BAT1 = -50\text{ V}$, $BAT2 = -34\text{ V}$, $R_L = 600\ \Omega$, $R_{DC1} = R_{DC2} = 5.833\text{ k}\Omega$, $R_{TMG} = 570\ \Omega$, $R_D = 35.4\text{ k}\Omega$, $R_{FA} = 0\ \Omega$, no fuse resistors, $C_{HP} = 0.22\ \mu\text{F}$, $C_{DC} = 0.5\ \mu\text{F}$, $C_{CAS} = 0.33\ \mu\text{F}$, $C_{VBAT12} = 220\text{ nF}$, $D_1 = D_2 = 1\text{N}400\text{x}$, $OVH = 1$, two-wire AC input impedance is a $600\ \Omega$ resistance synthesized by the programming network shown below.

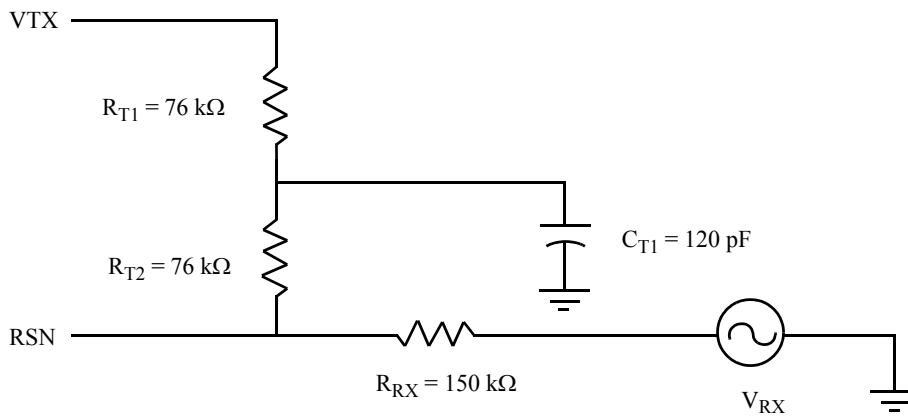

2. a. Overload level exists when $THD = 1\%$.
b. Overload level exists when $THD = 1.5\%$.
3. This parameter is tested at 1 kHz in production. Performance at other frequencies is guaranteed by characterization.
4. Not tested in production. This parameter is guaranteed by characterization or correlation to other tests.
5. Tested with $0\ \Omega$ source impedance. $2\text{ M}\Omega$ is specified for system design only.
6. Group delay can be greatly reduced by using a Z_T network such as that shown in Note 1 above. The network reduces the group delay to less than $2\ \mu\text{s}$ and increases 2WRL . The effect of group delay on linecard performance also may be compensated for by synthesizing complex impedance with the $DSLAC^{\text{TM}}$ or $QSLAC^{\text{TM}}$ device.
7. Minimum current level is guaranteed not to cause a false Loop Detect. The SLIC must be functional in this condition.
8. Four-wire performance is $5\text{--}9\text{ dB}$ better than the specified two-wire values.
9. Open loop, Active state, Metering mode power dissipation may be reduced from a typical of 550 mW to a typical of 150 mW by connecting the \overline{DET} pin to the OVH pin. This connection will force the SLIC into the nonmetering mode while on hook. With this connection, a metering signal sent after the SLIC goes on hook may be distorted on the 2W line because the SLIC is forced into the nonmetering mode. To eliminate this distortion, a delay can be added between the time the SLIC goes on hook and the time the SLIC switches to nonmetering mode by using an RC circuit for the \overline{DET} pin to OVH pin connection.

Table 1. SLIC Decoding

State	C3 C2 C1	2-Wire Status	$\overline{\text{DET}}$ Output	
			E1 = 1	E1 = 0
0	0 0 0	Standby, Reverse Polarity	Loop detector	GK
1	0 0 1	Reserved	X	X
2	0 1 0	Active, Reverse Polarity	Loop detector	GK
3	0 1 1	Tip Open	GK or loop detector	GK
4	1 0 0	Disconnect	Ring trip	Ring trip
5	1 0 1	Ringing	Ring trip	Ring trip
6	1 1 0	Active, Normal	Loop detector	GK
7	1 1 1	Standby, Normal	Loop detector	GK

Table 2. User-Programmable Components

$Z_T = 253(Z_{2WIN} - 2R_F)$	<p>Z_T is connected between the VTX and RSN pins. The fuse resistors are R_F, and Z_{2WIN} is the desired two-wire AC input impedance. When computing Z_T, the internal current amplifier pole and any external stray capacitance between VTX and RSN must be taken into account. The internal amplifier pole is:</p> $\frac{22 \text{ kHz} \cdot R_{LAC}}{600 \Omega \pm 10\%}$
$Z_{RX} = \frac{Z_L}{G_{42L}} \cdot \frac{500(Z_T)}{Z_T + 253(Z_L + 2R_F)}$	<p>Z_{RX} is connected from VRX to RSN. Z_T is defined above, and G_{42L} is the desired receive gain. Z_L is the 2-wire load impedance.</p>
$I_{LIMIT} = \frac{625(GFA)}{R_{DC1} + R_{DC2}}$ $C_{DC} = 1.5 \text{ ms} \cdot \frac{R_{DC1} + R_{DC2}}{R_{DC1} \cdot R_{DC2}}$ $GFA = 0.99 \cdot \frac{(RFA + 30.1 \text{ k}\Omega)}{(RFA + 32 \text{ k}\Omega)}$ $RCL = 1.4 \cdot (R_{DC1} + R_{DC2}) \cdot \frac{(RFA + 60 \text{ k}\Omega)}{(RFA + 100 \text{ k}\Omega)}$	<p>R_{DC1}, R_{DC2}, and C_{DC} form the network connected to the R_{DC} pin. R_{DC1} and R_{DC2} are approximately equal. I_{LIMIT} is the desired loop current in the constant-current region.</p>
$R_D = \frac{365}{I_T}, \quad C_D = \frac{0.5 \text{ ms}}{R_D}$	<p>R_D and C_D form the network connected from R_D to AGND/DGND and I_T is the threshold current between on hook and off hook in the Active state.</p>
$C_{CAS} = \frac{1}{3.4 \cdot 10^5 \pi f_c}$	<p>C_{CAS} is the regulator filter capacitor and f_c is the desired filter cutoff frequency.</p>
$I_{Standby} = \frac{ V_{BAT1} - 3 \text{ V}}{400 \Omega + R_L}$	<p>Standby loop current (resistive region).</p>
$C_{BSWEN} = 5 \mu\text{hos} \cdot T_D(\text{ms})$	<p>C_{BSWEN} is connected from BSWEN to GND for automatic switching. T_D is the delay in switching from BAT1 to BAT2. The delay from BAT2 to BAT1 is about 0.1 T_D.</p>

Table 2. User-Programmable Components (continued)

$R_{FEED} = 2 \cdot R_{FUSE} + \left(\frac{R_{DC1} + R_{DC2}}{GDC} \right)$ $GDC = 47.9 \left(\frac{40 \text{ k}\Omega + RFA}{120 \text{ k}\Omega + RFA} \right)$	<p>The DC feed resistance can be adjusted with a resistance (RFA) from the RFA pin to ground.</p>
Thermal Management Equations (Active, Normal, and Reverse Polarity States)	
$R_{TMG} \geq \frac{ V_{BAT2} - 6 \text{ V}}{I_{LOOPmax}} \quad (OVH = 1)$ $R_{TMG} \geq \frac{ V_{BAT2} - 7.5 \text{ V}}{I_{LOOPmax}} \quad (OVH = 0)$	<p>R_{TMG} is connected from TMG to VBAT2 and is used to limit power dissipation within the SLIC in Active states only.</p>
$P_{RTMG} = \frac{(V_{BAT2} - 6 \text{ V} - (I_L \cdot R_L))^2 (R_{TMG})}{(R_{TMG} + 40)^2}$ <p>(OVH = 1)</p> $P_{RTMG} = \frac{(V_{BAT2} - 7.5 \text{ V} - (I_L \cdot R_L))^2 (R_{TMG})}{(R_{TMG} + 40)^2}$ <p>(OVH = 0)</p>	<p>Power dissipated in the thermal management resistor, R_{TMG}, during the Active states.</p>
$P_{SLIC} = (V_{BAT2} \cdot I_L) - P_{RTMG} - R_L \cdot (I_L)^2 + 0.22 \text{ W}$	<p>Power dissipated in the SLIC while in the Active states.</p>

DC FEED CHARACTERISTICS

$$R_{DC} = R_{DC1} + R_{DC2} = 11.67 \text{ k}\Omega,$$

$$R_{FA} = 0 \Omega$$

No fuse resistors

$$OVH = 1$$

$$BAT1 = -50 \text{ V}$$

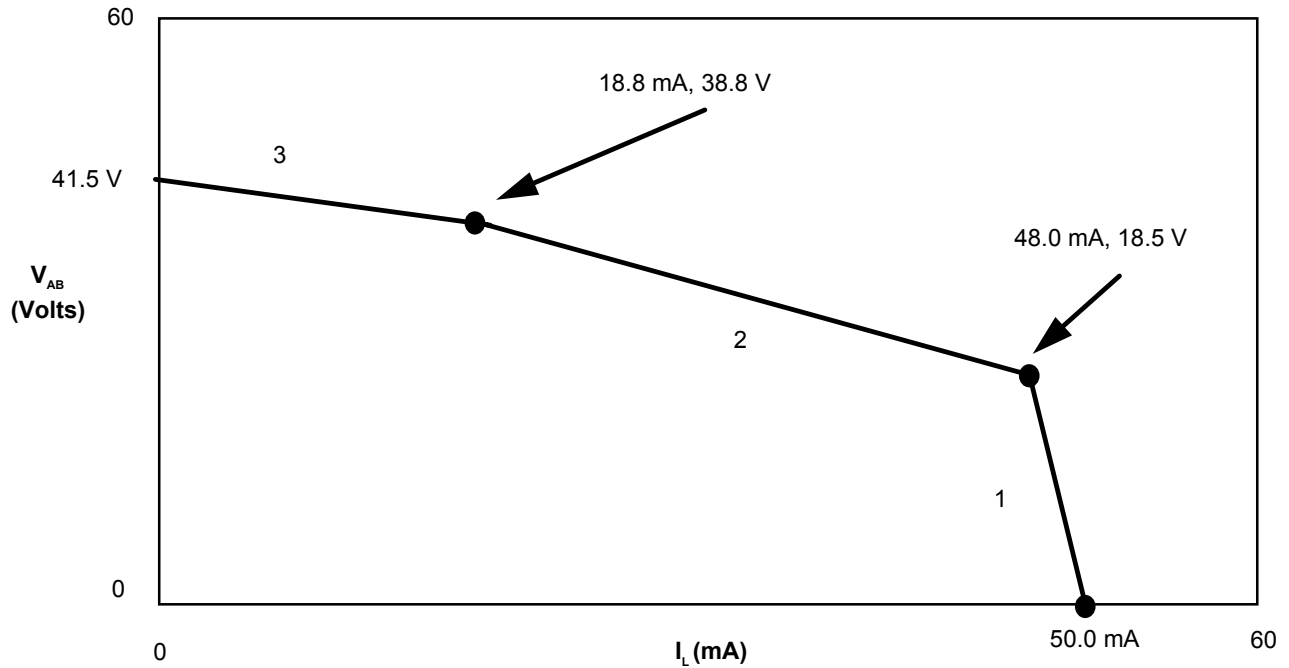

Notes:

Graph is for illustration only.

$$1. V_{AB} = I_{LIMIT} \cdot R_{CL} - I_L \cdot R_{CL}$$

$$2. V_{AB} = 52 \text{ V} - I_L \left(\frac{R_{DC}}{GDC} \right)$$

$$3a. V_{AB} = 0.8|V_{BAT1}| + 2.2 - I_L \left(\frac{R_{DC}}{5 \cdot GDC} \right), OVH = 1$$

$$3b. V_{AB} = 0.8|V_{BAT1}| - 1.0 - I_L \left(\frac{R_{DC}}{5 \cdot GDC} \right), OVH = 0$$

a. Load Line (Typical)

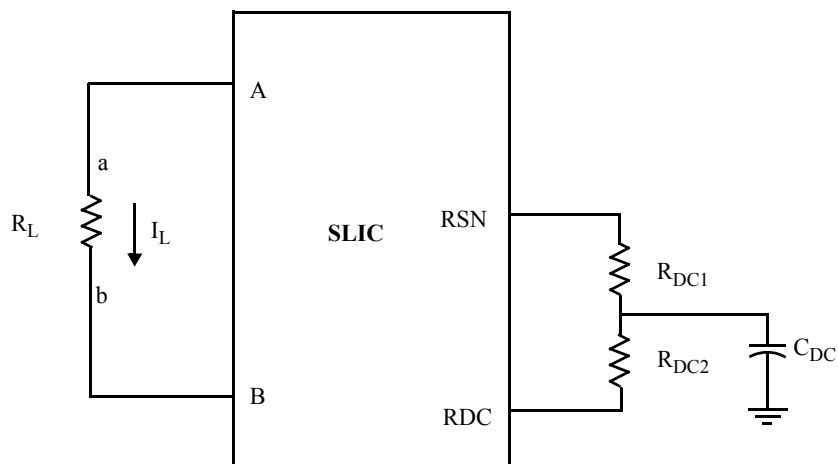

Feed current programmed by R_{DC1} and R_{DC2}

b. Feed Programming

Figure 1. DC Feed Characteristics

TEST CIRCUITS

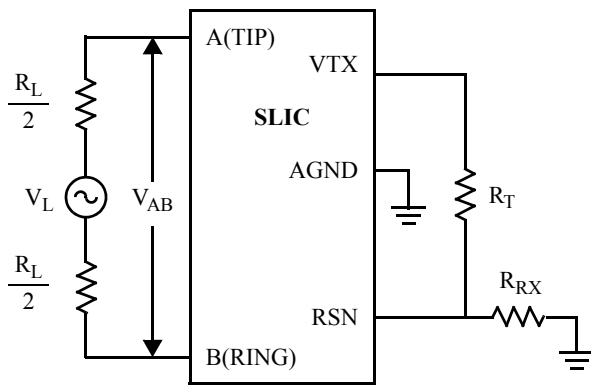

$$I_{L2-4} = -20 \log (V_{TX} / V_{AB})$$

A. Two- to Four-Wire Insertion Loss

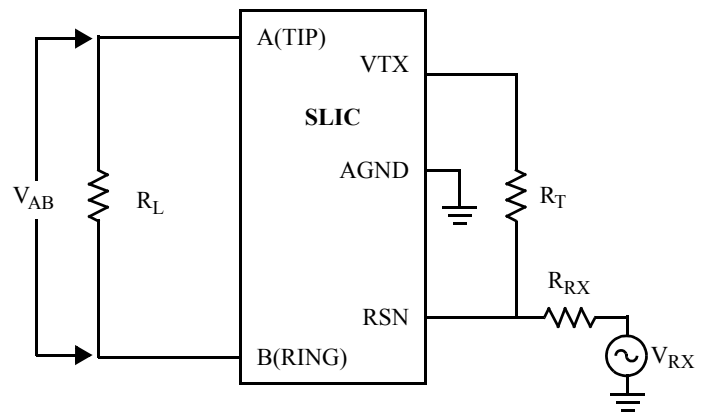

$$I_{L4-2} = -20 \log (V_{AB} / V_{RX})$$

B. Four- to Two-Wire Insertion Loss

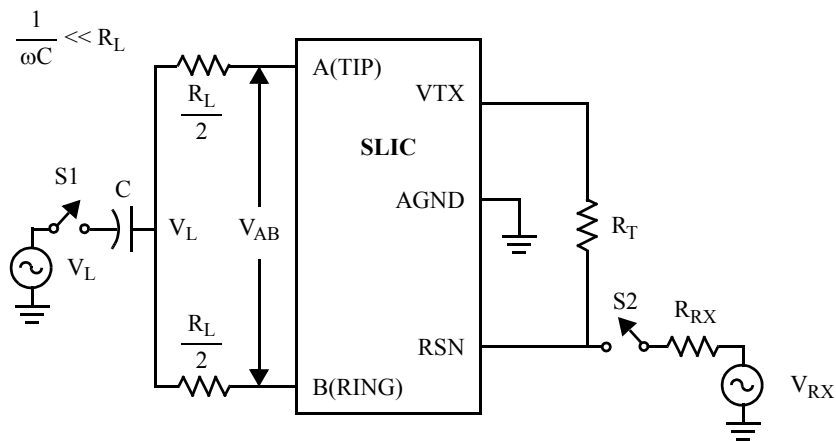

S2 Open, S1 Closed

L-T Long. Bal. = $20 \log (V_{AB} / V_L)$

L-4 Long. Bal. = $20 \log (V_{TX} / V_L)$

S2 Closed, S1 Open

4-L Long. Sig. Gen. = $20 \log (V_L / V_{RX})$

C. Longitudinal Balance

TEST CIRCUITS (continued)

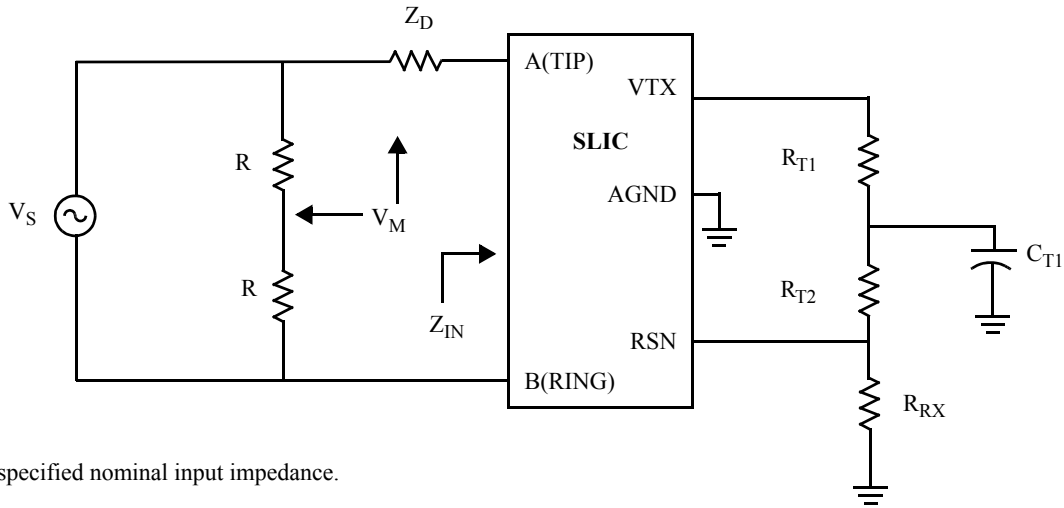

Z_D is the specified nominal input impedance.

$$\text{Return loss} = -20 \log (2 V_M / V_S)$$

D. Two-Wire Return Loss Test Circuit

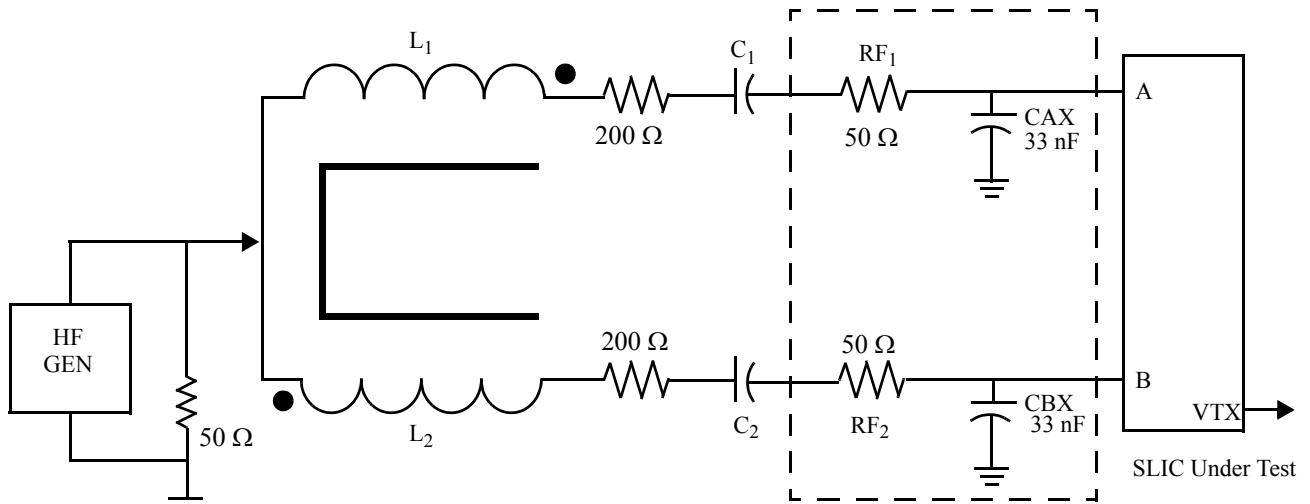

1.5 Vrms
80% Amplitude
Modulated
100 kHz to 30 MHz

E. RFI Test Circuit

TEST CIRCUITS (continued)

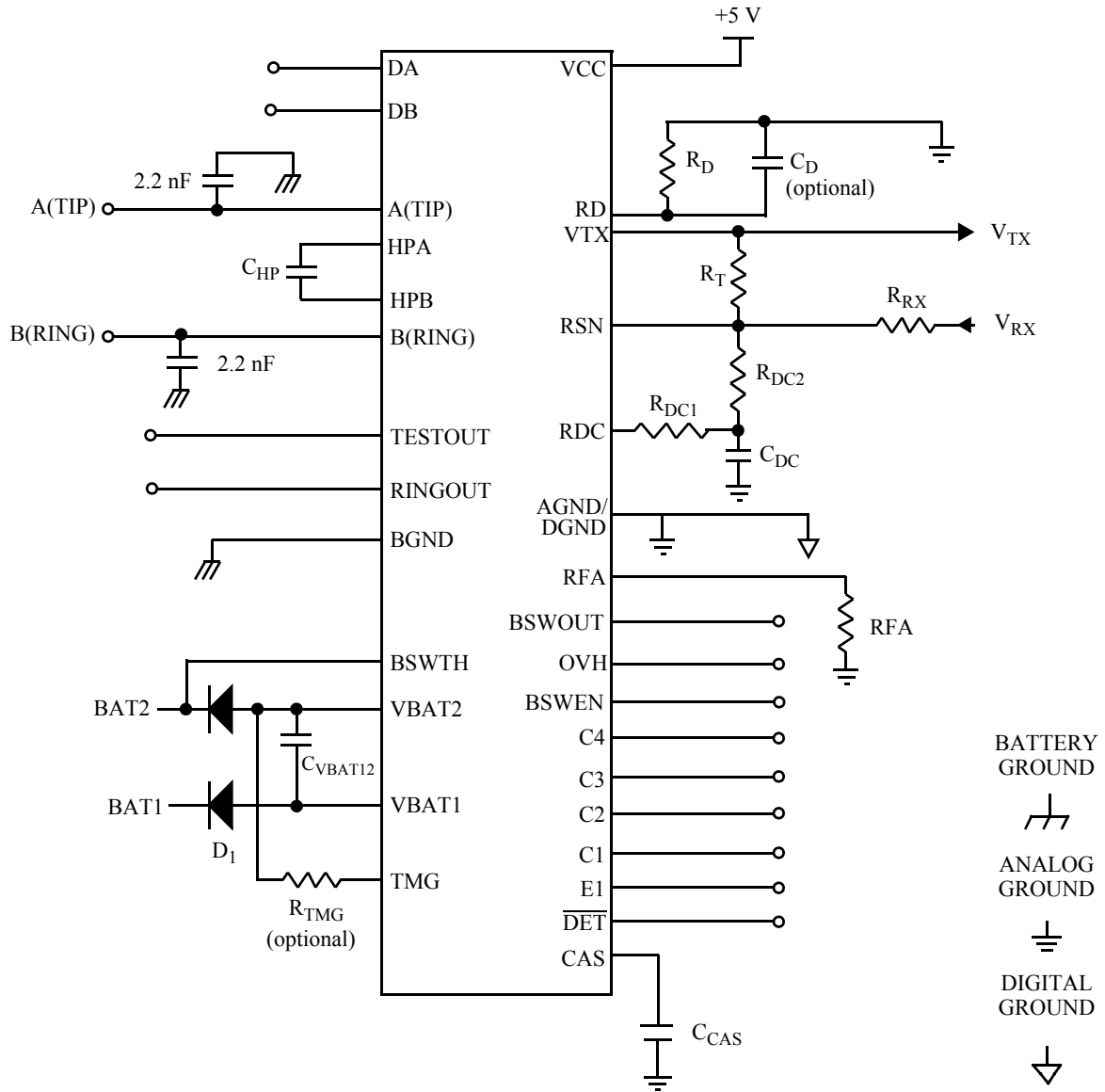

F. Le79489 Test Circuit

PHYSICAL DIMENSIONS

32-Pin PLCC

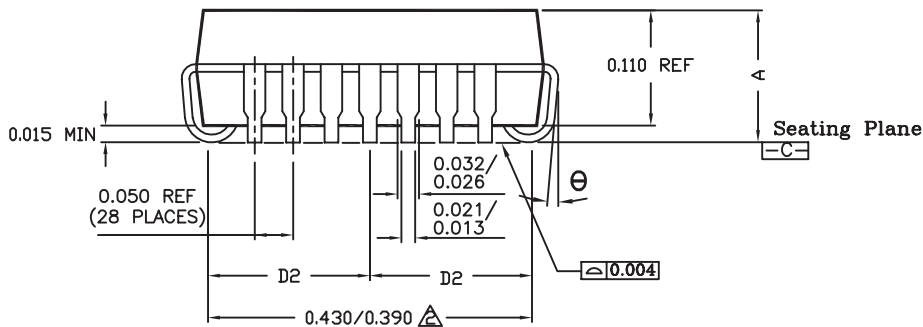
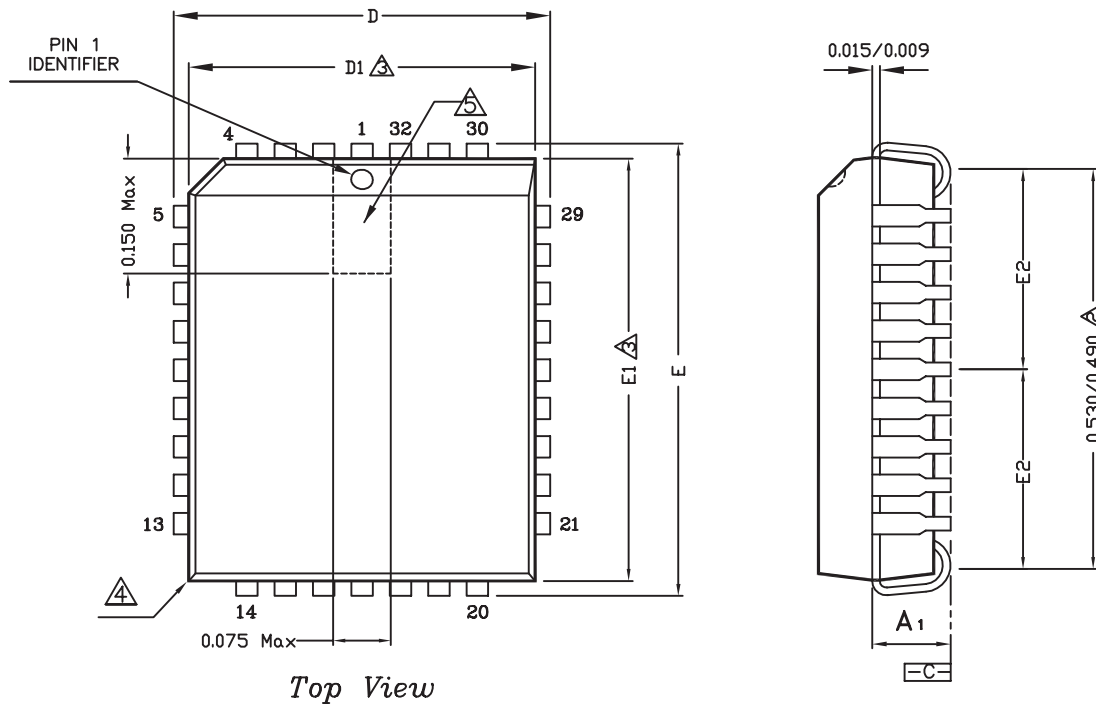

NOTE :

1. DIMENSIONING AND TOLERANCING CONFORM TO ASME Y14,5M-1994.
- △ TO BE MEASURED AT SEATING PLANE $\equiv C \equiv$ CONTACT POINT.
- △ DIMENSIONS D1 AND E1 DO NOT INCLUDE MOLD PROTUSION. ALLOWABLE MOLD PROTUSION IS 0.010 IN PER SIDE. DIMENSIONS D, AND E, INCLUDE MOLD MISMATCH AND DETERMINED AT THE PARTING LINE; THAT IS D1 AND E1 ARE MEASURED AT THE EXTREME MATERIAL CONDITION AT THE UPPER OR LOWER PARTING LINE.
- △ EXACT SHAPE OF THIS FEATURE IS OPTIONAL.
- △ DETAILS OF PIN 1 IDENTIFIER ARE OPTIONAL BUT MUST BE LOCATED WITHIN THE ZONE INDICATED.
6. SUM OF DAM BAR PROTUSIONS TO BE 0.007 MAX PER LEAD.
7. CONTROLLING DIMENSION : INCH.
8. REFERENCE DOCUMENT : JEDEC MS-016

Symbol	Dimension in inch		
	Min	Nom	Max
A	0.125	—	0.140
A1	0.075	0.090	0.095
D	0.485	0.490	0.495
D1	0.447	0.450	0.453
D2	0.205 REF		
E	0.585	0.590	0.595
E1	0.547	0.550	0.553
E2	0.255 REF		
θ	0°	—	10°

Note:

Packages may have mold tooling markings on the surface. These markings have no impact on the form, fit or function of the device. Markings will vary with the mold tool used in manufacturing.

REVISION SUMMARY

Revision C to Revision D

- In the Electrical Characteristics table on page 8, some information was changed in the Test Conditions column in the Loop Detector section and the “Loop-detect threshold hysteresis” row was added to this section.

Revision D to Revision E

- The physical dimensions (PL032) were added to the Physical Dimensions section.
- Updated the Pin Description table to correct inconsistencies.

Revision E to Revision F

- Updated OPN (Ordering Part Number) throughout document.
- Absolute Maximum Ratings: Notes updated to standard.
- Operating Ranges: Temperature statement updated to standard.
- Updated "Sales Office Listing."
- Updated physical dimension drawings.

Revision F1 to G1

- Removed non-green OPNs from Ordering Information.
- Removed all QFN package information throughout data sheet.
- In *Electrical Characteristics*, removed specifications for polarity grade options, 1 and 4 - 6

Revision G1 to G2

- Added notes to Ordering Information on page 2.

The contents of this document are provided in connection with Legerity, Inc. products. Legerity makes no representations or warranties with respect to the accuracy or completeness of the contents of this publication and reserves the right to make changes to specifications and product descriptions at any time without notice. No license, whether express, implied, arising by estoppel or otherwise, to any intellectual property rights is granted by this publication. Except as set forth in Legerity's Standard Terms and Conditions of Sale, Legerity assumes no liability whatsoever, and disclaims any express or implied warranty, relating to its products including, but not limited to, the implied warranty of merchantability, fitness for a particular purpose, or infringement of any intellectual property right. Legerity's products are not designed, intended, authorized or warranted for use as components in systems intended for surgical implant into the body, or in other applications intended to support or sustain life, or in any other application in which the failure of Legerity's product could create a situation where personal injury, death, or severe property or environmental damage may occur. Legerity reserves the right to discontinue or make changes to its products at any time without notice.

© 2007 Legerity, Inc.
All rights reserved.

Trademarks

Legerity, the Legerity logo and combinations thereof are registered trademarks, and BatteryDirect, ISLIC, ISLAC, PhonePort, QLSLAC, VoiceEdge, VoicePath, VoicePort, and WinSLAC are trademarks of Legerity, Inc.

Other product names and marks used within this document are for identification purposes only and may be registered trademarks or trademarks of their respective companies.



4509 Freidrich Lane
Austin, Texas 78744-1812

Telephone: (512) 228-5400
Fax: (512) 228-5508
North America Toll Free: (800) 432-4009

To find the Legerity Sales Office nearest you, visit our website at:

<http://www.legerity.com/sales>

or email:

sales@legerity.com

To download or order data sheets, application notes, or evaluation tools, go to:

www.legerity.com/support