

Tantalum Surface Mount Capacitors

Fused



One world. One KEMET.

Electronic Components
KEMET
CHARGED.®

Table of Contents	Page
Why Choose KEMET	3
T496 Series Fused MnO₂	5
T496 Series Fused Commercial Off-The-Shelf (COTS) MnO₂ and DLA (DSCC) Drawing 04053	17
Packaging Information.....	31
KEMET Corporation Sales Offices	36
Disclaimer	37

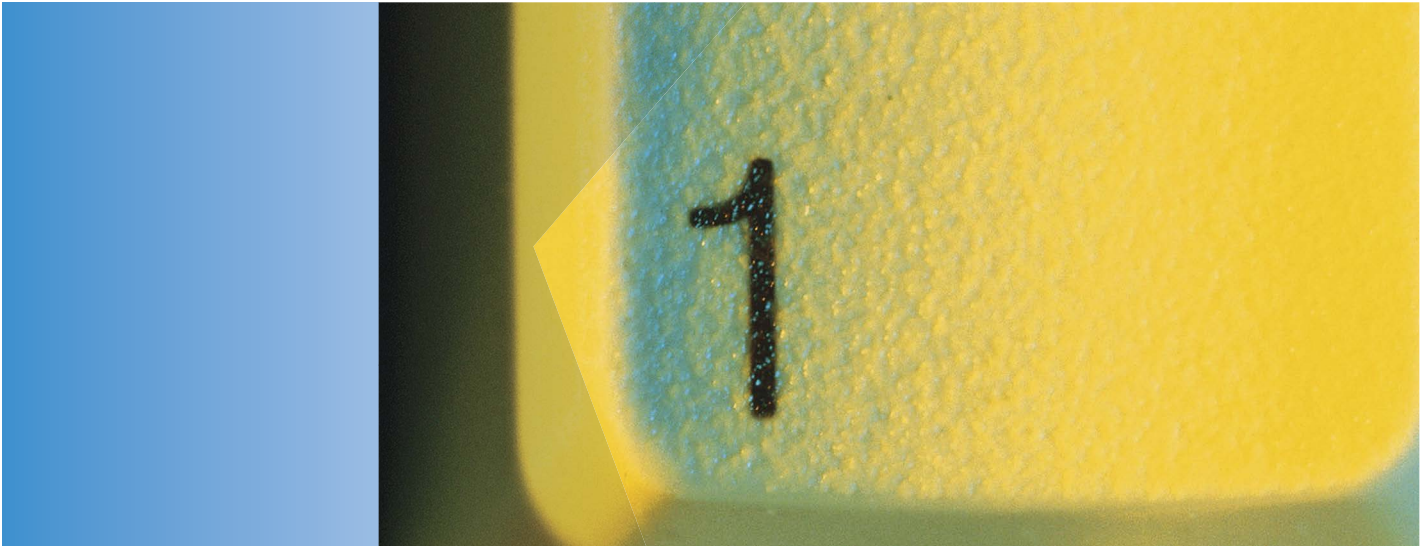

One world. One source. One KEMET.

When you partner with KEMET, our entire global organization provides you with the coordinated service you need. No bouncing from supplier to supplier. No endless phone calls and web browsing. We're your single, integrated source for electronic component solutions worldwide.

Less hassles. More solutions.

Our commitment to product quality and on-time delivery has helped customers succeed for over 90 years. There's a reason KEMET components can be found in defense and aerospace equipment. Our reputation is built on a history of consistency, reliability and service.

The "Easy-to-Buy-From" company.

KEMET offers a level of responsiveness that far surpasses any other supplier. Our passion for customer service is evident throughout our global sales organization, which offers localized support bolstered by our worldwide logistics capabilities. Whether you need rush samples, technical assistance, in-person consultation, accelerated custom design, design collaboration or prototype services, we have a solution.



Made for you.

When you need custom products delivered on a tight schedule, you can trust KEMET. Get direct design consultation from global experts, who help you get the job done on time and within budget.

Working for a better world.

KEMET is dedicated to economically, environmentally and socially sustainable development. We've adopted the Electronic Industry Code of Conduct (EICC) to address all aspects of corporate responsibility. Our manufacturing facilities have won numerous environmental excellence awards and recognitions, and our supply chain is certified. We believe doing the right thing is in everyone's interest.

About KEMET.

KEMET Corporation is a leading global supplier of electronic components. We offer our customers the broadest selection of capacitor technologies in the industry across multiple dielectrics, along with an expanding range of electromechanical devices, and electromagnetic compatibility solutions. Our vision is to be the preferred supplier of electronic component solutions for customers demanding the highest standards of quality, delivery and service.

Overview

The T496 Series of tantalum chip capacitors offers a "fail safe" design. The built-in fuse element offers excellent protection from damaging short circuit conditions in applications where damaging high fault currents exist. Protection from costly circuit damage due

to reversed installation is offered with this device. This series is classified as MSL (Moisture Sensitivity Level) 1 under J STD 020: unlimited floor life time at $\leq 30^{\circ}\text{C}/85\% \text{ RH}$.

Benefits

- Meets or exceeds EIA Standard 535BAAC
- Approved to DSCC drawing 04053
- Patented fuse assembly
- Optional gold-plated terminations
- Built-in fuse protects against short circuit mode
- 100% surge current test on C, D, and X sizes
- Halogen-free epoxy
- Capacitance values of 0.15 μF to 330 μF
- Tolerances of $\pm 10\%$ and $\pm 20\%$
- Voltage rating of 4 – 50 VDC
- Fuse activation, 25°C: within 1 second at fault currents of 4 amps and higher
- Continuous current capability: 0.75 amps
- Post actuation resistance, 25°C: 10 M Ω , minimum
- Test tabs on side of case bypass the capacitor element to allow direct testing of the fuse assembly
- RoHS Compliant and lead-free terminations
- Operating temperature range of -55°C to $+125^{\circ}\text{C}$

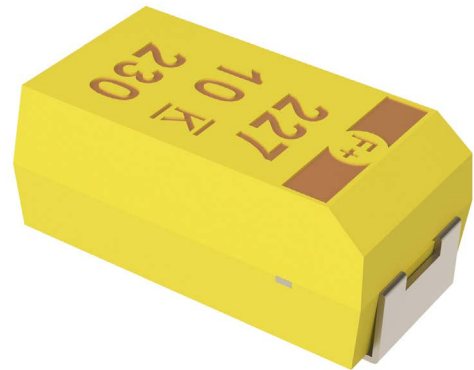

Applications

Typical applications include decoupling and filtering in computing and telecommunications end applications, such as high-end servers requiring built-in fuse capability.

Environmental Compliance

RoHS Compliant (6/6) according to Directive 2002/95/EC when ordered with 100% Sn solder.



RoHS Compliant

SPICE

For a detailed analysis of specific part numbers, please visit www.kemet.com for a free download of KEMET's SPICE software. The KEMET SPICE program is freeware intended to aid design engineers in analyzing the performance of these capacitors over frequency, temperature, ripple, and DC bias conditions.

Ordering Information

T	496	X	227	M	010	A	T	E500	
Capacitor Class	Series	Case Size	Capacitance Code (pF)	Capacitance Tolerance	Voltage	Failure Rate/Design	Lead Material	ESR	Packaging (C-Spec)
T = Tantalum	Fail Safe	B, C, D, X	First two digits represent significant figures. Third digit specifies number of zeros.	K = ±10% M = ±20%	004 = 4 V 006 = 6.3 V 010 = 10 V 016 = 16 V	A = N/A	T = 100% Matte Tin (Sn) Plated H = Standard Solder Coated (SnPb 5% Pb minimum)	E = ESR Last three digits specify ESR in mΩ (500 = 500 mΩ)	Blank = 7" Reel 7280 = 13" Reel

Performance Characteristics

Item	Performance Characteristics
Operating Temperature	-55°C to 125°C
Rated Capacitance Range	0.15 – 477 μF @ 120 Hz/25°C
Capacitance Tolerance	K Tolerance (10%), M Tolerance (20%)
Rated Voltage Range	4 – 50 V
DF (120 Hz)	Refer to Part Number Electrical Specification Table
ESR (100 kHz)	Refer to Part Number Electrical Specification Table
Leakage Current	≤ 0.01 CV (μA) at rated voltage after 5 minutes

Qualification

Test	Condition	Characteristics				
Endurance	85°C @ rated voltage, 2,000 hours 125°C @ 2/3 rated voltage, 2,000 hours	Δ C/C	Within ±10% of initial value			
		DF	Within initial limits			
		DCL	Within 1.25 x initial limit			
		ESR	Within initial limits			
Storage Life	125°C @ 0 volts, 2,000 hours	Δ C/C	Within ±10% of initial value			
		DF	Within initial limits			
		DCL	Within 1.25 x initial limit			
		ESR	Within initial limits			
Thermal Shock	MIL-STD-202, Method 107, Condition B, mounted, -55°C to 125°C, 1,000 cycles	Δ C/C	Within ±5% of initial value			
		DF	Within initial limits			
		DCL	Within 1.25 x initial limit			
		ESR	Within initial limits			
Temperature Stability	Extreme temperature exposure at a succession of continuous steps at +25°C, -55°C, +25°C, +85°C, +125°C, +25°C		+25°C	-55°C	+85°C	+125°C
		Δ C/C	IL*	±10%	±10%	±20%
		DF	IL	IL	1.5 x IL	1.5 x IL
		DCL	IL	n/a	10 x IL	12 x IL
Surge Voltage	85°C, 1.32 x rated voltage 1,000 cycles (125°C, 1.2 x rated voltage)	Δ C/C	Within ±5% of initial value			
		DF	Within initial limits			
		DCL	Within initial limits			
		ESR	Within initial limits			
Mechanical Shock/Vibration	MIL-STD-202, Method 213, Condition I, 100 G Peak MIL-STD-202, Method 204, Condition D, 10 Hz to 2,000 Hz, 20 G peak	Δ C/C	Within ±10% of initial value			
		DF	Within initial limits			
		DCL	Within initial limits			

*IL = Initial limit

Certification

DSCC Drawing 04053

Electrical Characteristics

ESR vs. Frequency

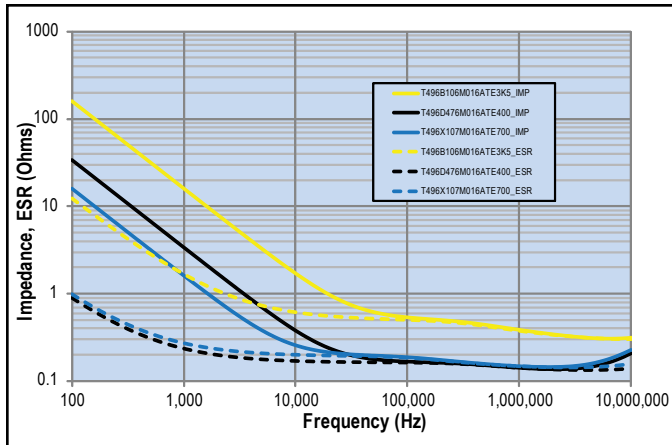

Capacitance vs. Frequency

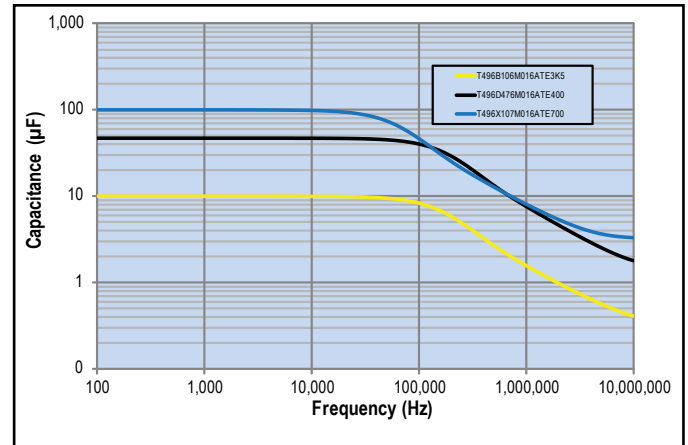

Dimensions – Millimeters (Inches)

Metric will govern

CATHODE (-) END VIEW

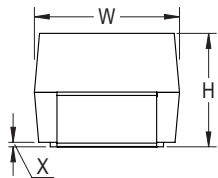

SIDE VIEW



ANODE (+) END VIEW

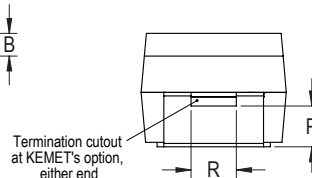

BOTTOM VIEW

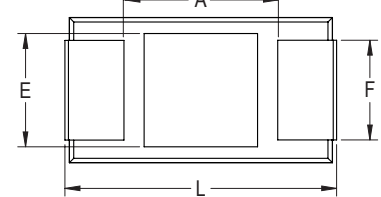

Case Size		Component												
KEMET	EIA	L*	W*	H*	F* ±0.1 ±(.004)	S* ±0.3 ±(.012)	B* ±0.15 (Ref) ±.006	X (Ref)	P (Ref)	R (Ref)	T (Ref)	A (Min)	G (Ref)	E (Ref)
B	3528-21	3.5 ±0.2 (0.138 ±0.008)	2.8 ±0.2 (0.110 ±0.008)	1.9 ±0.2 (0.075 ±0.008)	2.2 (.087)	0.8 (.031)	0.4 (.016)	0.10 ±0.10 (0.004 ±0.004)	0.5 (0.020)	1.0 (0.039)	0.13 (0.005)	1.1 (0.043)	1.8 (0.071)	2.2 (0.087)
C	6032-28	6.0 ±0.3 (0.236 ±0.03)	3.2 ±0.3 (0.126 ±0.012)	2.5 ±0.3 (0.098 ±0.012)	2.2 (.087)	1.3 (.051)	0.5 (.020)	0.10 ±0.10 (0.004 ±0.004)	0.9 (0.035)	1.0 (0.039)	0.13 (0.005)	2.5 (.098)	2.8 (0.110)	2.4 (0.094)
D	7343-31	7.3 ±0.3 (0.287 ±0.012)	4.3 ±0.3 (0.169 ±0.012)	2.8 ±0.3 (0.110 ±0.012)	2.4 (.094)	1.3 (.051)	0.5 (.020)	0.10 ±0.10 (0.004 ±0.004)	0.9 (0.035)	1.0 (0.039)	0.13 (0.005)	3.8 (0.150)	3.5 (0.138)	3.5 (0.138)
X	7343-43	7.3 ±0.3 (0.287 ±0.012)	4.0 ±0.3 (0.169 ±0.012)	4.0 ±0.3 (0.157 ±0.012)	2.4 (.094)	1.3 (.051)	0.5 (.020)	0.10 ±0.10 (0.004 ±0.004)	1.7 (0.067)	1.0 (0.039)	0.13 (0.005)	3.8 (0.150)	3.5 (0.138)	3.5 (0.138)

Notes: (Ref) – Dimensions provided for reference only. No dimensions provided for B, P or R because low profile cases do not have a bevel or a notch.

* MIL-PRF-55365/8 specified dimensions

Table 1 – Ratings & Part Number Reference

Rated Voltage	Rated Cap	Case Code/ Case Size	KEMET Part Number	DC Leakage	DF	ESR	Maximum Allowable Ripple Current			Maximum Operating Temp	MSL
							mA @ +25°C 100 kHz	mA @ +85°C 100 kHz	mA @ +125°C 100 kHz		
VDC @ 85°C	µF	KEMET/EIA	(See below for part options)	µA @ +20°C Max/5 Min	% @ +20°C 120 Hz % Max	mΩ @ +20°C 100 kHz Max	mA @ +25°C 100 kHz	mA @ +85°C 100 kHz	mA @ +125°C 100 kHz	°C	Reflow Temp ≤ 260°C
4	68	C/6032-28	T496C686(1)004A(2)E1K6	2.7	6.0	1600	262	236	105	125	1
4	68	C/6032-28	T496C686(1)004A(2)E400	2.7	6.0	400	524	472	210	125	1
4	100	C/6032-28	T496C107(1)004A(2)E1K2	4.0	8.0	1200	303	273	121	125	1
4	150	D/7343-31	T496D157(1)004A(2)E800	6.0	8.0	800	433	390	173	125	1
4	150	C/6032-28	T496C157(1)004A(2)E1K2	6.0	8.0	1200	303	273	121	125	1
4	220	D/7343-31	T496D227(1)004A(2)E700	8.8	8.0	700	463	417	185	125	1
4	220	D/7343-31	T496D227(1)004A(2)E400	8.8	8.0	400	612	551	245	125	1
4	330	D/7343-31	T496D337(1)004A(2)E700	13.2	8.0	700	463	417	185	125	1
4	330	D/7343-31	T496D337(1)004A(2)E400	13.2	8.0	400	612	551	245	125	1
4	330	X/7343-43	T496X337(1)004A(2)E700	13.2	8.0	700	486	437	194	125	1
4	470	X/7343-43	T496X477(1)004A(2)E500	18.8	8.0	500	574	517	230	125	1
6.3	4.7	B/3528-21	T496B475(1)006A(2)E3K5	0.3	6.0	3500	156	140	62	125	1
6.3	6.8	B/3528-21	T496B685(1)006A(2)E3K5	0.4	6.0	3500	156	140	62	125	1
6.3	10	B/3528-21	T496B106(1)006A(2)E3K5	0.6	6.0	3500	156	140	62	125	1
6.3	15	C/6032-28	T496C156(1)006A(2)E2K0	0.9	6.0	2000	235	212	94	125	1
6.3	22	B/3528-21	T496B226(1)006A(2)E3K5	1.4	6.0	3500	156	140	62	125	1
6.3	22	B/3528-21	T496B226(1)006A(2)E1K5	1.4	6.0	1500	238	214	95	125	1
6.3	22	C/6032-28	T496C226(1)006A(2)E2K0	1.4	6.0	2000	235	212	94	125	1
6.3	33	C/6032-28	T496C336(1)006A(2)E2K0	2.1	6.0	2000	235	212	94	125	1
6.3	33	C/6032-28	T496C336(1)006A(2)E600	2.1	6.0	600	428	385	171	125	1
6.3	47	C/6032-28	T496C476(1)006A(2)E1K6	3.0	6.0	1600	262	236	105	125	1
6.3	47	C/6032-28	T496C476(1)006A(2)E600	3.0	6.0	600	428	385	171	125	1
6.3	47	D/7343-31	T496D476(1)006A(2)E1K0	3.0	6.0	1000	387	348	155	125	1
6.3	68	C/6032-28	T496C686(1)006A(2)E1K2	4.3	6.0	1200	303	273	121	125	1
6.3	68	D/7343-31	T496D686(1)006A(2)E1K0	4.3	6.0	1000	387	348	155	125	1
6.3	100	X/7343-43	T496X107(1)006A(2)E900	6.3	8.0	900	428	385	171	125	1
6.3	100	X/7343-43	T496X107(1)006A(2)E300	6.3	8.0	300	742	668	297	125	1
6.3	100	D/7343-31	T496D107(1)006A(2)E800	6.3	8.0	800	433	390	173	125	1
6.3	100	D/7343-31	T496D107(1)006A(2)E400	6.3	8.0	400	612	551	245	125	1
6.3	100	C/6032-28	T496C107(1)006A(2)E400	6.3	8.0	400	524	472	210	125	1
6.3	150	X/7343-43	T496X157(1)006A(2)E300	9.5	8.0	300	742	668	297	125	1
6.3	150	D/7343-31	T496D157(1)006A(2)E700	9.5	8.0	700	463	417	185	125	1
6.3	150	D/7343-31	T496D157(1)006A(2)E300	9.5	8.0	300	707	636	283	125	1
6.3	220	X/7343-43	T496X227(1)006A(2)E700	13.9	8.0	700	486	437	194	125	1
6.3	220	X/7343-43	T496X227(1)006A(2)E300	13.9	8.0	300	742	668	297	125	1
6.3	220	D/7343-31	T496D227(1)006A(2)E700	13.9	8.0	700	463	417	185	125	1
6.3	220	D/7343-31	T496D227(1)006A(2)E300	13.9	8.0	300	707	636	283	125	1
6.3	330	X/7343-43	T496X337(1)006A(2)E500	20.8	8.0	500	574	517	230	125	1
6.3	330	X/7343-43	T496X337(1)006A(2)E300	20.8	8.0	300	742	668	297	125	1
10	3.3	B/3528-21	T496B335(1)010A(2)E3K5	0.3	6.0	3500	156	140	62	125	1
10	4.7	B/3528-21	T496B475(1)010A(2)E3K5	0.5	6.0	3500	156	140	62	125	1
10	6.8	B/3528-21	T496B685(1)010A(2)E3K5	0.7	6.0	3500	156	140	62	125	1
10	10	C/6032-28	T496C106(1)010A(2)E2K0	1.0	6.0	2000	235	212	94	125	1
10	15	B/3528-21	T496B156(1)010A(2)E3K5	1.5	6.0	3500	156	140	62	125	1
10	15	C/6032-28	T496C156(1)010A(2)E2K0	1.5	6.0	2000	235	212	94	125	1
10	15	C/6032-28	T496C156(1)010A(2)E600	1.5	6.0	600	428	385	171	125	1
10	22	C/6032-28	T496C226(1)010A(2)E2K0	2.2	6.0	2000	235	212	94	125	1
VDC @ 85°C	µF	KEMET/EIA	(See below for part options)	µA @ +20°C Max/5 Min	% @ +20°C 120 Hz % Max	mΩ @ +20°C 100 kHz Max	mA @ +25°C 100 kHz	mA @ +85°C 100 kHz	mA @ +125°C 100 kHz	°C	Reflow Temp ≤ 260°C
Rated Voltage	Rated Cap	Case Code/ Case Size	KEMET Part Number	DC Leakage	DF	ESR	Maximum Allowable Ripple Current			Maximum Operating Temp	MSL

1) To complete KEMET part number, insert M for ± 20% or K for ± 10%. Designates Capacitance tolerance.

(2) To complete KEMET part number, insert T = 100% Matte Tin (Sn) Plated, H = Standard Solder coated (SnPb 5% Pb minimum). Designates Termination Finish. Refer to Ordering Information for additional detail.

Higher voltage ratings and tighter tolerance product including ESR may be substituted within the same size at KEMET's option. Voltage substitution will be marked with the higher voltage rating. Substitutions can include better than series.

Table 1 – Ratings & Part Number Reference cont'd

Rated Voltage	Rated Cap	Case Code/ Case Size	KEMET Part Number	DC Leakage	DF	ESR	Maximum Allowable Ripple Current			Maximum Operating Temp	MSL
							mA @ +25°C 100 kHz	mA @ +85°C 100 kHz	mA @ +125°C 100 kHz		
VDC @ 85°C	µF	KEMET/EIA	(See below for part options)	µA @ +20°C Max/5 Min	% @ +20°C 120 Hz % Max	mΩ @ +20°C 100 kHz Max	mA @ +25°C 100 kHz	mA @ +85°C 100 kHz	mA @ +125°C 100 kHz	°C	Reflow Temp ≤ 260°C
10	22	C/6032-28	T496C226(1)010A(2)E500	2.2	6.0	500	469	422	188	125	1
10	33	D/7343-31	T496D336(1)010A(2)E1K0	3.3	6.0	1000	387	348	155	125	1
10	33	D/7343-31	T496D336(1)010A(2)E400	3.3	6.0	400	612	551	245	125	1
10	33	C/6032-28	T496C336(1)010A(2)E1K6	3.3	6.0	1600	262	236	105	125	1
10	33	C/6032-28	T496C336(1)010A(2)E400	3.3	6.0	400	524	472	210	125	1
10	47	D/7343-31	T496D476(1)010A(2)E1K0	4.7	6.0	1000	387	348	155	125	1
10	47	D/7343-31	T496D476(1)010A(2)E400	4.7	6.0	400	612	551	245	125	1
10	47	C/6032-28	T496C476(1)010A(2)E1K2	4.7	6.0	1200	303	273	121	125	1
10	47	C/6032-28	T496C476(1)010A(2)E400	4.7	6.0	400	524	472	210	125	1
10	68	X/7343-43	T496X686(1)010A(2)E900	6.8	6.0	900	428	385	171	125	1
10	68	D/7343-31	T496D686(1)010A(2)E800	6.8	6.0	800	433	390	173	125	1
10	68	D/7343-31	T496D686(1)010A(2)E400	6.8	6.0	400	612	551	245	125	1
10	100	X/7343-43	T496X107(1)010A(2)E400	10.0	8.0	400	642	578	257	125	1
10	100	D/7343-31	T496D107(1)010A(2)E700	10.0	8.0	700	463	417	185	125	1
10	100	D/7343-31	T496D107(1)010A(2)E400	10.0	8.0	400	612	551	245	125	1
10	150	X/7343-43	T496X157(1)010A(2)E700	15.0	8.0	700	486	437	194	125	1
10	150	X/7343-43	T496X157(1)010A(2)E400	15.0	8.0	400	642	578	257	125	1
10	150	D/7343-31	T496D157(1)010A(2)E700	15.0	8.0	700	463	417	185	125	1
10	150	D/7343-31	T496D157(1)010A(2)E400	15.0	8.0	400	612	551	245	125	1
10	220	X/7343-43	T496X227(1)010A(2)E500	22.0	8.0	500	574	517	230	125	1
10	220	X/7343-43	T496X227(1)010A(2)E300	22.0	8.0	300	742	668	297	125	1
10	220	D/7343-31	T496D227(1)010A(2)E300	22.0	8.0	300	707	636	283	125	1
16	2.2	B/3528-21	T496B225(1)016A(2)E3K5	0.4	6.0	3500	156	140	62	125	1
16	3.3	B/3528-21	T496B335(1)016A(2)E3K5	0.5	6.0	3500	156	140	62	125	1
16	3.3	B/3528-21	T496B335(1)016A(2)E2K1	0.5	6.0	2100	201	181	80	125	1
16	4.7	B/3528-21	T496B475(1)016A(2)E3K5	0.8	6.0	3500	156	140	62	125	1
16	4.7	B/3528-21	T496B475(1)016A(2)E1K6	0.8	6.0	1600	230	207	92	125	1
16	6.8	C/6032-28	T496C685(1)016A(2)E2K0	1.1	6.0	2000	235	212	94	125	1
16	6.8	C/6032-28	T496C685(1)016A(2)E600	1.1	6.0	600	428	385	171	125	1
16	10	B/3528-21	T496B106(1)016A(2)E3K5	1.6	6.0	3500	156	140	62	125	1
16	10	C/6032-28	T496C106(1)016A(2)E2K0	1.6	6.0	2000	235	212	94	125	1
16	10	C/6032-28	T496C106(1)016A(2)E700	1.6	6.0	700	396	356	158	125	1
16	15	C/6032-28	T496C156(1)016A(2)E2K0	2.4	6.0	2000	235	212	94	125	1
16	15	C/6032-28	T496C156(1)016A(2)E600	2.4	6.0	600	428	385	171	125	1
16	22	D/7343-31	T496D226(1)016A(2)E1K0	3.5	6.0	1000	387	348	155	125	1
16	22	D/7343-31	T496D226(1)016A(2)E500	3.5	6.0	500	548	493	219	125	1
16	22	C/6032-28	T496C226(1)016A(2)E1K6	3.5	6.0	1600	262	236	105	125	1
16	22	C/6032-28	T496C226(1)016A(2)E1K0	3.5	6.0	1000	332	299	133	125	1
16	33	D/7343-31	T496D336(1)016A(2)E1K0	5.3	6.0	1000	387	348	155	125	1
16	33	D/7343-31	T496D336(1)016A(2)E400	5.3	6.0	400	612	551	245	125	1
16	47	X/7343-43	T496X476(1)016A(2)E900	7.5	6.0	900	428	385	171	125	1
16	47	X/7343-43	T496X476(1)016A(2)E400	7.5	6.0	400	642	578	257	125	1
16	47	D/7343-31	T496D476(1)016A(2)E800	7.5	6.0	800	433	390	173	125	1
16	47	D/7343-31	T496D476(1)016A(2)E400	7.5	6.0	400	612	551	245	125	1
16	68	D/7343-31	T496D686(1)016A(2)E400	10.9	8.0	400	612	551	245	125	1
16	100	X/7343-43	T496X107(1)016A(2)E700	16.0	8.0	700	486	437	194	125	1
20	1.5	B/3528-21	T496B155(1)020A(2)E5K0	0.3	6.0	5000	130	117	52	125	1
VDC @ 85°C	µF	KEMET/EIA	(See below for part options)	µA @ +20°C Max/5 Min	% @ +20°C 120 Hz % Max	mΩ @ +20°C 100 kHz Max	mA @ +25°C 100 kHz	mA @ +85°C 100 kHz	mA @ +125°C 100 kHz	°C	Reflow Temp ≤ 260°C
Rated Voltage	Rated Cap	Case Code/ Case Size	KEMET Part Number	DC Leakage	DF	ESR	Maximum Allowable Ripple Current			Maximum Operating Temp	MSL

1) To complete KEMET part number, insert M for ± 20% or K for ± 10%. Designates Capacitance tolerance.

2) To complete KEMET part number, insert T = 100% Matte Tin (Sn) Plated, H = Standard Solder coated (SnPb 5% Pb minimum). Designates Termination Finish. Refer to Ordering Information for additional detail.

Higher voltage ratings and tighter tolerance product including ESR may be substituted within the same size at KEMET's option. Voltage substitution will be marked with the higher voltage rating. Substitutions can include better than series.

Table 1 – Ratings & Part Number Reference cont'd

Rated Voltage	Rated Cap	Case Code/ Case Size	KEMET Part Number	DC Leakage	DF	ESR	Maximum Allowable Ripple Current			Maximum Operating Temp	MSL
							mA @ +25°C 100 kHz	mA @ +85°C 100 kHz	mA @ +125°C 100 kHz		
VDC @ 85°C	µF	KEMET/EIA	(See below for part options)	µA @ +20°C Max/5 Min	% @ +20°C 120 Hz % Max	mΩ @ +20°C 100 kHz Max	mA @ +25°C 100 kHz	mA @ +85°C 100 kHz	mA @ +125°C 100 kHz	°C	Reflow Temp ≤ 260°C
20	2.2	B/3528-21	T496B225(1)020A(2)E3K5	0.4	6.0	3500	156	140	62	125	1
20	2.2	B/3528-21	T496B225(1)020A(2)E1K6	0.4	6.0	1600	230	207	92	125	1
20	3.3	B/3528-21	T496B335(1)020A(2)E3K5	0.7	6.0	3500	156	140	62	125	1
20	4.7	C/6032-28	T496C475(1)020A(2)E2K0	0.9	6.0	2000	235	212	94	125	1
20	6.8	C/6032-28	T496C685(1)020A(2)E2K0	1.4	6.0	2000	235	212	94	125	1
20	6.8	C/6032-28	T496C685(1)020A(2)E600	1.4	6.0	600	428	385	171	125	1
20	10	C/6032-28	T496C106(1)020A(2)E2K0	2.0	6.0	2000	235	212	94	125	1
20	10	C/6032-28	T496C106(1)020A(2)E800	2.0	6.0	800	371	334	148	125	1
20	15	D/7343-31	T496D156(1)020A(2)E1K0	3.0	6.0	1000	387	348	155	125	1
20	15	D/7343-31	T496D156(1)020A(2)E500	3.0	6.0	500	548	493	219	125	1
20	15	C/6032-28	T496C156(1)020A(2)E500	3.0	6.0	500	469	422	188	125	1
20	22	D/7343-31	T496D226(1)020A(2)E1K0	4.4	6.0	1000	387	348	155	125	1
20	22	D/7343-31	T496D226(1)020A(2)E500	4.4	6.0	500	548	493	219	125	1
20	33	X/7343-43	T496X336(1)020A(2)E900	6.6	6.0	900	428	385	171	125	1
20	33	X/7343-43	T496X336(1)020A(2)E400	6.6	6.0	400	642	578	257	125	1
20	33	D/7343-31	T496D336(1)020A(2)E400	6.6	6.0	400	612	551	245	125	1
20	47	X/7343-43	T496X476(1)020A(2)E300	9.4	6.0	300	742	668	297	125	1
20	47	D/7343-31	T496D476(1)020A(2)E300	9.4	6.0	300	707	636	283	125	1
25	0.68	B/3528-21	T496B684(1)025A(2)E6K5	0.2	4.0	6500	114	103	46	125	1
25	1	B/3528-21	T496B105(1)025A(2)E5K0	0.3	4.0	5000	130	117	52	125	1
25	1	B/3528-21	T496B105(1)025A(2)E3K5	0.3	4.0	3500	156	140	62	125	1
25	1.5	B/3528-21	T496B155(1)025A(2)E5K0	0.4	6.0	5000	130	117	52	125	1
25	1.5	B/3528-21	T496B155(1)025A(2)E1K6	0.4	6.0	1600	230	207	92	125	1
25	2.2	C/6032-28	T496C225(1)025A(2)E3K5	0.6	6.0	3500	177	159	71	125	1
25	3.3	C/6032-28	T496C335(1)025A(2)E2K5	0.8	6.0	2500	210	189	84	125	1
25	3.3	C/6032-28	T496C335(1)025A(2)E2K1	0.8	6.0	2100	229	206	92	125	1
25	4.7	B/3528-21	T496B475(1)025A(2)E4K0	1.2	6.0	4000	146	131	58	125	1
25	4.7	C/6032-28	T496C475(1)025A(2)E2K5	1.2	6.0	2500	210	189	84	125	1
25	4.7	C/6032-28	T496C475(1)025A(2)E1K3	1.2	6.0	1300	291	262	116	125	1
25	6.8	C/6032-28	T496C685(1)025A(2)E2K0	1.7	6.0	2000	235	212	94	125	1
25	6.8	C/6032-28	T496C685(1)025A(2)E600	1.7	6.0	600	428	385	171	125	1
25	10	C/6032-28	T496C106(1)025A(2)E600	2.5	6.0	600	428	385	171	125	1
25	10	D/7343-31	T496D106(1)025A(2)E1K2	2.5	6.0	1200	354	319	142	125	1
25	10	D/7343-31	T496D106(1)025A(2)E600	2.5	6.0	600	500	450	200	125	1
25	15	C/6032-28	T496C156(1)025A(2)E750	3.8	6.0	750	383	345	153	125	1
25	15	D/7343-31	T496D156(1)025A(2)E1K0	3.8	6.0	1000	387	348	155	125	1
25	15	D/7343-31	T496D156(1)025A(2)E500	3.8	6.0	500	548	493	219	125	1
25	22	X/7343-43	T496X226(1)025A(2)E900	5.5	6.0	900	428	385	171	125	1
25	22	X/7343-43	T496X226(1)025A(2)E400	5.5	6.0	400	642	578	257	125	1
25	22	D/7343-31	T496D226(1)025A(2)E800	5.5	6.0	800	433	390	173	125	1
25	22	D/7343-31	T496D226(1)025A(2)E400	5.5	6.0	400	612	551	245	125	1
35	0.47	B/3528-21	T496B474(1)035A(2)E8K0	0.2	4.0	8000	103	93	41	125	1
35	0.47	B/3528-21	T496B474(1)035A(2)E2K6	0.2	4.0	2600	181	163	72	125	1
35	0.68	B/3528-21	T496B684(1)035A(2)E6K5	0.2	4.0	6500	114	103	46	125	1
35	1	B/3528-21	T496B105(1)035A(2)E5K0	0.4	4.0	5000	130	117	52	125	1
35	1	B/3528-21	T496B105(1)035A(2)E3K1	0.4	4.0	3100	166	149	66	125	1
35	1.5	C/6032-28	T496C155(1)035A(2)E4K5	0.5	6.0	4500	156	140	62	125	1
VDC @ 85°C	µF	KEMET/EIA	(See below for part options)	µA @ +20°C Max/5 Min	% @ +20°C 120 Hz % Max	mΩ @ +20°C 100 kHz Max	mA @ +25°C 100 kHz	mA @ +85°C 100 kHz	mA @ +125°C 100 kHz	°C	Reflow Temp ≤ 260°C
Rated Voltage	Rated Cap	Case Code/ Case Size	KEMET Part Number	DC Leakage	DF	ESR	Maximum Allowable Ripple Current			Maximum Operating Temp	MSL

1) To complete KEMET part number, insert M for ± 20% or K for ± 10%. Designates Capacitance tolerance.

(2) To complete KEMET part number, insert T = 100% Matte Tin (Sn) Plated, H = Standard Solder coated (SnPb 5% Pb minimum). Designates Termination Finish. Refer to Ordering Information for additional detail.

Higher voltage ratings and tighter tolerance product including ESR may be substituted within the same size at KEMET's option. Voltage substitution will be marked with the higher voltage rating. Substitutions can include better than series.

Table 1 – Ratings & Part Number Reference cont'd

Rated Voltage	Rated Cap	Case Code/ Case Size	KEMET Part Number	DC Leakage	DF	ESR	Maximum Allowable Ripple Current			Maximum Operating Temp	MSL
							mA @ +25°C 100 kHz	mA @ +85°C 100 kHz	mA @ +125°C 100 kHz		
VDC @ 85°C	µF	KEMET/EIA	(See below for part options)	µA @ +20°C Max/5 Min	% @ +20°C 120 Hz % Max	mΩ @ +20°C 100 kHz Max	mA @ +25°C 100 kHz	mA @ +85°C 100 kHz	mA @ +125°C 100 kHz	°C	Reflow Temp ≤ 260°C
35	1.5	C/6032-28	T496C155(1)035A(2)E2K6	0.5	6.0	2600	206	185	82	125	1
35	2.2	C/6032-28	T496C225(1)035A(2)E3K5	0.8	6.0	3500	177	159	71	125	1
35	2.2	C/6032-28	T496C225(1)035A(2)E1K6	0.8	6.0	1600	262	236	105	125	1
35	3.3	C/6032-28	T496C335(1)035A(2)E2K5	1.2	6.0	2500	210	189	84	125	1
35	3.3	C/6032-28	T496C335(1)035A(2)E900	1.2	6.0	900	350	315	140	125	1
35	4.7	D/7343-31	T496D475(1)035A(2)E1K5	1.6	6.0	1500	316	284	126	125	1
35	4.7	D/7343-31	T496D475(1)035A(2)E700	1.6	6.0	700	463	417	185	125	1
35	6.8	D/7343-31	T496D685(1)035A(2)E1K3	2.4	6.0	1300	340	306	136	125	1
35	6.8	D/7343-31	T496D685(1)035A(2)E750	2.4	6.0	750	447	402	179	125	1
35	10	X/7343-43	T496X106(1)035A(2)E1K0	3.5	6.0	1000	406	365	162	125	1
35	10	X/7343-43	T496X106(1)035A(2)E500	3.5	6.0	500	574	517	230	125	1
35	10	D/7343-31	T496D106(1)035A(2)E400	3.5	6.0	400	612	551	245	125	1
35	15	X/7343-43	T496X156(1)035A(2)E900	5.3	6.0	900	428	385	171	125	1
35	15	X/7343-43	T496X156(1)035A(2)E500	5.3	6.0	500	574	517	230	125	1
35	15	D/7343-31	T496D156(1)035A(2)E500	5.3	6.0	500	548	493	219	125	1
35	22	X/7343-43	T496X226(1)035A(2)E300	7.7	6.0	300	742	668	297	125	1
50	0.15	B/3528-21	T496B154(1)050A(2)E16K	0.1	4.0	16000	73	66	29	125	1
50	0.22	B/3528-21	T496B224(1)050A(2)E14K	0.1	4.0	14000	78	70	31	125	1
50	0.22	B/3528-21	T496B224(1)050A(2)E10K	0.1	4.0	10000	92	83	37	125	1
50	0.33	B/3528-21	T496B334(1)050A(2)E10K	0.2	4.0	10000	92	83	37	125	1
50	0.33	B/3528-21	T496B334(1)050A(2)E2K6	0.2	4.0	2600	181	163	72	125	1
50	0.47	C/6032-28	T496C474(1)050A(2)E8K0	0.2	4.0	8000	117	105	47	125	1
50	0.47	C/6032-28	T496C474(1)050A(2)E1K9	0.2	4.0	1900	241	217	96	125	1
50	0.68	C/6032-28	T496C684(1)050A(2)E7K0	0.3	4.0	7000	125	113	50	125	1
50	0.68	C/6032-28	T496C684(1)050A(2)E1K7	0.3	4.0	1700	254	229	102	125	1
50	1	C/6032-28	T496C105(1)050A(2)E5K5	0.5	4.0	5500	141	127	56	125	1
50	1	C/6032-28	T496C105(1)050A(2)E2K7	0.5	4.0	2700	202	182	81	125	1
50	1.5	C/6032-28	T496C155(1)050A(2)E5K0	0.8	6.0	5000	148	133	59	125	1
50	1.5	C/6032-28	T496C155(1)050A(2)E2K0	0.8	6.0	2000	235	212	94	125	1
50	2.2	D/7343-31	T496D225(1)050A(2)E2K5	1.1	6.0	2500	245	221	98	125	1
50	2.2	D/7343-31	T496D225(1)050A(2)E900	1.1	6.0	900	408	367	163	125	1
50	3.3	D/7343-31	T496D335(1)050A(2)E2K0	1.7	6.0	2000	274	247	110	125	1
50	3.3	D/7343-31	T496D335(1)050A(2)E1K0	1.7	6.0	1000	387	348	155	125	1
50	4.7	X/7343-43	T496X475(1)050A(2)E1K5	2.4	6.0	1500	332	299	133	125	1
50	4.7	X/7343-43	T496X475(1)050A(2)E400	2.4	6.0	400	642	578	257	125	1
50	4.7	D/7343-31	T496D475(1)050A(2)E400	2.4	6.0	400	612	551	245	125	1
VDC @ 85°C	µF	KEMET/EIA	(See below for part options)	µA @ +20°C Max/5 Min	% @ +20°C 120 Hz % Max	mΩ @ +20°C 100 kHz Max	mA @ +25°C 100 kHz	mA @ +85°C 100 kHz	mA @ +125°C 100 kHz	°C	Reflow Temp ≤ 260°C
Rated Voltage	Rated Cap	Case Code/ Case Size	KEMET Part Number	DC Leakage	DF	ESR	Maximum Allowable Ripple Current			Maximum Operating Temp	MSL

1) To complete KEMET part number, insert M for ± 20% or K for ± 10%. Designates Capacitance tolerance.

2) To complete KEMET part number, insert T = 100% Matte Tin (Sn) Plated, H = Standard Solder coated (SnPb 5% Pb minimum). Designates Termination Finish. Refer to Ordering Information for additional detail.

Higher voltage ratings and tighter tolerance product including ESR may be substituted within the same size at KEMET's option. Voltage substitution will be marked with the higher voltage rating. Substitutions can include better than series.

Recommended Voltage Derating Guidelines

	-55°C to 85°C	85°C to 125°C
% Change in Working DC Voltage with Temperature	V _R	67% of V _R
Recommended Maximum Application Voltage	50% of V _R	33% of V _R

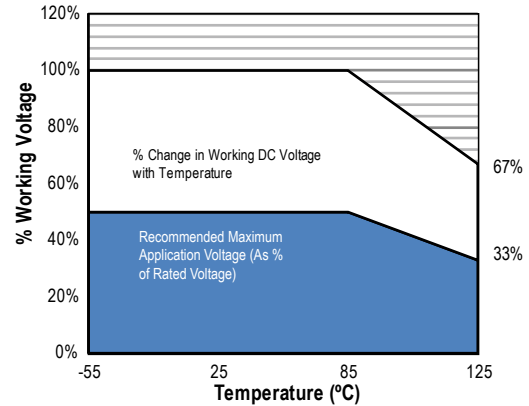

Ripple Current/Ripple Voltage

Permissible AC ripple voltage and current are related to equivalent series resistance (ESR) and the power dissipation capabilities of the device. Permissible AC ripple voltage which may be applied is limited by two criteria:

1. The positive peak AC voltage plus the DC bias voltage, if any, must not exceed the DC voltage rating of the capacitor.
2. The negative peak AC voltage in combination with bias voltage, if any, must not exceed the allowable limits specified for reverse voltage. See the Reverse Voltage section for allowable limits.

The maximum power dissipation by case size can be determined using the table at right. The maximum power dissipation rating stated in the table must be reduced with increasing environmental operating temperatures. Refer to the table below for temperature compensation requirements.

KEMET Case Code	EIA Case Code	Maximum Power Dissipation (P max) mWatts @ 25°C w/+20°C Rise
A	3216-18	75
B	3528-21	85
C	6032-28	110
D	7343-31	150
X	7343-43	165
E	7360-38	200
S	3216-12	60
T	3528-12	70
U	6032-15	90
V	7343-20	125
T510X	7343-43	270
T510E	7360-38	285

The maximum power dissipation rating must be reduced with increasing environmental operating temperatures. Refer to the Temperature Compensation Multiplier table for details.

Temperature Compensation Multipliers for Maximum Ripple Current		
T ≤ 25°C	T ≤ 85°C	T ≤ 125°C
1.00	0.90	0.40

T = Environmental Temperature

Using the P max of the device, the maximum allowable rms ripple current or voltage may be determined.

$$I(max) = \sqrt{P_{max}/R}$$

$$E(max) = Z \sqrt{P_{max}/R}$$

I = rms ripple current (amperes)

E = rms ripple voltage (volts)

P max = maximum power dissipation (watts)

R = ESR at specified frequency (ohms)

Z = Impedance at specified frequency (ohms)

Reverse Voltage

Solid tantalum capacitors are polar devices and may be permanently damaged or destroyed if connected with the wrong polarity. The positive terminal is identified on the capacitor body by a stripe plus in some cases a beveled edge. A small degree of transient reverse voltage is permissible for short periods per the table. The capacitors should not be operated continuously in reverse mode, even within these limits.

Temperature	Permissible Transient Reverse Voltage
25°C	15% of Rated Voltage
85°C	5% of Rated Voltage
125°C	1% of Rated Voltage

Table 2 – Land Dimensions/Courtyard

KEMET	Metric Size Code	Density Level A: Maximum (Most) Land Protrusion (mm)					Density Level B: Median (Nominal) Land Protrusion (mm)					Density Level C: Minimum (Least) Land Protrusion (mm)				
		W	L	S	V1	V2	W	L	S	V1	V2	W	L	S	V1	V2
B	3528-21	2.35	2.21	0.92	6.32	4.00	2.23	1.80	1.12	5.22	3.50	2.13	1.42	1.28	4.36	3.24
C	6032-25	2.35	2.77	2.37	8.92	4.50	2.23	2.37	2.57	7.82	4.00	2.13	1.99	2.73	6.96	3.74
D	7343-31	2.55	2.77	3.67	10.22	5.60	2.43	2.37	3.87	9.12	5.10	2.33	1.99	4.03	8.26	4.84
X ¹	7343-43	2.55	2.77	3.67	10.22	5.60	2.43	2.37	3.87	9.12	5.10	2.33	1.99	4.03	8.26	4.84

Density Level A: For low-density product applications. Recommended for wave solder applications and provides a wider process window for reflow solder processes.

Density Level B: For products with a moderate level of component density. Provides a robust solder attachment condition for reflow solder processes.

Density Level C: For high component density product applications. Before adapting the minimum land pattern variations the user should perform qualification testing based on the conditions outlined in IPC standard 7351 (IPC-7351).

¹ Height of these chips may create problems in wave soldering.

² Land pattern geometry is too small for silkscreen outline.

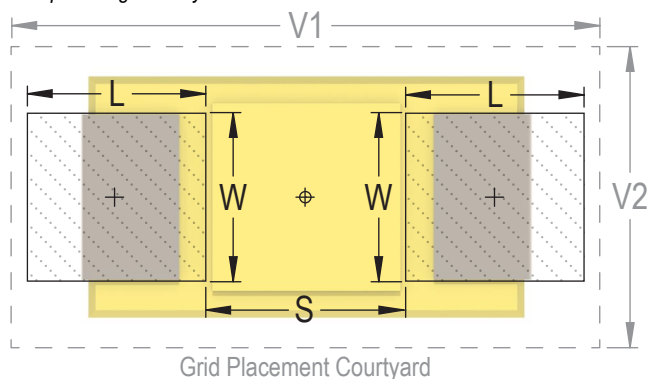

Soldering Process

KEMET's families of surface mount capacitors are compatible with wave (single or dual), convection, IR, or vapor phase reflow techniques. Preheating of these components is recommended to avoid extreme thermal stress. KEMET's recommended profile conditions for convection and IR reflow reflect the profile conditions of the IPC/J-STD-020D standard for moisture sensitivity testing. The devices can safely withstand a maximum of three reflow passes at these conditions.

Please note that although the X/7343-43 case size can withstand wave soldering, the tall profile (4.3 mm maximum) dictates care in wave process development.

Hand soldering should be performed with care due to the difficulty in process control. If performed, care should be taken to avoid contact of the soldering iron to the molded case. The iron should be used to heat the solder pad, applying solder between the pad and the termination, until reflow occurs. Once reflow occurs, the iron should be removed immediately. "Wiping" the edges of a chip and heating the top surface is not recommended.

During typical reflow operations, a slight darkening of the gold-colored epoxy may be observed. This slight darkening is normal and not harmful to the product. Marking permanency is not affected by this change.

Profile Feature	SnPb Assembly	Pb-Free Assembly
Preheat/Soak		
Temperature Minimum (T_{Smin})	100°C	150°C
Temperature Maximum (T_{Smax})	150°C	200°C
Time (t_s) from T_{Smin} to T_{Smax}	60 – 120 seconds	60 – 120 seconds
Ramp-up Rate (T_L to T_p)	3°C/seconds maximum	3°C/seconds maximum
Liquidous Temperature (T_L)	183°C	217°C
Time Above Liquidous (t_L)	60 – 150 seconds	60 – 150 seconds
Peak Temperature (T_p)	220°C* 235°C**	250°C* 260°C**
Time within 5°C of Maximum Peak Temperature (t_p)	20 seconds maximum	30 seconds maximum
Ramp-down Rate (T_p to T_L)	6°C/seconds maximum	6°C/seconds maximum
Time 25°C to Peak Temperature	6 minutes maximum	8 minutes maximum

Note: All temperatures refer to the center of the package, measured on the package body surface that is facing up during assembly reflow.

*Case Size D, E, P, Y, and X

**Case Size A, B, C, H, I, K, M, R, S, T, U, V, W, and Z

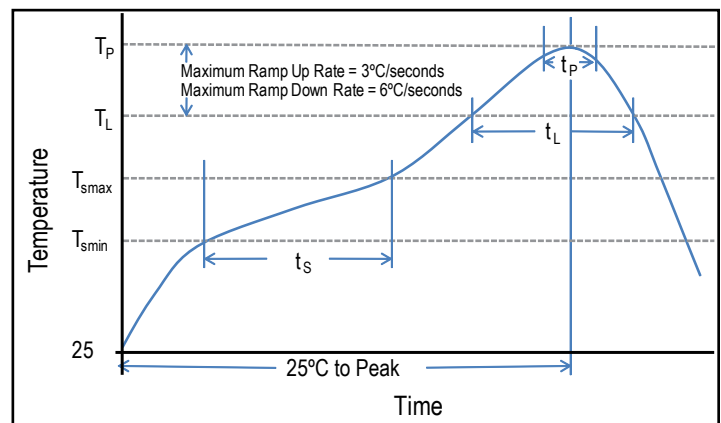

Storage

Tantalum chip capacitors should be stored in normal working environments. While the chips themselves are quite robust in other environments, solderability will be degraded by exposure to high temperatures, high humidity, corrosive atmospheres, and long term storage. In addition, packaging materials will be degraded by high temperature— reels may soften or warp and tape peel force may increase. KEMET recommends that maximum storage temperature not exceed 40°C and maximum storage humidity not exceed 60% relative humidity. Temperature fluctuations should be minimized to avoid condensation on the parts and atmospheres should be free of chlorine and sulphur bearing compounds. For optimized solderability chip stock should be used promptly, preferably within three years of receipt.

Construction

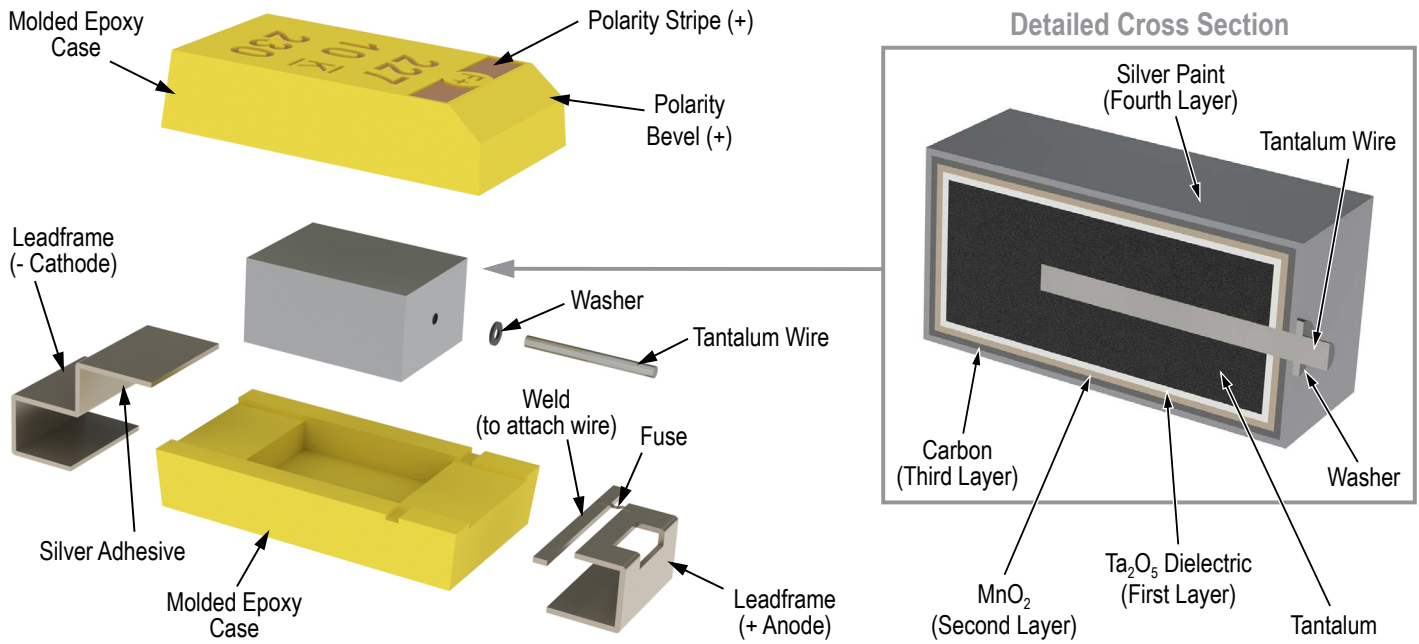

Capacitor Marking

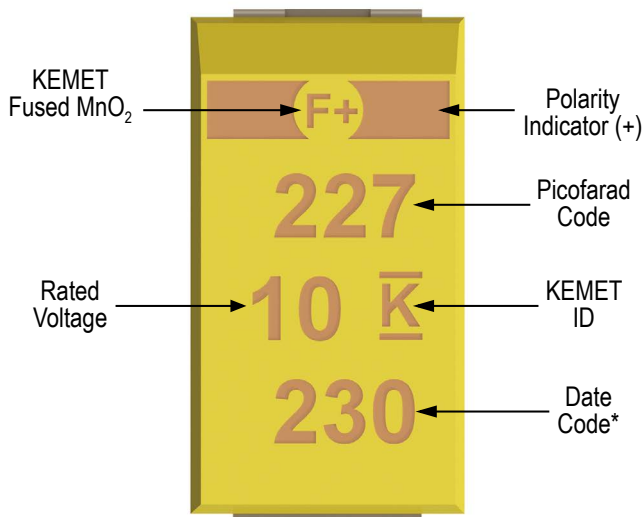

* 230 = 30th week of 2012

Date Code *	
1 st digit = Last number of Year	9 = 2009 0 = 2010 1 = 2011 2 = 2012 3 = 2013 4 = 2014
2 nd and 3 rd digit = Week of the Year	01 = 1 st week of the Year to 52 = 52 nd week of the Year

T496 Series Fused Commercial Off-The-Shelf (COTS) MnO₂ and DLA (DSCC) Drawing 04053

Overview

The T496 Series Commercial Off-The-Shelf (COTS) with a built-in fuse design provides excellent protection from short circuit conditions in applications where damaging high fault currents exist. This series meets the MIL-PRF-55365 requirements

and is suitable for use in high reliability applications, incorporating an intensive testing and screening protocol that is customizable depending on specific customer requirements. The T496 COTS Series is available in standard and low ESR.

Benefits

- Meets or exceeds EIA standard 535BAACC
- Halogen-free epoxy
- Patented fuse assembly which protects against short circuit mode
- DLA (DSCC) Drawing 04053 Available
- Established Reliability Weibull Options B, C, or D
- 100% surge current testing options per MIL-PRF-55365 available
- Capacitance values of 0.15 μF to 470 μF
- Voltage rating of 4 – 50 VDC
- Fuse actuation, 25°C: within 1 second at fault currents of 4 amps and higher
- Continuous current capability: 0.75 amps
- Post actuation resistance, 25°C: 10 M Ω , minimum
- Test tabs on side of case bypass the capacitor element to allow direct testing of the fuse assembly
- RoHS Compliant (100% Sn) and SnPb terminations available
- Standard termination SnPb
- Operating temperature range of -55°C to +125°C
- MSL Level = 1

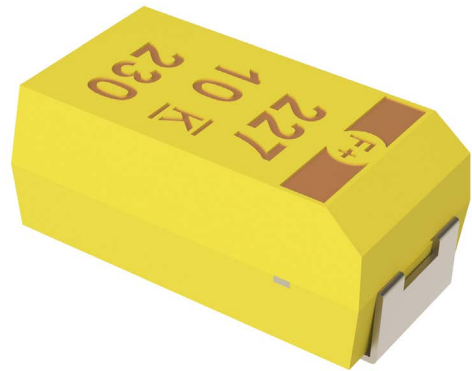

Applications

Typical applications include decoupling and filtering in computing, telecommunications, defense, and industrial end applications requiring built-in fuse capability.

Environmental Compliance

RoHS Compliant (6/6) according to Directive 2002/95/EC when ordered with 100% Sn solder.



RoHS Compliant

SPICE

For a detailed analysis of specific part numbers, please visit www.kemet.com for a free download of KEMET's SPICE software. The KEMET SPICE program is freeware intended to aid design engineers in analyzing the performance of these capacitors over frequency, temperature, ripple, and DC bias conditions.

Ordering Information

T	496	X	227	M	010	B	T	61	10	
Capacitor Class	Series	Case Size	Capacitance Code (pF)	Capacitance Tolerance	Voltage	Failure Rate/Design	Lead Material	Performance	ESR	Packaging (C-Spec)
T = Tantalum	Fail Safe	B, C, D, X	First two digits represent significant figures. Third digit specifies number of zeros.	K = ±10% M = ±20%	004 = 4 V 006 = 6.3 V 010 = 10 V 015 = 15 V 020 = 20 V 025 = 25 V 035 = 35 V 050 = 50 V	B = 0.1%/1,000 hours C = 0.01%/1,000 hours D = 0.001%/1,000 hours A = Non-Weibull Graded	T = 100% Matte Tin (Sn) Plated H = Standard Solder Coated (SnPb 5% Pb minimum) C = Hot Solder Dipped K = Solder Fused	61 = Surge None 62 = Surge @ 25°C after Weibull 63 = Surge -55°C and +85°C after Weibull 64 = Surge -55°C and +85°C before Weibull	10 = Standard 20 = Low	Blank = 7" Reel 7280 = 13" Reel

Ordering Information DLA (DSCC) Drawing 04053

04053-	001	B
Drawing Number	Dash Number	Reliability Grade
	See Part Number List	B = 0.1%/1,000 hours C = 0.01%/1,000 hours D = 0.001%/1,000 hours A = Non-Weibull Graded

Performance Characteristics

Item	Performance Characteristics
Operating Temperature	-55°C to 125°C
Rated Capacitance Range	0.15 µF – 470 µF @ 120 Hz/25°C
Capacitance Tolerance	K Tolerance (10%), M Tolerance (20%)
Rated Voltage Range	4 – 50 V
DF (120 Hz)	Refer to Part Number Electrical Specification Table
ESR (100 kHz)	Refer to Part Number Electrical Specification Table
Leakage Current	≤ 0.01 CV (µA) at rated voltage after 5 minutes

Qualification

Test	Condition	Characteristics				
Endurance	85°C @ rated voltage, 2,000 hours 125°C @ 2/3 rated voltage, 2,000 hours	Δ C/C	Within ±10% of initial value			
		DF	Within initial limits			
		DCL	Within 1.25 x initial limit			
		ESR	Within initial limits			
Moisture Resistance	65°C to -10°C, 100% RH, 20 cycles, no load	Δ C/C	Within +/-15% of initial value			
		DF	Within 150 x initial limit			
		DCL	Within 200 x initial limit			
Thermal Shock	MIL-STD-202, Method 107, Condition B, mounted, -55°C to 125°C, 1,000 cycles	Δ C/C	Within ±5% of initial value			
		DF	Within initial limits			
		DCL	Within 1.25 x initial limit			
		ESR	Within initial limits			
Temperature Stability	Extreme temperature exposure at a succession of continuous steps at +25°C, -55°C, +25°C, +85°C, +125°C, +25°C		+25°C	-55°C	+85°C	+125°C
		Δ C/C	IL*	±10%	±10%	±20%
		DF	IL	IL	1.5 x IL	1.5 x IL
Resistance to Solder Heat	MIL-STD-202, Method 210, 1 cycle	DCL	IL	n/a	10 x IL	12 x IL
		Δ C/C	Within ±5% of initial value			
		DF	Within initial limits			
Surge Voltage	25°C and 85°C, 1.32 x rated voltage 1,000 cycles (125°C, 1.2 x rated voltage)	DCL	Within initial limits			
		ESR	Within initial limits			
		Δ C/C	Within ±5% of initial value			
		DF	Within initial limits			
Resistance to Solvents	MIL-STD-202, Method 215, Aqueous wash chemical or equivalent	DCL	Within initial limits			
		DF	Within initial limits			
		Δ C/C	Within ±10 of initial value			
Mechanical Shock/Vibration	MIL-STD-202, Method 213, Condition I, 100 G peak MIL-STD-202, Method 204, Condition D, 10 Hz to 2,000 Hz, 20 G peak	DCL	Within initial limits			
		DF	Within initial limits			
		Δ C/C	Within ±10% of initial value			

*IL = Initial limit

Certification

MIL-PRF-55365/8
DSCC Drawing 04053

Electrical Characteristics

ESR vs. Frequency

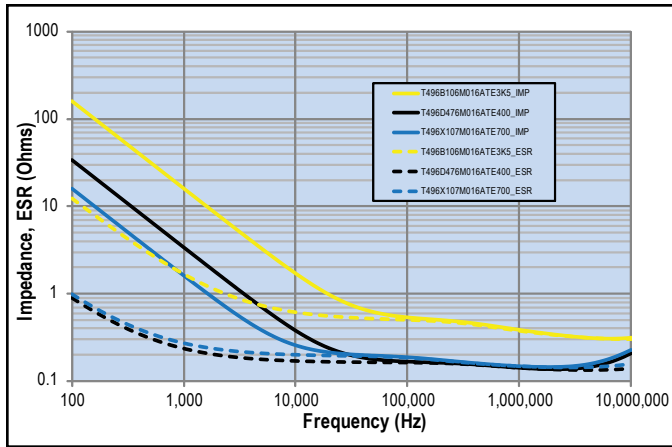

Capacitance vs. Frequency

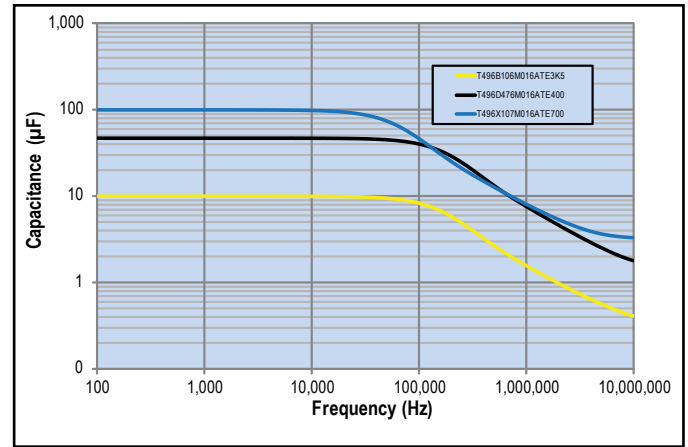

Dimensions – Millimeters (Inches)

Metric will govern

CATHODE (-) END VIEW

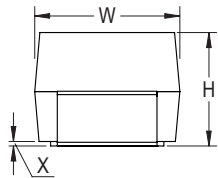

SIDE VIEW



ANODE (+) END VIEW

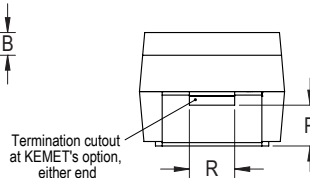

BOTTOM VIEW

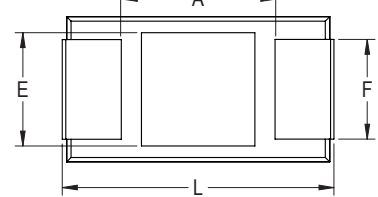

Case Size		Component												
KEMET	EIA	L*	W*	H*	F* ±0.1 ±(0.004)	S* ±0.3 ±(0.012)	B* ±0.15 (Ref) ±0.006	X (Ref)	P (Ref)	R (Ref)	T (Ref)	A (Min)	G (Ref)	E (Ref)
B	3528-21	3.5 ±0.2 (0.138 ±0.008)	2.8 ±0.2 (0.110 ±0.008)	1.9 ±0.2 (0.075 ±0.008)	2.2 (0.087)	0.8 (0.031)	0.4 (0.016)	0.10 ±0.10 (0.004 ±0.004)	0.5 (0.020)	1.0 (0.039)	0.13 (0.005)	1.1 (0.043)	1.8 (0.071)	2.2 (0.087)
C	6032-28	6.0 ±0.3 (0.236 ±0.03)	3.2 ±0.3 (0.126 ±0.012)	2.5 ±0.3 (0.098 ±0.012)	2.2 (0.087)	1.3 (0.051)	0.5 (0.020)	0.10 ±0.10 (0.004 ±0.004)	0.9 (0.035)	1.0 (0.039)	0.13 (0.005)	2.5 (0.098)	2.8 (0.110)	2.4 (0.094)
D	7343-31	7.3 ±0.3 (0.287 ±0.012)	4.3 ±0.3 (0.169 ±0.012)	2.8 ±0.3 (0.110 ±0.012)	2.4 (0.094)	1.3 (0.051)	0.5 (0.020)	0.10 ±0.10 (0.004 ±0.004)	0.9 (0.035)	1.0 (0.039)	0.13 (0.005)	3.8 (0.150)	3.5 (0.138)	3.5 (0.138)
X	7343-43	7.3 ±0.3 (0.287 ±0.012)	4.0 ±0.3 (0.169 ±0.012)	4.0 ±0.3 (0.157 ±0.012)	2.4 (0.094)	1.3 (0.051)	0.5 (0.020)	0.10 ±0.10 (0.004 ±0.004)	1.7 (0.067)	1.0 (0.039)	0.13 (0.005)	3.8 (0.150)	3.5 (0.138)	3.5 (0.138)

Notes: (Ref) – Dimensions provided for reference only. No dimensions provided for B, P or R because low profile cases do not have a bevel or a notch.

* MIL-PRF-55365/8 specified dimensions

Table 1 – Ratings & Part Number Reference

Rated Voltage	Rated Capacitance	Case Code/ Case Size	KEMET Part Number	DC Leakage	DF	ESR	DLA (DSCC)	Maximum Operating Temp
VDC @ 85°C	µF	KEMET/EIA	(See below for part options)	µA @ +20°C Maximum/ 5 Minutes	% @ +20°C 120 Hz Maximum	mΩ @ +20°C 100 kHz Maximum	Drawing Number	°C
4	68	C/6032-28	T496C686(1)004(2)(3)(4)10	2.7	6.0	1600	N/A	
4	68	C/6032-28	T496C686(1)004(2)(3)(4)20	2.7	6.0	400	N/A	
4	68	C/6032-28	T496C686M004(2)H4095	2.7	6.0	1600	04053-001(2)	
4	100	C/6032-28	T496C107(1)004(2)(3)(4)10	4.0	8.0	1200	N/A	
4	100	C/6032-28	T496C107M004(2)H4095	4.0	8.0	1200	04053-002(2)	
4	150	D/7343-31	T496D157(1)004(2)(3)(4)10	6.0	8.0	800	N/A	
4	150	D/7343-31	T496D157M004(2)H4095	6.0	8.0	800	04053-003(2)	
4	150	C/6032-28	T496C157(1)004(2)(3)(4)10	6.0	8.0	1200	N/A	
4	220	D/7343-31	T496D227(1)004(2)(3)(4)10	8.8	8.0	700	N/A	
4	220	D/7343-31	T496D227(1)004(2)(3)(4)20	8.8	8.0	400	N/A	
4	220	D/7343-31	T496D227M004(2)H4095	8.8	8.0	700	04053-004(2)	
4	330	D/7343-31	T496D337(1)004(2)(3)(4)10	13.2	8.0	700	N/A	
4	330	D/7343-31	T496D337(1)004(2)(3)(4)20	13.2	8.0	400	N/A	
4	330	D/7343-31	T496D337M004(2)H4095	13.2	8.0	700	04053-005(2)	
4	330	X/7343-43	T496X337(1)004(2)(3)(4)10	13.2	8.0	700	N/A	
4	330	X/7343-43	T496X337M004(2)H4095	13.2	8.0	700	04053-006(2)	
4	470	X/7343-43	T496X477(1)004(2)(3)(4)10	18.8	8.0	500	N/A	
4	470	X/7343-43	T496X477M004(2)H4095	18.8	8.0	500	04053-007(2)	
6.3	4.7	B/3528-21	T496B475(1)006(2)(3)(4)10	0.3	6.0	3500	N/A	
6.3	4.7	B/3528-21	T496B475M006(2)H4095	0.3	6.0	3500	04053-008(2)	
6.3	6.8	B/3528-21	T496B685(1)006(2)(3)(4)10	0.4	6.0	3500	N/A	
6.3	6.8	B/3528-21	T496B685M006(2)H4095	0.4	6.0	3500	04053-009(2)	
6.3	10	B/3528-21	T496B106(1)006(2)(3)(4)10	0.6	6.0	3500	N/A	
6.3	10	B/3528-21	T496B106M006(2)H4095	0.6	6.0	3500	04053-010(2)	
6.3	15	C/6032-28	T496C156(1)006(2)(3)(4)10	0.9	6.0	2000	N/A	
6.3	15	C/6032-28	T496C156M006(2)H4095	0.9	6.0	2000	04053-011(2)	
6.3	22	B/3528-21	T496B226(1)006(2)(3)(4)10	1.4	6.0	3500	N/A	
6.3	22	B/3528-21	T496B226(1)006(2)(3)(4)20	1.4	6.0	1500	N/A	
6.3	22	B/3528-21	T496B226M006(2)H4095	1.4	6.0	3500	04053-012(2)	
6.3	22	C/6032-28	T496C226(1)006(2)(3)(4)10	1.4	6.0	2000	N/A	
6.3	22	C/6032-28	T496C226M006(2)H4095	1.4	6.0	2000	04053-013(2)	
6.3	33	C/6032-28	T496C336(1)006(2)(3)(4)10	2.1	6.0	2000	N/A	
6.3	33	C/6032-28	T496C336(1)006(2)(3)(4)20	2.1	6.0	600	N/A	
6.3	33	C/6032-28	T496C336M006(2)H4095	2.1	6.0	2000	04053-014(2)	
6.3	47	C/6032-28	T496C476(1)006(2)(3)(4)10	3.0	6.0	1600	N/A	
6.3	47	C/6032-28	T496C476(1)006(2)(3)(4)20	3.0	6.0	600	N/A	
6.3	47	C/6032-28	T496C476M006(2)H4095	3.0	6.0	1600	04053-016(2)	
6.3	47	D/7343-31	T496D476(1)006(2)(3)(4)10	3.0	6.0	1000	N/A	
6.3	47	D/7343-31	T496D476M006(2)H4095	3.0	6.0	1000	04053-015(2)	
6.3	68	C/6032-28	T496C686(1)006(2)(3)(4)10	4.3	6.0	1200	N/A	
6.3	68	C/6032-28	T496C686M006(2)H4095	4.3	6.0	1200	04053-018(2)	
6.3	68	D/7343-31	T496D686(1)006(2)(3)(4)10	4.3	6.0	1000	N/A	
6.3	68	D/7343-31	T496D686M006(2)H4095	4.3	6.0	1000	04053-017(2)	
6.3	100	X/7343-43	T496X107(1)006(2)(3)(4)10	6.3	8.0	900	N/A	
6.3	100	X/7343-43	T496X107(1)006(2)(3)(4)20	6.3	8.0	300	N/A	
6.3	100	X/7343-43	T496X107M006(2)H4095	6.3	8.0	300	04053-019(2)	
6.3	100	D/7343-31	T496D107(1)006(2)(3)(4)10	6.3	8.0	800	N/A	
VDC @ 85°C	µF	KEMET/EIA	(See below for part options)	µA @ +20°C Maximum/ 5 Minutes	% @ +20°C 120 Hz Maximum	mΩ @ +20°C 100 kHz Maximum	Drawing Number	°C
Rated Voltage	Rated Capacitance	Case Code/ Case Size	KEMET Part Number	DC Leakage	DF	ESR	DLA (DSCC)	Maximum Operating Temp

(1) To complete KEMET part number, insert M for ±20% or K for ±10%. Designates Capacitance tolerance.

(2) To complete KEMET part number, insert B (0.1%/1,000 hours), C (0.01%/1,000 hours), D (0.001%/1,000 hours), or A (Non-Weibull Graded).

(3) To complete KEMET part number, insert C = Hot Solder Dipped, H = Solder Plated, K = Solder Fused, or T = 100% Tin (Sn). Designates Termination Finish.

(4) To complete KEMET part number, insert 61 = No Surge, 62 = 10 cycles Surge +25°C, 63 = 10 cycles Surge -55°C and +85°C after Weibull or 64 = 10 cycles Surge -55°C and +85°C before Weibull; N/A for DLA (DSCC) 04053 product - 4095 applies.

Table 1 – Ratings & Part Number Reference cont'd

Rated Voltage	Rated Capacitance	Case Code/ Case Size	KEMET Part Number	DC Leakage	DF	ESR	DLA (DSCC)	Maximum Operating Temp
VDC @ 85°C	µF	KEMET/EIA	(See below for part options)	µA @ +20°C Maximum/ 5 Minutes	% @ +20°C 120 Hz Maximum	mΩ @ +20°C 100 kHz Maximum	Drawing Number	°C
6.3	100	D/7343-31	T496D107(1)006(2)(3)(4)20	6.3	8.0	400	N/A	
6.3	100	D/7343-31	T496D107M006(2)H4095	6.3	8.0	800	04053-020(2)	
6.3	100	C/6032-28	T496C107(1)006(2)(3)(4)10	6.3	8.0	400	N/A	
6.3	150	D/7343-31	T496D157(1)006(2)(3)(4)10	9.5	8.0	700	N/A	
6.3	150	D/7343-31	T496D157(1)006(2)(3)(4)20	9.5	8.0	300	N/A	
6.3	150	D/7343-31	T496D157M006(2)H4095	9.5	8.0	700	04053-021(2)	
6.3	150	X/7343-43	T496X157(1)006(2)(3)(4)10	9.5	8.0	300	N/A	
6.3	220	X/7343-43	T496X227(1)006(2)(3)(4)10	13.9	8.0	700	N/A	
6.3	220	X/7343-43	T496X227(1)006(2)(3)(4)20	13.9	8.0	300	N/A	
6.3	220	X/7343-43	T496X227M006(2)H4095	13.9	8.0	700	04053-023(2)	
6.3	220	D/7343-31	T496D227(1)006(2)(3)(4)10	13.9	8.0	700	N/A	
6.3	220	D/7343-31	T496D227(1)006(2)(3)(4)20	13.9	8.0	300	N/A	
6.3	220	D/7343-31	T496D227M006(2)H4095	13.9	8.0	700	04053-022(2)	
6.3	330	X/7343-43	T496X337(1)006(2)(3)(4)10	20.8	8.0	500	N/A	
6.3	330	X/7343-43	T496X337(1)006(2)(3)(4)20	20.8	8.0	300	N/A	
6.3	330	X/7343-43	T496X337M006(2)H4095	20.8	8.0	500	04053-024(2)	
10	3.3	B/3528-21	T496B335(1)010(2)(3)(4)10	0.3	6.0	3500	N/A	
10	3.3	B/3528-21	T496B335M010(2)H4095	0.3	6.0	3500	04053-025(2)	
10	4.7	B/3528-21	T496B475(1)010(2)(3)(4)10	0.5	6.0	3500	N/A	
10	4.7	B/3528-21	T496B475M010(2)H4095	0.5	6.0	3500	04053-026(2)	
10	6.8	B/3528-21	T496B685(1)010(2)(3)(4)10	0.7	6.0	3500	N/A	
10	6.8	B/3528-21	T496B685M010(2)H4095	0.7	6.0	3500	04053-027(2)	
10	10	C/6032-28	T496C106(1)010(2)(3)(4)10	1.0	6.0	2000	N/A	
10	10	C/6032-28	T496C106M010(2)H4095	1.0	6.0	2000	04053-028(2)	
10	15	B/3528-21	T496B156(1)010(2)(3)(4)10	1.5	6.0	3500	N/A	
10	15	B/3528-21	T496B156M010(2)H4095	1.5	6.0	3500	04053-029(2)	
10	15	C/6032-28	T496C156(1)010(2)(3)(4)10	1.5	6.0	2000	N/A	
10	15	C/6032-28	T496C156(1)010(2)(3)(4)20	1.5	6.0	600	N/A	
10	15	C/6032-28	T496C156M010(2)H4095	1.5	6.0	2000	04053-030(2)	
10	22	C/6032-28	T496C226(1)010(2)(3)(4)10	2.2	6.0	2000	N/A	
10	22	C/6032-28	T496C226(1)010(2)(3)(4)20	2.2	6.0	500	N/A	
10	22	C/6032-28	T496C226M010(2)H4095	2.2	6.0	2000	04053-031(2)	
10	33	D/7343-31	T496D336(1)010(2)(3)(4)10	3.3	6.0	1000	N/A	
10	33	D/7343-31	T496D336(1)010(2)(3)(4)20	3.3	6.0	400	N/A	
10	33	D/7343-31	T496D336M010(2)H4095	3.3	6.0	1000	04053-032(2)	
10	33	C/6032-28	T496C336(1)010(2)(3)(4)10	3.3	6.0	1600	N/A	
10	33	C/6032-28	T496C336(1)010(2)(3)(4)20	3.3	6.0	400	N/A	
10	33	C/6032-28	T496C336M010(2)H4095	3.3	6.0	1600	04053-033(2)	
10	47	D/7343-31	T496D476(1)010(2)(3)(4)10	4.7	6.0	1000	N/A	
10	47	D/7343-31	T496D476(1)010(2)(3)(4)20	4.7	6.0	400	N/A	
10	47	D/7343-31	T496D476M010(2)H4095	4.7	6.0	1000	04053-034(2)	
10	47	C/6032-28	T496C476(1)010(2)(3)(4)10	4.7	6.0	1200	N/A	
10	47	C/6032-28	T496C476(1)010(2)(3)(4)20	4.7	6.0	400	N/A	
10	47	C/6032-28	T496C476M010(2)H4095	4.7	6.0	1200	04053-035(2)	
10	68	X/7343-43	T496X686(1)010(2)(3)(4)10	6.8	6.0	900	N/A	
10	68	X/7343-43	T496X686M010(2)H4095	6.8	6.0	900	04053-036(2)	
10	68	D/7343-31	T496D686(1)010(2)(3)(4)10	6.8	6.0	800	N/A	
VDC @ 85°C	µF	KEMET/EIA	(See below for part options)	µA @ +20°C Maximum/ 5 Minutes	% @ +20°C 120 Hz Maximum	mΩ @ +20°C 100 kHz Maximum	Drawing Number	°C
Rated Voltage	Rated Capacitance	Case Code/ Case Size	KEMET Part Number	DC Leakage	DF	ESR	DLA (DSCC)	Maximum Operating Temp

(1) To complete KEMET part number, insert M for ±20% or K for ±10%. Designates Capacitance tolerance.

(2) To complete KEMET part number, insert B (0.1%/1,000 hours), C (0.01%/1,000 hours), D (0.001%/1,000 hours), or A (Non-Weibull Graded).

(3) To complete KEMET part number, insert C = Hot Solder Dipped, H = Solder Plated, K = Solder Fused, or T = 100% Tin (Sn). Designates Termination Finish.

(4) To complete KEMET part number, insert 61 = No Surge, 62 = 10 cycles Surge +25°C, 63 = 10 cycles Surge -55°C and +85°C after Weibull or 64 = 10 cycles Surge -55°C and +85°C before Weibull; N/A for DLA (DSCC) 04053 product - 4095 applies.

Table 1 – Ratings & Part Number Reference cont'd

Rated Voltage	Rated Capacitance	Case Code/ Case Size	KEMET Part Number	DC Leakage	DF	ESR	DLA (DSCC)	Maximum Operating Temp
VDC @ 85°C	µF	KEMET/EIA	(See below for part options)	µA @ +20°C Maximum/ 5 Minutes	% @ +20°C 120 Hz Maximum	mΩ @ +20°C 100 kHz Maximum	Drawing Number	°C
10	68	D/7343-31	T496D686(1)010(2)(3)(4)20	6.8	6.0	400	N/A	
10	68	D/7343-31	T496D686M010(2)H4095	6.8	6.0	800	04053-037(2)	
10	100	X/7343-43	T496X107(1)010(2)(3)(4)10	10.0	8.0	400	N/A	
10	100	D/7343-31	T496D107(1)010(2)(3)(4)10	10.0	8.0	700	N/A	
10	100	D/7343-31	T496D107(1)010(2)(3)(4)20	10.0	8.0	400	N/A	
10	100	D/7343-31	T496D107M010(2)H4095	10.0	8.0	700	04053-038(2)	
10	150	X/7343-43	T496X157(1)010(2)(3)(4)10	15.0	8.0	700	N/A	
10	150	X/7343-43	T496X157(1)010(2)(3)(4)20	15.0	8.0	400	N/A	
10	150	X/7343-43	T496X157M010(2)H4095	15.0	8.0	700	04053-039(2)	
10	150	D/7343-31	T496D157(1)010(2)(3)(4)10	15.0	8.0	700	N/A	
10	150	D/7343-31	T496D157(1)010(2)(3)(4)20	15.0	8.0	400	N/A	
10	150	D/7343-31	T496D157M010(2)H4095	15.0	8.0	700	04053-040(2)	
10	220	X/7343-43	T496X227(1)010(2)(3)(4)10	22.0	8.0	500	N/A	
10	220	X/7343-43	T496X227(1)010(2)(3)(4)20	22.0	8.0	300	N/A	
10	220	X/7343-43	T496X227M010(2)H4095	22.0	8.0	500	04053-041(2)	
10	220	D/7343-31	T496D227(1)010(2)(3)(4)10	22.0	8.0	300	N/A	
16	2.2	B/3528-21	T496B225(1)016(2)(3)(4)10	0.4	6.0	3500	N/A	
16	2.2	B/3528-21	T496B225M016(2)H4095	0.4	6.0	3500	04053-042(2)	
16	3.3	B/3528-21	T496B335(1)016(2)(3)(4)10	0.5	6.0	3500	N/A	
16	3.3	B/3528-21	T496B335(1)016(2)(3)(4)20	0.5	6.0	2100	N/A	
16	3.3	B/3528-21	T496B335M016(2)H4095	0.5	6.0	3500	04053-043(2)	
16	4.7	B/3528-21	T496B475(1)016(2)(3)(4)10	0.8	6.0	3500	N/A	
16	4.7	B/3528-21	T496B475(1)016(2)(3)(4)20	0.8	6.0	1600	N/A	
16	4.7	B/3528-21	T496B475M016(2)H4095	0.8	6.0	3500	04053-044(2)	
16	6.8	C/6032-28	T496C685(1)016(2)(3)(4)10	1.1	6.0	2000	N/A	
16	6.8	C/6032-28	T496C685(1)016(2)(3)(4)20	1.1	6.0	600	N/A	
16	6.8	C/6032-28	T496C685M016(2)H4095	1.1	6.0	2000	04053-045(2)	
16	10	B/3528-21	T496B106(1)016(2)(3)(4)10	1.6	6.0	3500	N/A	
16	10	B/3528-21	T496B106M016(2)H4095	1.6	6.0	3500	04053-046(2)	
16	10	C/6032-28	T496C106(1)016(2)(3)(4)10	1.6	6.0	2000	N/A	
16	10	C/6032-28	T496C106(1)016(2)(3)(4)20	1.6	6.0	700	N/A	
16	10	C/6032-28	T496C106M016(2)H4095	1.6	6.0	2000	04053-047(2)	
16	15	C/6032-28	T496C156(1)016(2)(3)(4)10	2.4	6.0	2000	N/A	
16	15	C/6032-28	T496C156(1)016(2)(3)(4)20	2.4	6.0	600	N/A	
16	15	C/6032-28	T496C156M016(2)H4095	2.4	6.0	2000	04053-048(2)	
16	22	D/7343-31	T496D226(1)016(2)(3)(4)10	3.5	6.0	1000	N/A	
16	22	D/7343-31	T496D226(1)016(2)(3)(4)20	3.5	6.0	500	N/A	
16	22	D/7343-31	T496D226M016(2)H4095	3.5	6.0	1000	04053-049(2)	
16	22	C/6032-28	T496C226(1)016(2)(3)(4)10	3.5	6.0	1600	N/A	
16	22	C/6032-28	T496C226(1)016(2)(3)(4)20	3.5	6.0	1000	N/A	
16	22	C/6032-28	T496C226M016(2)H4095	3.5	6.0	1600	04053-050(2)	
16	33	D/7343-31	T496D336(1)016(2)(3)(4)10	5.3	6.0	1000	N/A	
16	33	D/7343-31	T496D336(1)016(2)(3)(4)20	5.3	6.0	400	N/A	
16	33	D/7343-31	T496D336M016(2)H4095	5.3	6.0	1000	04053-051(2)	
16	47	X/7343-43	T496X476(1)016(2)(3)(4)10	7.5	6.0	900	N/A	
16	47	X/7343-43	T496X476(1)016(2)(3)(4)20	7.5	6.0	400	N/A	
16	47	X/7343-43	T496X476M016(2)H4095	7.5	6.0	900	04053-052(2)	
VDC @ 85°C	µF	KEMET/EIA	(See below for part options)	µA @ +20°C Maximum/ 5 Minutes	% @ +20°C 120 Hz Maximum	mΩ @ +20°C 100 kHz Maximum	Drawing Number	°C
Rated Voltage	Rated Capacitance	Case Code/ Case Size	KEMET Part Number	DC Leakage	DF	ESR	DLA (DSCC)	Maximum Operating Temp

(1) To complete KEMET part number, insert M for ±20% or K for ±10%. Designates Capacitance tolerance.

(2) To complete KEMET part number, insert B (0.1%/1,000 hours), C (0.01%/1,000 hours), D (0.001%/1,000 hours), or A (Non-Weibull Graded).

(3) To complete KEMET part number, insert C = Hot Solder Dipped, H = Solder Plated, K = Solder Fused, or T = 100% Tin (Sn). Designates Termination Finish.

(4) To complete KEMET part number, insert 61 = No Surge, 62 = 10 cycles Surge +25°C, 63 = 10 cycles Surge -55°C and +85°C after Weibull or 64 = 10 cycles Surge -55°C and +85°C before Weibull; N/A for DLA (DSCC) 04053 product - 4095 applies.

Table 1 – Ratings & Part Number Reference cont'd

Rated Voltage	Rated Capacitance	Case Code/ Case Size	KEMET Part Number	DC Leakage	DF	ESR	DLA (DSCC)	Maximum Operating Temp
VDC @ 85°C	µF	KEMET/EIA	(See below for part options)	µA @ +20°C Maximum/ 5 Minutes	% @ +20°C 120 Hz Maximum	mΩ @ +20°C 100 kHz Maximum	Drawing Number	°C
16	47	D/7343-31	T496D476(1)016(2)(3)(4)10	7.5	6.0	800	N/A	
16	47	D/7343-31	T496D476(1)016(2)(3)(4)20	7.5	6.0	400	N/A	
16	47	D/7343-31	T496D476M016(2)H4095	7.5	6.0	800	04053-053(2)	
16	68	D/7343-31	T496D686(1)016(2)(3)(4)10	10.9	8.0	400	N/A	
16	100	X/7343-43	T496X107(1)016(2)(3)(4)10	16.0	8.0	700	N/A	
16	100	X/7343-43	T496X107M016(2)H4095	16.0	8.0	700	04053-054(2)	
20	1.5	B/3528-21	T496B155(1)020(2)(3)(4)10	0.3	6.0	5000	N/A	
20	1.5	B/3528-21	T496B155M020(2)H4095	0.3	6.0	5000	04053-055(2)	
20	2.2	B/3528-21	T496B225(1)020(2)(3)(4)10	0.4	6.0	3500	N/A	
20	2.2	B/3528-21	T496B225(1)020(2)(3)(4)20	0.4	6.0	1600	N/A	
20	2.2	B/3528-21	T496B225M020(2)H4095	0.4	6.0	3500	04053-056(2)	
20	3.3	B/3528-21	T496B335(1)020(2)(3)(4)10	0.7	6.0	3500	N/A	
20	3.3	B/3528-21	T496B335M020(2)H4095	0.7	6.0	3500	04053-057(2)	
20	4.7	C/6032-28	T496C475(1)020(2)(3)(4)10	0.9	6.0	2000	N/A	
20	4.7	C/6032-28	T496C475M020(2)H4095	0.9	6.0	2000	04053-058(2)	
20	6.8	C/6032-28	T496C685(1)020(2)(3)(4)10	1.4	6.0	2000	N/A	
20	6.8	C/6032-28	T496C685(1)020(2)(3)(4)20	1.4	6.0	600	N/A	
20	6.8	C/6032-28	T496C685M020(2)H4095	1.4	6.0	2000	04053-059(2)	
20	10	C/6032-28	T496C106(1)020(2)(3)(4)10	2.0	6.0	2000	N/A	
20	10	C/6032-28	T496C106(1)020(2)(3)(4)20	2.0	6.0	800	N/A	
20	10	C/6032-28	T496C106M020(2)H4095	2.0	6.0	2000	04053-060(2)	
20	15	D/7343-31	T496D156(1)020(2)(3)(4)10	3.0	6.0	1000	N/A	
20	15	D/7343-31	T496D156(1)020(2)(3)(4)20	3.0	6.0	500	N/A	
20	15	D/7343-31	T496D156M020(2)H4095	3.0	6.0	1000	04053-061(2)	
20	15	C/6032-28	T496C156(1)020(2)(3)(4)10	3.0	6.0	500	N/A	
20	22	D/7343-31	T496D226(1)020(2)(3)(4)10	4.4	6.0	1000	N/A	
20	22	D/7343-31	T496D226(1)020(2)(3)(4)20	4.4	6.0	500	N/A	
20	22	D/7343-31	T496D226M020(2)H4095	4.4	6.0	1000	04053-062(2)	
20	33	X/7343-43	T496X336(1)020(2)(3)(4)10	6.6	6.0	900	N/A	
20	33	X/7343-43	T496X336(1)020(2)(3)(4)20	6.6	6.0	400	N/A	
20	33	X/7343-43	T496X336M020(2)H4095	6.6	6.0	900	04053-063(2)	
20	33	D/7343-31	T496D336(1)020(2)(3)(4)10	6.6	6.0	400	N/A	
20	47	X/7343-43	T496X476(1)020(2)(3)(4)10	9.4	6.0	300	N/A	
20	47	X/7343-43	T496X476M020(2)H4095	9.4	6.0	300	04053-064(2)	
20	47	D/7343-31	T496D476(1)020(2)(3)(4)10	9.4	6.0	300	N/A	
25	0.68	B/3528-21	T496B684(1)025(2)(3)(4)10	0.2	4.0	6500	N/A	
25	0.68	B/3528-21	T496B684M025(2)H4095	0.2	4.0	6500	04053-065(2)	
25	1	B/3528-21	T496B105(1)025(2)(3)(4)10	0.3	4.0	5000	N/A	
25	1	B/3528-21	T496B105(1)025(2)(3)(4)20	0.3	4.0	3500	N/A	
25	1	B/3528-21	T496B105M025(2)H4095	0.3	4.0	5000	04053-066(2)	
25	1.5	B/3528-21	T496B155(1)025(2)(3)(4)10	0.4	6.0	5000	N/A	
25	1.5	B/3528-21	T496B155(1)025(2)(3)(4)20	0.4	6.0	1600	N/A	
25	1.5	B/3528-21	T496B155M025(2)H4095	0.4	6.0	5000	04053-067(2)	
25	2.2	C/6032-28	T496C225(1)025(2)(3)(4)10	0.6	6.0	3500	N/A	
25	2.2	C/6032-28	T496C225M025(2)H4095	0.6	6.0	3500	04053-068(2)	
25	3.3	C/6032-28	T496C335(1)025(2)(3)(4)10	0.8	6.0	2500	N/A	
25	3.3	C/6032-28	T496C335(1)025(2)(3)(4)20	0.8	6.0	2100	N/A	
VDC @ 85°C	µF	KEMET/EIA	(See below for part options)	µA @ +20°C Maximum/ 5 Minutes	% @ +20°C 120 Hz Maximum	mΩ @ +20°C 100 kHz Maximum	Drawing Number	°C
Rated Voltage	Rated Capacitance	Case Code/ Case Size	KEMET Part Number	DC Leakage	DF	ESR	DLA (DSCC)	Maximum Operating Temp

(1) To complete KEMET part number, insert M for ±20% or K for ±10%. Designates Capacitance tolerance.

(2) To complete KEMET part number, insert B (0.1%/1,000 hours), C (0.01%/1,000 hours), D (0.001%/1,000 hours), or A (Non-Weibull Graded).

(3) To complete KEMET part number, insert C = Hot Solder Dipped, H = Solder Plated, K = Solder Fused, or T = 100% Tin (Sn). Designates Termination Finish.

(4) To complete KEMET part number, insert 61 = No Surge, 62 = 10 cycles Surge +25°C, 63 = 10 cycles Surge -55°C and +85°C after Weibull or 64 = 10 cycles Surge -55°C and +85°C before Weibull; N/A for DLA (DSCC) 04053 product - 4095 applies.

Table 1 – Ratings & Part Number Reference cont'd

Rated Voltage	Rated Capacitance	Case Code/ Case Size	KEMET Part Number	DC Leakage	DF	ESR	DLA (DSCC)	Maximum Operating Temp
VDC @ 85°C	µF	KEMET/EIA	(See below for part options)	µA @ +20°C Maximum/ 5 Minutes	% @ +20°C 120 Hz Maximum	mΩ @ +20°C 100 kHz Maximum	Drawing Number	°C
25	3.3	C/6032-28	T496C335M025(2)H4095	0.8	6.0	2500	04053-069(2)	
25	4.7	B/3528-21	T496B475(1)025(2)(3)(4)10	1.2	6.0	4000	N/A	
25	4.7	C/6032-28	T496C475(1)025(2)(3)(4)10	1.2	6.0	2500	N/A	
25	4.7	C/6032-28	T496C475(1)025(2)(3)(4)20	1.2	6.0	1300	N/A	
25	4.7	C/6032-28	T496C475M025(2)H4095	1.2	6.0	2500	04053-070(2)	
25	6.8	C/6032-28	T496C685(1)025(2)(3)(4)10	1.7	6.0	2000	N/A	
25	6.8	C/6032-28	T496C685(1)025(2)(3)(4)20	1.7	6.0	600	N/A	
25	6.8	C/6032-28	T496C685M025(2)H4095	1.7	6.0	2000	04053-071(2)	
25	10	C/6032-28	T496C106(1)025(2)(3)(4)10	2.5	6.0	600	N/A	
25	10	C/6032-28	T496C106M025(2)H4095	2.5	6.0	600	04053-072(2)	
25	10	D/7343-31	T496D106(1)025(2)(3)(4)10	2.5	6.0	1200	N/A	
25	10	D/7343-31	T496D106(1)025(2)(3)(4)20	2.5	6.0	600	N/A	
25	10	D/7343-31	T496D106M025(2)H4095	2.5	6.0	1200	04053-073(2)	
25	15	C/6032-28	T496C156(1)025(2)(3)(4)10	3.8	6.0	750	N/A	
25	15	D/7343-31	T496D156(1)025(2)(3)(4)10	3.8	6.0	1000	N/A	
25	15	D/7343-31	T496D156(1)025(2)(3)(4)20	3.8	6.0	500	N/A	
25	15	D/7343-31	T496D156M025(2)H4095	3.8	6.0	1000	04053-074(2)	
25	22	X/7343-43	T496X226(1)025(2)(3)(4)10	5.5	6.0	900	N/A	
25	22	X/7343-43	T496X226(1)025(2)(3)(4)20	5.5	6.0	400	N/A	
25	22	X/7343-43	T496X226M025(2)H4095	5.5	6.0	900	04053-075(2)	
25	22	D/7343-31	T496D226(1)025(2)(3)(4)10	5.5	6.0	800	N/A	
25	22	D/7343-31	T496D226(1)025(2)(3)(4)20	5.5	6.0	400	N/A	
25	22	D/7343-31	T496D226M025(2)H4095	5.5	6.0	800	04053-076(2)	
35	0.47	B/3528-21	T496B474(1)035(2)(3)(4)10	0.2	4.0	8000	N/A	
35	0.47	B/3528-21	T496B474(1)035(2)(3)(4)20	0.2	4.0	2600	N/A	
35	0.47	B/3528-21	T496B474M035(2)H4095	0.2	4.0	8000	04053-077(2)	
35	0.68	B/3528-21	T496B684(1)035(2)(3)(4)10	0.2	4.0	6500	N/A	
35	0.68	B/3528-21	T496B684M035(2)H4095	0.2	4.0	6500	04053-078(2)	
35	1	B/3528-21	T496B105(1)035(2)(3)(4)10	0.4	4.0	5000	N/A	
35	1	B/3528-21	T496B105(1)035(2)(3)(4)20	0.4	4.0	3100	N/A	
35	1	B/3528-21	T496B105M035(2)H4095	0.4	4.0	5000	04053-079(2)	
35	1.5	C/6032-28	T496C155(1)035(2)(3)(4)10	0.5	6.0	4500	N/A	
35	1.5	C/6032-28	T496C155(1)035(2)(3)(4)20	0.5	6.0	2600	N/A	
35	1.5	C/6032-28	T496C155M035(2)H4095	0.5	6.0	4500	04053-080(2)	
35	2.2	C/6032-28	T496C225(1)035(2)(3)(4)10	0.8	6.0	3500	N/A	
35	2.2	C/6032-28	T496C225(1)035(2)(3)(4)20	0.8	6.0	1600	N/A	
35	2.2	C/6032-28	T496C225M035(2)H4095	0.8	6.0	3500	04053-081(2)	
35	3.3	C/6032-28	T496C335(1)035(2)(3)(4)10	1.2	6.0	2500	N/A	
35	3.3	C/6032-28	T496C335(1)035(2)(3)(4)20	1.2	6.0	900	N/A	
35	3.3	C/6032-28	T496C335M035(2)H4095	1.2	6.0	2500	04053-082(2)	
35	4.7	D/7343-31	T496D475(1)035(2)(3)(4)10	1.6	6.0	1500	N/A	
35	4.7	D/7343-31	T496D475(1)035(2)(3)(4)20	1.6	6.0	700	N/A	
35	4.7	D/7343-31	T496D475M035(2)H4095	1.6	6.0	1500	04053-083(2)	
35	6.8	D/7343-31	T496D685(1)035(2)(3)(4)10	2.4	6.0	1300	N/A	
35	6.8	D/7343-31	T496D685(1)035(2)(3)(4)20	2.4	6.0	750	N/A	
35	6.8	D/7343-31	T496D685M035(2)H4095	2.4	6.0	1300	04053-084(2)	
35	10	X/7343-43	T496X106(1)035(2)(3)(4)10	3.5	6.0	1000	N/A	
VDC @ 85°C	µF	KEMET/EIA	(See below for part options)	µA @ +20°C Maximum/ 5 Minutes	% @ +20°C 120 Hz Maximum	mΩ @ +20°C 100 kHz Maximum	Drawing Number	°C
Rated Voltage	Rated Capacitance	Case Code/ Case Size	KEMET Part Number	DC Leakage	DF	ESR	DLA (DSCC)	Maximum Operating Temp

(1) To complete KEMET part number, insert M for ±20% or K for ±10%. Designates Capacitance tolerance.

(2) To complete KEMET part number, insert B (0.1%/1,000 hours), C (0.01%/1,000 hours), D (0.001%/1,000 hours), or A (Non-Weibull Graded).

(3) To complete KEMET part number, insert C = Hot Solder Dipped, H = Solder Plated, K = Solder Fused, or T = 100% Tin (Sn). Designates Termination Finish.

(4) To complete KEMET part number, insert 61 = No Surge, 62 = 10 cycles Surge +25°C, 63 = 10 cycles Surge -55°C and +85°C after Weibull or 64 = 10 cycles Surge -55°C and +85°C before Weibull; N/A for DLA (DSCC) 04053 product - 4095 applies.

Table 1 – Ratings & Part Number Reference cont'd

Rated Voltage	Rated Capacitance	Case Code/ Case Size	KEMET Part Number	DC Leakage	DF	ESR	DLA (DSCC)	Maximum Operating Temp
VDC @ 85°C	µF	KEMET/EIA	(See below for part options)	µA @ +20°C Maximum/ 5 Minutes	% @ +20°C 120 Hz Maximum	mΩ @ +20°C 100 kHz Maximum	Drawing Number	°C
35	10	X/7343-43	T496X106(1)035(2)(3)(4)20	3.5	6.0	500	N/A	
35	10	X/7343-43	T496X106M035(2)H4095	3.5	6.0	1000	04053-085(2)	
35	10	D/7343-31	T496D106(1)035(2)(3)(4)10	3.5	6.0	400	N/A	
35	15	X/7343-43	T496X156(1)035(2)(3)(4)10	5.3	6.0	900	N/A	
35	15	X/7343-43	T496X156(1)035(2)(3)(4)20	5.3	6.0	500	N/A	
35	15	X/7343-43	T496X156M035(2)H4095	5.3	6.0	900	04053-086(2)	
35	15	D/7343-31	T496D156(1)035(2)(3)(4)10	5.3	6.0	500	N/A	
35	22	X/7343-43	T496X226(1)035(2)(3)(4)10	7.7	6.0	300	N/A	
35	22	X/7343-43	T496X226M035(2)H4095	7.7	6.0	300	04053-087(2)	
50	0.15	B/3528-21	T496B154(1)050(2)(3)(4)10	0.1	4.0	16000	N/A	
50	0.15	B/3528-21	T496B154M050(2)H4095	0.1	4.0	16000	04053-088(2)	
50	0.22	B/3528-21	T496B224(1)050(2)(3)(4)10	0.1	4.0	14000	N/A	
50	0.22	B/3528-21	T496B224(1)050(2)(3)(4)20	0.1	4.0	10000	N/A	
50	0.22	B/3528-21	T496B224M050(2)H4095	0.1	4.0	14000	04053-089(2)	
50	0.33	B/3528-21	T496B334(1)050(2)(3)(4)10	0.2	4.0	10000	N/A	
50	0.33	B/3528-21	T496B334(1)050(2)(3)(4)20	0.2	4.0	2600	N/A	
50	0.33	B/3528-21	T496B334M050(2)H4095	0.2	4.0	10000	04053-090(2)	
50	0.47	C/6032-28	T496C474(1)050(2)(3)(4)10	0.2	4.0	8000	N/A	
50	0.47	C/6032-28	T496C474(1)050(2)(3)(4)20	0.2	4.0	1900	N/A	
50	0.47	C/6032-28	T496C474M050(2)H4095	0.2	4.0	8000	04053-091(2)	
50	0.68	C/6032-28	T496C684(1)050(2)(3)(4)10	0.3	4.0	7000	N/A	
50	0.68	C/6032-28	T496C684(1)050(2)(3)(4)20	0.3	4.0	1700	N/A	
50	0.68	C/6032-28	T496C684M050(2)H4095	0.3	4.0	7000	04053-092(2)	
50	1	C/6032-28	T496C105(1)050(2)(3)(4)10	0.5	4.0	5500	N/A	
50	1	C/6032-28	T496C105(1)050(2)(3)(4)20	0.5	4.0	2700	N/A	
50	1	C/6032-28	T496C105M050(2)H4095	0.5	4.0	5500	04053-093(2)	
50	1.5	C/6032-28	T496C155(1)050(2)(3)(4)10	0.8	6.0	5000	N/A	
50	1.5	C/6032-28	T496C155(1)050(2)(3)(4)20	0.8	6.0	2000	N/A	
50	1.5	C/6032-28	T496C155M050(2)H4095	0.8	6.0	5000	04053-094(2)	
50	2.2	D/7343-31	T496D225(1)050(2)(3)(4)10	1.1	6.0	2500	N/A	
50	2.2	D/7343-31	T496D225(1)050(2)(3)(4)20	1.1	6.0	900	N/A	
50	2.2	D/7343-31	T496D225M050(2)H4095	1.1	6.0	2500	04053-095(2)	
50	3.3	D/7343-31	T496D335(1)050(2)(3)(4)10	1.7	6.0	2000	N/A	
50	3.3	D/7343-31	T496D335(1)050(2)(3)(4)20	1.7	6.0	1000	N/A	
50	3.3	D/7343-31	T496D335M050(2)H4095	1.7	6.0	2000	04053-096(2)	
50	4.7	X/7343-43	T496X475(1)050(2)(3)(4)10	2.4	6.0	1500	N/A	
50	4.7	X/7343-43	T496X475(1)050(2)(3)(4)20	2.4	6.0	400	N/A	
50	4.7	D/7343-31	T496D475(1)050(2)(3)(4)10	2.4	6.0	1500	N/A	
VDC @ 85°C	µF	KEMET/EIA	(See below for part options)	µA @ +20°C Maximum/ 5 Minutes	% @ +20°C 120 Hz Maximum	mΩ @ +20°C 100 kHz Maximum	Drawing Number	°C
Rated Voltage	Rated Capacitance	Case Code/ Case Size	KEMET Part Number	DC Leakage	DF	ESR	DLA (DSCC)	Maximum Operating Temp

(1) To complete KEMET part number, insert M for ±20% or K for ±10%. Designates Capacitance tolerance.

(2) To complete KEMET part number, insert B (0.1%/1,000 hours), C (0.01%/1,000 hours), D (0.001%/1,000 hours), or A (Non-Weibull Graded).

(3) To complete KEMET part number, insert C = Hot Solder Dipped, H = Solder Plated, K = Solder Fused, or T = 100% Tin (Sn). Designates Termination Finish.

(4) To complete KEMET part number, insert 61 = No Surge, 62 = 10 cycles Surge +25°C, 63 = 10 cycles Surge -55°C and +85°C after Weibull or 64 = 10 cycles Surge -55°C and +85°C before Weibull; N/A for DLA (DSCC) 04053 product - 4095 applies.

Recommended Voltage Derating Guidelines

	-55°C to 85°C	85°C to 125°C
% Change in Working DC Voltage with Temperature	V _R	67% of V _R
Recommended Maximum Application Voltage	50% of V _R	33% of V _R

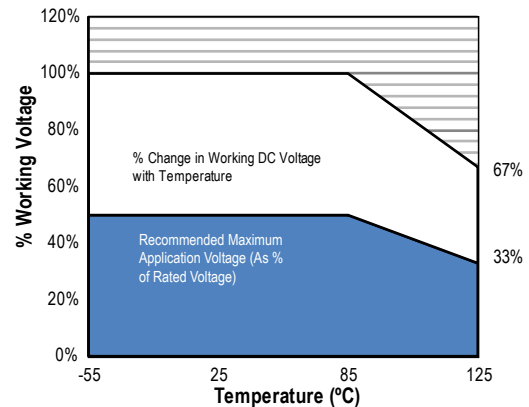

Ripple Current/Ripple Voltage

Permissible AC ripple voltage and current are related to equivalent series resistance (ESR) and the power dissipation capabilities of the device. Permissible AC ripple voltage which may be applied is limited by two criteria:

1. The positive peak AC voltage plus the DC bias voltage, if any, must not exceed the DC voltage rating of the capacitor.
2. The negative peak AC voltage in combination with bias voltage, if any, must not exceed the allowable limits specified for reverse voltage. See the Reverse Voltage section for allowable limits.

The maximum power dissipation by case size can be determined using the table at right. The maximum power dissipation rating stated in the table must be reduced with increasing environmental operating temperatures. Refer to the table below for temperature compensation requirements.

KEMET Case Code	EIA Case Code	Maximum Power Dissipation (P max) mWatts @ 25°C w/+20°C Rise
A	3216-18	75
B	3528-21	85
C	6032-28	110
D	7343-31	150
X	7343-43	165
E	7360-38	200
S	3216-12	60
T	3528-12	70
U	6032-15	90
V	7343-20	125
T510X	7343-43	270
T510E	7360-38	285

The maximum power dissipation rating must be reduced with increasing environmental operating temperatures. Refer to the Temperature Compensation Multiplier table for details.

Temperature Compensation Multipliers for Maximum Ripple Current		
T ≤ 25°C	T ≤ 85°C	T ≤ 125°C
1.00	0.90	0.40

T = Environmental Temperature

Using the P max of the device, the maximum allowable rms ripple current or voltage may be determined.

$$I(max) = \sqrt{P_{max}/R}$$

$$E(max) = Z \sqrt{P_{max}/R}$$

I = rms ripple current (amperes)

R = ESR at specified frequency (ohms)

E = rms ripple voltage (volts)

Z = Impedance at specified frequency (ohms)

P max = maximum power dissipation (watts)

Reverse Voltage

Solid tantalum capacitors are polar devices and may be permanently damaged or destroyed if connected with the wrong polarity. The positive terminal is identified on the capacitor body by a stripe plus in some cases a beveled edge. A small degree of transient reverse voltage is permissible for short periods per the table. The capacitors should not be operated continuously in reverse mode, even within these limits.

Temperature	Permissible Transient Reverse Voltage
25°C	15% of Rated Voltage
85°C	5% of Rated Voltage
125°C	1% of Rated Voltage

Table 2 – Land Dimensions/Courtyard

KEMET Case	Metric Size Code EIA	Density Level A: Maximum (Most) Land Protrusion (mm)					Density Level B: Median (Nominal) Land Protrusion (mm)					Density Level C: Minimum (Least) Land Protrusion (mm)				
		W	L	S	V1	V2	W	L	S	V1	V2	W	L	S	V1	V2
A	3216-18	1.35	2.20	0.62	6.02	2.80	1.23	1.80	0.82	4.92	2.30	1.13	1.42	0.98	4.06	2.04
B	3528-21	2.35	2.21	0.92	6.32	4.00	2.23	1.80	1.12	5.22	3.50	2.13	1.42	1.28	4.36	3.24
C	6032-25	2.35	2.77	2.37	8.92	4.50	2.23	2.37	2.57	7.82	4.00	2.13	1.99	2.73	6.96	3.74
D	7343-31	2.55	2.77	3.67	10.22	5.60	2.43	2.37	3.87	9.12	5.10	2.33	1.99	4.03	8.26	4.84
L	6032-19	2.35	2.77	2.37	8.92	4.50	2.23	2.37	2.57	7.82	4.00	2.13	1.99	2.73	6.96	3.74
M	3528-15	2.35	2.20	0.92	6.32	4.00	2.23	1.80	1.12	5.22	3.50	2.13	1.42	1.28	4.36	3.24
H	7360-20	4.25	2.77	3.67	10.22	7.30	4.13	2.37	3.87	9.12	6.80	4.03	1.99	4.03	8.26	6.54
E ¹	7360-38	4.25	2.77	3.67	10.22	7.30	4.13	2.37	3.87	9.12	6.80	4.03	1.99	4.03	8.26	6.54
Q	7343-12	2.55	2.77	3.67	10.22	5.60	2.43	2.37	3.87	9.12	5.10	2.33	1.99	4.03	8.26	4.84
R ²	2012-12	1.05	1.83	0.15	4.82	2.50	0.93	1.50	0.22	3.72	2.00	0.83	1.12	0.38	2.86	1.74
S ²	3216-12	1.35	2.20	0.62	6.02	2.80	1.23	1.80	0.82	4.92	2.30	1.13	1.42	0.98	4.06	2.04
T	3528-12	2.35	2.20	0.92	6.32	4.00	2.23	1.80	1.12	5.22	3.50	2.13	1.42	1.28	4.36	3.24
U	6032-15	2.35	2.77	2.37	8.92	4.50	2.23	2.37	2.57	7.82	4.00	2.13	1.99	2.73	6.96	3.74
V	7343-20	2.55	2.77	3.67	10.22	5.60	2.43	2.37	3.87	9.12	5.10	2.33	1.99	4.03	8.26	4.84
W	7343-15	2.55	2.77	3.67	10.22	5.60	2.43	2.37	3.87	9.12	5.10	2.33	1.99	4.03	8.26	4.84
X ¹	7343-43	2.55	2.77	3.67	10.22	5.60	2.43	2.37	3.87	9.12	5.10	2.33	1.99	4.03	8.26	4.84
Y ¹	7343-40	2.55	2.77	3.67	10.22	5.60	2.43	2.37	3.87	9.12	5.10	2.33	1.99	4.03	8.26	4.84

Density Level A: For low-density product applications. Recommended for wave solder applications and provides a wider process window for reflow solder processes.

Density Level B: For products with a moderate level of component density. Provides a robust solder attachment condition for reflow solder processes.

Density Level C: For high component density product applications. Before adapting the minimum land pattern variations the user should perform qualification testing based on the conditions outlined in IPC standard 7351 (IPC-7351).

¹ Height of these chips may create problems in wave soldering.

² Land pattern geometry is too small for silkscreen outline.

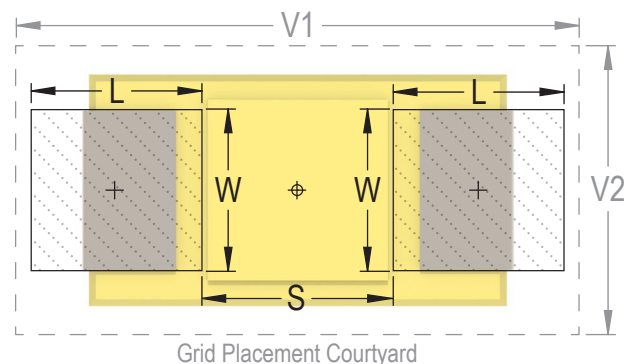

Soldering Process

KEMET's families of surface mount capacitors are compatible with wave (single or dual), convection, IR, or vapor phase reflow techniques. Preheating of these components is recommended to avoid extreme thermal stress. KEMET's recommended profile conditions for convection and IR reflow reflect the profile conditions of the IPC/J-STD-020D standard for moisture sensitivity testing. The devices can safely withstand a maximum of three reflow passes at these conditions.

Please note that although the X/7343-43 case size can withstand wave soldering, the tall profile (4.3 mm maximum) dictates care in wave process development.

Hand soldering should be performed with care due to the difficulty in process control. If performed, care should be taken to avoid contact of the soldering iron to the molded case. The iron should be used to heat the solder pad, applying solder between the pad and the termination, until reflow occurs. Once reflow occurs, the iron should be removed immediately. "Wiping" the edges of a chip and heating the top surface is not recommended.

During typical reflow operations, a slight darkening of the gold-colored epoxy may be observed. This slight darkening is normal and not harmful to the product. Marking permanency is not affected by this change.

Profile Feature	SnPb Assembly	Pb-Free Assembly
Preheat/Soak		
Temperature Minimum (T_{Smin})	100°C	150°C
Temperature Maximum (T_{Smax})	150°C	200°C
Time (t_s) from T_{Smin} to T_{Smax}	60 – 120 seconds	60 – 120 seconds
Ramp-up Rate (T_L to T_p)	3°C/seconds maximum	3°C/seconds maximum
Liquidous Temperature (T_L)	183°C	217°C
Time Above Liquidous (t_L)	60 – 150 seconds	60 – 150 seconds
Peak Temperature (T_p)	220°C* 235°C**	250°C* 260°C**
Time within 5°C of Maximum Peak Temperature (t_p)	20 seconds maximum	30 seconds maximum
Ramp-down Rate (T_p to T_L)	6°C/seconds maximum	6°C/seconds maximum
Time 25°C to Peak Temperature	6 minutes maximum	8 minutes maximum

Note: All temperatures refer to the center of the package, measured on the package body surface that is facing up during assembly reflow.

*Case Size D, E, P, Y, and X

**Case Size A, B, C, H, I, K, M, R, S, T, U, V, W, and Z

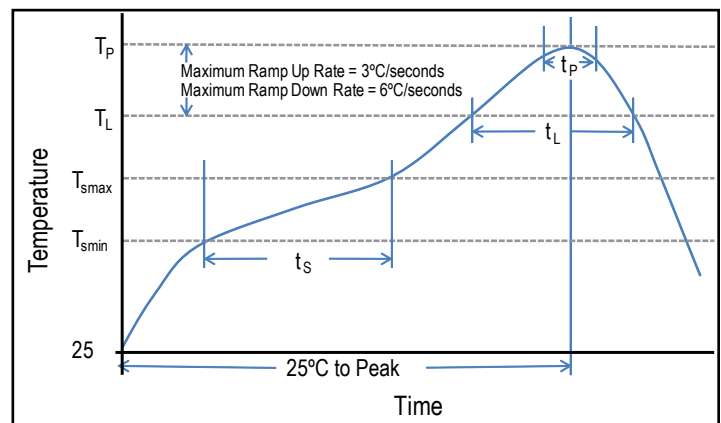

Storage

Tantalum chip capacitors should be stored in normal working environments. While the chips themselves are quite robust in other environments, solderability will be degraded by exposure to high temperatures, high humidity, corrosive atmospheres, and long term storage. In addition, packaging materials will be degraded by high temperature— reels may soften or warp and tape peel force may increase. KEMET recommends that maximum storage temperature not exceed 40°C and maximum storage humidity not exceed 60% relative humidity. Temperature fluctuations should be minimized to avoid condensation on the parts and atmospheres should be free of chlorine and sulphur bearing compounds. For optimized solderability chip stock should be used promptly, preferably within three years of receipt.

Construction

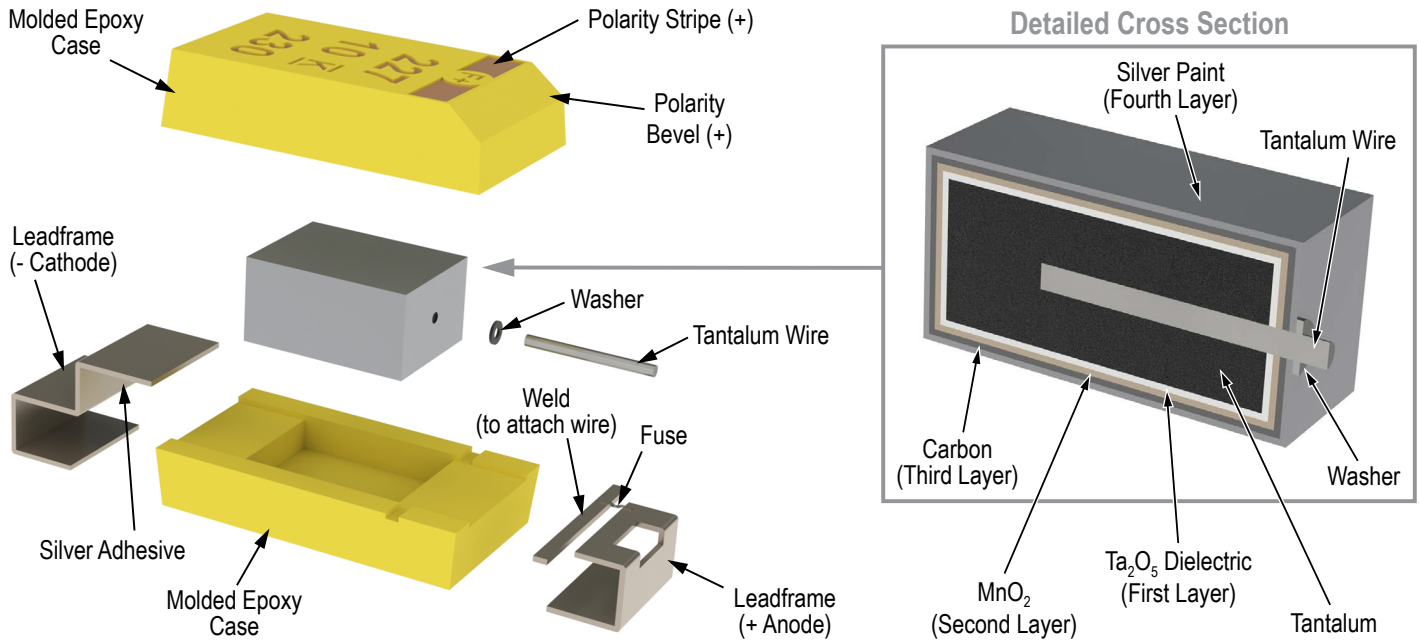

Capacitor Marking

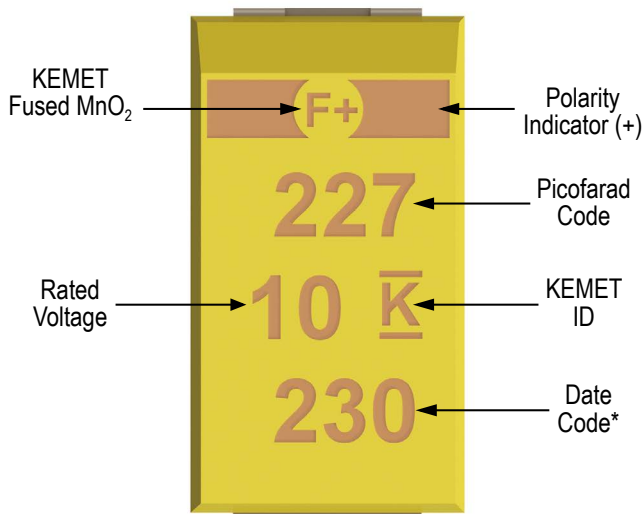

* 230 = 30th week of 2012

Date Code *	
1 st digit = Last number of Year	9 = 2009 0 = 2010 1 = 2011 2 = 2012 3 = 2013 4 = 2014
2 nd and 3 rd digit = Week of the Year	01 = 1 st week of the Year to 52 = 52 nd week of the Year

Tape & Reel Packaging Information

KEMET's molded tantalum and aluminum chip capacitor families are packaged in 8 and 12 mm plastic tape on 7" and 13" reels in accordance with *EIA Standard 481: Embossed Carrier Taping of Surface Mount Components for Automatic Handling*. This packaging system is compatible with all tape-fed automatic pick-and-place systems.

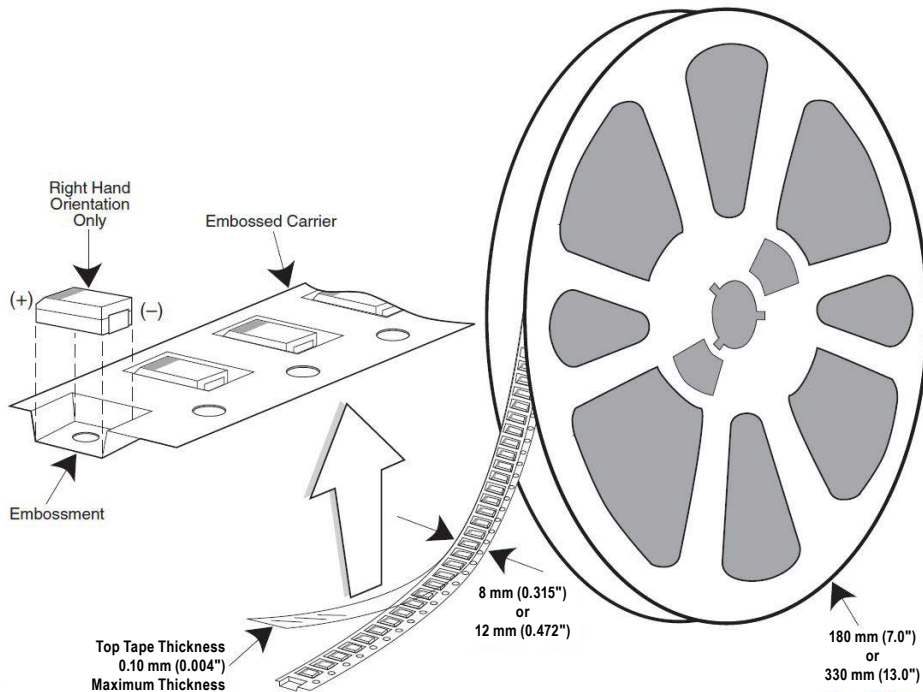

Table 3 – Packaging Quantity

Case Code		Tape Width (mm)	7" Reel*	13" Reel*
KEMET	EIA			
S	3216-12	8	2,500	10,000
T	3528-12	8	2,500	10,000
M	3528-15	8	2,000	8,000
U	6032-15	12	1,000	5,000
L	6032-19	12	1,000	5,000
W	7343-15	12	1,000	3,000
Z	7343-17	12	1,000	3,000
V	7343-20	12	1,000	3,000
A	3216-18	8	2,000	9,000
B	3528-21	8	2,000	8,000
C	6032-28	12	500	3,000
D	7343-31	12	500	2,500
Q	7343-12	12	1,000	3,000
Y	7343-40	12	500	2,000
X	7343-43	12	500	2,000
E/T428P	7360-38	12	500	2,000
H	7360-20	12	1,000	2,500

* No C-Spec required for 7" reel packaging. C-7280 required for 13" reel packaging.

Figure 1 – Embossed (Plastic) Carrier Tape Dimensions

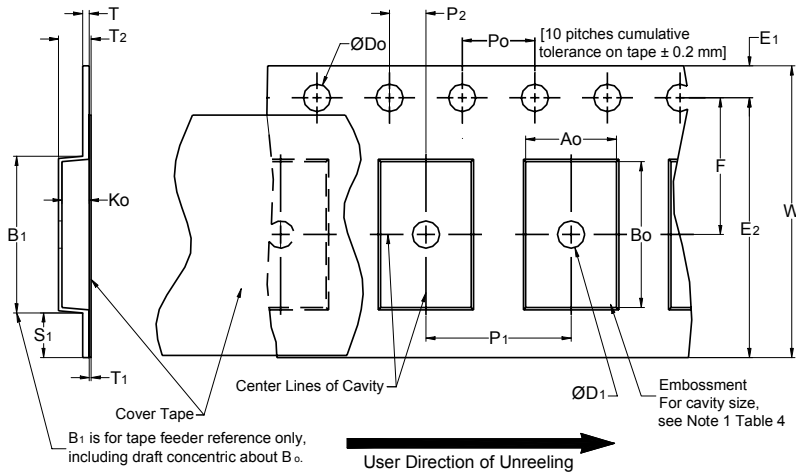

Table 4 – Embossed (Plastic) Carrier Tape Dimensions

Metric will govern

Constant Dimensions — Millimeters (Inches)										
Tape Size	D ₀	D ₁ Minimum Note 1	E ₁	P ₀	P ₂	R Reference Note 2	S ₁ Minimum Note 3	T Maximum	T ₁ Maximum	
8 mm	1.5 +0.10/-0.0 (0.059 +0.004/-0.0)	1.0 (0.039)	1.75 ±0.10 (0.069 ±0.004)	4.0 ±0.10 (0.157 ±0.004)	2.0 ±0.05 (0.079 ±0.002)	25.0 (0.984)	0.600 (0.024)	0.600 (0.024)	0.100 (0.004)	
12 mm		1.5 (0.059)			2.0 ±0.1 (0.079 ±0.059)					30 (1.181)
16 mm										
Variable Dimensions — Millimeters (Inches)										
Tape Size	Pitch	B ₁ Maximum Note 4	E ₂ Minimum	F	P ₁	T ₂ Maximum	W Maximum	A ₀ , B ₀ & K ₀		
8 mm	Single (4 mm)	4.35 (0.171)	6.25 (0.246)	3.5 ±0.05 (0.138 ±0.002)	2.0 ±0.05 or 4.0 ±0.10 (0.079 ±0.002 or 0.157 ±0.004)	2.5 (0.098)	8.3 (0.327)	Note 5		
12 mm	Single (4 mm) & Double (8 mm)	8.2 (0.323)	10.25 (0.404)	5.5 ±0.05 (0.217 ±0.002)	2.0 ±0.05 (0.079 ±0.002) or 4.0 ±0.10 (0.157 ±0.004) or 8.0 ±0.10 (0.315 ±0.004)	4.6 (0.181)	12.3 (0.484)			
16 mm	Triple (12 mm)	12.1 (0.476)	14.25 (0.561)	7.5 ±0.10 (0.295 ±0.004)	4.0 ±0.10 (0.157 ±0.004) to 12.0 ±0.10 (0.472 ±0.004)	8.0 (0.315)	16.3 (0.642)			

- The embossment hole location shall be measured from the sprocket hole controlling the location of the embossment. Dimensions of embossment location and hole location shall be applied independent of each other.
- The tape, with or without components, shall pass around R without damage (see Figure 4).
- If S₁ < 1.0 mm, there may not be enough area for cover tape to be properly applied (see EIA Standard 481–D, paragraph 4.3, section b).
- B₁ dimension is a reference dimension for tape feeder clearance only.
- The cavity defined by A₀, B₀ and K₀ shall surround the component with sufficient clearance that:
 - the component does not protrude above the top surface of the carrier tape.
 - the component can be removed from the cavity in a vertical direction without mechanical restriction, after the top cover tape has been removed.
 - rotation of the component is limited to 20° maximum for 8 and 12 mm tapes and 10° maximum for 16 mm tapes (see Figure 2).
 - lateral movement of the component is restricted to 0.5 mm maximum for 8 mm and 12 mm wide tape and to 1.0 mm maximum for 16 mm tape (see Figure 3).
 - see Addendum in EIA Standard 481–D for standards relating to more precise taping requirements.

Packaging Information Performance Notes

- 1. Cover Tape Break Force:** 1.0 Kg minimum.
- 2. Cover Tape Peel Strength:** The total peel strength of the cover tape from the carrier tape shall be:

Tape Width	Peel Strength
8 mm	0.1 to 1.0 Newton (10 to 100 gf)
12 and 16 mm	0.1 to 1.3 Newton (10 to 130 gf)

The direction of the pull shall be opposite the direction of the carrier tape travel. The pull angle of the carrier tape shall be 165° to 180° from the plane of the carrier tape. During peeling, the carrier and/or cover tape shall be pulled at a velocity of 300 ±10 mm/minute.

- 3. Labeling:** Bar code labeling (standard or custom) shall be on the side of the reel opposite the sprocket holes. Refer to EIA Standards 556 and 624.

Figure 2 – Maximum Component Rotation

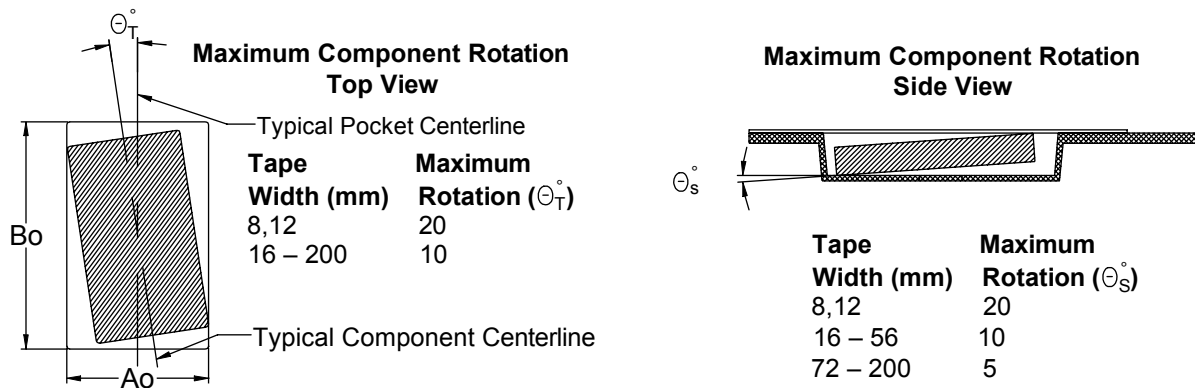

Figure 3 – Maximum Lateral Movement

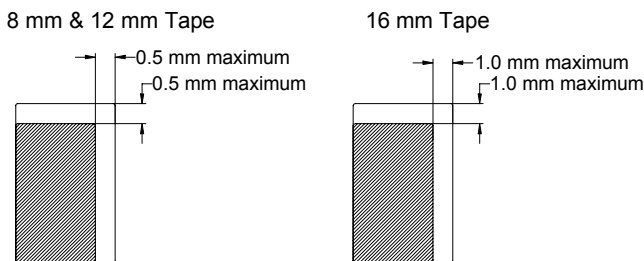

Figure 4 – Bending Radius

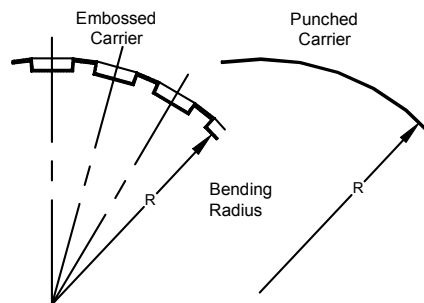

Figure 5 – Reel Dimensions

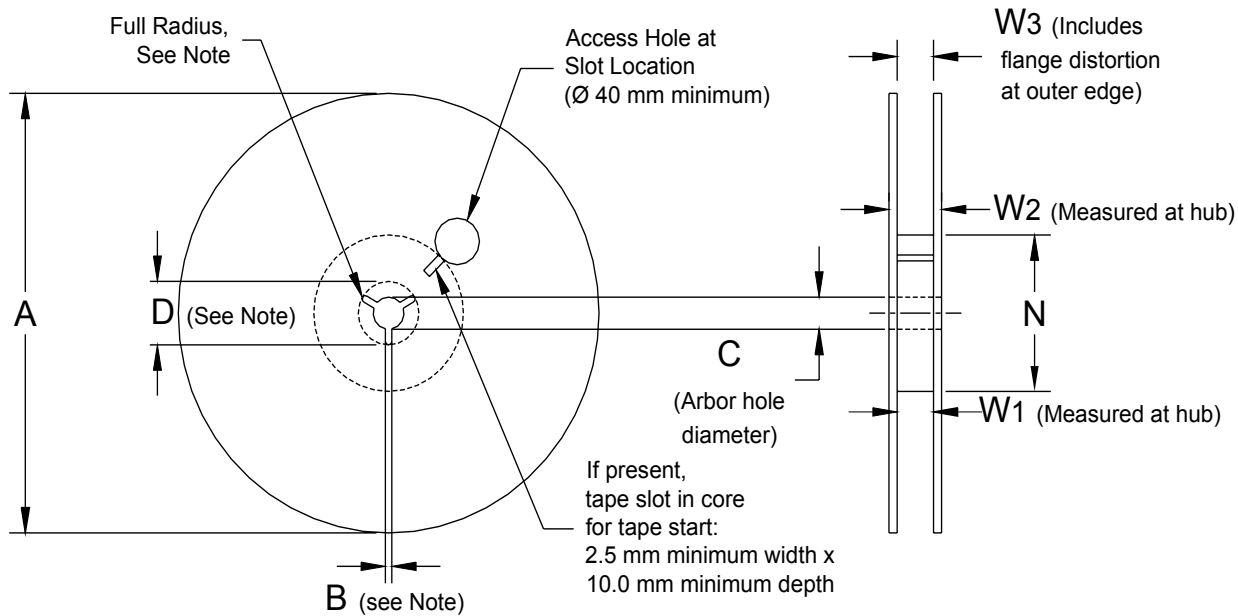

Table 5 – Reel Dimensions

Metric will govern

Constant Dimensions — Millimeters (Inches)				
Tape Size	A	B Minimum	C	D Minimum
8 mm	178 ±0.20 (7.008 ±0.008) or 330 ±0.20 (13.000 ±0.008)	1.5 (0.059)	13.0 +0.5/-0.2 (0.521 +0.02/-0.008)	20.2 (0.795)
12 mm				
16 mm				
Variable Dimensions — Millimeters (Inches)				
Tape Size	N Minimum	W ₁	W ₂ Maximum	W ₃
8 mm	50 (1.969)	8.4 +1.5/-0.0 (0.331 +0.059/-0.0)	14.4 (0.567)	Shall accommodate tape width without interference
12 mm		12.4 +2.0/-0.0 (0.488 +0.078/-0.0)	18.4 (0.724)	
16 mm		16.4 +2.0/-0.0 (0.646 +0.078/-0.0)	22.4 (0.882)	

Figure 6 – Tape Leader & Trailer Dimensions

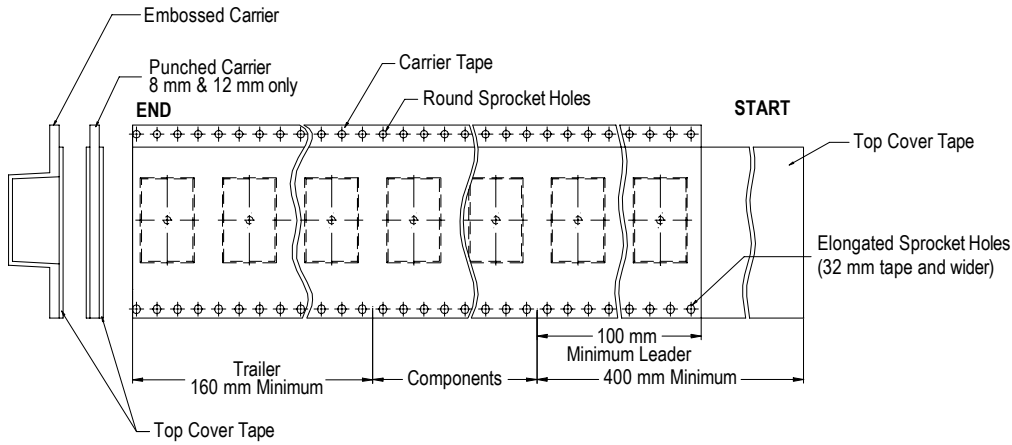
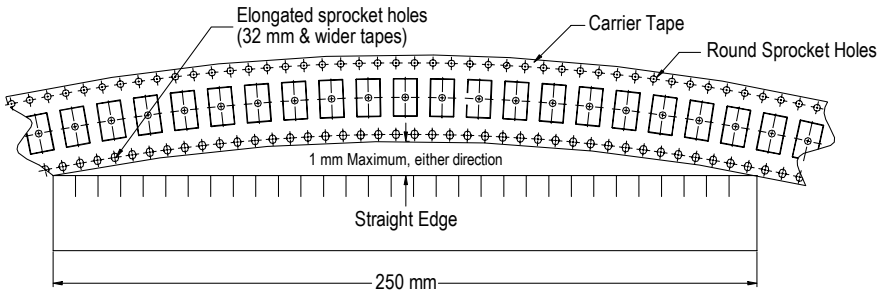

Figure 7 – Maximum Camber



KEMET Corporation World Headquarters

2835 KEMET Way
Simpsonville, SC 29681

Mailing Address:
P.O. Box 5928
Greenville, SC 29606

www.kemet.com
Tel: 864-963-6300
Fax: 864-963-6521

Corporate Offices
Fort Lauderdale, FL
Tel: 954-766-2800

North America

Southeast
Lake Mary, FL
Tel: 407-855-8886

Northeast
Wilmington, MA
Tel: 978-658-1663

Central
Novi, MI
Tel: 248-306-9353

West
Milpitas, CA
Tel: 408-433-9950

Mexico
Guadalajara, Jalisco
Tel: 52-33-3123-2141

Europe

Southern Europe
Paris, France
Tel: 33-1-4646-1006

Sasso Marconi, Italy
Tel: 39-051-939111

Central Europe
Landsberg, Germany
Tel: 49-8191-3350800

Kamen, Germany
Tel: 49-2307-438110

Northern Europe
Bishop's Stortford, United Kingdom
Tel: 44-1279-460122

Espoo, Finland
Tel: 358-9-5406-5000

Asia

Northeast Asia
Hong Kong
Tel: 852-2305-1168

Shenzhen, China
Tel: 86-755-2518-1306

Beijing, China
Tel: 86-10-5829-1711

Shanghai, China
Tel: 86-21-6447-0707

Taipei, Taiwan
Tel: 886-2-27528585

Southeast Asia
Singapore
Tel: 65-6586-1900

Penang, Malaysia
Tel: 60-4-6430200

Bangalore, India
Tel: 91-806-53-76817

Note: KEMET reserves the right to modify minor details of internal and external construction at any time in the interest of product improvement. KEMET does not assume any responsibility for infringement that might result from the use of KEMET Capacitors in potential circuit designs. KEMET is a registered trademark of KEMET Electronics Corporation.

Disclaimer

All product specifications, statements, information and data (collectively, the "Information") in this datasheet are subject to change. The customer is responsible for checking and verifying the extent to which the Information contained in this publication is applicable to an order at the time the order is placed.

All Information given herein is believed to be accurate and reliable, but it is presented without guarantee, warranty, or responsibility of any kind, expressed or implied.

Statements of suitability for certain applications are based on KEMET Electronics Corporation's ("KEMET") knowledge of typical operating conditions for such applications, but are not intended to constitute – and KEMET specifically disclaims – any warranty concerning suitability for a specific customer application or use. The Information is intended for use only by customers who have the requisite experience and capability to determine the correct products for their application. Any technical advice inferred from this Information or otherwise provided by KEMET with reference to the use of KEMET's products is given gratis, and KEMET assumes no obligation or liability for the advice given or results obtained.

Although KEMET designs and manufactures its products to the most stringent quality and safety standards, given the current state of the art, isolated component failures may still occur. Accordingly, customer applications which require a high degree of reliability or safety should employ suitable designs or other safeguards (such as installation of protective circuitry or redundancies) in order to ensure that the failure of an electrical component does not result in a risk of personal injury or property damage.

Although all product-related warnings, cautions and notes must be observed, the customer should not assume that all safety measures are indicated or that other measures may not be required.

Product & Process Design

Sales & Marketing

Supplier

Material Management

Quality

Manufacturing

Logistics & Distribution

People: Leadership
& Development

KEMET Production System

Corporate Office

KEMET Corporation
2835 KEMET Way
Simpsonville, SC 29681
USA

Tel: 864.963.6300

Fax: 864.963.6521

www.kemet.com

One world. One KEMET.

Electronic Components
KEMET
CHARGED®