

HD26LS32A

Quadruple Differential Line Receivers With 3 State Outputs

HITACHI

ADE-205-578 (Z)
1st. Edition
Dec. 2000

Description

The HD26LS32A features quadruple line receivers designed to meet the specs of EIA standard RS-422A and RS-423. This device operates from a single 5 V power supply. The enable function is common to all four receivers and offers a choice of active high or active low input. Fail safe design ensures that if the inputs are open, the outputs will always be high.

Logic Diagram

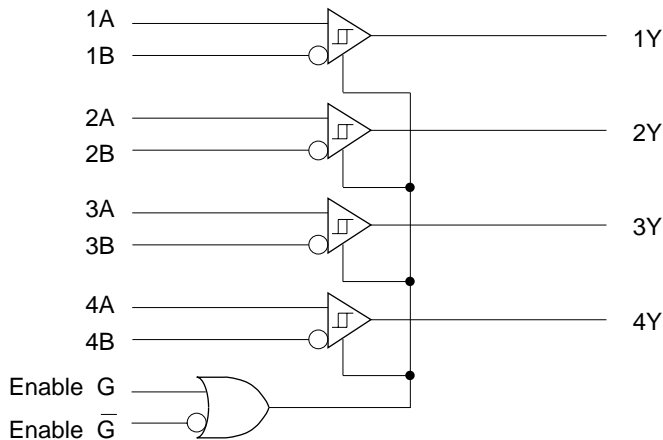

Pin Arrangement

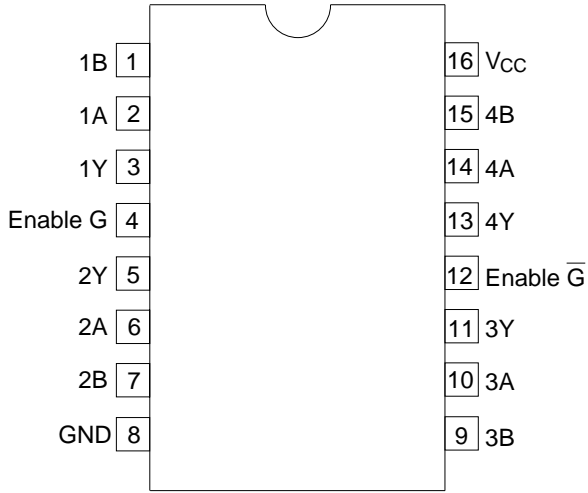

(Top view)

Function Table

Differential Input A – B	Enable		Output Y
	G	Ḡ	
$V_{ID} \geq V_{TH}$	H	X	H
	X	L	H
$V_{TL} < V_{ID} < V_{TH}$	H	X	?
	X	L	?
$V_{ID} \leq V_{TL}$	H	X	L
	X	L	L
X	L	H	Z

H : High level

L : Low level

X : Immaterial

? : Irrelevant

Z : High impedance

Absolute Maximum Ratings

Item	Symbol	Ratings	Unit
Supply Voltage	V_{CC}^{*1}	7.0	V
Input Voltage A or B	V_{IN}	± 25	V
Differential Input Voltage	V_{ID}^{*2}	± 25	V
Enable Input Voltage	V_{IN}	7	V
Output Sink Current	I_{out}	50	mA
Continuous Total Dissipation	P_T	1	W
Operating Temperature	T_{opr}	0 to +70	$^{\circ}C$
Storage Temperature	T_{stg}	-65 to 150	$^{\circ}C$

- Notes: 1. All voltage values except for differential input voltage are with respect to network ground terminal.
2. Differential input voltage is measured at the noninverting input with respect to the corresponding inverting input.
3. The absolute maximum ratings are values which must not individually be exceeded, and furthermore, no two of which may be realized at the same time.

Recommended Operating Conditions

Item	Symbol	Min	Typ	Max	Unit
Supply Voltage	V_{CC}	4.75	5.00	5.25	V
In Phase Input Voltage	V_{IC}	—	—	± 7.0	V
Output Current	I_{OH}	—	—	-440	μA
	I_{OL}	—	—	8	mA
Operating Temperature	T_{opr}	0	—	70	$^{\circ}C$

Electrical Characteristics (Ta = 0 to +70°C)

Item	Symbol	Min	Typ* ¹	Max	Unit	Conditions
Differential Input High Threshold Voltage	V_{TH}	—	—	0.2	V	$V_{IC} = -7$ to $+7$ V $V_{OH} = 2.7$ V, $I_{OH} = -440$ μ A
Differential Input Low Threshold Voltage	V_{TL}	—	—	-0.2		$V_{OL} = 0.4$ V, $I_{OL} = 4$ mA
		—	—	-0.2		$V_{OL} = 0.45$ V, $I_{OL} = 8$ mA
Input Hysteresis* ²	$V_{TH} - V_{TL}$	—	50	—	mV	
Enable Input Voltage	V_{IH}	2.0	—	—	V	
	V_{IL}	—	—	0.8		
Enable Input Clamp Voltage	V_{IK}	—	—	-1.5		$V_{CC} = 4.75$ V, $I_{IN} = -18$ mA
Output Voltage	V_{OH}	2.7	—	—		$V_{CC} = 4.75$ V $V_{ID} = 1$ V, $I_{OH} = -440$ μ A
	V_{OL}	—	—	0.4		$V_{IL} (\bar{G}) = 0.8$ V $V_{ID} = -1$ V, $I_{OL} = 4$ mA
		—	—	0.45		$V_{ID} = -1$ V, $I_{OL} = 8$ mA
Off State (High Impedance) Output Current	I_{OZ}	—	—	20	μ A	$V_{CC} = 5.25$ V $V_O = 2.4$ V
		—	—	-20		$V_O = 0.4$ V
Line Input Current	I_I	—	—	2.3	mA	$V_I = 15$ V, Other Inputs -10 to $+15$ V
		—	—	-2.8		$V_I = -15$ V, Other Inputs -15 to $+10$ V
Enable Input Current	I_I (EN)	—	—	100	μ A	$V_I = 5.5$ V
	I_{IH}	—	—	20		$V_I = 2.7$ V
	I_{IL}	—	—	-0.36	mA	$V_I = 0.4$ V
Input Resistance	r_i	6	9.8	—	k Ω	$V_{IC} = -15$ to $+15$ V (Other Inputs AC GND)
Short Circuit Output Current	I_{OS} * ³	-15	—	-85	mA	$V_{CC} = 5.25$ V
Supply Current	I_{CC}	—	52	70		$V_{CC} = 5.25$ V, $V_I = 0$ V (All Outputs Disable)

Notes: 1. All typical values are at $V_{CC} = 5$ V, $T_a = 25^\circ\text{C}$, $V_{IC} = 0$.

2. Hysteresis is the differential between the positive going input threshold voltage and the negative going input threshold voltage.

3. Not more than one output should be shorted at a time.

Switching Characteristics ($V_{CC} = 5\text{ V}$, $T_a = 25^\circ\text{C}$)

Item	Symbol	Min	Typ	Max	Unit	Conditions
Propagation Delay Time	t_{PLH}	—	20	35	ns	$C_L = 15\text{ pF}$
	t_{PHL}	—	22	35		
Output Enable Time	t_{ZH}	—	17	22	ns	$C_L = 15\text{ pF}$
	t_{ZL}	—	20	25		
Output Disable Time	t_{HZ}	—	21	30	ns	$C_L = 5\text{ pF}$
	t_{LZ}	—	30	40		

1. t_{PLH} , t_{PHL}

Test circuit

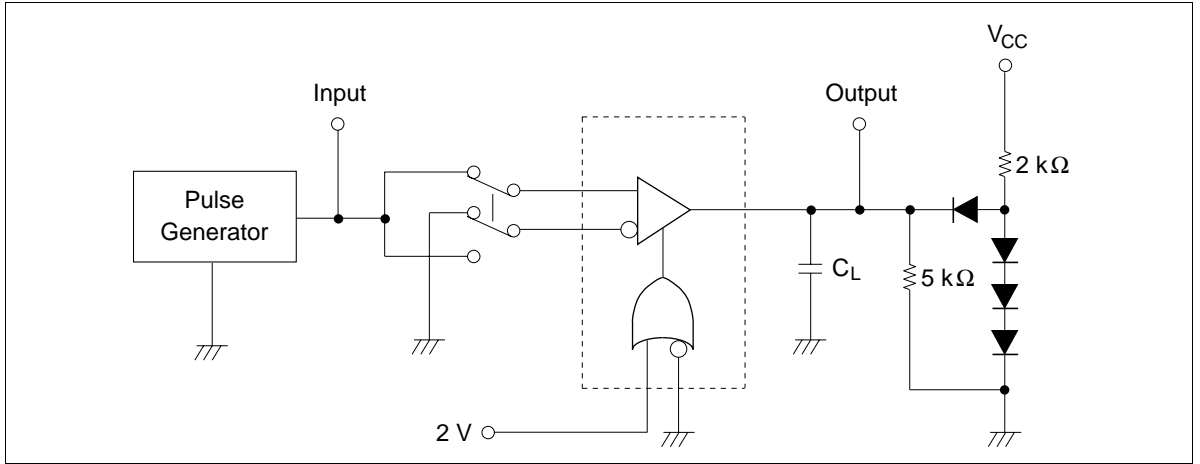

Waveforms

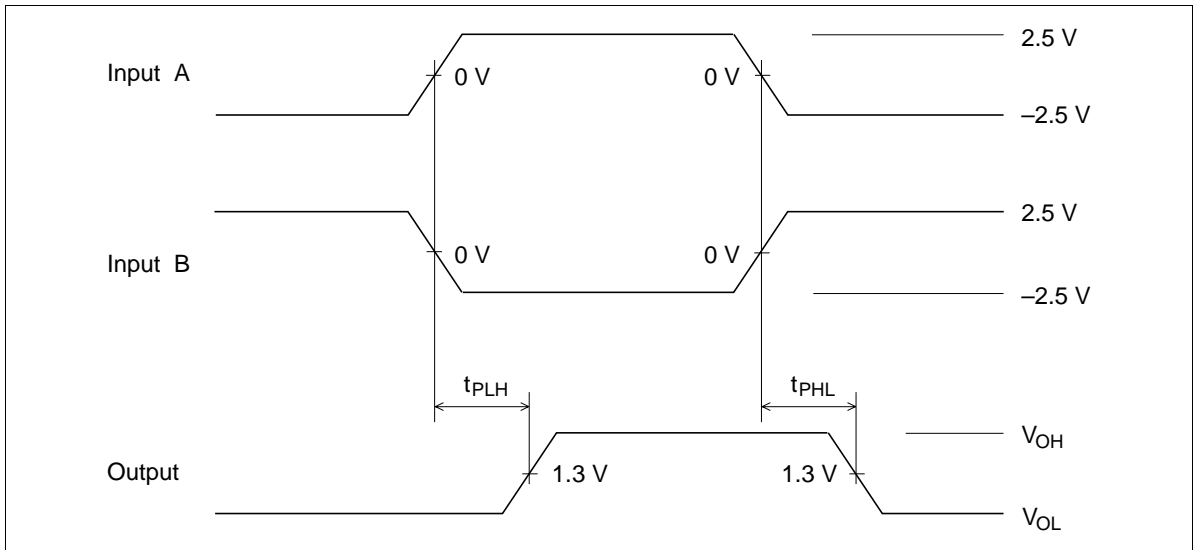

3. t_{LZ} , t_{ZL}

Test circuit

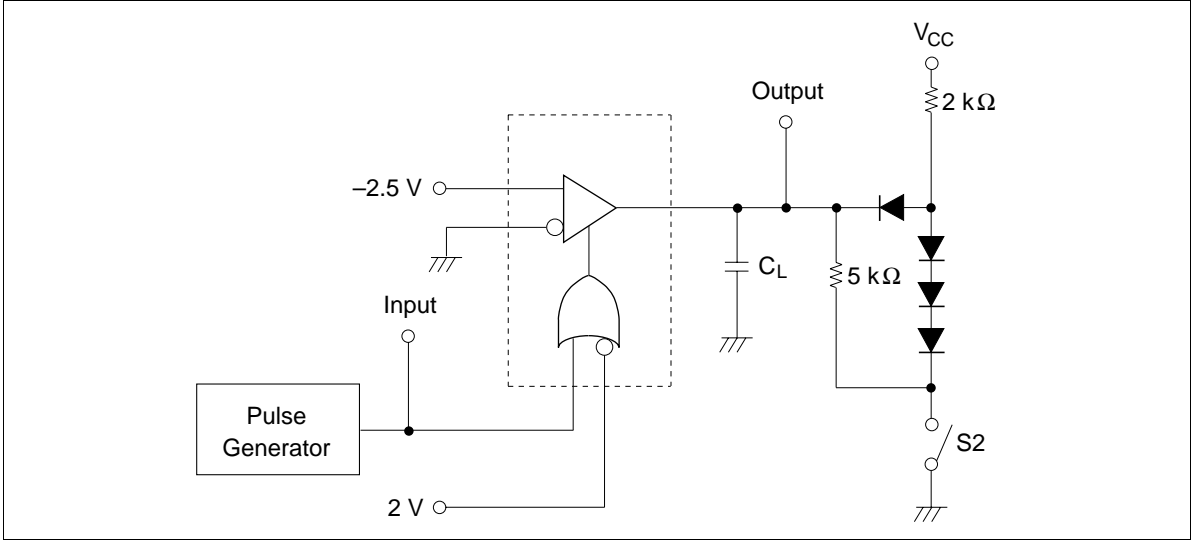

Waveforms

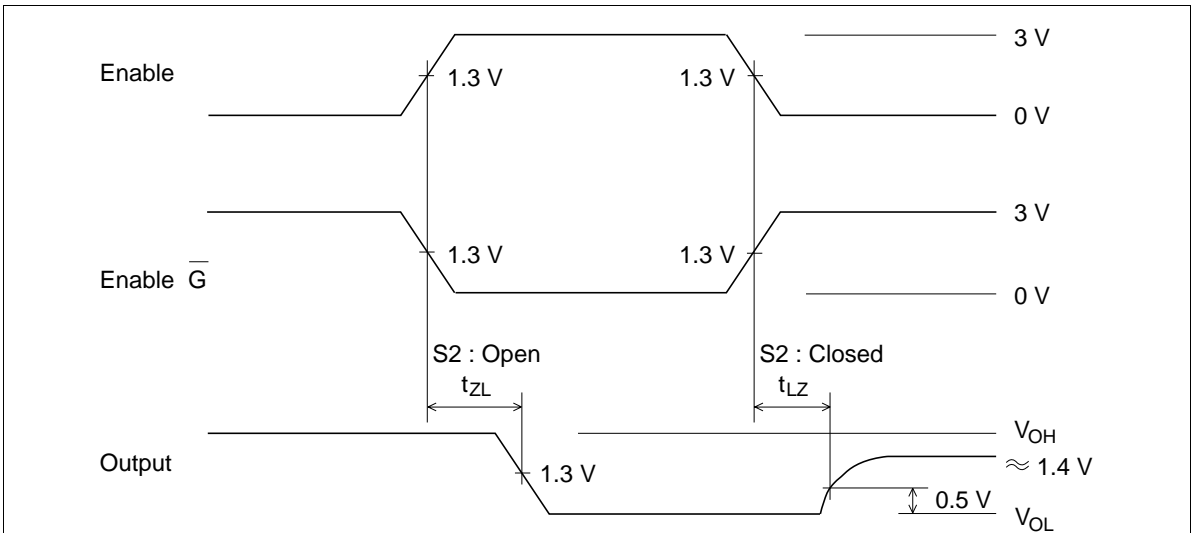

- Notes:
1. The pulse generator has the following characteristics:
 $PRR = 1 \text{ MHz}$, 50% duty cycle, $t_r \leq 6 \text{ ns}$, $t_f \leq 6 \text{ ns}$, $Z_{out} = 50\Omega$.
 2. C_L includes probe and jig capacitance.
 3. All diodes are 1S2074(H).
 4. To test G input, ground G input and apply an inverted input waveform.

Package Dimensions

Unit: mm

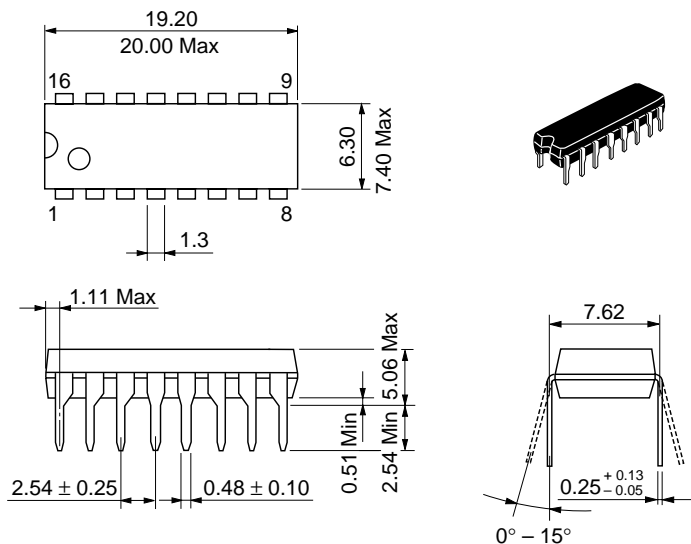

Hitachi Code	DP-16
JEDEC	Conforms
EIAJ	Conforms
Mass (reference value)	1.07 g

Unit: mm

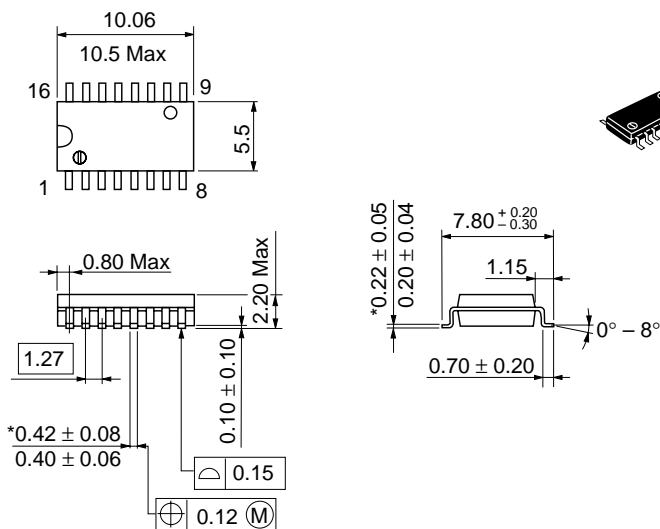

*Dimension including the plating thickness
Base material dimension

Hitachi Code	FP-16DA
JEDEC	—
EIAJ	Conforms
Mass (reference value)	0.24 g

Cautions

1. Hitachi neither warrants nor grants licenses of any rights of Hitachi's or any third party's patent, copyright, trademark, or other intellectual property rights for information contained in this document. Hitachi bears no responsibility for problems that may arise with third party's rights, including intellectual property rights, in connection with use of the information contained in this document.
2. Products and product specifications may be subject to change without notice. Confirm that you have received the latest product standards or specifications before final design, purchase or use.
3. Hitachi makes every attempt to ensure that its products are of high quality and reliability. However, contact Hitachi's sales office before using the product in an application that demands especially high quality and reliability or where its failure or malfunction may directly threaten human life or cause risk of bodily injury, such as aerospace, aeronautics, nuclear power, combustion control, transportation, traffic, safety equipment or medical equipment for life support.
4. Design your application so that the product is used within the ranges guaranteed by Hitachi particularly for maximum rating, operating supply voltage range, heat radiation characteristics, installation conditions and other characteristics. Hitachi bears no responsibility for failure or damage when used beyond the guaranteed ranges. Even within the guaranteed ranges, consider normally foreseeable failure rates or failure modes in semiconductor devices and employ systemic measures such as fail-safes, so that the equipment incorporating Hitachi product does not cause bodily injury, fire or other consequential damage due to operation of the Hitachi product.
5. This product is not designed to be radiation resistant.
6. No one is permitted to reproduce or duplicate, in any form, the whole or part of this document without written approval from Hitachi.
7. Contact Hitachi's sales office for any questions regarding this document or Hitachi semiconductor products.

HITACHI

Hitachi, Ltd.

Semiconductor & Integrated Circuits.
Nippon Bldg., 2-6-2, Ohte-machi, Chiyoda-ku, Tokyo 100-0004, Japan
Tel: Tokyo (03) 3270-2111 Fax: (03) 3270-5109

URL NorthAmerica : <http://semiconductor.hitachi.com/>
 Europe : <http://www.hitachi-eu.com/hel/ecg>
 Asia : <http://sicapac.hitachi-asia.com>
 Japan : <http://www.hitachi.co.jp/Sicd/indx.htm>

For further information write to:

Hitachi Semiconductor
(America) Inc.
179 East Tasman Drive,
San Jose, CA 95134
Tel: <1> (408) 433-1990
Fax: <1>(408) 433-0223

Hitachi Europe GmbH
Electronic Components Group
Dornacher StraÙe 3
D-85622 Feldkirchen, Munich
Germany
Tel: <49> (89) 9 9180-0
Fax: <49> (89) 9 29 30 00

Hitachi Europe Ltd.
Electronic Components Group.
Whitebrook Park
Lower Cookham Road
Maidenhead
Berkshire SL6 8YA, United Kingdom
Tel: <44> (1628) 585000
Fax: <44> (1628) 585160

Hitachi Asia Ltd.
Hitachi Tower
16 Collyer Quay #20-00,
Singapore 049318
Tel: <65>-538-6533/538-8577
Fax: <65>-538-6933/538-3877
URL: <http://www.hitachi.com.sg>

Hitachi Asia Ltd.
(Taipei Branch Office)
4/F, No. 167, Tun Hwa North Road,
Hung-Kuo Building,
Taipei (105), Taiwan
Tel: <886>-(2)-2718-3666
Fax: <886>-(2)-2718-8180
Telex: 23222 HAS-TP
URL: <http://www.hitachi.com.tw>

Hitachi Asia (Hong Kong) Ltd.
Group III (Electronic Components)
7/F., North Tower,
World Finance Centre,
Harbour City, Canton Road
Tsim Sha Tsui, Kowloon,
Hong Kong
Tel: <852>-(2)-735-9218
Fax: <852>-(2)-730-0281
URL: <http://www.hitachi.com.hk>

Copyright © Hitachi, Ltd., 2000. All rights reserved. Printed in Japan.
Colophon 2.0

HITACHI