

# 23–30 GHz GaAs MMIC 4 Port Reflective PIN Switch

AP028R2-00

## Features

- Low Loss
- Excellent Return Loss
- Fast Switching Speed
- High Power Handling

## Description

Skyworks' 4 port PIN diode switch is a robust, high performance switch. It is ideal for low loss, high isolation applications, particularly where high power handling is required. The chip uses Skyworks' proven PIN diode technology, and is based upon MBE layers for the highest uniformity and repeatability. The diodes employ surface passivation to ensure a rugged, reliable part with through-substrate via holes and gold-based backside metallization to facilitate an epoxy die attach process. The GaAs MMIC employs a shunt PIN diode in each arm and an on-chip bias network. Chips are measured on a 100% basis for DC diode breakdown voltage, turn-on voltage and RF parameters on selected paths.

## Chip Outline

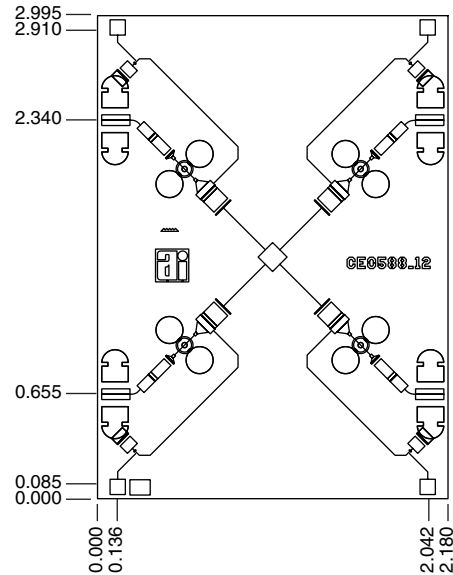

Dimensions indicated in mm.  
All RF pads are 0.07 x 0.150 mm. All DC pads are 0.1 x 0.1 mm.  
Chip thickness = 0.1 mm.

## Absolute Maximum Ratings

Characteristic	Value
Operating Temperature ( $T_C$ )	-55°C to +125°C
Storage Temperature ( $T_{ST}$ )	-65°C to +150°C
DC Reverse Bias	-70 V (-10 $\mu$ A)
DC Forward Bias	1.3 V (50 mA)
$P_{IN}$	10 W

## Electrical Specifications at 25°C

Parameter	Condition	Symbol	Min.	Typ. <sup>2</sup>	Max.	Unit
Insertion Loss	F = 23–30 GHz	IL		1.3	1.9	dB
Isolation	F = 23–30 GHz	Iso	30	34		dB
Input Return Loss	F = 23–30 GHz	RL <sub>I</sub>	12	15		dB
Output Return Loss	F = 23–30 GHz	RL <sub>O</sub>	12	15		dB
Breakdown Voltage	I <sub>R</sub> = 10 $\mu$ A	V <sub>BR</sub>	20	60		V
Forward Voltage	I <sub>F</sub> = 10 mA	V <sub>F</sub>	0.9	1.25	1.3	V
Switching Speed <sup>1</sup>				2		ns
Output Power at 1 dB Compression <sup>1</sup>	F = 23–30 GHz	P <sub>1 dB</sub>		33		dBm
Two-Tone Input Third-Order Intercept <sup>1</sup>	F = 28 GHz	IIP3	45			dBm

1. Not measured on a 100% basis.

2. Typical represents the median parameter value across the specified frequency range for the median chip.

### Typical Performance Data

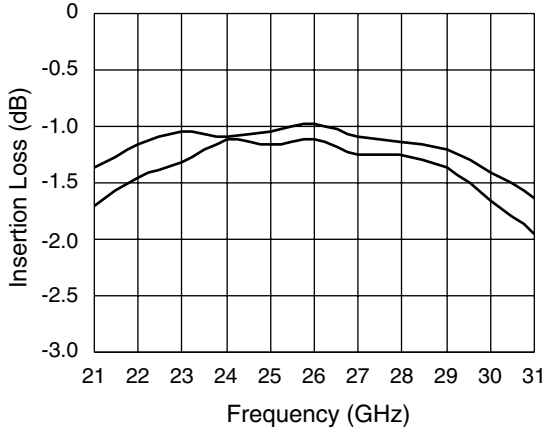

**Insertion Losses for Multiple Paths**  
 Bias Conditions:  $I_F = 10 \text{ mA}$ ,  $V_R = -5 \text{ V}$

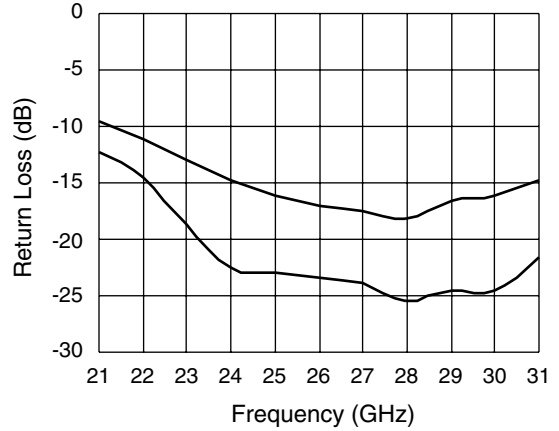

**Return Losses for Multiple Paths**  
 Bias Conditions:  $I_F = 10 \text{ mA}$ ,  $V_R = -5 \text{ V}$

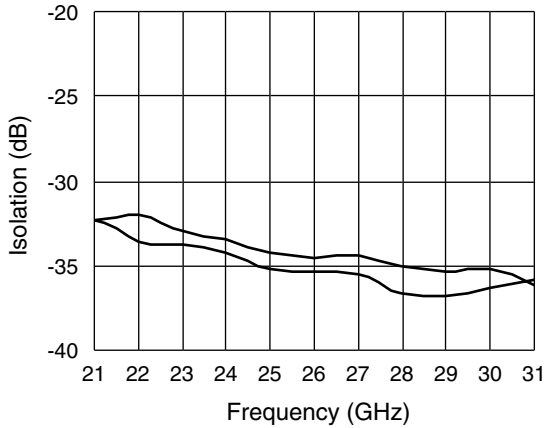

**Isolation for Multiple Paths**  
 Bias Conditions:  $I_F = 10 \text{ mA}$ ,  $V_R = -5 \text{ V}$

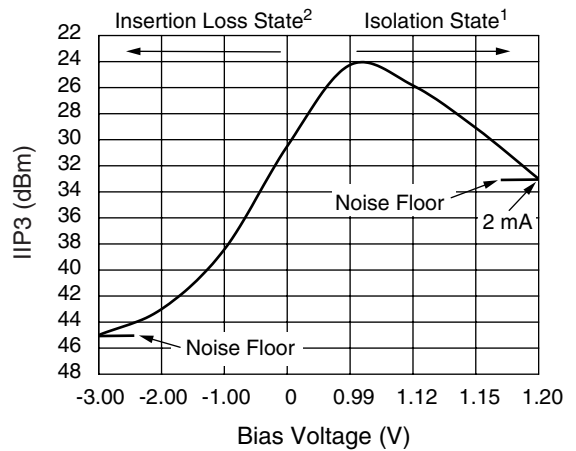

**Two-Tone Input Third-Order Intercept @ 28 GHz**

1. Isolation arms are biased with 10 mA (1.25 V) where IIP3 is below the noise floor.
2. Insertion loss arms are biased with -5 V where IIP3 is below the noise floor.

**Truth Table**

DC1	DC2	DC3	DC4	Insertion Loss Path
-5 V	-5 V	10 mA	10 mA	RF1–RF2
-5 V	10 mA	-5 V	10 mA	RF1–RF3
-5 V	10 mA	10 mA	-5 V	RF1–RF4
10 mA	-5 V	-5 V	10 mA	RF2–RF3
10 mA	-5 V	10 mA	-5 V	RF2–RF4
10 mA	10 mA	-5 V	-5 V	RF3–RF4

**Bias Arrangement**

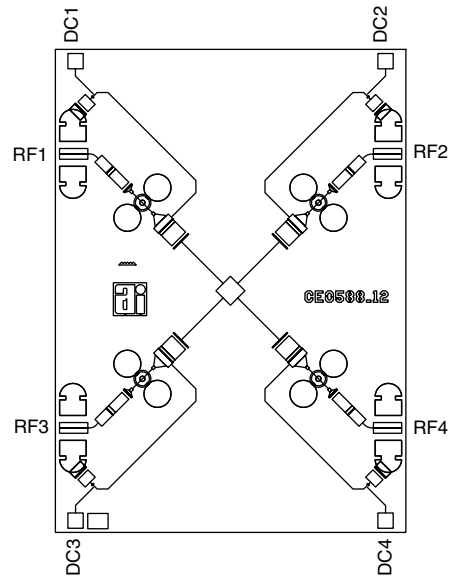

Chip size: 2.184 x 2.995 mm.