

53257	RADIATION TOLERANT 120VDC – 2A POWER MOSFET OPTOCOUPLER	<i>Mii</i>
--------------	--	------------

<p>Features:</p> <ul style="list-style-type: none"> • Design for 100 krad(Si) Total Dose • Hermetically Sealed in Surface Mount Package • Low On-resistance • 2A Continuous Output Current • Operation over Full Military Temperature Range -55°C to +125°C • Optically Coupled • Input / Output Isolation Tested to 1000 VDC • Shock and Vibration Resistance 	<p>Applications:</p> <ul style="list-style-type: none"> • Satellite/Space Systems • Military/High Reliability Systems • Power Distribution/Switching • Solenoid Driver • Stepper Motor Driver • Switching Heaters
---	--

DESCRIPTION

The 53257 is a radiation tolerant Power MOSFET Optocoupler designed for military and space applications. This light-weight device is resistant to damage from severe shock and vibration, and is immune to contact related problems inherent in electro-mechanical relays. The device is enclosed in a hermetic metal package to ensure reliability in harsh environments. Effective isolation of 1000 VDC between control and load circuits is achieved through the use of optical coupling.

Functionally, the device operates as a single-pole single-throw, normally open (1 Form A) DC solid-state relay. The 53257 SSR is actuated by an input current of 5 to 15 mA, which can be supplied from a standard TTL device. Output is provided by a power MOSFET exhibiting low $R_{DS(ON)}$ and capable of carrying a continuous current of 2 amperes. This device is designed to function with minimal degradation after exposure to 100 krad(Si) total dose. This device is available in a variety of quality of levels from COTS to class K including any custom screening requirements. The basic data sheet part is environmentally screened to H level in accordance with Table C-IX of MIL-PRF-38534.

ABSOLUTE MAXIMUM RATINGS

Output Voltage	150 VDC
Continuous Output current	2 A
Storage Temperature Range	-65°C to +150°C
Operating Junction Temperature	+150°C
Lead Solder Temperature, for 10 seconds	300°C
Continuous Input Current	20 mA
Peak Input Current ⁽¹⁾	100 mA
Reverse Input Voltage	6 VDC

WEIGHT:3.7 grams (typical)

RADIATION TOLERANT

This device contains radiation hardened components and/or other features that provide a level of radiation tolerance. Micropac does not guarantee any level of radiation hardness. Specific lot testing is required to determine the level of radiation hardness. Micropac does not offer this device as compliant to Appendix G (RHA Requirements) of MIL-PRF-38534.

Micropac Industries cannot assume any responsibility for any circuits shown or represent that they are free from patent infringement. Micropac reserves the right to make changes at any time in order to improve design and to supply the best product possible.

RECOMMENDED OPERATING CONDITIONS:

Parameter	Symbol	Min.	Max.	Units
Output Voltage ⁽⁵⁾	$V_{O(OFF)}$		120	VDC
Continuous Output Current	$I_{O(ON)}$		2	A
Input Current (on)	$I_{F(ON)}$	5	15	mA
Input Voltage (off)	$V_{F(OFF)}$	0	1	VDC
Operating Case Temperature	T_C	-55	125	°C

ELECTRICAL SPECIFICATIONS (Pre-Irradiation)

 $T_C = -55^{\circ}\text{C}$ to $+125^{\circ}\text{C}$ unless otherwise specified

Parameter	Symbol	Min.	Typ.*	Max.	Units	Test Conditions	Notes
Output On-Resistance	$R_{(ON)}$	—	.110	.220	Ω	$I_F = 15\text{ mA}$ $I_O = 2\text{ A}$ Pulse width = 10 ms Duty cycle $\leq 10\%$	
Output Leakage Current	$I_{O(OFF)}$	—	—	250	μA	$V_F = 1\text{ VDC}$ $V_O = 150\text{ VDC}$	
Input Forward Voltage	V_F	—	—	4.20	VDC	$I_F = 15\text{ mA}$	
Input Reverse Breakdown Voltage	V_R	6	40	—	VDC	$I_R = 10\ \mu\text{A}$	
Input-Output Leakage Current	I_{I-O}	—	—	1	μA	$R_H \leq 45\%$, $t = 5\text{ s}$ $V_{I-O} = 1000\text{ VDC}$ $T_C = 25^{\circ}\text{C}$	2, 3
Turn-On Time	t_{ON}	—	—	8	ms	$I_F = 15\text{ mA}$ $I_O = 2\text{ A}$ Pulse width = 10 ms Duty cycle $\leq 10\%$	Figure 3
Turn-Off time	t_{OFF}	—	—	2	ms		Figure 3
Rise Time	t_R	—	—	6	ms		4, Figure 3
Fall Time	t_F	—	—	1	ms		
Thermal Resistance (junction-case)	θ_{JC}	—	5.5	—	°C/W		

* All typical values are at $T_C = 25^{\circ}\text{C}$

Notes:

1. Non-repetitive, pulse width $\leq 100\ \mu\text{s}$, $T_C = 25^{\circ}\text{C}$.
2. Input pins shorted together and output pins shorted together.
3. Input-output potential applied momentarily, not a steady state operating condition.
4. Rise time is measured from 10% to 90% of load current (90% to 10% of V_O).
Fall time is measured from 90% to 10% of load current (10% to 90% of V_O).
5. The user should apply the appropriate transient suppression technique to the output terminals of the relay when the loads are inductive enough to generate voltage spikes.

Micropac Industries cannot assume any responsibility for any circuits shown or represent that they are free from patent infringement.
Micropac reserves the right to make changes at any time in order to improve design and to supply the best product possible.

INPUT	OUTPUT
ON	ON
OFF	OFF

Figure 1. Truth Table

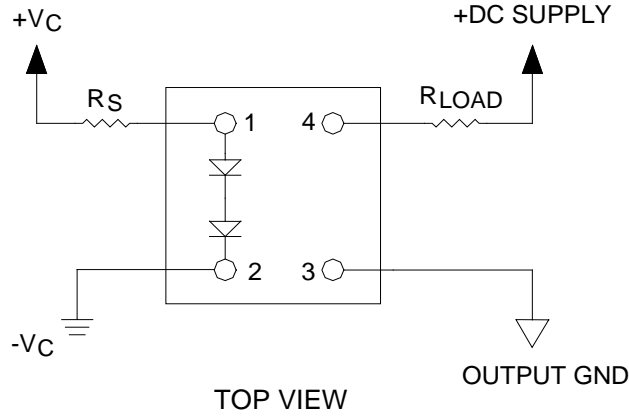

Figure 2. Terminal Connections

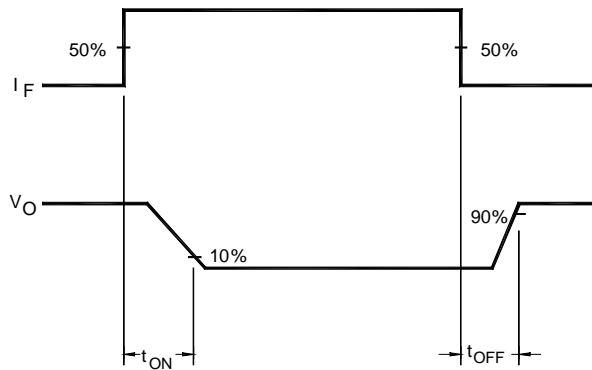
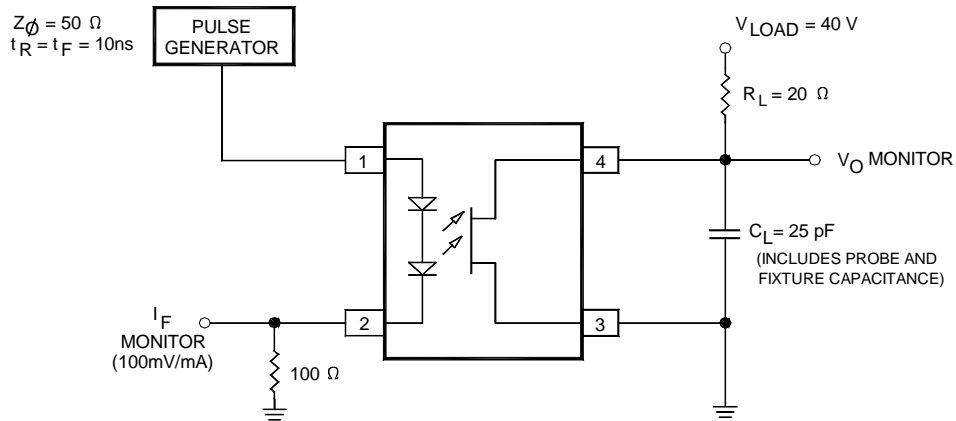
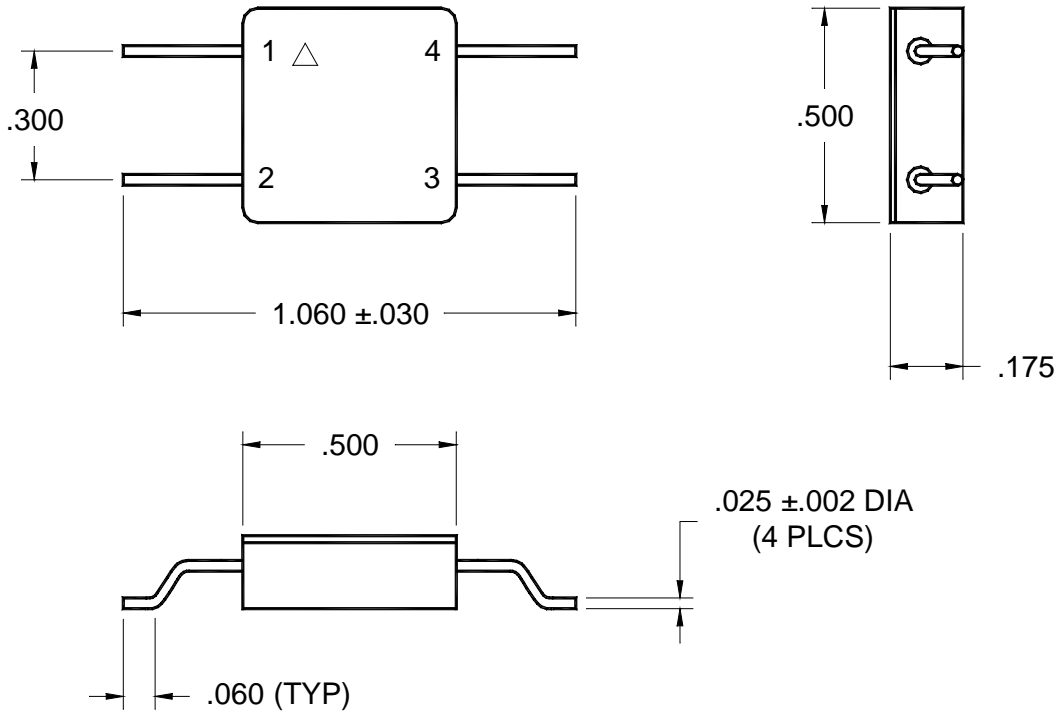

Figure 3. Switching Waveforms and Test Circuits

Micropac Industries cannot assume any responsibility for any circuits shown or represent that they are free from patent infringement. Micropac reserves the right to make changes at any time in order to improve design and to supply the best product possible.

CASE OUTLINE



ORDERING GUIDE

Mii Part Number	Description	Lead Finish	Screening Level
53257-101	Radiation Tolerant, 120 VDC, 2 A, Power MOSFET Optocoupler	Solder Leads	No Screening
53257-102	Radiation Tolerant, 120 VDC, 2 A, Power MOSFET Optocoupler	Gold Leads	No Screening
53257-111	Radiation Tolerant, 120 VDC, 2 A, Power MOSFET Optocoupler	Solder Leads	EE and Screening to H Level ^{1/}
53257-112	Radiation Tolerant, 120 VDC, 2 A, Power MOSFET Optocoupler	Gold Leads	EE and Screening to H Level ^{1/}
53257-113	Radiation Tolerant, 120 VDC, 2 A, Power MOSFET Optocoupler	Solder Leads	EE and Screening to K Level ^{1/}
53257-114	Radiation Tolerant, 120 VDC, 2 A, Power MOSFET Optocoupler	Gold Leads	EE and Screening to K Level ^{1/}
53257-119	Radiation Tolerant, 120 VDC, 2 A, Power MOSFET Optocoupler	Solder Leads	EE, QCI and Screening to K Level ^{2/}

Notes:

- 1) Element Evaluation and Screening (Table C-IX) to MIL-PRF-38534
- 2) Element Evaluation, QCI and Screening (Table C-IX) to MIL-PRF-38534

Micropac Industries cannot assume any responsibility for any circuits shown or represent that they are free from patent infringement. Micropac reserves the right to make changes at any time in order to improve design and to supply the best product possible.