

3.3V SM HCMOS VCXO WITH TRI-STATE

SPECIFICATIONS		VKB61B5
Frequency Range		1.0MHz to 45MHz
Frequency Vs Temperature		±25ppm
Frequency Tolerance		±50ppm (Note 1)
Temperature Range		-40°C to +85°C
Output	Waveform	TTL/HCMOS Squarewave
	Load	5TTL/15pF
	Voltage	Voh 2.97V Minimum Vol 0.33V Maximum
	Current	Ioh -1.0mA Iol 4.0mA
	Duty Cycle	45/55 Maximum @ 1.65V
	Rise/Fall Time	5nS Maximum
	Jitter	1.0ps RMS Maximum over 12kHz to 20MHz bandwidth 5.0ps RMS Maximum over 10Hz to 20MHz bandwidth
Tri-State Input	Output E/D Time	150nS Typical
	Enable (Vih)	2.7V Minimum
	Disable (Vil)	0.3V Maximum
		Oscillator output is enabled with no connection on pin 5
Frequency Control Input		Positive Transfer Characteristic
Pullability		±100ppm Minimum
Control Voltage (Vc)		0.15Vdc to 3.15Vdc
Center Frequency		1.65Vdc ±0.5Vdc
Monotonic Linearity		< ±10%
Input Impedance		50K ohms Nominal
Modulation Bandwidth		10KHz Minimum
Supply Voltage		+3.3Vdc ±0.3Vdc (Note 2)
Supply Current		1.0 to 30 MHz, 15 mA Maximum 30 to 45 MHz, 25 mA Maximum
Package		Hermetically sealed, leadless ceramic package

NOTE 1- Inclusive of calibration tolerance at 25°C, operating temperature range, supply voltage change, load change, and aging, with Vc= 1.65Vdc.

NOTE 2- A bypass capacitor of .01uF must be used between Vdd and Gnd.

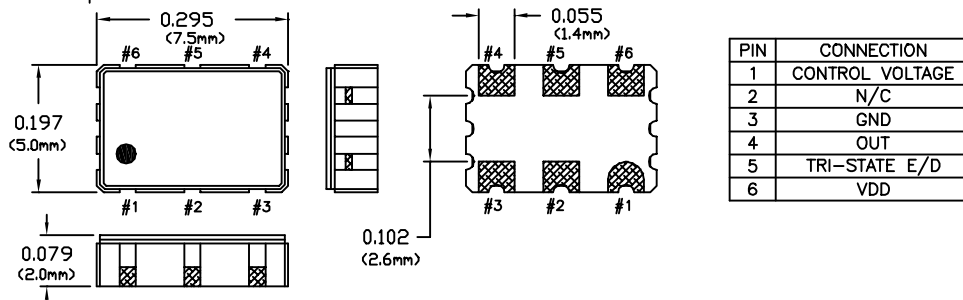

OUTPUT WAVEFORM

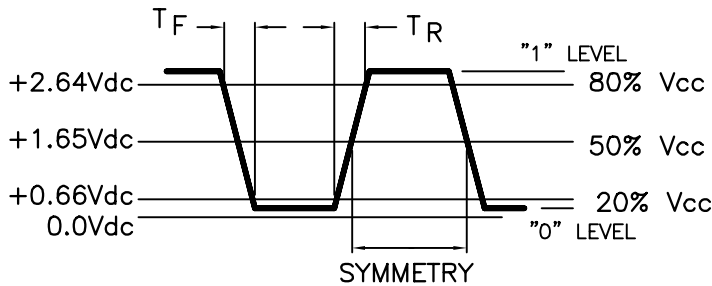

TEST CIRCUIT

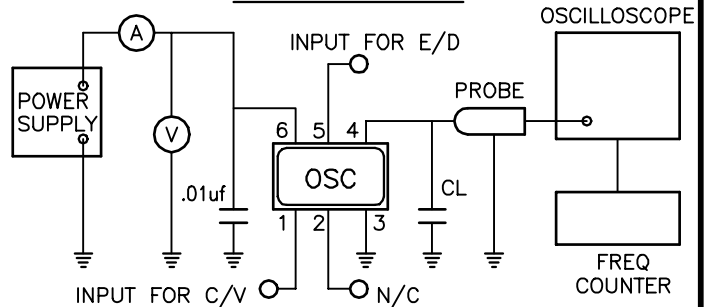

MECHANICAL CHARACTERISTICS

FREE DROP:

The specimen shall meet electrical characteristics after tested 3 times Free Drop testing on the hard wooden board from a height of 75cm.

VIBRATION:

The specimen shall meet electrical characteristics after tested by the following conditions; 10-55Hz 1.5mm Amplitude, 55-2000Hz 20G's, 2 hours for each phase.

THERMAL SHOCK:

After applied Thermal Shock of 245°C max x 10 sec max x 2 times, or 215°C max x 180 sec max, the specimen shall meet electrical characteristics.

SOLDERABILITY: (EIAJ-RCX-0102/101 Condition 1a)

1. Flux: MIL-F-14256 (WW Rosin=25%, Isopropyl alcohol=75%)
2. Solder: QQ-S-571 (Sn=63%, Pb=37%)
3. Solder bath temperature: 235°C ±5°C.
4. Depth of immersion: Up to electrical terminal.
5. Immersing time: Within 2 sec ±0.5 sec into solder bath.

After performing the above procedures, a newly soldered coverage shall be greater than 90%.

ENVIRONMENTAL CHARACTERISTICS

TEMPERATURE CYCLE:

The specimen shall meet electrical characteristics after tested 5 cycles of -55°C/30 min & +125°C/30 min.

HERMETICAL

No bubbles appear in Flourinert (FC-43) at 125°C ±5°C, for 5 minutes.

SOLVENT RESISTANCE:

Marking will withstand immersion in Isopropyl Alcohol or Trichloroethylene.

SOLDERING

GENERAL CONDITIONS:

245°C max x 10 sec max x 2 times max or 215°C max x 180 sec max x 1 time.

TYPICAL OPERATION DATA (Vapor phase reflow)

20 to 100 sec up to 215°C, 50 sec at 215°C then down to room temperature per 1 to 5°C/sec

TAPING AND REEL DIMENSIONS

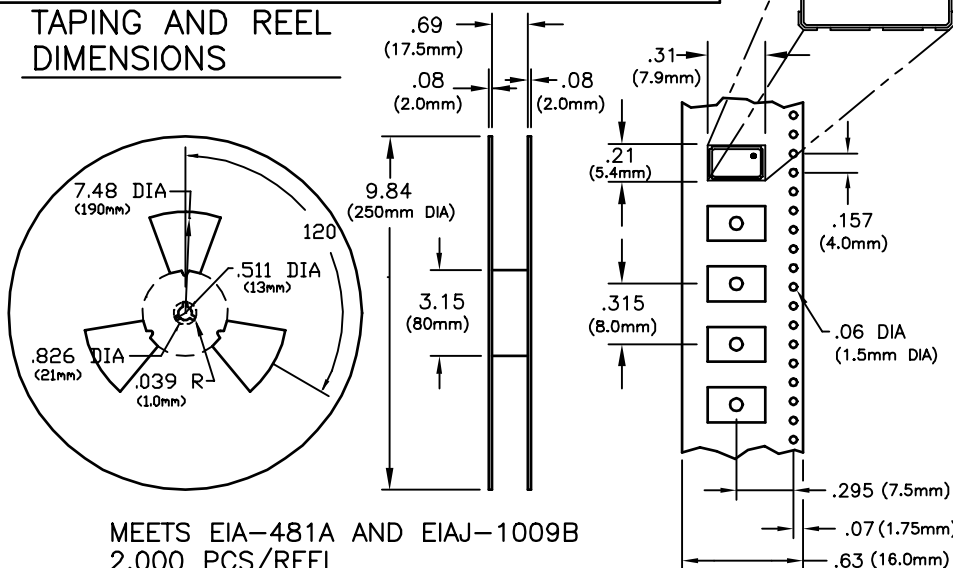

MEETS EIA-481A AND EIAJ-1009B
2,000 PCS/REEL

SUGGESTED PAD LAYOUT

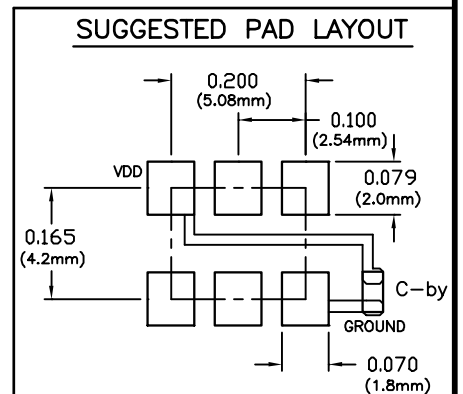

Bypass capacitor, C-by, should be ceramic capacitor ≥ .01uf.

BULLETIN #: VX273

REV: 06

Specifications subject to change without notice.

C-W © 1999

INT PAGE 2 OF 2

DATE: 9/17/01

ISSUED BY: _____

Dimensional ±.02" (±0.5mm)
Tolerance: ±.008" (±0.2mm)