

66125

**DUAL CHANNEL, HERMETICALLY SEALED 20 PIN LCC
VERY HIGH SPEED, SIMILAR TO 4N55**

Mii

**OPTOELECTRONIC PRODUCTS
DIVISION**

Features:

- DSCC Drawing 87679032X
- 1500 Vdc isolation test voltage
- TTL and CMOS compatible
- 2mHZ bandwidth typical
- High radiation immunity
- Hermetic Package

Applications:

- Military and Space
- High reliability systems
- Voltage Level Shifting
- Isolated Receiver Input
- Communication systems
- Medical systems

DESCRIPTION

The **66125** optocoupler contains two completely isolated optocouplers in a hermetically sealed 20 pin LCC package. Each channel provides high switching speeds while providing high isolation (1500Vmin) over the full military temperature range (-55° to +125°C). The 66125 is available in standard and screened versions or tested to customer specifications.MIL-PRF-38534.

ABSOLUTE MAXIMUM RATINGS

Storage Temperature.....	-65°C to +150°C
Operating Free-Air Temperature Range	-55°C to +125°C
Lead Solder Temperature.....	260°C for 10s (1.6mm below seating plane)
Peak Forward Input Current	40mA (1ms duration)
Average Forward Input Current	20mA
Input Power Dissipation	40mW
Reverse Input Voltage (each channel).....	5V
Supply Voltage - V _{CC} (each channel)	-0.5V to 20V
Output Current - I _O (each channel)	20mA
Output Power Dissipation (each channel)..(derate linearly at a rate of 1.4mW/°C above 100°C)	50mW
Output Voltage - V _O (each channel).....	-0.5V to 20V
Base Current (each channel).....	5mA

Package Dimensions

Schematic Diagram

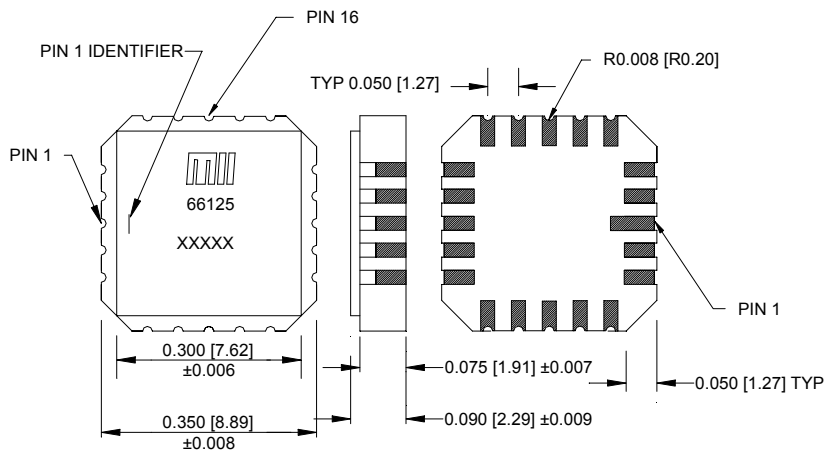

ALL DIMENSIONS ARE IN INCHES [MILLIMETERS]

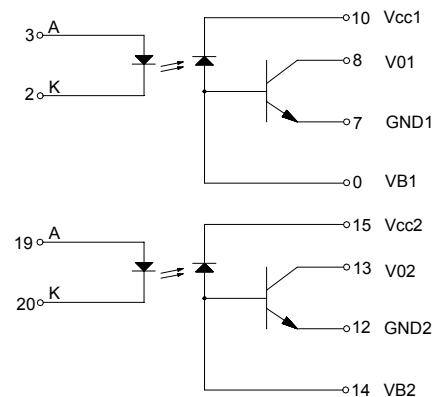

ELECTRICAL CHARACTERISTICST_a = -55°C to 125°C unless otherwise specified.

PARAMETER	SYMBOL	MIN	TYP	MAX	UNITS	TEST CONDITIONS	NOTE
Current Transfer Ratio	CTR	9	20		%	I _F = 16mA, V _O = 0.4V, V _{CC} = 4.5V	1, 2
Output Leakage Current	I _{OH1}		70	250	μA	I _F = 250μA, V _{CC} = V _O = 18V I _F (other channel) = 20mA	1
Logic High Output Current	I _{OH}		20	100	μA	I _F = 0, V _{CC} = V _O = 18V I _F (other channel) = 20mA	1
High Level Output Current	I _{CCH}		0.2	10	μA	I _F = 0, V _{CC} = 18V I _F (other channel) = 20mA	1
Low Level Supply Current	I _{CCL}		35	200	μA	I _{F1} = I _{F2} = 20mA, V _{CC} = 18V	1
Input Forward Voltage	V _F		1.5	1.8	V	I _F = 20mA	1
Input Reverse Breakdown Voltage	BV _R	3			V	I _R = 10μA	1
Input-Output Insulation Leakage Current	I _{I-O}			1.0	μA	V _{I-O} = 1500Vdc, Relative Humidity = 45% t _A = 25°C, t = 5s	3
Propagation Delay Time To High Output Level	t _{PLH}		2	6	μs	I _F = 16mA, V _{CC} = 5V, R _L = 8.2kΩ C _L = 50pF	1
Propagation Delay Time To Low Output Level	t _{PHL}		0.4	2	μs	I _F = 16mA, V _{CC} = 5V, R _L = 8.2kΩ C _L = 50pF	1

TYPICAL CHARACTERISTICST_a = 25°C, V_{CC} = 5V Each Channel

PARAMETER	SYMBOL	MIN	TYP	MAX	UNITS	TEST CONDITIONS	NOTE
Input Capacitance	C _{IN}		120		pF	V _F = 0, f = 1MHz	1
Capacitance (Input-Output)	C _{I-O}		1.0		pF	f = 1MHz, V _F = 0	1, 4
Capacitance (Input-Input)	C _{I-I}		0.55		pF	f = 1MHz	3
Input Diode Temperature Coefficient	$\frac{\Delta V_F}{\Delta T_A}$		-1.9		mV/°C	I _F = 18mA	1
Resistance (Input-Output)	R _{I-O}		10 ¹²		Ω	V _{I-O} = 500Vdc	3
Input-Input Insulation Leakage Current	I _{I-I}		1		pA	Relative Humidity = 45% V _{I-I} = 500Vdc, t = 5s	3
Common Mode Transient immunity at High Output Level	CM _H	500	1000		V/μs	V _{CM} = 50V P-P, R _L = 8.2kΩ, I _F = 0mA	1, 5
Common Mode Transient Immunity at Low Output Level	CM _L	500	1000		V/μs	V _{CM} = 50V P-P, R _L = 8.2kΩ, I _F = 16mA	1, 6

NOTES:

- Each channel.
- CURRENT TRANSFER RATIO is defined as the ratio of output collector current, I_O, to the forward LED input current, I_F, times 100%.
- Measured between each input pair shorted together.
- Measured between each input pair shorted together and the output pins for that channel shorted together.
- CM_H is the maximum tolerable common mode transient to assure that the output will remain in a high logic state (ie. V_O > @.0V).
- CM_L is the maximum tolerable common mode transient to assure that the output will remain in a low logic state (ie. V_O < 0.8V).

RECOMMENDED OPERATING CONDITIONS:

PARAMETER	SYMBOL	MIN	MAX	UNITS
Input Current, Low Level	I _{FL}	0	250	μA
Supply Voltage	V _{CC}	2	18	V