

3 V InGaP HBT Power Amplifier



AP131-317

Features

- Single Supply, 3.2 V Nominal Operating Voltage
- Output Power Greater Than 35 dBm
- High Power Added Efficiency of 55%
- Ultra Small, Thermally Enhanced Micro Leadframe Package
- Low Current Standby Mode: < 10 μ A
- Integral Analog Power Control With 70 dB of Dynamic Range
- GPRS Class 12 Capable
- Designed to Work With AP132-317 as a Dual-/Tri-Band Solution

Description

The AP131-317 is a high performance IC power amplifier designed for use as the final amplification stage in GSM and GPRS mobile phones, and other digital wireless applications in the 800–950 MHz band. It features 3-cell battery operation, integrated analog power control with over 70 dB of dynamic range, and exceptional power added efficiency over the full battery voltage range. The amplifier is manufactured on an advanced InGaP HBT process, known industry-wide for its excellent reliability and performance. The AP131-317 is designed to be stable over a wide temperature range of -40 to +85°C and over a 10:1 output VSWR load. Output matching is provided externally to maximize performance, reduce costs, and allow optimal matching for output power and efficiency over a broader frequency range. A dual- and/or tri-band solution can be obtained by combining the AP131-317 with Alpha's AP132-317. The AP131-317 is packaged in a thermally enhanced, ultra small micro leadframe package.

DC Specifications

Parameter	Condition	Min.	Typ.	Max.	Unit
Supply Voltage		2.7	3.2	4.2	V
Leakage Current	$P_{IN} < -30$ dBm, $V_{APC1,2} = 0.1$ V			10	μ A
Power Control Voltage		0.1		2.6	V
Power Control Current				5	mA

-317

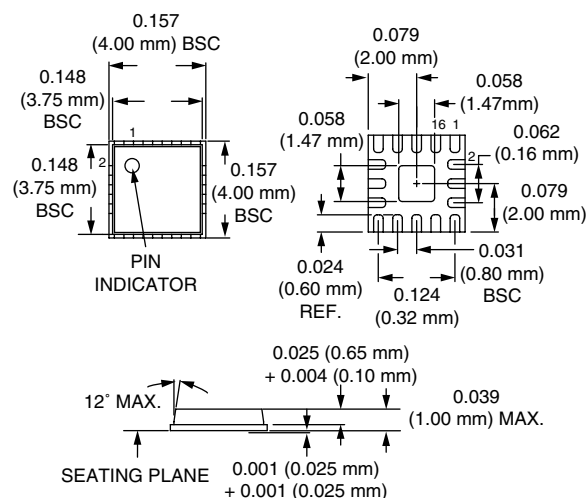

Absolute Maximum Ratings

Characteristic	Value
Supply Voltage V_{CC} , Standby Mode, $V_{APC} < 0.3$	6 V Max.
Power Control Voltage	4 V Max.
Input Power	15 dBm Max.
Operating Case Temperature	-40 to +85°C
Storage Temperature	-45 to +120°C

Electrical Specifications at 25°C

Parameter	Condition	Min.	Typ.	Max.	Unit
Frequency		880		915	MHz
Output Power	$V_{APC1,2} = 2.6\text{ V}, V_{CC} = 3.2\text{ V}, \text{CW}$ $V_{APC1,2} = 2.6\text{ V}, V_{CC} = 3.5\text{ V}, \text{CW}$ $V_{APC1,2} = 2.6\text{ V}, V_{CC} = 2.7\text{ V},$ $T = -40\text{ to }+85^\circ\text{C}$	34.0 35.0 33.8	35.2 36.0 34.5		dBm dBm dBm
Dynamic Range	$V_{APC} = 0.1\text{ to }2.6\text{ V}$	60			dB
Power Control Slope	$V_{APC} = 0.1\text{ to }2.6\text{ V}$		75	180	dB/ V_{APC}
Power Added Efficiency	$P_{OUT} = 34\text{ dBm}$	50	55		%
Input Power		3	6	10	dBm
Input VSWR	$P_{OUT} = 5\text{--}35\text{ dBm}$		1.5:1	2:1	
Forward Isolation	$P_{IN} = 6\text{ dBm}, V_{APC} = 0.1\text{ V}$ $P_{IN} = 8\text{ dBm}, V_{APC} = 0.1\text{ V}$			-50 -40	dBm dBm
Second Harmonic	At $P_{OUT}\text{ Max.}, V_{CC} = 3.2\text{ V}$		-55	-45	dBc
Third Harmonic	At $P_{OUT}\text{ Max.}, V_{CC} = 3.2\text{ V}$		-66	-50	dBc
All Others Non-harmonic Spurious				-40	dBm
Noise in the R_x Band	925 MHz, 100 KHz BW 935 MHz, 100 KHz BW 1805–1880 MHz, 100 KHz BW 1930–1990 MHz, 100 KHz BW			-72 -84 -76 -76	dBm dBm dBm dBm
Ruggedness	Output VSWR = 10:1 All Phase Angles, $V_{CC} = 4.2\text{ V}, P_{IN} = 10\text{ dBm}, V_{APC} = 2.6\text{ V}$	No Module Damage or Permanent Performance Degradation			
Stability	Output VSWR = 10:1 All Phase Angles, $V_{CC} = 4.2\text{ V}, P_{IN} = 10\text{ dBm}, V_{APC} = 2.6\text{ V}$			-36	dBm

Unless otherwise stated: pulsed operation @ 12.5% duty cycle, 50 Ω system, $V_{CC} = 3.2$ and $T_A = 25^\circ\text{C}$.

Pin Out

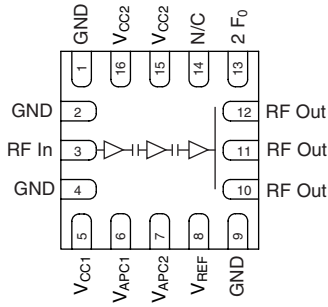

Pin Out Description

Pin	Symbol	Function
1	GND	Ground connection.
2	GND	Ground connection.
3	RF In	RF input to power amplifier. A 180 Ω resistor to ground with an 18 pF in series capacitor and a 100 pF DC blocking capacitor are required.
4	GND	Ground connection.
5	V _{CC}	Power supply input voltage. 1.8 nH bias injection inductor, and 100 pF, 1000 nF, 0.01 μF, 0.1 μF and 10 μF RF bypassing capacitors are required.
6	V _{APC1}	Power control input voltage for the first two stages of the amplifier. 100 pF and 10,000 pF RF bypassing capacitors are required. Can be connected to Pin 7 for single power control operation.
7	V _{APC2}	Power control input voltage for the third stage of the amplifier. 100 pF and 10,000 pF bypassing capacitors are required. Can be connected to Pin 6 for single power control operation.
8	V _{CC}	Power supply input voltage. 100 pF and 0.01 μF RF bypassing capacitors are required.
9	GND	Ground connection.
10	RF Out/V _{CC3}	RF output and power supply input voltage. 1. RF output: Two shunt matching capacitors, 16 pF high Q and a 4.7 pF, and a series 100 pF DC blocking capacitor is required. 2. V _{CC3} : 100 pF, 1000 nF, 0.01 μF, 0.1 μF and 10 μF RF bypassing capacitors are required.
11	RF Out/V _{CC3}	RF output and power supply input voltage. See description for Pin 10.
12	RF Out/V _{CC3}	RF output and power supply input voltage. See description for Pin 10.
13	2 F ₀	Second harmonic termination. This pin can be used to alter the second harmonic output characteristics, but for nominal GSM operation, no matching elements are required.
14	N/C	No connect.
15	V _{CC2}	Power supply input voltage. A 68 pF interstage tuning capacitor is required along with 100 pF, 1000 nF, 0.01 μF, 0.1 μF and 10 μF RF bypassing capacitors.
16	V _{CC2}	Power supply input voltage tied to Pin 15.