

225 WATT (20 AMP CONTINUOUS, 40 AMP PEAK)

PMD 16K, 17K



FEATURES

- Electrical specifications guaranteed for operating junction temperature range of 0 - 200°C
- Guaranteed and 100% tested for I_{SB} (Secondary Breakdown Current) insuring maximum performance at high energy levels
- Low thermal resistance for more useable power and lower operating temperatures
- Hermetically sealed

DESCRIPTION

The PMD 16K Series of devices are three-terminal NPN Darlington Power Transistors. The PMD 17K Series of devices are PNP Darlington Power Transistors. These devices are monolithic epitaxial base structures with built-in base to emitter shunt resistors. The devices are CVD glass passivated to increase reliability and provide reduced high-temperature reverse leakage current. This important feature enables this series of Darlington devices to meet guaranteed operating junction temperatures of 200°C. Internal diode protection (D1) of the Darlington configuration is built into the structure to limit the device power dissipation during negative overshoot.

ABSOLUTE MAXIMUM RATINGS

PARAMETER	SYMBOL	MAXIMUM	UNITS
Collector Emitter Voltage PMD16K, 17K80 PMD16K, 17K100	V_{CEO}	80 100	Vdc
Collector Base Voltage PMD16K, 17K80 PMD16K, 17K100	V_{CBO}	80 100	Vdc
Emitter Base Voltage	V_{EBO}	5	Vdc
Collector Current Continuous Peak	I_C	20 40	Adc
Base Current	I_B	0.5	Adc
Thermal Resistance	θ_{JC}	0.67	°C/Watt
Total Internal Power Dissipation ($\bar{\alpha}$ $T_C = 50^\circ\text{C}^1$)	P_D	225	Watts
Operating Junction and Storage Temperature	T_J T_{STG}	-65 to +200	°C

⁽¹⁾ For operation above $T_C = 50^\circ\text{C}$, derate @ 1.5 W/°C

DEVICE SELECTION GUIDE

DEVICE	VOLTAGE RATING	POLARITY
PMD16K80	80V	NPN
PMD16K100	100V	NPN
PMD17K80	80V	PNP
PMD17K100	100V	PNP

Excellent thermal resistance junction to case (θ_{JC}) provides for more useable power at lower operating temperatures. This, coupled with 100% I_{SB} testing, insures optimum performance and durability for DC motor control and other complementary Darlington applications. These Darlington devices are hermetically sealed copper/steel TO-3 packages providing high reliability and low thermal resistance.

PMD 16K, 17K

225 WATT (20 AMP CONTINUOUS, 40 AMP PEAK)

ELECTRICAL CHARACTERISTICS

All parameters are guaranteed at $T_J = 0$ to 200°C , unless otherwise specified.

Parameter	Symbol	Test Conditions	Minimum	Maximum	Units
ON CHARACTERISTICS					
Collector Emitter Saturation Voltage ¹	$V_{CE(sat)}$	$I_C = 10 \text{ Adc}; I_B = 40 \text{ mAdc}$		2.0	Vdc
Base Emitter Turn-on Voltage ¹	$V_{BE(on)}$	$I_C = 10 \text{ Adc}; V_{CE} = 3 \text{ Vdc}$		2.8	Vdc
Base Emitter Saturation ¹	$V_{BE(sat)}$	$I_C = 10 \text{ Adc}; I_B = 40 \text{ mAdc}$		2.8	Vdc
DC Current Gain ¹ PMD16K80, 100 PMD17K80, 100	h_{FE}	$I_C = 10 \text{ Adc}; V_{CE} = 3 \text{ Vdc}$ $T_J = 25^\circ\text{C}$	1000 800	20,000 20,000	
Forward Bias Secondary Breakdown Current	$I_{s/b}$	$V_{CE} = 30 \text{ Vdc}; T_A = 25^\circ\text{C}$ 1 sec non-repetitive pulse	7.5		Adc
OFF CHARACTERISTICS					
Collector Emitter Breakdown Voltage ¹ (Base Open) PMD16K, 17K80 PMD16K, 17K100	$V_{(BR)CEO}$	$I_{CE} = 100 \text{ mAdc}; T_J = 25^\circ\text{C}$	80 100		Vdc
Collector Emitter Sustaining Voltage ¹ PMD16K, 17K80 PMD16K, 17K100	$V_{(SUS)CER}$	$I_{CE} = 100 \text{ mAdc}; R_{BE} = 2.2\text{k}\Omega$	80 100		Vdc
Emitter Base Leakage Current	I_{EBO}	$V_{EB} = 5 \text{ Vdc}; I_C = 0\text{A}$		3.0	mAdc
Collector Emitter Leakage Current PMD16K, 17K80 PMD16K, 17K100	I_{CER}	$V_{CE} = 54 \text{ Vdc}; R_{BE} = 2.2\text{k}\Omega$ $V_{CE} = 67 \text{ Vdc}; R_{BE} = 2.2\text{k}\Omega$		7.0 7.0	mAdc
DYNAMIC CHARACTERISTICS					
Output Capacitance	C_{ob}	$V_{CB} = 10 \text{ Vdc}; I_E = 0 \text{ Adc}$ $f = 1 \text{ MHz}; T_J = 25^\circ\text{C}$		400	pF
Small Signal Current Gain	h_{fe}	$I_C = 7 \text{ Adc}; V_{CE} = 3 \text{ Vdc}$ $f = 1 \text{ kHz}; T_J = 25^\circ\text{C}$	300		
Common Emitter Short Circuit Forward Transfer Ratio	$ h_{fe} $	$I_C = 7 \text{ Adc}; V_{CE} = 3 \text{ Vdc}$ $f = 1 \text{ MHz}; T_J = 25^\circ\text{C}$	4		

(1) Pulse tested with pulse width $\leq 300 \mu\text{s}$ and duty cycle $\leq 2.0\%$

225 WATT (20 AMP CONTINUOUS, 40 AMP PEAK)

PMD 16K, 17K

OPERATIONAL DATA

POWER DERATING (PMD 16K, 17K SERIES)

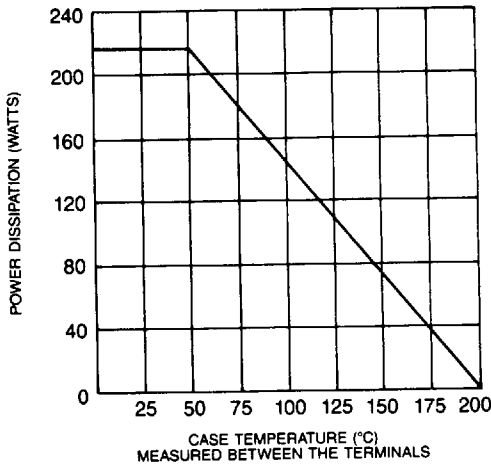

SAFE OPERATING AREA (PMD 16K, 17K SERIES)

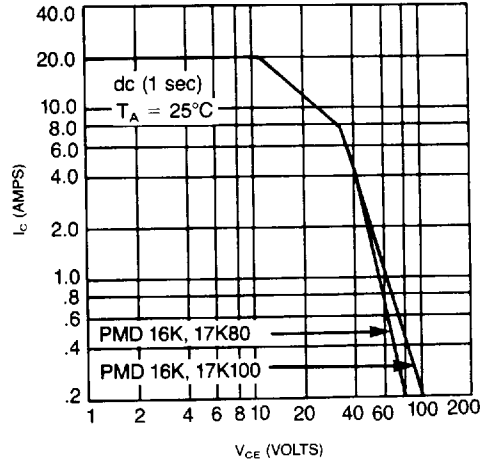

FORWARD VOLTAGE OF D1 (PMD 16K SERIES)

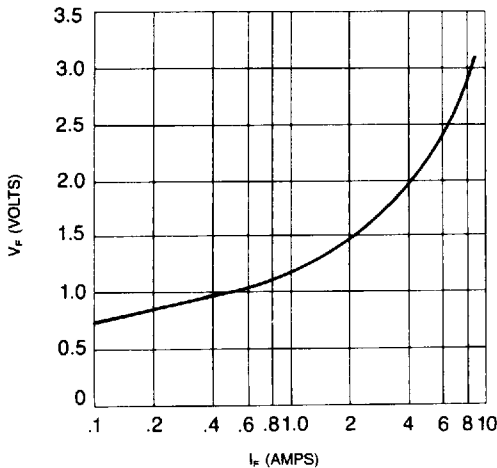

FORWARD VOLTAGE OF D1 (PMD 17K SERIES)

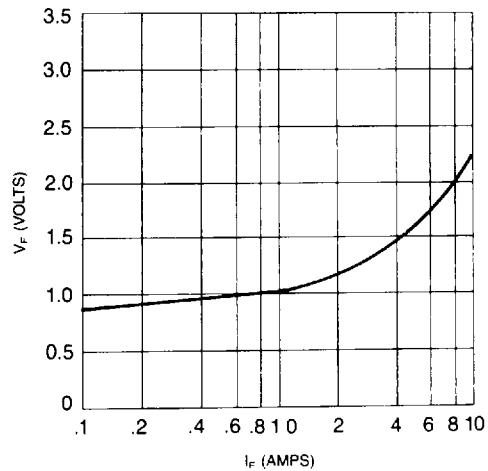

13

PMD 16K, 17K

225 WATT (20 AMP CONTINUOUS, 40 AMP PEAK)

OPERATIONAL DATA

ON VOLTAGE VS COLLECTOR CURRENT (PMD 16K SERIES)

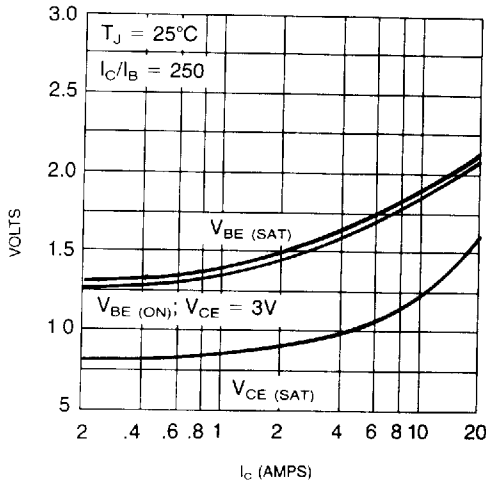

ON VOLTAGE VS COLLECTOR CURRENT (PMD 17K SERIES)

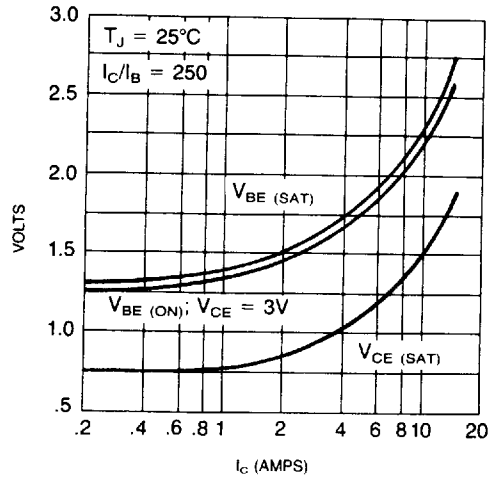

DC COLLECTOR CURRENT GAIN VS COLLECTOR CURRENT (PMD 16K SERIES)

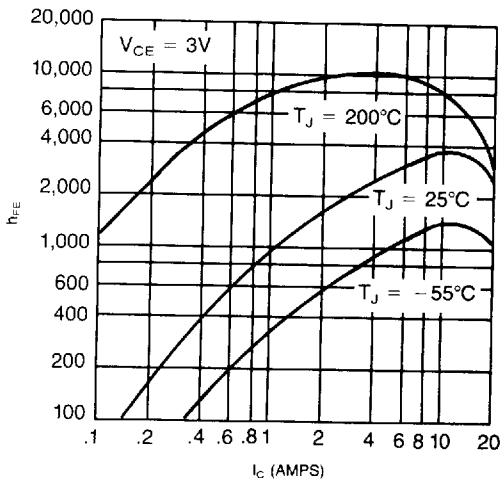

DC COLLECTOR CURRENT GAIN VS COLLECTOR CURRENT (PMD 17K SERIES)

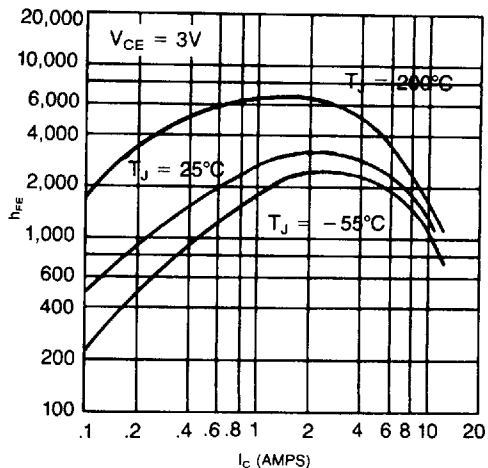

13

225 WATT (20 AMP CONTINUOUS, 40 AMP PEAK)

PMD 16K, 17K

OPERATIONAL DATA

COLLECTOR SATURATION REGION (PMD 16K SERIES)

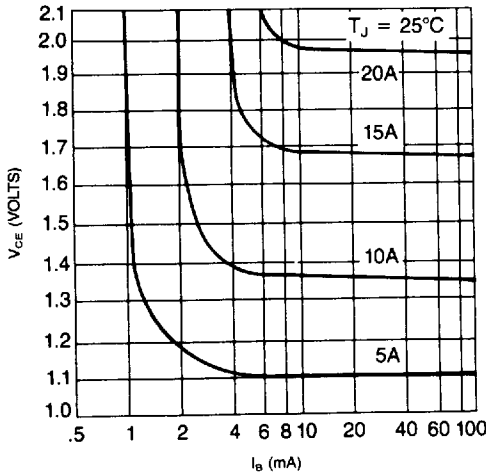

COLLECTOR SATURATION REGION (PMD 17K SERIES)

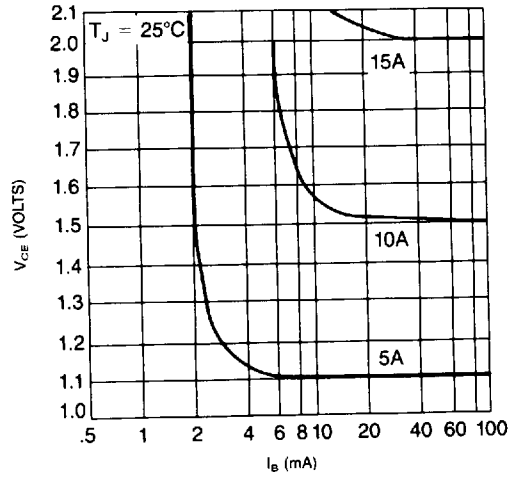

13

BLOCK DIAGRAMS

NPN

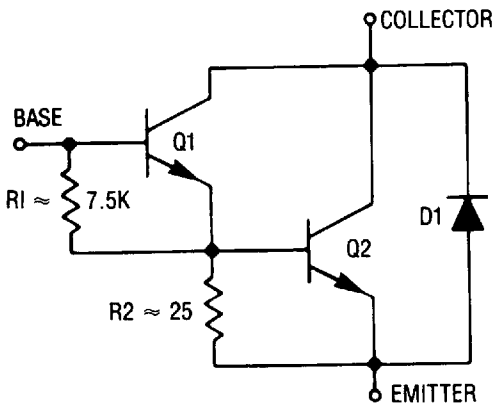

PNP

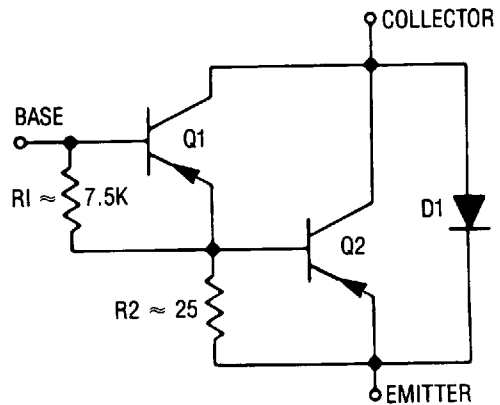

PMD 16K, 17K

225 WATT (20 AMP CONTINUOUS, 40 AMP PEAK)

DEVICE OUTLINE

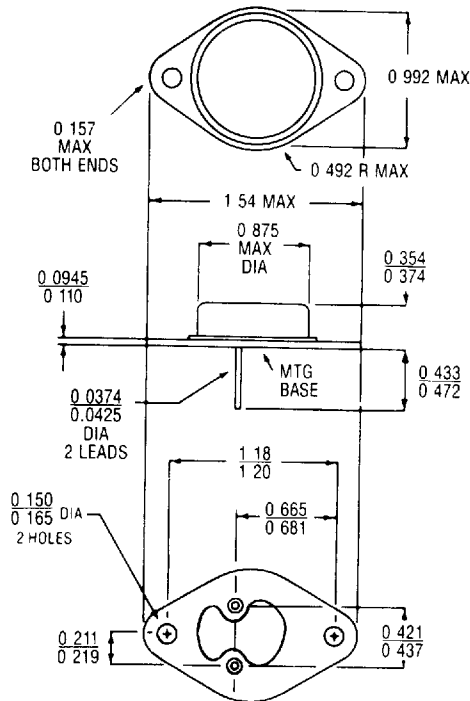

Bottom View

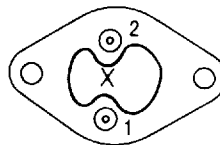

- 1 - Base
- 2 - Emitter
- Case Is Collector

NOTE: Case temperature measured at point X.
All dimensions are in inches.

13