

## 288M bits Direct Rambus™ DRAM

### EDR2518ABSE (512K words × 18 bits × 32s banks)

#### Description

The EDR2518AB (Direct RDRAM™) is a general purpose high-performance memory device suitable for use in a broad range of applications including computer memory, graphics, video, and any other application where high bandwidth and low latency are required.

The EDR2518AB is 1066MHz 288Mbits Direct Rambus DRAM (RDRAM®), organized as 16M words by 18 bits.

The use of Rambus Signaling Level (RSL) technology permits 800MHz to 1066MHz transfer rates while using conventional system and board design technologies.

Direct RDRAM devices are capable of sustained data transfers at 0.9375ns per two bytes (7.5ns per sixteen bytes).

The architecture of the Direct RDRAM devices allows the highest sustained bandwidth for multiple, simultaneous randomly addressed memory transactions.

The separate control and data buses with independent row and column control yield over 95% bus efficiency.

The Direct RDRAM devices 32 banks support up to four simultaneous transactions.

System oriented features for mobile, graphics and large memory systems include power management, byte masking.

It is offered in a CSP horizontal package suitable for desktop as well as low-profile add-in card and mobile applications. Direct RDRAM devices operate from a 2.5V supply.

#### Features

- Highest sustained bandwidth per DRAM device
  - 2.1 GB/s sustained data transfer rate
  - Separate control and data buses for maximized efficiency
  - Separate row and column control buses for easy scheduling and highest performance
  - 32 banks: four transactions can take place simultaneously at full bandwidth data rates
- Low latency features
  - Write buffer to reduce read latency
  - 3 precharge mechanisms for controller flexibility
  - Interleaved transactions
- Advanced power management:
  - Multiple low power states allows flexibility in power consumption versus time to active state
  - Power-down self-refresh
- Organization: 2K bytes pages and 32 banks, x 18
- Uses Rambus Signaling Level (RSL) for up to 1066MHz operation
- FBGA package is Sn-Pb or lead free solder (Sn-Ag-Cu)

**Ordering Information**

Part number	Organization* words × bits × Internal Banks	Clock frequency MHz (max.)	/RAS access time (ns)	Package
EDR2518ABSE-AEP	512K x 18 x 32s	1066	32 (-32P)	80-ball FBGA
EDR2518ABSE-AE		1066	32 (-32)	
EDR2518ABSE-AD		1066	35	
EDR2518ABSE-8C		800	40	
EDR2518ABSE-AEP-E		1066	32 (-32P)	
EDR2518ABSE-AE-E		1066	32 (-32)	
EDR2518ABSE-AD-E		1066	35	
EDR2518ABSE-8C-E		800	40	

Note: The "32s" designation indicates that this RDRAM core is composed of 32 banks which use a "split" bank architecture

**Part Number**

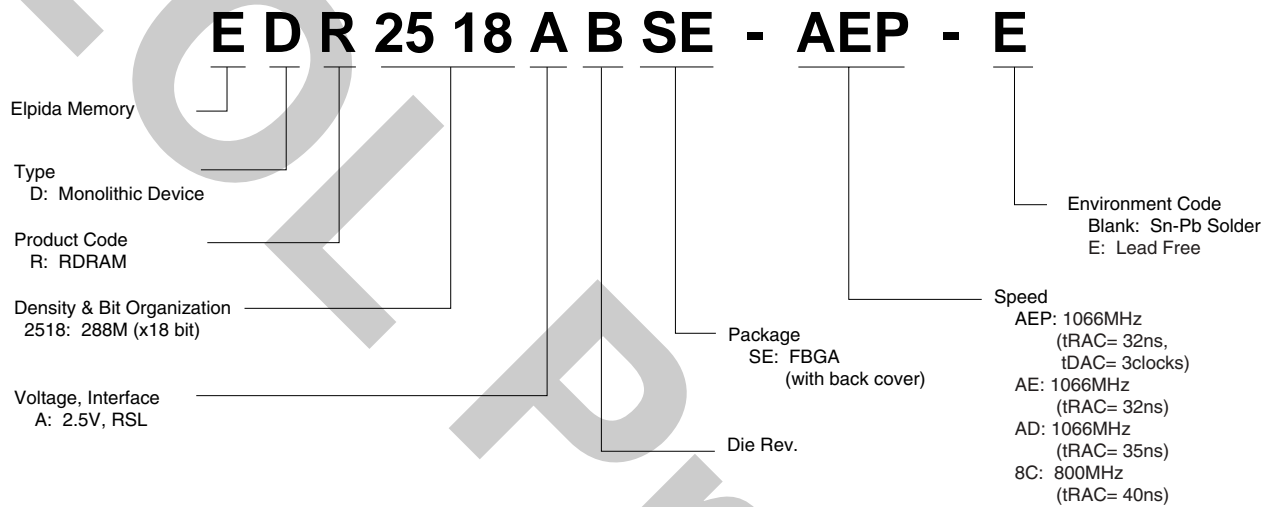

Pin Configuration

80-ball FBGA

Top View

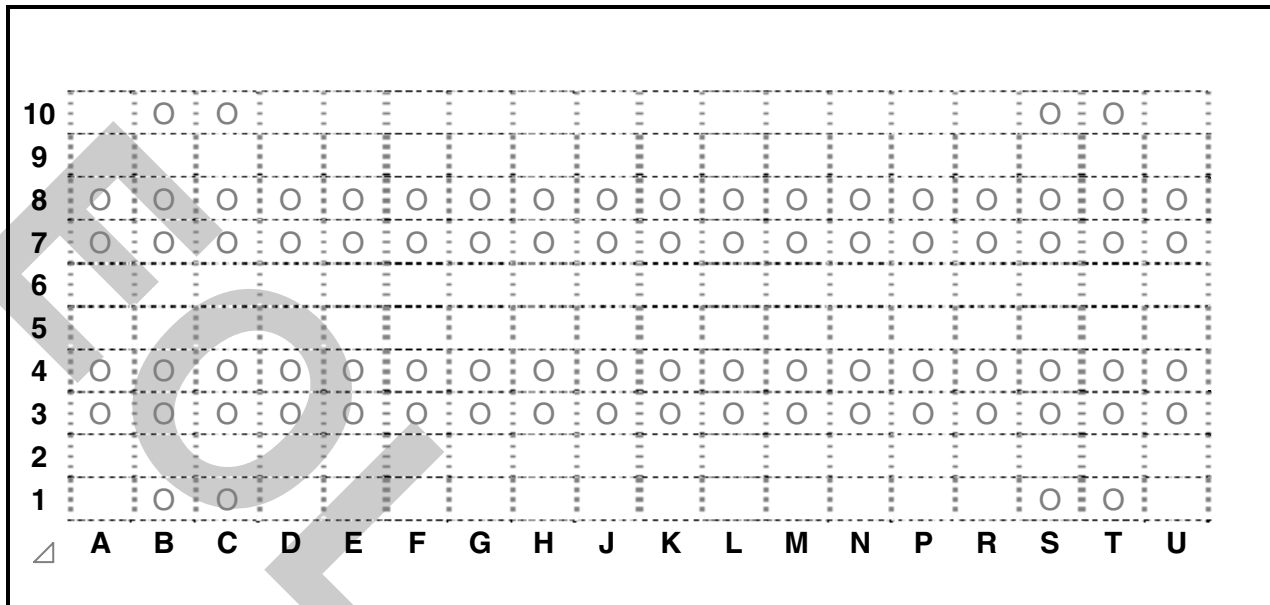

10		V <sub>DD</sub>	GND															GND	V <sub>DD</sub>		
9																					
8	GND	V <sub>DD</sub>	CMD	V <sub>DD</sub>	GND	GND <sub>a</sub>	GND <sub>a</sub>	V <sub>DD</sub>	V <sub>DD</sub>	GND	GND	V <sub>DD</sub>	V <sub>DD</sub>	GND	GND	VCMOS	V <sub>DD</sub>	GND			
7	V <sub>DD</sub>	DQA8	DQA7	DQA5	DQA3	DQA1	CTMN	CTM	ROW2	ROW0	COL3	COL1	DQB1	DQB3	DQB5	DQB7	DQB8	V <sub>DD</sub>			
6																					
5																					
4	GND	GND	DQA6	DQA4	DQA2	DQA0	CFM	CFMN	ROW1	COL4	COL2	COL0	DQB0	DQB2	DQB4	DQB6	GND	GND			
3	V <sub>DD</sub>	GND	SCK	VCMOS	GND	V <sub>DD</sub>	GND	V <sub>DDa</sub>	VREF	GND	V <sub>DD</sub>	GND	GND	V <sub>DD</sub>	SIO0	SIO1	GND	V <sub>DD</sub>			
2																					
1		V <sub>DD</sub>	GND															GND	V <sub>DD</sub>		
	A	B	C	D	E	F	G	H	J	K	L	M	N	P	R	S	T	U			

**Note** Some signals can be applied because this pin is not connected to the inside of the chip.

## Pin Description

Signal	Input / Output	Type	#pins	Description
SIO0, SIO1	Input / Output	CMOS <sup>Note1</sup>	2	Serial input/output. Pins for reading from and writing to the control registers using a serial access protocol. Also used for power management.
CMD	Input	CMOS <sup>Note1</sup>	1	Command input. Pins used in conjunction with SIO0 and SIO1 for reading from and writing to the control registers. Also used for power management.
SCK	Input	CMOS <sup>Note1</sup>	1	Serial clock input. Clock source used for reading from and writing to the control registers.
V <sub>DD</sub>			18	Supply voltage for the RDRAM core and interface logic.
V <sub>DDa</sub>			1	Supply voltage for the RDRAM analog circuitry.
V <sub>CMOS</sub>			2	Supply voltage for CMOS input/output pins.
GND			22	Ground reference for RDRAM core and interface.
GND <sub>a</sub>			2	Ground reference for RDRAM analog circuitry.
DQA8..DQA0	Input / Output	RSL <sup>Note2</sup>	9	Data byte A. Nine pins which carry a byte of read or write data between the Channel and the RDRAM.
CFM	Input	RSL <sup>Note2</sup>	1	Clock from master. Interface clock used for receiving RSL signals from the Channel. Positive polarity.
CFMN	Input	RSL <sup>Note2</sup>	1	Clock from master. Interface clock used for receiving RSL signals from the Channel. Negative polarity.
V <sub>REF</sub>			1	Logic threshold reference voltage for RSL signals.
CTMN	Input	RSL <sup>Note2</sup>	1	Clock to master. Interface clock used for transmitting RSL signals to the Channel. Negative polarity.
CTM	Input	RSL <sup>Note2</sup>	1	Clock to master. Interface clock used for transmitting RSL signals to the Channel. Positive polarity.
ROW2..ROW0	Input	RSL <sup>Note2</sup>	3	Row access control. Three pins containing control and address information for row accesses.
COL4..COL0	Input	RSL <sup>Note2</sup>	5	Column access control. Five pins containing control and address information for column accesses.
DQB8..DQB0	Input / Output	RSL <sup>Note2</sup>	9	Data byte B. Nine pins which carry a byte of read or write data between the Channel and the RDRAM.
Total pin count per package			80	

**Notes** 1.All CMOS signals are high-true ; a high voltage is a logic one and a low voltage is logic zero.

2.All RSL signals are low-true ; a low voltage is a logic one and a high voltage is logic zero.

Block Diagram

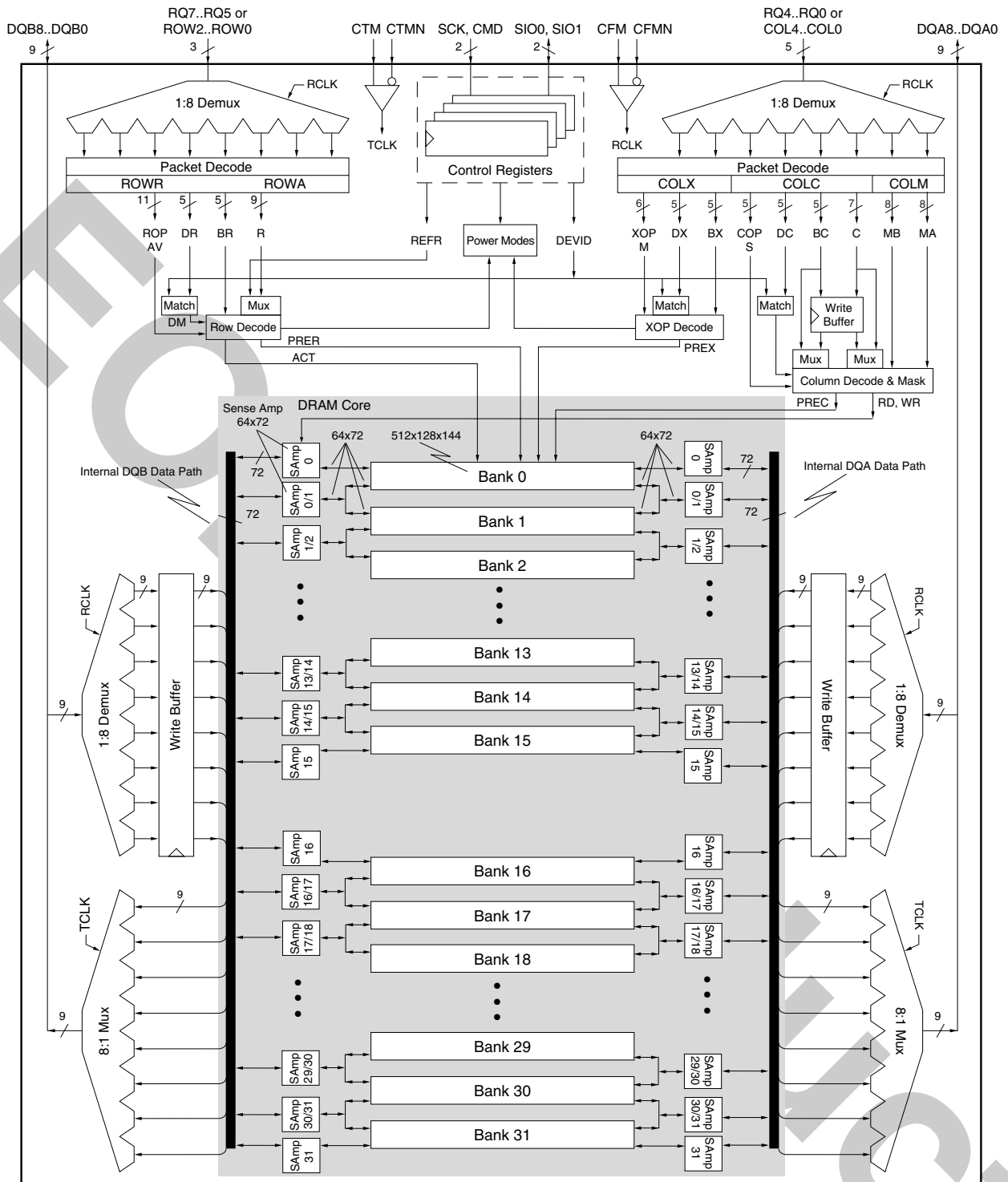

## CONTENTS

1. General Description .....	8
2. Packet Format.....	10
3. Field Encoding Summary .....	12
4. DQ Packet Timing.....	14
5. COLM Packet to D Packet Mapping .....	14
6. ROW-to-ROW Packet Interaction .....	16
7. ROW-to-COL Packet Interaction.....	18
8. COL-to-COL Packet Interaction.....	19
9. COL-to-ROW Packet Interaction.....	20
10. ROW-to-ROW Examples.....	21
11. Row and Column Cycle Description .....	22
12. Precharge Mechanisms .....	23
13. Read Transaction - Example .....	25
14. Write Transaction - Example .....	26
15. Write/Retire - Examples .....	27
16. Interleaved Write - Example.....	29
17. Interleaved Read - Example.....	30
18. Interleaved RRWW - Example.....	31
19. Control Register Transactions .....	32
20. Control Register Packets .....	33
21. Initialization.....	34
22. Control Register Summary .....	38
23. Power State Management .....	47
24. Refresh .....	52
25. Current and Temperature Control.....	54
26. Electrical Conditions.....	55
27. Timing Conditions .....	56
28. Electrical Characteristics.....	58
29. Timing Characteristics.....	58
30. RSL Clocking .....	59
31. RSL - Receive Timing.....	60
32. RSL - Transmit Timing .....	61
33. CMOS - Receive Timing .....	62
34. CMOS - Transmit Timing.....	64
35. RSL - Domain Crossing Window.....	65
36. Timing Parameters .....	66
37. Absolute Maximum Ratings.....	67

38. I<sub>DD</sub> - Supply Current Profile..... 67

39. Capacitance and Inductance..... 68

40. Interleaved Device Mode..... 70

41. Glossary of Terms..... 74

42. Package Drawing..... 76

43. Recommended Soldering Conditions..... 77

FOR Product

## 1. General Description

The figure on page 5 is a block diagram of the EDR2518ABSE. It consists of two major blocks : a “core” block built from banks and sense amps similar to those found in other types of DRAM, and a Direct Rambus interface block which permits an external controller to access this core at up to 2.1 GB/s.

**Control Registers:** The CMD, SCK, SIO0, and SIO1 pins appear in the upper center of the block diagram. They are used to write and read a block of control registers. These registers supply the RDRAM device configuration information to a controller and they select the operating modes of the device. The nine bit REFR value is used for tracking the last refreshed row. Most importantly, the five bits DEVID specifies the device address of the RDRAM device on the Channel.

**Clocking:** The CTM and CTMN pins (Clock-To-Master) generate TCLK (Transmit Clock), the internal clock used to transmit read data. The CFM and CFMN pins (Clock-From-Master) generate RCLK (Receive Clock), the internal clock signal used to receive write data and to receive the ROW and COL pins.

**DQA, DQB Pins:** These 18 pins carry read (Q) and write (D) data across the Channel. They are multiplexed / de-multiplexed from / to two 72-bit data paths (running at one-eighth the data frequency) inside the RDRAM device.

**Banks:** The 32 Mbyte core of the RDRAM device is divided into 32 one-Mbyte banks, each organized as 512 rows, with each row containing 128 dualocts (2K bytes), and each dualoct containing 16 bytes. A dualoct is the smallest unit of data that can be addressed.

**Sense Amps:** The RDRAM device contains 34 sense amps. Each sense amp consists of 1,024 bytes of fast storage (512 for DQA and 512 for DQB) and can hold one-half of one row of one bank of the RDRAM device. The sense amp may hold any of the 512 half-rows of an associated bank. However, each sense amp is shared between two adjacent banks of the RDRAM device. This introduces the restriction that adjacent banks may not be simultaneously accessed.

**RQ Pins:** These pins carry control and address information. They are broken into two groups. RQ7..RQ5 are also called ROW2..ROW0, and are used primarily for controlling row accesses. RQ4..RQ0 are also called COL4..COL0, and are used primarily for controlling column accesses.

**ROW Pins:** The principle use of these three pins is to manage the transfer of data between the banks and the sense amps of the RDRAM device. These pins are de-multiplexed into a 24-bit ROWA (row-activate) or ROWR (row-operation) packet.

**COL Pins:** The principle use of these five pins is to manage the transfer of data between the DQA/DQB pins and the sense amps of the RDRAM device. These pins are de-multiplexed into a 23-bit COLC (column-operation) packet and either a 17-bit COLM (mask) packet or a 17-bit COLX (extended-operation) packet.

**ACT Command:** An ACT (activate) command from an ROWA packet causes one of the 512 rows of the selected bank to be loaded to its associated sense amps (two 512 byte sense amps for DQA and two for DQB).

**PRER Command:** A PRER (precharge) command from an ROWR packet causes the selected bank to release its two associated sense amps, permitting a different row in that bank to be activated, or permitting adjacent banks to be activated.



**RD Command:** The RD (read) command causes one of the 128 dualocts of one of the sense amps to be transmitted on the DQA/DQB pins of the Channel.

**WR Command:** The WR (write) command causes a dualoct received from the DQA/DQB data pins of the Channel to be loaded into the write buffer. There is also space in the write buffer for the BC bank address and C column address information. The data in the write buffer is automatically retired (written with optional bytemask) to one of the 128 dualocts of one of the sense amps during a subsequent COP command. A retire can take place during a RD, WR, or NOCOP to another device, or during a WR or NOCOP to the same device. The write buffer will not retire during a RD to the same device. The write buffer reduces the delay needed for the internal DQA/DQB data path turn-around.

**PREC Precharge:** The PREC, RDA and WRA commands are similar to NOCOP, RD and WR, except that a precharge operation is performed at the end of the column operation. These commands provide a second mechanism for performing precharge.

**PREX Precharge:** After a RD command, or after a WR command with no byte masking (M=0), a COLX packet may be used to specify an extended operation (XOP). The most important XOP command is PREX. This command provides a third mechanism for performing precharge.

## 2. Packet Format

Figure 2-1 shows the formats of the ROWA and ROWR packets on the ROW pins. Table 2-1 describes the fields which comprise these packets. DR4T and DR4F bits are encoded to contain both the DR4 device address bit and a framing bit which allows the ROWA or ROWR packet to be recognized by the RDRAM device.

The AV (ROWA/ROWR packet selection) bit distinguishes between the two packet types. Both the ROWA and ROWR packet provide a five bit device address and a four bit bank address. An ROWA packet uses the remaining bits to specify a nine bit row address, and the ROWR packet uses the remaining bits for an eleven bit opcode field. Note the use of the “RsvX” notation to reserve bits for future address field extension.

Figure 2-1 also shows the formats of the COLC, COLM, and COLX packets on the COL pins. Table 2-2 describes the fields which comprise these packets.

The COLC packet uses the S (Start) bit for framing. A COLM or COLX packet is aligned with this COLC packet, and is also framed by the S bit.

The 23 bit COLC packet has a five bit device address, a four bit bank address, a six bit column address, and a four bit opcode. The COLC packet specifies a read or write command, as well as some power management commands.

The remaining 17 bits are interpreted as a COLM (M=1) or COLX (M=0) packet. A COLM packet is used for a COLC write command which needs bytemask control. The COLM packet is associated with the COLC packet from a time  $t_{TRR}$  earlier. An COLX packet may be used to specify an independent precharge command. It contains a five bit device address, a four bit bank address, and a five bit opcode. The COLX packet may also be used to specify some housekeeping and power management commands. The COLX packet is framed within a COLC packet but is not otherwise associated with any other packet.

**Table 2-1 Field Description for ROWA Packet and ROWR Packet**

Field	Description
DR4T, DR4F	Bits for framing (recognizing) a ROWA or ROWR packet. Also encodes highest device address bit.
DR3..DR0	Device address for ROWA or ROWR packet.
BR4..BR0	Bank address for ROWA or ROWR packet. RsvB denotes bits ignored by the RDRAM device.
AV	Selects between ROWA packet (AV=1) and ROWR packet (AV=0).
R8..R0	Row address for ROWA packet. RsvR denotes bits reserved for future row address extension.
ROP10..ROP0	Opcode field for ROWR packet. Specifies precharge, refresh, and power management functions.

**Table 2-2 Field Description for COLC Packet, COLM Packet, and COLX Packet**

Field	Description
S	Bit for framing (recognizing) a COLC packet, and indirectly for framing COLM and COLX packets.
DC4..DC0	Device address for COLC packet.
BC4..BC0	Bank address for COLC packet. RsvB denotes bits reserved for future extension (controller drivers 0's).
C6..C0	Column address for COLC packet.
COP3..COP0	Opcode field for COLC packet. Specifies read, write, precharge, and power management functions.
M	Selects between COLM packet (M=1) and COLX packet (M=0).
MA7..MA0	Bytemask write control bits. 1=write, 0=no-write. MA0 controls the earliest byte on DQA8..0.
MB7..MB0	Bytemask write control bits. 1=write, 0=no-write. MB0 controls the earliest byte on DQB8..0.
DX4..DX0	Device address for COLX packet.
BX4..BX0	Bank address for COLX packet. RsvB denotes bits reserved for future extension (controller drivers 0's).
XOP4..XOP0	Opcode field for COLX packet. Specifies precharge, I <sub>OL</sub> control, and power management functions.

Figure 2-1 Packet Formats

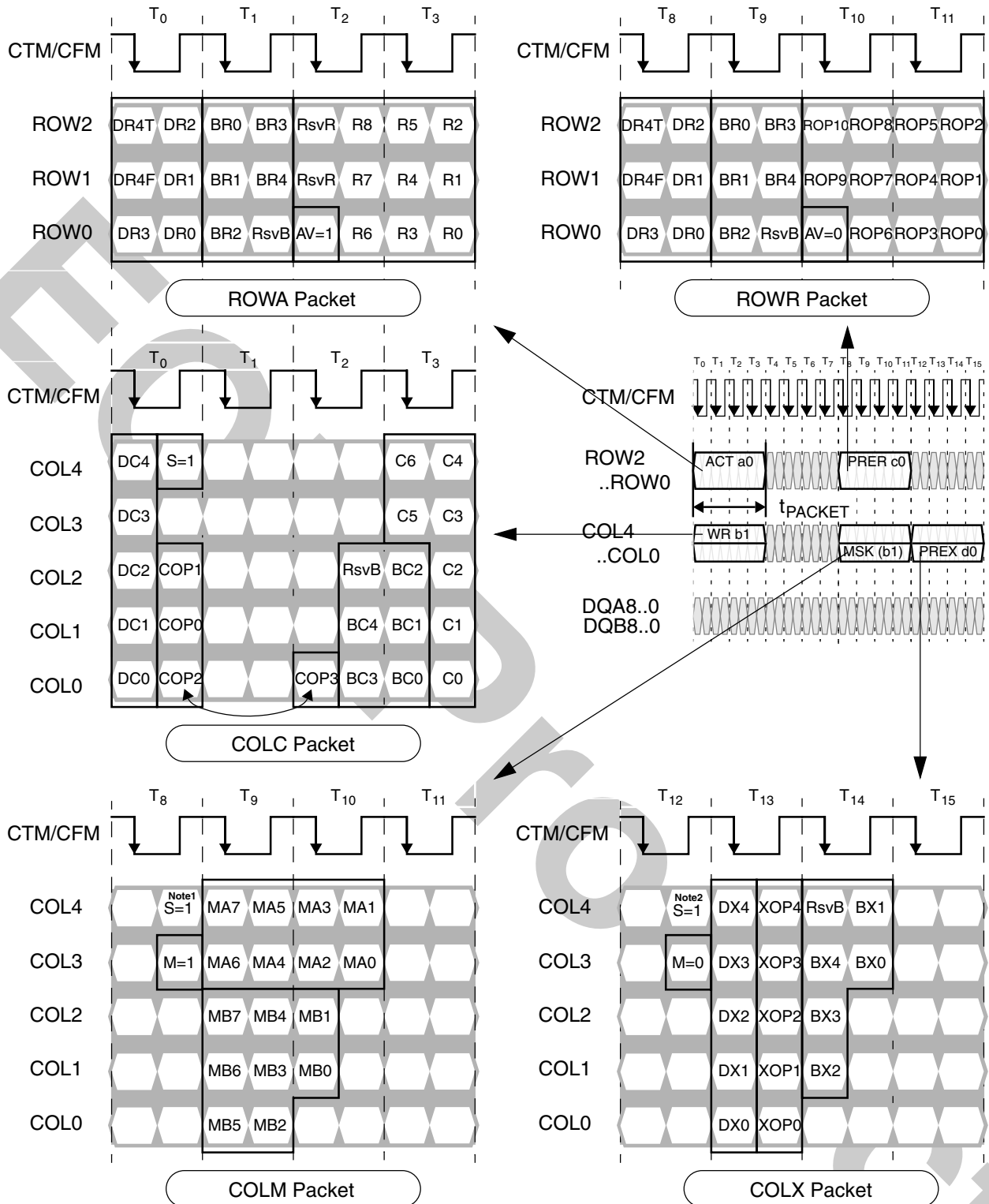

**Notes 1.** The COLM is associated with a previous COLC, and is aligned with the present COLC, indicated by the Start bit (S=1) position.

**2.** The COLX is aligned with the present COLC, indicates by the Start bit (S=1) position.

### 3. Field Encoding Summary

Table 3-1 shows how the six device address bits are decoded for the ROWA and ROWR packets. The DR4T and DR4F encoding merges a fifth device bit with a framing bit. When neither bit is asserted, the device is not selected. Note that a broadcast operation is indicated when both bits are set. Broadcast operation would typically be used for refresh and power management commands. If the device is selected, the DM (DeviceMatch) signal is asserted and an ACT or ROP command is performed.

**Table 3-1 Device Field Encodings for ROWA Packet and ROWR Packet**

DR4T	DR4F	Device Selection	Device Match signal (DM)
1	1	All devices (broadcast)	DM is set to 1
0	1	One device selected	DM is set to 1 if {DEVID4..DEVID0} == {0, DR3..DR0} else DM is set to 0
1	0	One device selected	DM is set to 1 if {DEVID4..DEVID0} == {1, DR3..DR0} else DM is set to 0
0	0	No packet present	DM is set to 0

Table 3-2 shows the encodings of the remaining fields of the ROWA and ROWR packets. An ROWA packet is specified by asserting the AV bit. This causes the specified row of the specified bank of this device to be loaded into the associated sense amps.

An ROWR packet is specified when AV is not asserted. An 11 bit opcode field encodes a command for one of the banks of this device. The PRER command causes a bank and its two associated sense amps to precharge, so another row or an adjacent bank may be activated.

The REFA (refresh-activate) command is similar to the ACT command, except the row address comes from an internal register REFR, and REFR is incremented at the largest bank address. The REFP (refresh-precharge) command is identical to a PRER command.

The NAPR, NAPRC, PDNR, ATTN, and RLXR commands are used for managing the power dissipation of the RDRAM and are described in more detail in “**23. Power State Management**”. The TCEN and TCAL commands are used to adjust the output driver slew rate and they are described in more detail in “**25. Current and Temperature Control**”.

**Table 3-2 ROWA Packet and ROWR Packet Field Encodings**

DM <small>Note1</small>	AV	ROP10..ROP0 Field										Name	Command Description	
		10	9	8	7	6	5	4	3	2 : 0				
0	—	—	—	—	—	—	—	—	—	—	—	—	—	No operation.
1	1	Row address										ACT	Activate row R8..R0 of bank BR4..BR0 of device and move device to ATTN <sup>Note2</sup> .	
1	0	1	1	0	0	0	x <sup>Note3</sup>	x	x	000	PRER	Precharge bank BR4..BR0 of this device.		
1	0	0	0	0	1	1	0	0	x	000	REFA	Refresh (activate) row REFR8..REFR0 of bank BR3..BR0 of device. Increment REFR if BR4..BR0=11111 (see Figure 24-1).		
1	0	1	0	1	0	1	0	0	x	000	REFP	Precharge bank BR4..BR0 of this device after REFA (see Figure 24-1).		
1	0	x	x	0	0	0	0	1	x	000	PDNR	Move this device into the powerdown (PDN) power state (see figure 23-3).		
1	0	x	x	0	0	0	1	0	x	000	NAPR	Move this device into the nap (NAP) power state (see Figure 23-3).		
1	0	x	x	0	0	0	1	1	x	000	NAPRC	Move this device into the nap (NAP) power state conditionally.		
1	0	x	x	x	x	x	x	x	0	000	ATTN <sup>Note2</sup>	Move this device into the attention (ATTN) power state (see Figure 23-1).		
1	0	x	x	x	x	x	x	x	1	000	RLXR	Move this device into the standby (STBY) power state (see Figure 23-2).		
1	0	0	0	0	0	0	0	0	x	001	TCAL	Temperature calibrate this device (see figure 25-2).		
1	0	0	0	0	0	0	0	0	x	010	TCEN	Temperature calibrate/enable this device (see Figure 25-2).		
1	0	0	0	0	0	0	0	0	0	000	NOROP	No operation.		

**Notes 1.** The DM (Device Match signal) value is determined by the DR4T, DR4F, DR3..DR0 field of the ROWA and ROWR packets.

See Table 3-1.

**2.** The ATTN command does not cause a RLX-to-ATTN transition for a broadcast operation (DR4T/DR4F=1/1).

**3.** An “x” entry indicates which commands may be combined. For instance, the three commands PRER/NAPRC/RLXR may be specified in one ROP value (011000111000).

Table 3-3 shows the COP field encoding. The device must be in the ATTN power state in order to receive COLC packets. The COLC packet is used primarily to specify RD (read) and WR (write) commands. Retire operations (moving data from the write buffer to a sense amp) happen automatically. See Figure 15-1 for a more detailed description.

The COLC packet can also specify a PREC command, which precharges a bank and its associated sense amps. The RDA/WRA commands are equivalent to a combining RD/WR with a PREC. RLXC (relax) performs a power mode transition. See **23. Power State Management**.

**Table 3-3 COLC Packet Field Encodings**

S	DC4..DC0 (select device) <sup>Note1</sup>	COP3..0	Name	Command Description
0	----	-----	—	No operation.
1	/= (DEVID4..0)	-----	—	Retire write buffer of this device.
1	== (DEVID4..0)	x000 <sup>Note2</sup>	NOCOP	Retire write buffer of this device.
1	== (DEVID4..0)	x001	WR	Retire write buffer of this device, then write column C6..C0 of bank BC4..BC0 to write buffer.
1	== (DEVID4..0)	x010	RSRV	Reserved, no operation.
1	== (DEVID4..0)	x011	RD	Read column C6..C0 of bank BC4..BC0 of this device.
1	== (DEVID4..0)	x100	PREC	Retire write buffer of this device, then precharge bank BC4..BC0 (see Figure 12-2).
1	== (DEVID4..0)	x101	WRA	Same as WR, but precharge bank BC4..BC0 after write buffer (with new data) is retired.
1	== (DEVID4..0)	x110	RSRV	Reserved, no operation.
1	== (DEVID4..0)	x111	RDA	Same as RD, but precharge bank BC4..BC0 afterward.
1	== (DEVID4..0)	1xxx	RLXC	Move this device into the standby (STBY) power state (see Figure 23-2).

**Notes 1.** “/=” means not equal, “==” means equal.

- 2.** An “x” entry indicates which commands may be combined. For instance, the two commands WR/RLXC may be specified in one COP value(1001).

Table 3-4 shows the COLM and COLX field encodings. The M bit is asserted to specify a COLM packet with two 8 bit bytemask fields MA and MB. If the M bit is not asserted, an COLX is specified. It has device and bank address fields, and an opcode field. The primary use of the COLX packet is to permit an independent PREX (precharge) command to be specified without consuming control bandwidth on the ROW pins. It is also used for the CAL (calibrate) and SAM (sample) current control commands (see **25. Current and Temperature Control**), and for the RLXX power mode command (see **23. Power State Management**).

**Table 3-4 COLM Packet and COLX Packet Field Encodings**

M	DX4..DX0 (select device)	XOP4..0	Name	Command Description
1	----	-	MSK	MB/MA bytemasks used by WR/WRA.
0	/= (DEVID4..0)	-	—	No operation.
0	== (DEVID4..0)	00000	NOXOP	No operation.
0	== (DEVID4..0)	1xxx0 <sup>Note</sup>	PREX	Precharge bank BX4..BX0 of this device (see Figure 12-2).
0	== (DEVID4..0)	x10x0	CAL	Calibrate (drive) I <sub>OL</sub> current for this device (see Figure 25-1).
0	== (DEVID4..0)	x11x0	CAL / SAM	Calibrate (drive) and Sample (update) I <sub>OL</sub> current for this device (see Figure 25-1).
0	== (DEVID4..0)	xxx10	RLXX	Move this device into the standby (STBY) power state (see Figure 23-2).
0	== (DEVID4..0)	xxxx1	RSRV	Reserved, no operation.

**Note** An “x” entry indicates which commands may be combined. For instance, the two commands PREX/RLXX may be specified in one XOP value (10010).

### 4. DQ Packet Timing

Figure 4-1 shows the timing relationship of COLC packets with D and Q data packets. This document uses a specific convention for measuring time intervals between packets: all packets on the ROW and COL pins (ROWA, ROWR, COLC, COLM, COLX) use the trailing edge of the packet as a reference point, and all packets on the DQA/DQB pins (D and Q) use the leading edge of the packet as a reference point.

An RD or RDA command will transmit a dualoct of read data Q a time  $t_{CAC}$  later. This time includes one to five cycles of round-trip propagation delay on the Channel. The  $t_{CAC}$  parameter may be programmed to a one of a range of values (8, 9, 10, 11, or 12  $t_{CYCLE}$ ). The value chosen depends upon the number of RDRAM devices on the Channel and the RDRAM device timing bin. See Figure 22-1(5/7) "TPARM Register" for more information.

A WR or WRA command will receive a dualoct of write data D a time  $t_{CWD}$  later. This time does not need to include the round-trip propagation time of the Channel since the COLC and D packets are traveling in the same direction.

When a Q packet follows a D packet (shown in the left half of the figure), a gap ( $t_{CAC}-t_{CWD}$ ) will automatically appear between them because the  $t_{CWD}$  value is always less than the  $t_{CAC}$  value. There will be no gap between the two COLC packets with the WR and RD commands which schedule the D and Q packets.

When a D packet follows a Q packet (shown in the right half of the figure), no gap is needed between them because the  $t_{CWD}$  value is less than the  $t_{CAC}$  value. However, a gap of  $t_{CAC} - t_{CWD}$  or greater must be inserted between the COLC packets with the RD WR commands by the controller so the Q and D packets do not overlap.

Figure 4-1 Read (Q) and Write (D) Data Packet - Timing for  $t_{CAC} = 8,9,10,11$  or  $12 t_{CYCLE}$

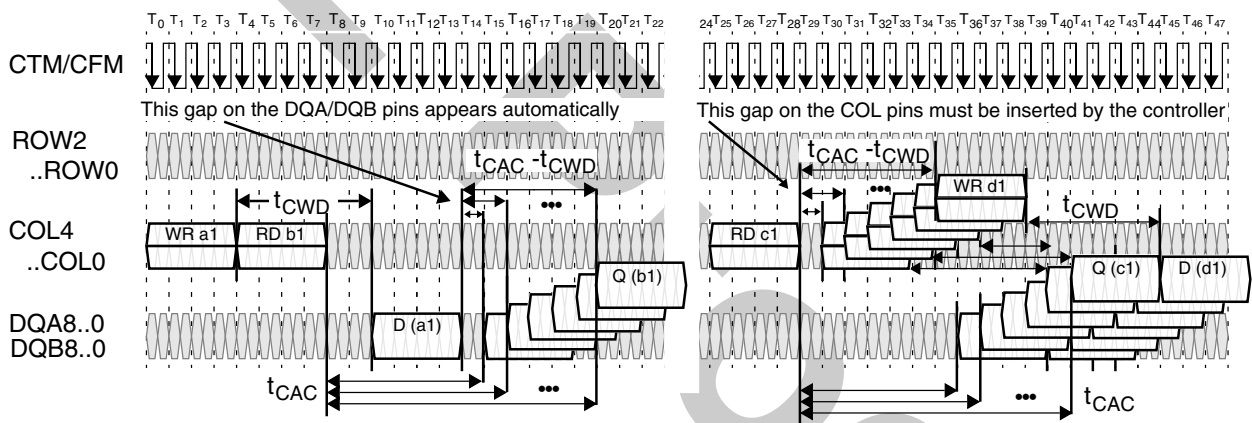

### 5. COLM Packet to D Packet Mapping

Figure 5-1 shows a write operation initiated by a WR command in a COLC packet. If a subset of the 16 bytes of write data are to be written, then a COLM packet is transmitted on the COL pins a time  $t_{RTR}$  after the COLC packet containing the WR command. The M bit of the COLM packet is set to indicate that it contains the MA and MB mask fields. Note that this COLM packet is aligned with the COLC packet which causes the write buffer to be retired. See Figure 15-1 for more details.

If all 16 bytes of the D data packet are to be written, then no further control information is required. The packet slot that would have been used by the COLM packet ( $t_{RTR}$  after the COLC packet) is available to be used as an COLX packet. This could be used for a PREX precharge command or for a housekeeping command (this case is not shown). The M bit is not asserted in an COLX packet and causes all 16 bytes of the previous WR to be written unconditionally. Note that a RD command will never need a COLM packet, and will always be able to use the COLX packet option (a read operation has no need for the byte-write-enable control bits).

The figure 5-1 also shows the mapping between the MA and MB fields of the COLM packet and bytes of the D packet on the DQA and DQB pins. Each mask bit controls whether a byte of data is written (=1) or not written (=0).

Figure 5-1 Mapping between COLM Packet and D Packet for WR Command

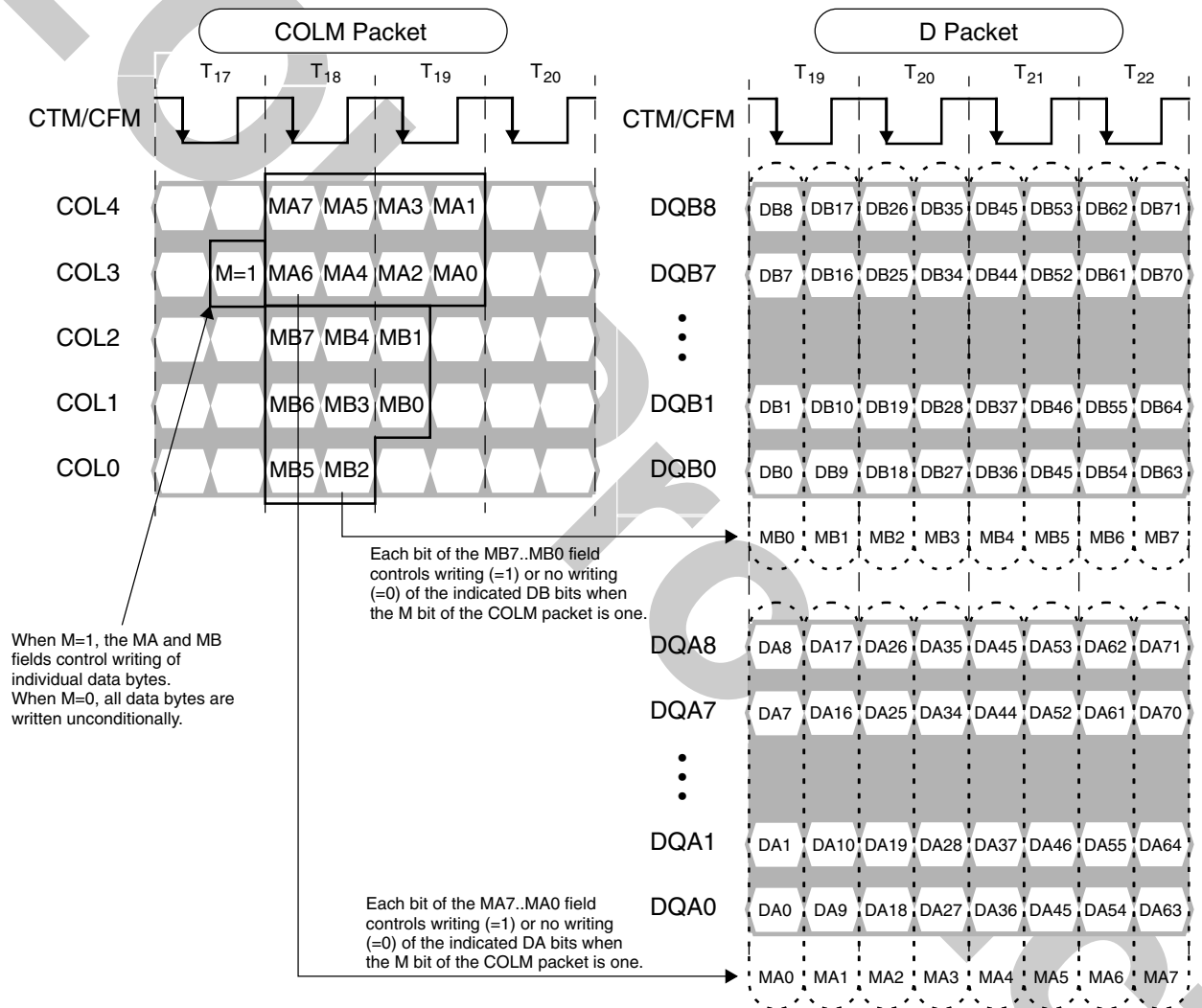
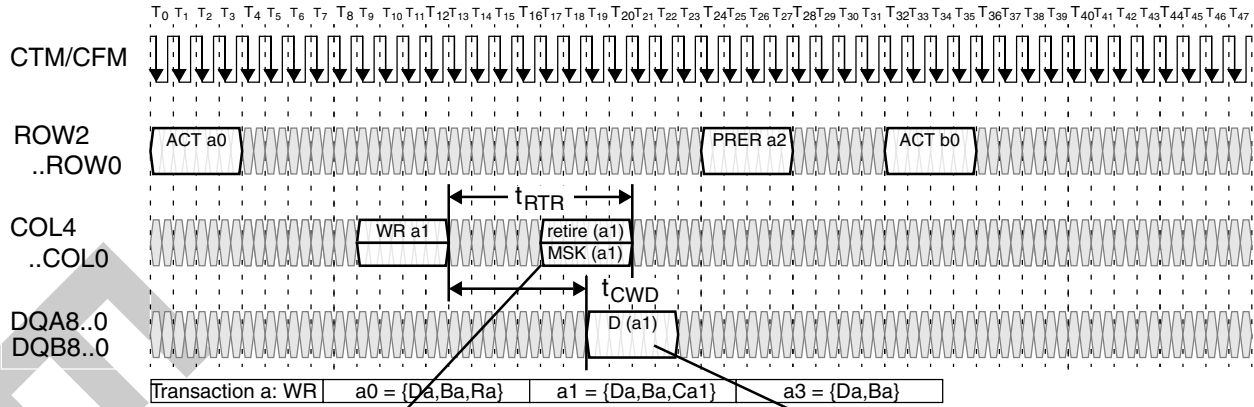

### 6. ROW-to-ROW Packet Interaction

Figure 6-1 shows two packets on the ROW pins separated by an interval  $t_{RRDELAY}$  which depends upon the packet contents. No other ROW packets are sent to banks {Ba, Ba+1, Ba-1} between packet “a” and packet “b” unless noted otherwise.

Figure 6-1 ROW-to-ROW Packet Interaction - Timing

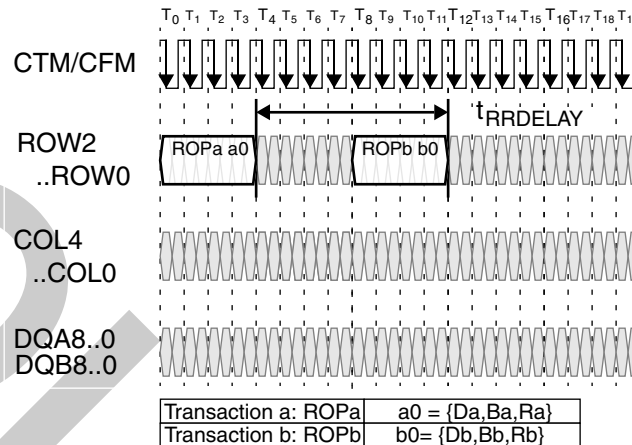

Table 6-1 summarizes the  $t_{RRDELAY}$  values for all possible cases.

Cases RR1 through RR4 show two successive ACT commands. In case RR1, there is no restriction since the ACT commands are to different devices. In case RR2, the  $t_{RR}$  restriction applies to the same device with non-adjacent banks. Cases RR3 and RR4 are illegal (as shown) since bank Ba needs to be precharged. If a PRER to Ba, Ba+1, or Ba-1 is inserted,  $t_{RRDELAY}$  is  $t_{RC}$  ( $t_{RAS}$  to the PRER command, and  $t_{RP}$  to the next ACT).

Cases RR5 through RR8 show an ACT command followed by a PRER command. In cases RR5 and RR6, there are no restrictions since the commands are to different devices or to non-adjacent banks of the same device. In cases RR7 and RR8, the  $t_{RAS}$  restriction means the activated bank must wait before it can be precharged.

Cases RR9 through RR12 show a PRER command followed by an ACT command. In cases RR9 and RR10, there are essentially no restrictions since the commands are to different devices or to non-adjacent banks of the same device. RR10a and RR10b depend upon whether a bracketed bank (Ba+1) is precharged or activated. In cases RR11 and RR12, the same and adjacent banks must all wait  $t_{RP}$  for the sense amp and bank to precharge before being activated.

Cases RR13 through RR16 summarize the combinations of two successive PRER commands. In case RR13 there is no restriction since two devices are addressed. In RR14,  $t_{PP}$  applies, since the same device is addressed. In RR15 and RR16, the same bank or an adjacent bank may be given repeated PRER commands with only the  $t_{PP}$  restriction.

Two adjacent banks can't be activate simultaneously. A precharge command to one bank will thus affect the state of the adjacent banks (and sense amps). If bank Ba is activate and a PRER is directed to Ba, then bank Ba will be precharged along with sense amps Ba-1/Ba and Ba/Ba+1. If bank Ba+1 is activate and a PRER is directed to Ba, then bank Ba+1 will be precharged along with sense amps Ba/Ba+1 and Ba+1/Ba+2. If bank Ba-1 is activate and a PRER is directed to Ba, then bank Ba-1 will be precharged along with sense amps Ba/Ba-1 and Ba-1/Ba-2.

A ROW packet may contain commands other than ACT or PRER. The REFA and REFP commands are equivalent to ACT and PRER for interaction analysis purposes. The interaction rules of the NAPR, NAPRC, PDNR, RLXR, ATTN, TCAL, and TCEN commands are discussed in later section (see Table 3-2 for cross-ref).



Table 6-1 ROW-to-ROW Packet Interaction - Rules

Case #	ROPa	Da	Ba	Ra	ROPb	Db	Bb	Rb	tRRDELAY	Example
RR1	ACT	Da	Ba	Ra	ACT	/= Da	xxxx	X..X	tPACKET	Figure 10-2
RR2	ACT	Da	Ba	Ra	ACT	== Da	/= {Ba, Ba+1, Ba-1}	X..X	tRR	Figure 10-2
RR3	ACT	Da	Ba	Ra	ACT	== Da	== {Ba+1, Ba-1}	X..X	tRC - illegal unless PRER to Ba / Ba+1 / Ba-1	Figure 10-1
RR4	ACT	Da	Ba	Ra	ACT	== Da	== {Ba}	X..X	tRC - illegal unless PRER to Ba / Ba+1 / Ba-1	Figure 10-1
RR5	ACT	Da	Ba	Ra	PRER	/= Da	xxxx	X..X	tPACKET	Figure 10-2
RR6	ACT	Da	Ba	Ra	PRER	== Da	/= {Ba, Ba+1, Ba-1}	X..X	tPACKET	Figure 10-2
RR7	ACT	Da	Ba	Ra	PRER	== Da	== {Ba+1, Ba-1}	X..X	tRAS	Figure 10-1
RR8	ACT	Da	Ba	Ra	PRER	== Da	== {Ba}	X..X	tRAS	Figure 13-1
RR9	PRER	Da	Ba	Ra	ACT	/= Da	xxxx	X..X	tPACKET	Figure 10-3
RR10	PRER	Da	Ba	Ra	ACT	== Da	/= {Ba, Ba+1, Ba-2}	X..X	tPACKET	Figure 10-3
RR10a	PRER	Da	Ba	Ra	ACT	== Da	== {Ba+2}	X..X	tPACKET/tRP if Ba+1 is precharged/activated.	
RR10b	PRER	Da	Ba	Ra	ACT	== Da	== {Ba-2}	X..X	tPACKET/tRP if Ba-1 is precharged/activated.	
RR11	PRER	Da	Ba	Ra	ACT	== Da	== {Ba+1, Ba-1}	X..X	tRP	Figure 10-1
RR12	PRER	Da	Ba	Ra	ACT	== Da	== {Ba}	X..X	tRP	Figure 10-1
RR13	PRER	Da	Ba	Ra	PRER	/= Da	xxxx	X..X	tPACKET	Figure 10-3
RR14	PRER	Da	Ba	Ra	PRER	== Da	/= {Ba, Ba+1, Ba-1}	X..X	tPP	Figure 10-3
RR15	PRER	Da	Ba	Ra	PRER	== Da	== {Ba+1, Ba-1}	X..X	tPP	Figure 10-3
RR16	PRER	Da	Ba	Ra	PRER	== Da	== {Ba}	X..X	tPP	Figure 10-3

7. ROW-to-COL Packet Interaction

Figure 7-1 shows two packets on the ROW and COL pins. They must be separated by an interval  $t_{RCDELAY}$  which depends upon the packet contents.

Figure 7-1 ROW-to-COL Packet Interaction- Timing

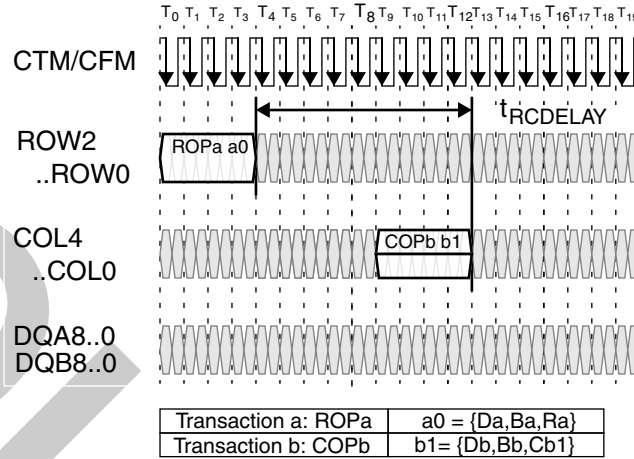

Table 7-1 summarizes the  $t_{RCDELAY}$  values for all possible cases. Note that if the COL packet is earlier than the ROW packet, it is considered a COL-to-ROW packet interaction.

Cases RC1 through RC5 summarize the rules when the ROW packet has an ACT command. Figure 13-1 and Figure 14-1 show examples of RC5 - an activation followed by a read or write. RC4 is an illegal situation, since a read or write of a precharged banks is being attempted (remember that for a bank to be activated, adjacent banks must be precharged). In cases RC1, RC2, and RC3, there is no interaction of the ROW and COL packets.

Cases RC6 through RC8 summarize the rules when the ROW packet has a PRER command. There is either no interaction (RC6 through RC9) or an illegal situation with a read or write of a precharged bank (RC9).

The COL pins can also schedule a precharge operation with a RDA, WRA, or PREC command in a COLC packet or a PREX command in a COLX packet. The constraints of these precharge operations may be converted to equivalent PRER command constraints using the rules summarized in Figure 12-2.

Table 7-1 ROW-to-COL Packet Interaction - Rules

Case #	ROPa	Da	Ba	Ra	COPb	Db	Bb	Cb1	$t_{RCDELAY}$	Example
RC1	ACT	Da	Ba	Ra	NOCOP, RD, retire	/= Da	xxxx	x..x	0	
RC2	ACT	Da	Ba	Ra	NOCOP	== Da	xxxx	x..x	0	
RC3	ACT	Da	Ba	Ra	RD, retire	== Da	/= {Ba, Ba+1, Ba-1}	x..x	0	
RC4	ACT	Da	Ba	Ra	RD, retire	== Da	== {Ba+1, Ba-1}	x..x	Illegal	
RC5	ACT	Da	Ba	Ra	RD, retire	== Da	== {Ba}	x..x	$t_{RC}$	Figure 13-1
RC6	PRER	Da	Ba	Ra	NOCOP, RD, retire	/= Da	xxxx	x..x	0	
RC7	PRER	Da	Ba	Ra	NOCOP	== Da	xxxx	x..x	0	
RC8	PRER	Da	Ba	Ra	RD, retire	== Da	/= {Ba, Ba+1, Ba-1}	x..x	0	
RC9	PRER	Da	Ba	Ra	RD, retire	== Da	== {Ba+1, Ba-1}	x..x	Illegal	

8. COL-to-COL Packet Interaction

Figure 8-1 shows three arbitrary packets on the COL pins. Packets “b” and “c” must be separated by an interval  $t_{CCDELAY}$  which depends upon the command and address values in all three packets. Table 8-1 summarizes the  $t_{CCDELAY}$  values for all possible cases.

Cases CC1 through CC5 summarize the rules for every situation other than the case when COPb is a WR command and COPc is a RD command. In CC3, when a RD command is followed by a WR command, a gap of  $t_{CAC} - t_{CWD}$  must be inserted between the two COL packets. See Figure 4-1 for more explanation of why this gap is needed. For cases CC1, CC2, CC4, and CC5, there is no restriction ( $t_{CCDELAY}$  is  $t_{CC}$ ).

In cases CC6 through CC10, COPb is a WR command and COPc is a RD command. The  $t_{CCDELAY}$  value needed between these two packets depends upon the command and address in the packet with COPa. In particular, in case CC6 when there is WR-WR-RD command sequence directed to the same device, a gap will be needed between the packets with COPb and COPc. The gap will need a COLC packet with a NOCOP command directed to any device in order to force an automatic retire to take place. Figure 15-2 (right) provides a more detailed explanation of this case.

Cases CC7, CC8, CC9 and CC10 have no restriction ( $t_{CCDELAY}$  is  $t_{CC}$ ).

For the purposes of analyzing COL-to-ROW interactions, the PREC, WRA, and RDA commands of the COLC packet are equivalent to the NOCOP, WR, and RD commands. These commands also cause a precharge operation PREC to take place. This precharge may be converted to an equivalent PRER command on the ROW pins using the rules summarized in Figure 12-2.

Figure 8-1 COL-to-COL Packet Interaction- Timing

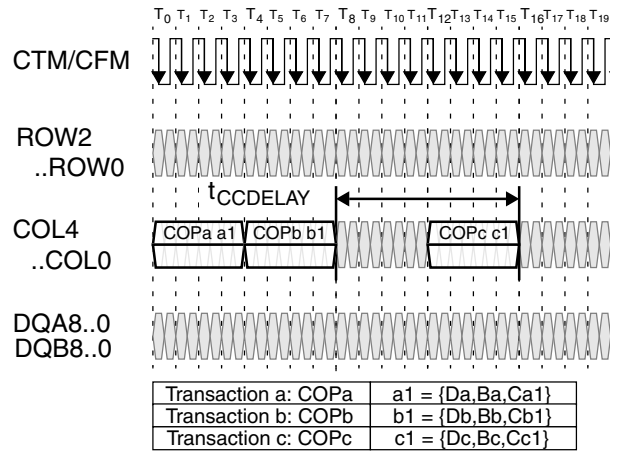

Table 8-1 COL-to-COL Packet Interaction - Rules

Case #	COPa	Da	Ba	Ca1	COPb	Db	Bb	Cb1	COPc	Dc	Bc	Cc1	$t_{CCDELAY}$	Example
CC1	xxxx	xxxxx	x..x	x..x	NOCOP	Db	Bb	Cb1	xxxx	xxxxx	x..x	x..x	$t_{CC}$	
CC2	xxxx	xxxxx	x..x	x..x	RD, WR	Db	Bb	Cb1	NOCOP	xxxxx	x..x	x..x	$t_{CC}$	
CC3	xxxx	xxxxx	x..x	x..x	RD	Db	Bb	Cb1	WR	xxxxx	x..x	x..x	$t_{CC} + t_{CAC} - t_{CWD}$	Figure 4-1
CC4	xxxx	xxxxx	x..x	x..x	RD	Db	Bb	Cb1	RD	xxxxx	x..x	x..x	$t_{CC}$	Figure 13-1
CC5	xxxx	xxxxx	x..x	x..x	WR	Db	Bb	Cb1	WR	xxxxx	x..x	x..x	$t_{CC}$	Figure 14-1
CC6	WR	== Db	x	x..x	WR	Db	Bb	Cb1	RD	== Db	x..x	x..x	$t_{RTR}$	Figure 15-1
CC7	WR	== Db	x	x..x	WR	Db	Bb	Cb1	RD	/= Db	x..x	x..x	$t_{CC}$	
CC8	WR	/= Db	x	x..x	WR	Db	Bb	Cb1	RD	== Db	x..x	x..x	$t_{CC}$	
CC9	NOCOP	== Db	x	x..x	WR	Db	Bb	Cb1	RD	== Db	x..x	x..x	$t_{CC}$	
CC10	RD	== Db	x	x..x	WR	Db	Bb	Cb1	RD	== Db	x..x	x..x	$t_{CC}$	

9. COL-to-ROW Packet Interaction

Figure 9-1 shows arbitrary packets on the COL and ROW pins. They must be separated by an interval  $t_{CRDELAY}$  which depends upon the command and address values in the packets. Table 9-1 summarizes the  $t_{CRDELAY}$  value for all possible cases.

Cases CR1, CR2, CR3, and CR9 show no interaction between the COL and ROW packets, either because one of the commands is a NOP or because the packets are directed to different devices or to non-adjacent banks.

Case CR4 is illegal because an already-activated bank is to be re-activated without being precharged. Case CR5 is illegal because an adjacent bank can't be activated or precharged until bank Ba is precharged first.

In case CR6, the COLC packet contains a RD command, and the ROW packet contains a PRER command for the same bank. The  $t_{RDP}$  parameter specifies the required spacing.

Likewise, in case CR7, the COLC packet causes an automatic retire to take place, and the ROW packet contains a PRER command for the same bank. The  $t_{RTP}$  parameter specifies the required spacing.

Case CR8 is labeled "Hazardous" because a WR command should always be followed by an automatic retire before a precharge is scheduled. Figure 15-3 shows an example of what can happen when the retire is not able to happen before the precharge.

For the purposes of analyzing COL-to-ROW interactions, the PREC, WRA, and RDA commands of the COLC packet are equivalent to the NOCOP, WR, and RD commands. These commands also cause a precharge operation to take place. This precharge may be converted to an equivalent PRER command on the ROW pins using the rules summarized in Figure 12-2.

A ROW packet may contain commands other than ACT or PRER. The REFA and REFP commands are equivalent to ACT and PRER for interaction analysis purposes. The interaction rules of the NAPR, PDNR, and RLXR commands are discussed in a later section.

Figure 9-1 COL-to-ROW Packet Interaction- Timing

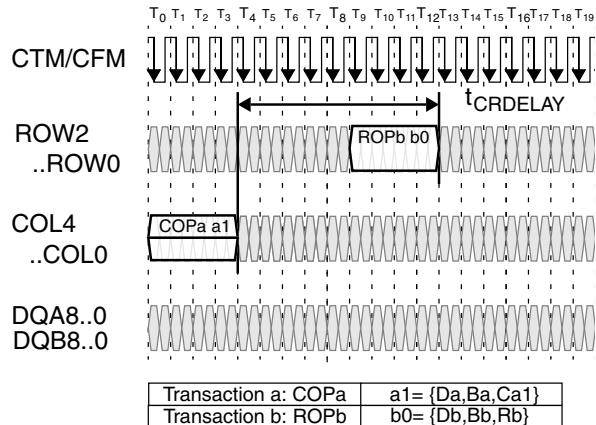

Table 9-1 COL-to-ROW Packet Interaction - Rules

Case #	COPa	Da	Ba	Ca1	ROPb	Db	Bb	Rb	$t_{CRDELAY}$	Example
CR1	NOCOP	Da	Ba	Ca1	x..x	xxxxx	xxxxx	x..x	0	
CR2	RD/WR	Da	Ba	Ca1	x..x	/= Da	xxxxx	x..x	0	
CR3	RD/WR	Da	Ba	Ca1	x..x	== Da	/= {Ba, Ba+1, Ba-1}	x..x	0	
CR4	RD/WR	Da	Ba	Ca1	ACT	== Da	== {Ba}	x..x	Illegal	
CR5	RD/WR	Da	Ba	Ca1	ACT	== Da	== {Ba+1, Ba-1}	x..x	Illegal	
CR6	RD	Da	Ba	Ca1	PRER	== Da	== {Ba, Ba+1, Ba-1}	x..x	$t_{RDP}$	Figure 13-1
CR7	retire <sup>Note 1</sup>	Da	Ba	Ca1	PRER	== Da	== {Ba, Ba+1, Ba-1}	x..x	$t_{RTP}$	Figure 14-1
CR8	WR <sup>Note 2</sup>	Da	Ba	Ca1	PRER	== Da	== {Ba, Ba+1, Ba-1}	x..x	0	Figure 15-3
CR9	xxxx	Da	Ba	Ca1	NOROP	xxxxx	xxxxx	x..x	0	

**Notes 1.** This is any command which permits the write buffer of device Da to retire (see Table 3-3). "Ba" is the bank address in the write buffer.

**2.** This situation is hazardous because the write buffer will be left unretired while the targeted bank is precharged. See Figure 15-3.

10. ROW-to-ROW Examples

Figure 10-1 shows examples of some of the ROW-to-ROW packet spacings from Table 6-1. A complete sequence of activate and precharge commands is directed to a bank. The RR8 and RR12 rules apply to this sequence. In addition to satisfying the  $t_{RAS}$  and  $t_{RP}$  timing parameters, the separation between ACT commands to the same bank must also satisfy the  $t_{RC}$  timing parameter (RR4).

When a bank is activated, it is necessary for adjacent banks to remain precharged. As a result, the adjacent banks will also satisfy parallel timing constraints; in the example, the RR11 and RR3 rules are analogous to the RR12 and RR4 rules.

Figure 10-1 Row Packet Example

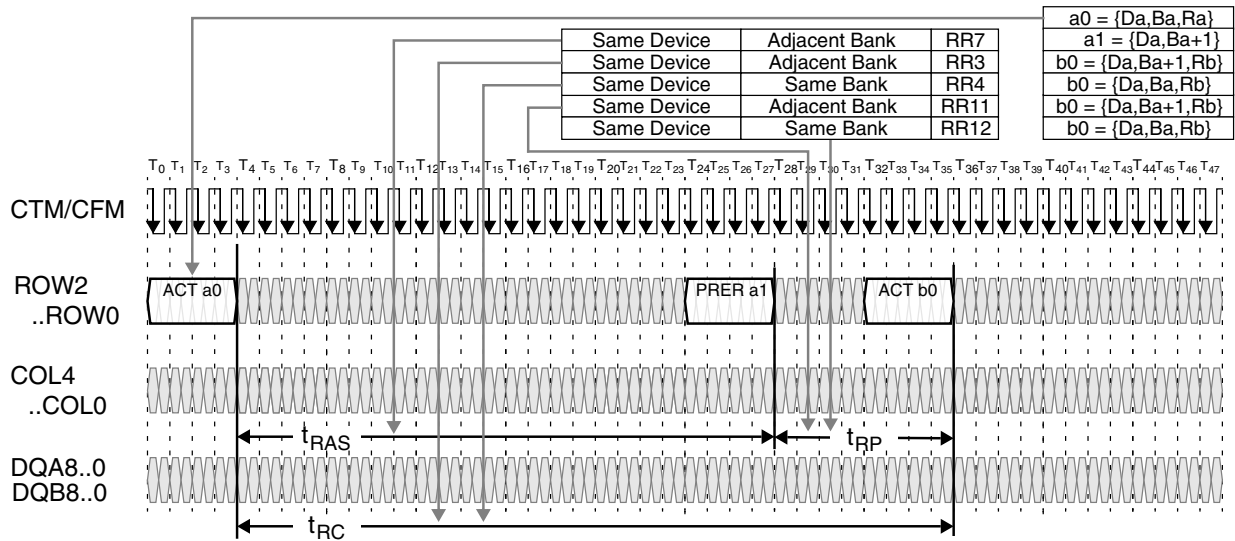

Figure 10-2 shows examples of the ACT-to-ACT (RR1, RR2) and ACT-to-PRER (RR5, RR6) command spacings from Table 6-1. In general, the commands in ROW packets may be spaced an interval  $t_{PACKET}$  apart unless they are directed to the same or adjacent banks or unless they are a similar command type (both PRER or both ACT) directed to the same device.

Figure 10-2 Row Packet Example

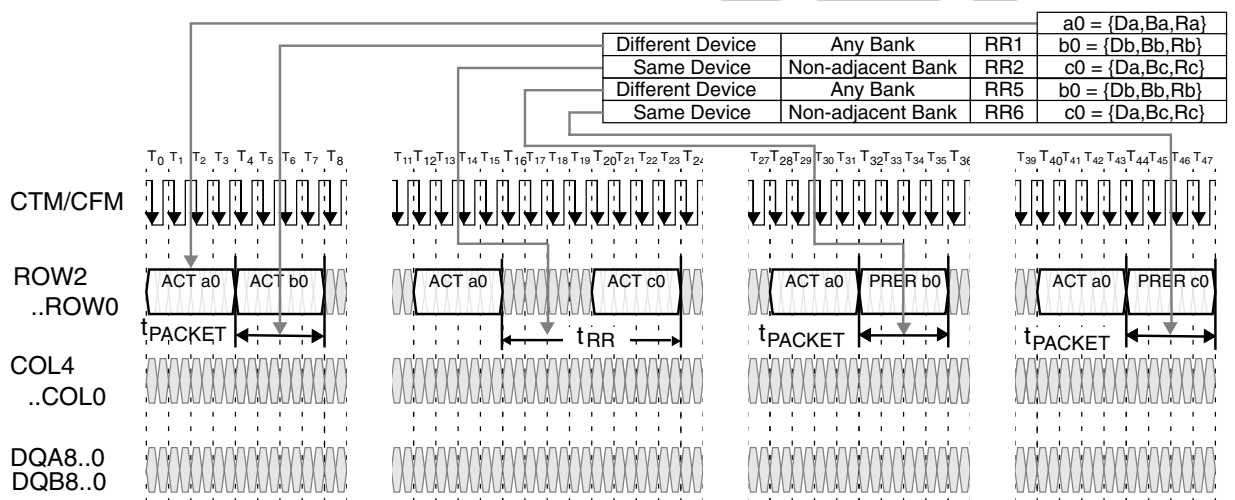
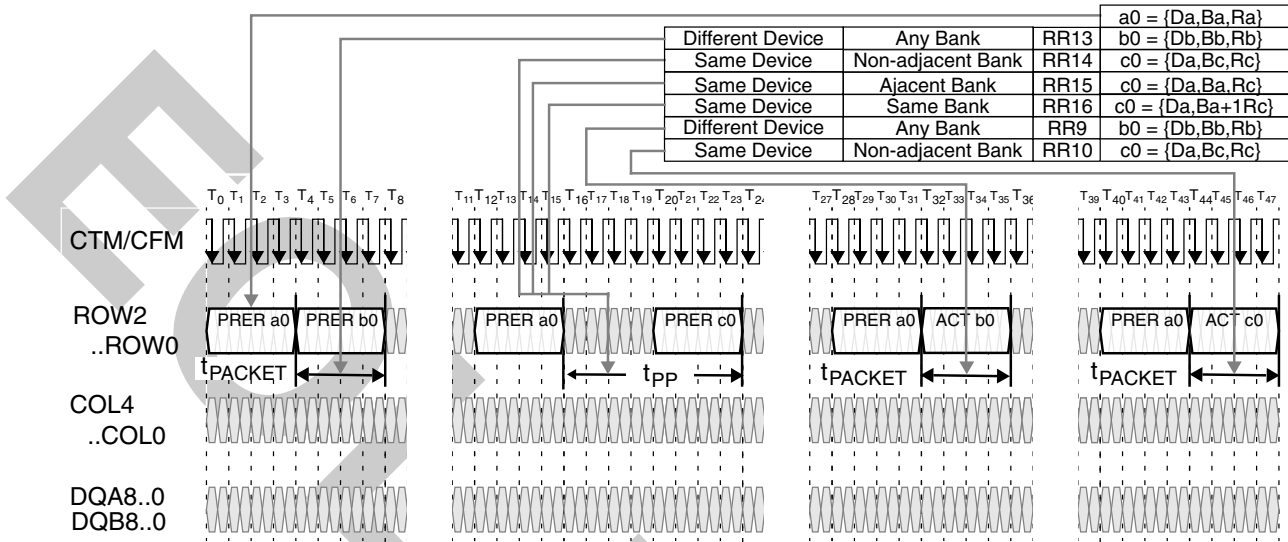

Figure 10-3 shows examples of the PRER-to-PRER (RR13, RR14) and PRER-to-ACT (RR9, RR10) command spacings from Table 6-1. The RR15 and RR16 cases (PRER-to-PRER to same or adjacent banks) are not shown, but are similar to RR14. In general, the commands in ROW packets may be spaced an interval  $t_{PACKET}$  apart unless they are directed to the same or adjacent banks or unless they are a similar command type (both PRER or both ACT) directed to the same device.

Figure 10-3 Row Packet Example



### 11. Row and Column Cycle Description

**Activate:** A row cycle begins with the activate (ACT) operation. The activation process is destructive; the act of sensing the value of a bit in a bank’s storage cell transfers the bit to the sense amp, but leaves the original bit in the storage cell with an incorrect value.

**Restore:** Because the activation process is destructive, a hidden operation called restore is automatically performed. The restore operation rewrites the bits in the sense amp back into the storage cells of the activated row of the bank.

**Read/Write:** While the restore operation takes place, the sense amp may be read (RD) and written (WR) using column operations. If new data is written into the sense amp, it is automatically forwarded to the storage cells of the bank so the data in the activated row and the data in the sense amp remain identical.

**Precharge:** When both the restore operation and the column operations are completed, the sense amp and bank are precharged (PRE). This leaves them in the proper state to begin another activate operation.

**Intervals:** The activate operation requires the interval  $t_{RCD,MIN}$  to complete. The hidden restore operation requires the interval  $t_{RAS,MIN} - t_{RCD,MIN}$  to complete. Column read and write operations are also performed during the  $t_{RAS,MIN} - t_{RCD,MIN}$  interval (if more than about four column operations are performed, this interval must be increased). The precharge operation requires the interval  $t_{RP,MIN}$  to complete.

**Adjacent Banks:** An RDRAM device with a “s” designation (512K x 18 x 32s) indicates it contains “split banks”. This means the sense amps are shared between two adjacent banks. When a row in a bank is activated, the two adjacent sense amps are connected to (associated with) that bank and are not available for use by the two adjacent banks. These two adjacent banks must remain precharged while the selected bank goes through its activate, restore, read/write, and precharge operations.

For example (referring to the block diagram), if bank 5 is accessed, sense amp 4/5 and sense amp 5/6 will both be loaded with one of the 512 rows (with 1,024 bytes loaded into each sense amp from the 2K byte row – 512 bytes to the DQA side and 512 bytes to the DQB side). While this row from bank 5 is being accessed, no rows may be accessed in banks 4 or 6 because of the sense amp sharing.

12. Precharge Mechanisms

Figure 12-1 shows an example of precharge with the ROWR packet mechanism. The PRER command must occur a time  $t_{RAS}$  after the ACT command, and a time  $t_{RP}$  before the next ACT command. This timing will serve as a baseline against which the other precharge mechanisms can be compared.

Figure 12-1 Precharge via PRER Command in ROWR Packet

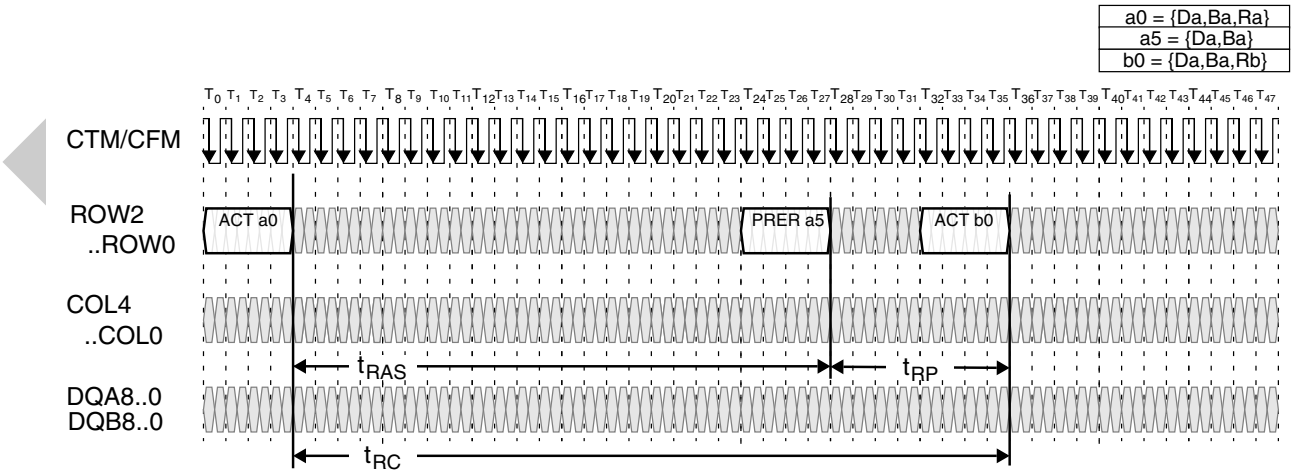

Figure 12-2 (top) shows an example of precharge with a RDA command. A bank is activated with an ROWA packet on the ROW pins. Then, a series of four dualocts are read with RD commands in COLC packets on the COL pins. The fourth of these commands is a RDA, which causes the bank to automatically precharge when the final read has finished. The timing of this automatic precharge is equivalent to a PRER command in an ROWR packet on the ROW pins that is offset a time  $t_{OFFP}$  from the COLC packet with the RDA command. The RDA command should be treated as a RD command in a COLC packet as well as a simultaneous (but offset) PRER command in an ROWR packet when analyzing interactions with other packets.

Figure 12-2 (middle) shows an example of precharge with a WRA command. As in the RDA example, a bank is activated with an ROWA packet on the ROW pins. Then, two dualocts are written with WR commands in COLC packets on the COL pins. The second of these commands is a WRA, which causes the bank to automatically precharge when the final write has been retired. The timing of this automatic precharge is equivalent to a PRER command in an ROWR packet on the ROW pins that is offset a time  $t_{OFFP}$  from the COLC packet that causes the automatic retire. The WRA command should be treated as a WR command in a COLC packet as well as a simultaneous (but offset) PRER command in an ROWR packet when analyzing interactions with other packets. Note that the automatic retire is triggered by a COLC packet a time  $t_{RTR}$  after the COLC packet with the WR command unless the second COLC contains a RD command to the same device. This is described in more detail in Figure 15-1.

Figure 12-2 (bottom) shows an example of precharge with a PREX command in an COLX packet. A bank is activated with an ROWA packet on the ROW pins. Then, a series of four dualocts are read with RD commands in COLC packets on the COL pins. The fourth of these COLC packets includes an COLX packet with a PREX command. This causes the bank to precharge with timing equivalent to a PRER command in an ROWR packet on the ROW pins that is offset a time  $t_{OFFP}$  from the COLX packet with the PREX command.

Figure 12-2 Offsets for Alternate Precharge Mechanisms

**COLC Packet: RDA Precharge Offset**

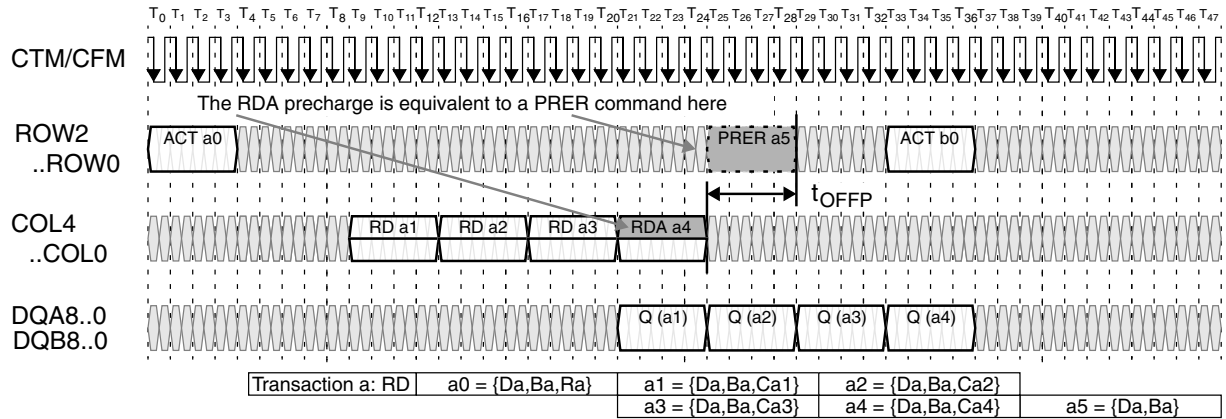

**COLC Packet: WDA Precharge Offset**

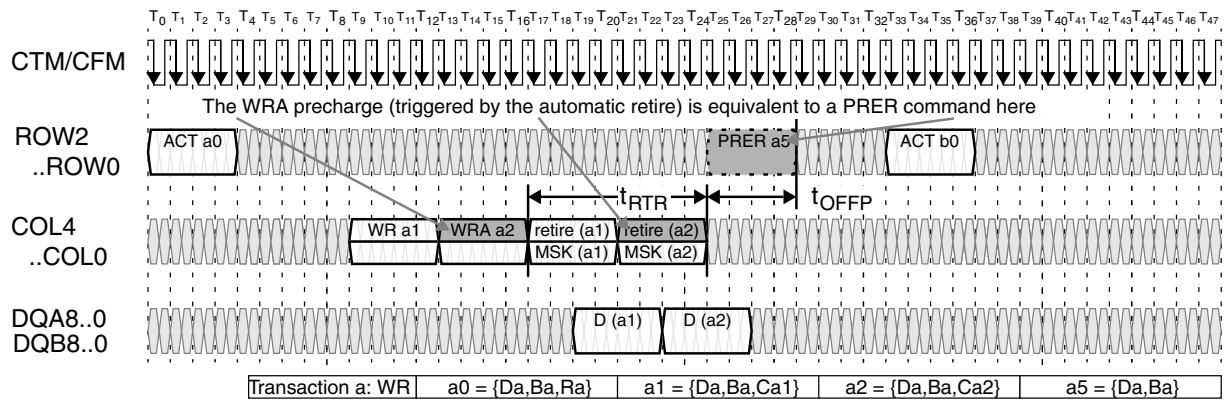

**COLX Packet: PREX Precharge Offset**

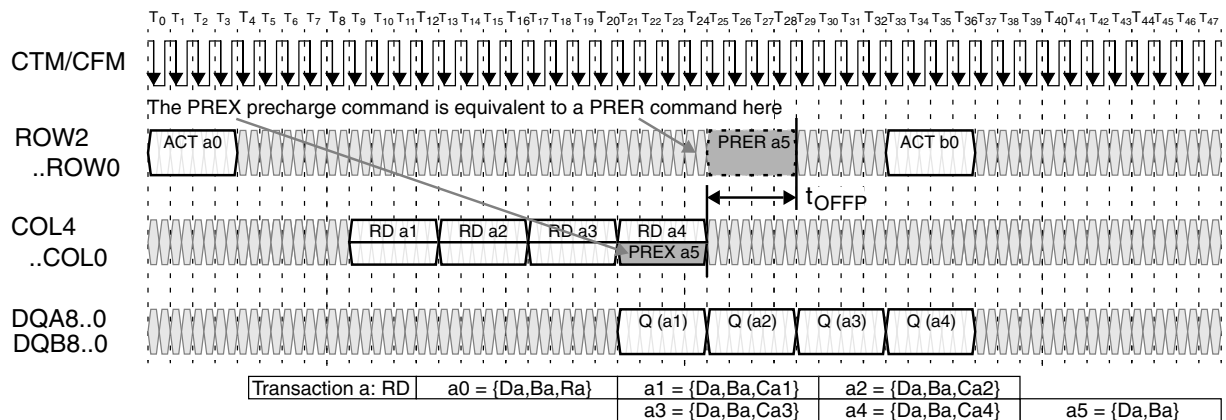



### 13. Read Transaction - Example

Figure 13-1 shows an example of a read transaction. It begins by activating a bank with an ACT a0 command in an ROWA packet. A time  $t_{RCD}$  later a RD a1 command is issued in a COLC packet. Note that the ACT command includes the device, bank, and row address (abbreviated as a0) while the RD command includes device, bank, and column address (abbreviated as a1). A time  $t_{CAC}$  after the RD command the read data dualoct Q (a1) is returned by the device. Note that the packets on the ROW and COL pins use the end of the packet as a timing reference point, while the packets on the DQA/DQB pins use the beginning of the packet as a timing reference point.

A time  $t_{CC}$  after the first COLC packet on the COL pins a second is issued. It contains a RD a2 command. The a2 address has the same device and bank address as the a1 address (and a0 address), but a different column address. A time  $t_{CAC}$  after the second RD command a second read data dualoct Q(a2) is returned by the device.

Next, a PRER a3 command is issued in an ROWR packet on the ROW pins. This causes the bank to precharge so that a different row may be activated in a subsequent transaction or so that an adjacent bank may be activated. The a3 address includes the same device and bank address as the a0, a1, and a2 addresses. The PRER command must occur a time  $t_{RAS}$  or more after the original ACT command (the activation operation in any DRAM is destructive, and the contents of the selected row must be restored from the two associated sense amps of the bank during the  $t_{RAS}$  interval). The PRER command must also occur a time  $t_{RDP}$  or more after the last RD command. Note that the  $t_{RDP}$  value shown is greater than the  $t_{RDP,MIN}$  specification in "36.Timing Parameters". This transaction example reads two dualocts, but there is actually enough time to read three dualocts before  $t_{RDP}$  becomes the limiting parameter rather than  $t_{RAS}$ . If four dualocts were read, the packet with PRER would need to shift right (be delayed) by one  $t_{CYCLE}$  (note-this case is not shown).

Finally, an ACT b0 command is issued in an ROWR packet on the ROW pins. The second ACT command must occur a time  $t_{RC}$  or more after the first ACT command and a time  $t_{RP}$  or more after the PRER command. This ensures that the bank and its associated sense amps are precharged. This example assumes that the second transaction has the same device and bank address as the first transaction, but a different row address. Transaction b may not be started until transaction a has finished. However, transactions to other banks or other devices may be issued during transaction a.

Figure 13-1 Read Transaction Example

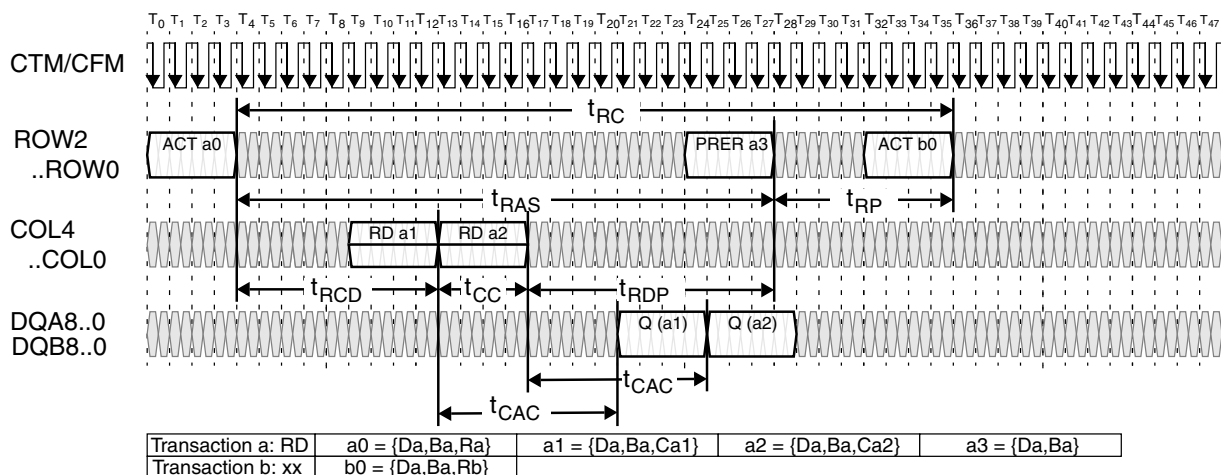

14. Write Transaction - Example

Figure 14-1 shows an example of a write transaction. It begins by activating a bank with an ACT a0 command in an ROWA packet. A time  $t_{RCD} - t_{RTR}$  later a WR a1 command is issued in a COLC packet (note that the  $t_{RCD}$  interval is measured to the end of the COLC packet with the first retire command). Note that the ACT command includes the device, bank, and row address (abbreviated as a0) while the WR command includes device, bank, and column address (abbreviated as a1). A time  $t_{CWD}$  after the WR command the write data dualoct D(a1) is issued. Note that the packets on the ROW and COL pins use the end of the packet as a timing reference point, while the packets on the DQA/DQB pins use the beginning of the packet as a timing reference point.

A time  $t_{CC}$  after the first COLC packet on the COL pins a second COLC packet is issued. It contains a WR a2 command. The a2 address has the same device and bank address as the a1 address (and a0 address), but a different column address. A time  $t_{CWD}$  after the second WR command a second write data dualoct D(a2) is issued.

A time  $t_{RTR}$  after each WR command an optional COLM packet MSK (a1) is issued, and at the same time a COLC packet is issued causing the write buffer to automatically retire. See Figure 15-1 for more detail on the write/retire mechanism. If a COLM packet is not used, all data bytes are unconditionally written. If the COLC packet which causes the write buffer to retire is delayed, then the COLM packet (if used) must also be delayed.

Next, a PRER a3 command is issued in an ROWR packet on the ROW pins. This causes the bank to precharge so that a different row may be activated in a subsequent transaction or so that an adjacent bank may be activated. The a3 address includes the same device and bank address as the a0, a1, and a2 addresses. The PRER command must occur a time  $t_{RAS}$  or more after the original ACT command (the activation operation in any DRAM is destructive, and the contents of the selected row must be restored from the two associated sense amps of the bank during the  $t_{RAS}$  interval).

A PRER a3 command is issued in an ROWR packet on the ROW pins. The PRER command must occur a time  $t_{RTP}$  or more after the last COLC which causes an automatic retire.

Finally, an ACT b0 command is issued in an ROWR packet on the ROW pins. The second ACT command must occur a time  $t_{RC}$  or more after the first ACT command and a time  $t_{RP}$  or more after the PRER command. This ensures that the bank and its associated sense amps are precharged. This example assumes that the second transaction has the same device and bank address as the first transaction, but a different row address. Transaction b may not be started until transaction a has finished. However, transactions to other banks or other devices may be issued during transaction a.

Figure 14-1 Write Transaction Example

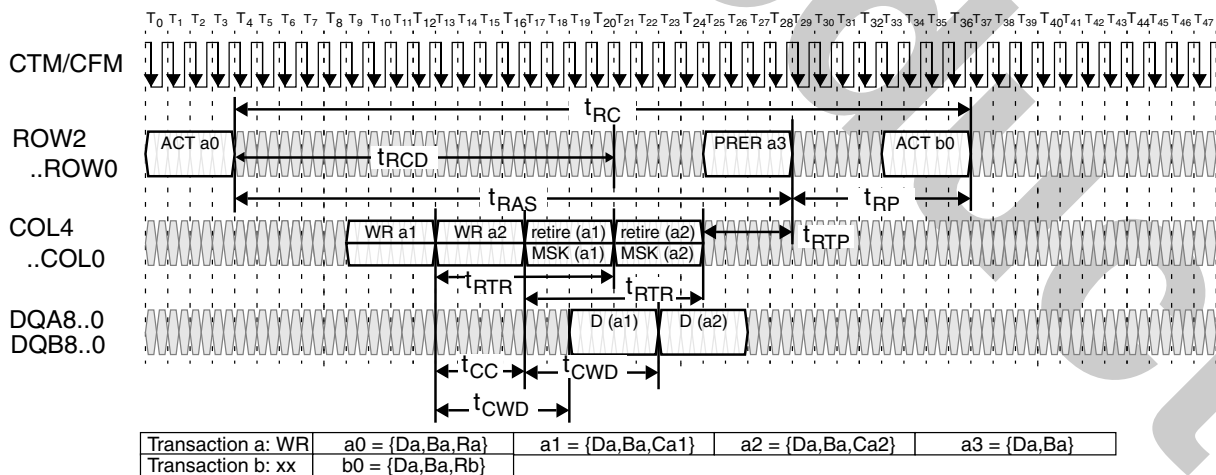

15. Write/Retire - Examples

The process of writing a dualoct into a sense amp of an RDRAM bank occurs in two steps. The first step consists of transporting the write command, write address, and write data into the write buffer. The second step happens when the RDRAM device automatically retires the write buffer (with an optional bytemask) into the sense amp. This two-step write process reduces the natural turn-around delay due to the internal bidirectional data pins.

Figure 15-1 (left) shows an example of this two step process. The first COLC packet contains the WR command and an address specifying device, bank and column. The write data dualoct follows a time  $t_{CWD}$  later. This information is loaded into the write buffer of the specified device. The COLC packet which follows a time  $t_{RTR}$  later will retire the write buffer. The retire will happen automatically unless (1) a COLC packet is not framed (no COLC packet is present and the S bit is zero), or (2) the COLC packet contains a RD command to the same device. If the retire does not take place at time  $t_{RTR}$  after the original WR command, then the device continues to frame COLC packets, looking for the first that is not a RD directed to itself. A bytemask  $MSK(a1)$  may be supplied in a COLM packet aligned with the COLC that retires the write buffer at time  $t_{RTR}$  after the WR command.

The memory controller must be aware of this two-step write/retire process. Controller performance can be improved, but only if the controller design accounts for several side effects.

Figure 15-1 (right) shows the first of these side effects. The first COLC packet has a WR command which loads the address and data into the write buffer. The third COLC causes an automatic retire of the write buffer to the sense amp. The second and fourth COLC packets (which bracket the retire packet) contain RD commands with the same device, bank and column address as the original WR command. In other words, the same dualoct address that is written is read both before and after it is actually retired. The first RD returns the old dualoct value from the sense amp before it is overwritten. The second RD returns the new dualoct value that was just written.

Figure 15-1 Normal Retire (left) and Retire/Read Ordering (right)

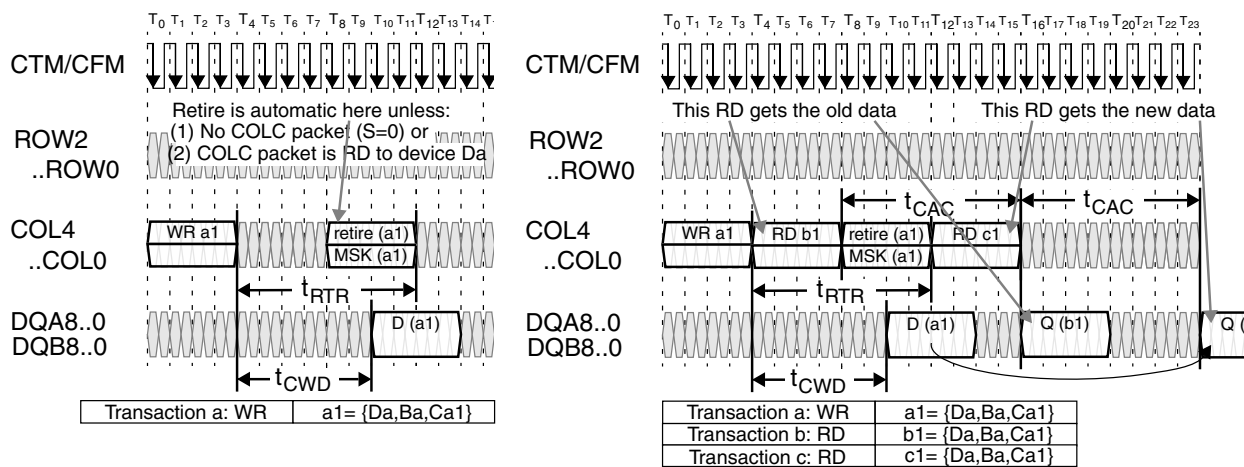

Figure 15-2 (left) shows the result of performing a RD command to the same device in the same COLC packet slot that would normally be used for the retire operation. The read may be to any bank and column address; all that matters is that it is to the same device as the WR command. The retire operation and  $MSK(a1)$  will be delayed by a time  $t_{PACKET}$  as a result. If the RD command used the same bank and column address as the WR command, the old data from the sense amp would be returned. If many RD commands to the same device were issued instead of the single one that is shown, then the retire operation would be held off an arbitrarily long time. However, once a RD to another device or a WR or NOCOP to any device is issued, the retire will take place. Figure 15-2 (right) illustrates a situation in which the controller wants to issue a WR-WR-RD COLC packet sequence, with all commands addressed to the same device, but addressed to any combination of banks and columns.

The RD will prevent a retire of the first WR from automatically happening. But the first dualoct  $D(a1)$  in the write

buffer will be overwritten by the second WR dualoct D(b1) if the RD command is issued in the third COLC packet. Therefore, it is required in this situation that the controller issue a NOCOP command in the third COLC packet, delaying the RD command by a time of  $t_{\text{PACKET}}$ . This situation is explicitly shown in Table 8-1 for the cases in which  $t_{\text{CDELAY}}$  is equal to  $t_{\text{RTR}}$ .

Figure 15-2 Retire Held Off by Read (left) and Controller Forces WWR Gap (right)

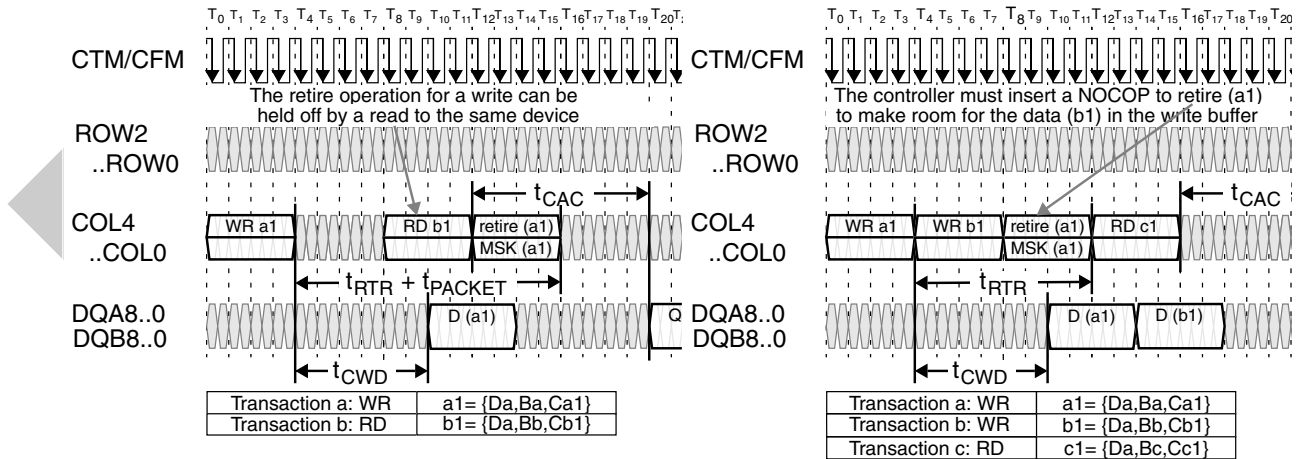
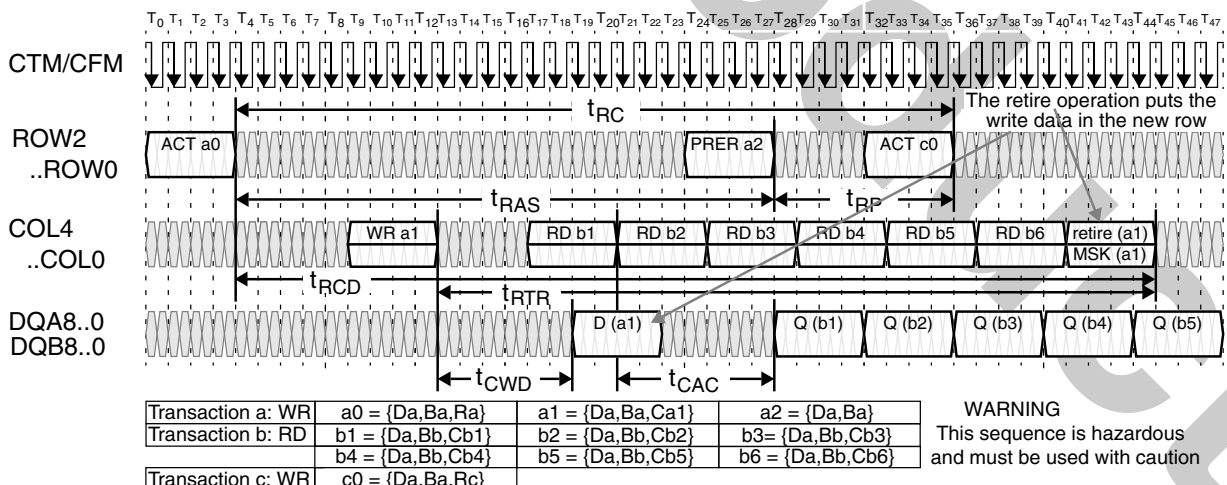

Figure 15-3 shows a possible result when a retire is held off for a long time (an extended version of Figure 15-2-left). After a WR command, a series of six RD commands are issued to the same device (but to any combination of bank and column addresses). In the meantime, the bank Ba to which the WR command was originally directed is precharged, and a different row Rc is activated. When the retire is automatically performed, it is made to this new row, since the write buffer only contains the bank and column address, not the row address. The controller can insure that this doesn't happen by never precharging a bank with an unretired write buffer. Note that in a system with more than one RDRAM device, there will never be more than two RDRAM devices with unretired write buffers. This is because a WR command issued to one device automatically retires the write buffers of all other devices written a time  $t_{\text{RTR}}$  before or earlier.

Figure 15-3 Retire Held Off by Reads to Same Device, Write Buffer Retired to New Row



16. Interleaved Write - Example

Figure 16-1 shows an example of an interleaved write transaction. Transactions similar to the one presented in Figure 14-1 are directed to non-adjacent banks of a single RDRAM device. This allows a new transaction to be issued once every  $t_{RR}$  interval rather than once every  $t_{RC}$  interval (four times more often). The DQ data pin efficiency is 100% with this sequence.

With two dualocts of data written per transaction, the COL, DQA, and DQB pins are fully utilized. Banks are precharged using the WRA autorecharge option rather than the PRER command in an ROWR packet on the ROW pins.

In this example, the first transaction is directed to device Da and bank Ba. The next three transactions are directed to the same device Da, but need to use different, non-adjacent banks Bb, Bc, Bd so there is no bank conflict. The fifth transaction could be redirected back to bank Ba without interference, since the first transaction would have completed by then ( $t_{RC}$  has elapsed). Each transaction may use any value of row address (Ra, Rb, ...) and column address (Ca1, Ca2, Cb1, Cb2, ...).

Figure 16-1 Interleaved Write Transaction with Two Dualoct Data Length

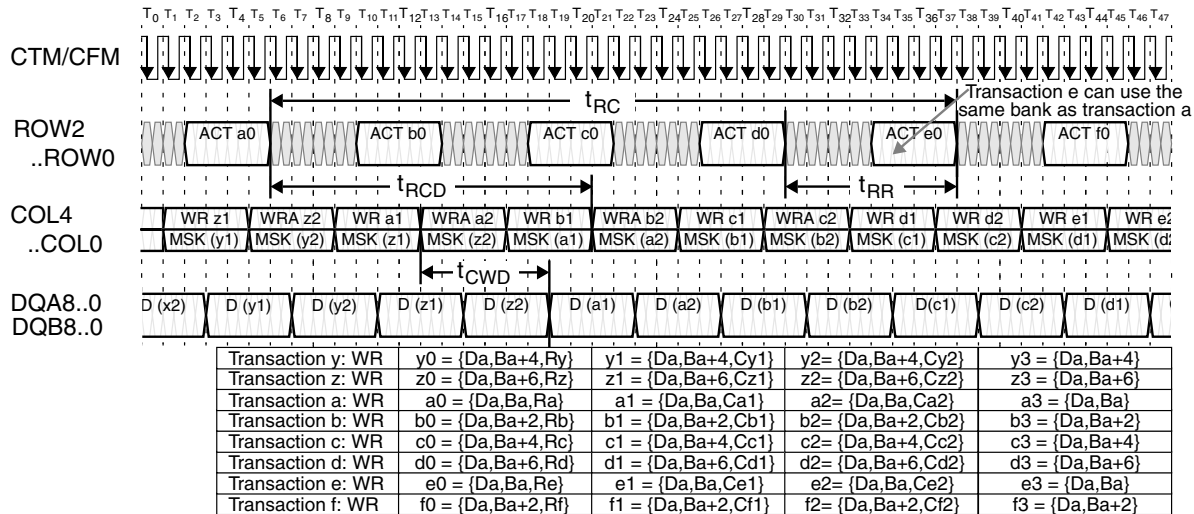

17. Interleaved Read - Example

Figure 17-1 shows an example of interleaved read transactions. Transactions similar to the one presented in Figure 13-1 are directed to non-adjacent banks of a single RDRAM device. The address sequence is identical to the one used in the previous write example. The DQ data pins efficiency is also 100%. The only difference with the write example (aside from the use of the RD command rather than the WR command) is the use of the PREX command in a COLX packet to precharge the banks rather than the RDA command. This is done because the PREX is available for a read transaction but is not available for a masked write transaction.

Figure 17-1 Interleaved Read Transaction with Two Dualoct Data Length

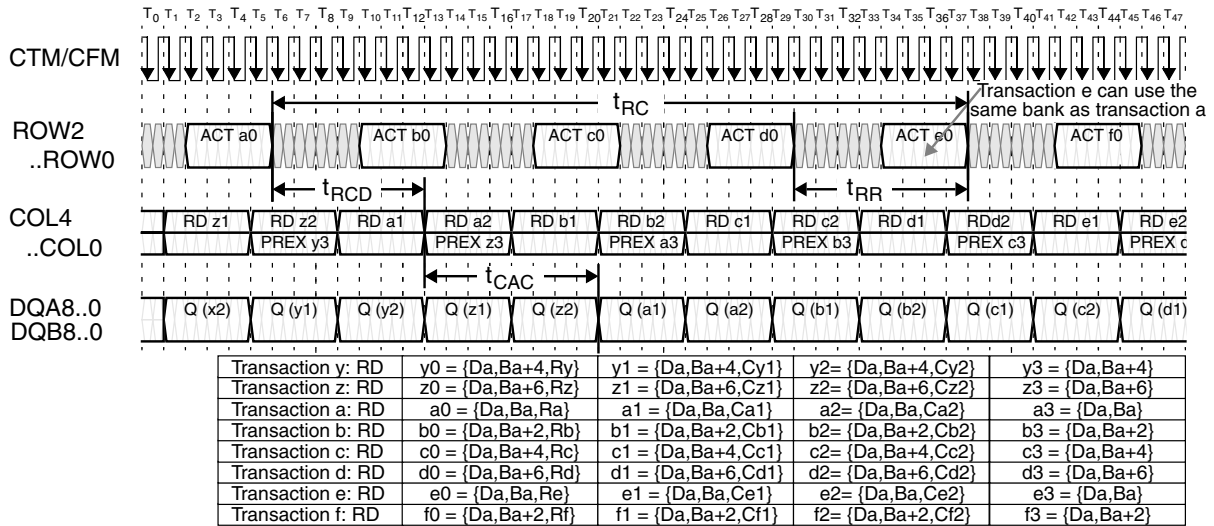

18. Interleaved RRWW - Example

Figure 18-1 shows a steady-state sequence of 2-dualoct RD/RD/WR/WR.. transactions directed to non-adjacent banks of a single RDRAM device. This is similar to the interleaved write and read examples in Figure 16-1 and Figure 17-1 except that bubble cycles need to be inserted by the controller at read/write boundaries. The DQ data pin efficiency for the example in Figure 18-1 is 32/42 or 76%. If there were more RDRAM devices on the Channel, the DQ pin efficiency would approach 32/34 or 94% for the two-dualoct RRWW sequence (this case is not shown).

In Figure 18-1, the first bubble type  $t_{CBUB1}$  is inserted by the controller between a RD and WR command on the COL pins. This bubble accounts for the round-trip propagation delay that is seen by read data, and is explained in detail in Figure 4-1. This bubble appears on the DQA and DQB pins as  $t_{DBUB1}$  between a write data dualoct D and read data dualoct Q. This bubble also appears on the ROW pins as  $t_{RBUB1}$ .

The second bubble type  $t_{CBUB2}$  is inserted (as a NOCOP command) by the controller between a WR and RD command on the COL pins when there is a WR-WR-RD sequence to the same device. This bubble enables write data to be retired from the write buffer without being lost, and is explained in detail in Figure 15-2. There would be no bubble if address c0 and address d0 were directed to different devices. This bubble appears on the DQA and DQB pins as  $t_{DBUB2}$  between a write data dualoct D and read data dualoct Q. This bubble also appears on the ROW pins as  $t_{RBUB2}$ .

Figure 18-1 Interleaved RRWW Sequence with Two Dualoct Data Length

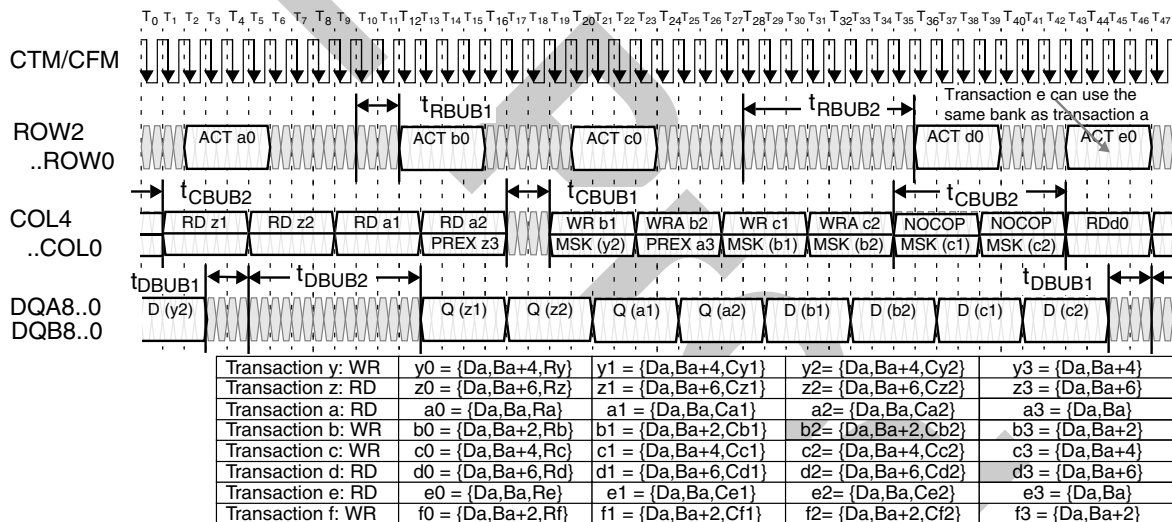

### 19. Control Register Transactions

The RDRAM device has two CMOS input pins SCK and CMD and two CMOS input/output pins SIO0 and SIO1. These provide serial access to a set of control registers in the device. These control registers provide configuration information to the controller during the initialization process. They also allow an application to select the appropriate operating mode of the device. SCK (serial clock) and CMD (command) are driven by the controller to all devices in parallel. SIO0 and SIO1 are connected (in a daisy chain fashion) from one device to the next. In normal operation, the data on SIO0 is repeated on SIO1, which connects to SIO0 of the next device (the data is repeated from SIO1 to SIO0 for a read data packet). The controller connects to SIO0 of the first device.

Write and read transactions are each composed of four packets, as shown in Figure 19-1 and Figure 19-2. Each packet consists of 16 bits, as summarized in Table 20-1 and Table 20-2. The packet bits are sampled on the falling edge of SCK. A transaction begins with a SRQ (Serial Request) packet. This packet is framed with a 11110000 pattern on the CMD input (note that the CMD bits are sampled on both the falling edge and the rising edge of SCK). The SRQ packet contains the SOP3..SOP0 (Serial Opcode) field, which selects the transaction type. The SDEV5..SDEV0 (Serial Device address) selects one of the 32 devices. If SBC (Serial Broadcast) is set, then all devices are selected. The SA (Serial Address) packet contains a 12 bit address for selecting a control register.

A write transaction has a SD (Serial Data) packet next. This contains 16 bits of data that is written into the selected control register. A SINT (Serial Interval) packet is last, providing some delay for any side-effects to take place. A read transaction has a SINT packet, then a SD packet. This provides delay for the selected device to access the control register. The SD read data packet travels in the opposite direction (towards the controller) from the other packet types. Because the device drives data on the falling SCK edge, the read data transmit window is offset  $t_{SCYCLE}/2$  relative to the other packet types. The SCK cycle time will accommodate the total propagation delay.

Figure 19-1 Serial Write (SWR) Transaction to Control Register

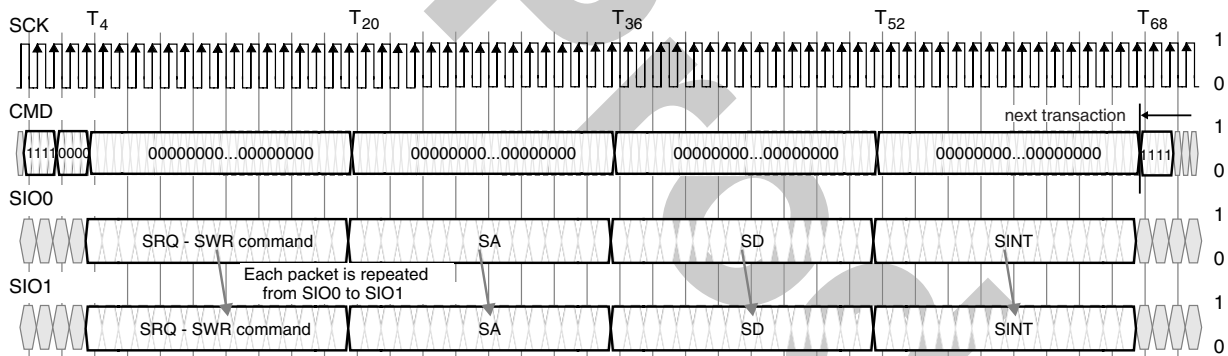
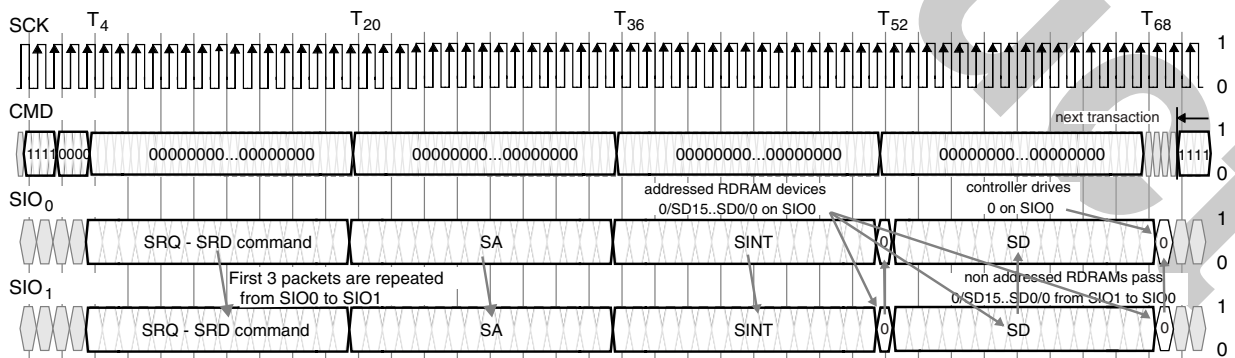

Figure 19-2 Serial Read (SRD) Transaction Control Register





20. Control Register Packets

Table 20-1 summarizes the formats of the four packet types for control register transactions. Table 20-2 summarizes the fields that are used within the packets.

Figure 20-1 shows the transaction format for the SETR, CLRR, and SETF commands. These transactions consist of a single SRQ packet, rather than four packets like the SWR and SRD commands. The same framing sequence on the CMD input is used, however.

Figure 20-1 SETR, CLRR, SETF Transaction

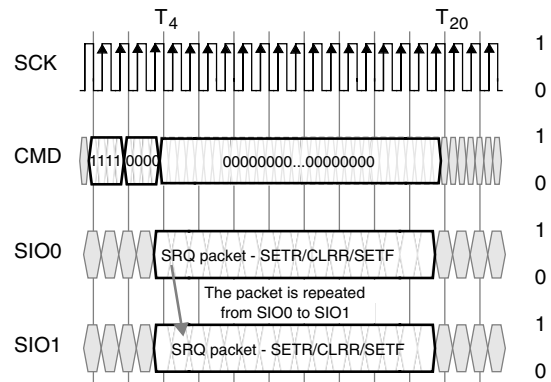

Table 20-1 Control Register Packet Formats

SCK Cycle	SIO0 or SIO1 for SRQ	SIO0 or SIO1 for SA	SIO0 or SIO1 for SINT	SIO0 or SIO1 for SD	SCK Cycle	SIO0 or SIO1 for SRQ	SIO0 or SIO1 for SA	SIO0 or SIO1 for SINT	SIO0 or SIO1 for SD
0	rsrv	rsrv	0	SD15	8	SOP1	SA7	0	SD7
1	rsrv	rsrv	0	SD14	9	SOP0	SA6	0	SD6
2	rsrv	rsrv	0	SD13	10	SBC	SA5	0	SD5
3	rsrv	rsrv	0	SD12	11	SDEV4	SA4	0	SD4
4	rsrv	SA11	0	SD11	12	SDEV3	SA3	0	SD3
5	SDEV5	SA10	0	SD10	13	SDEV2	SA2	0	SD2
6	SOP3	SA9	0	SD9	14	SDEV1	SA1	0	SD1
7	SOP2	SA8	0	SD8	15	SDEV0	SA0	0	SD0

Table 20-2 Field Description for Control Register Packets

Field	Description
rsrv	Reserved. Should be driven as "0" by controller.
SOP3..SOP0	0000 - SRD. Serial read of control register {SA11..SA0} of RDRAM device {SDEV5..SDEV0}. 0001 - SWR. Serial write of control register {SA11..SA0} of RDRAM device {SDEV5..SDEV0}. 0010 - SETR. Set Reset bit, all control registers assume their reset values. <sup>Note1</sup> 16 tSCYCLE delay until CLRR <sup>Note2</sup> command. 0100 - SETF. Set fast (normal) clock mode. 4 tSCYCLE delay until next command. 1011 - CLRR. Clear Reset bit, all control registers retain their reset values. <sup>Note1</sup> 4 tSCYCLE delay until next command. 1111 - NOP. No serial operation.
	0011, 0101 – 1010, 1100 – 1110 – RSRV. Reserved encodings.
SDEV5..SDEV0	Serial device. Compared to SDEVID5..SDEVID0 field of INIT control register field to select the RDRAM device to which the transaction is directed.
SBC	Serial broadcast. When set, RDRAM devices ignore {SDEV5..SDEV0} for RDRAM device selection.
SA11..SA0	Serial address. Selects which control register of the selected RDRAM device is read or written.
SD15..SD0	Serial data. The 16 bits of data written to or read from the selected control register of the selected RDRAM device.

**Notes** 1 The SETR and CLRR commands must always be applied in two successive transactions to RDRAM devices; i.e. they may not be used in isolation. This is called "SETR/CLRR Reset".

2 A minimum gap equal to the larger of (16•tSCYCLE, 2816•tCYCLE) must be inserted between a SETR/CLRR command pair.

## 21. Initialization

Figure 21-1 SIO Pin Reset Sequence

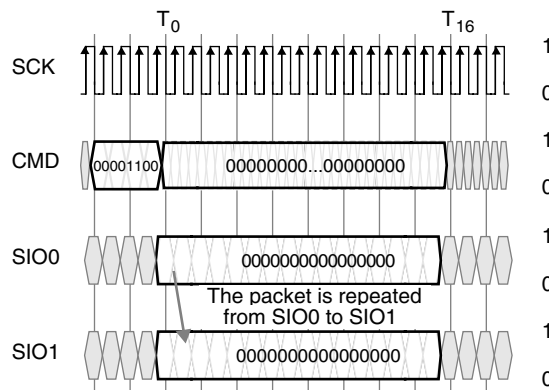

Initialization refers to the process that a controller must go through after power is applied to the system or the system is reset. The controller prepares the RDRAM sub-system for normal Channel operation by (primarily) using a sequence of control register transactions on the serial CMOS pins. The following steps outline the sequence seen by the various memory subsystem components (including the RDRAM components) during initialization. This sequence is available in the form of reference code. Contact Rambus Inc. for more information.

### 1.0 Start Clocks

This step calculates the proper clock frequencies for PClk (controller logic), SynCk (RAC block), RefCk (DRCG component), CTM (RDRAM component), and SCK (SIO block).

### 2.0 RAC Initialization

This step causes the INIT block to generate a sequence of pulses which resets the RAC, performs RAC maintenance operations, and measures timing intervals in order to ensure clock stability.

### 3.0 RDRAM device Initialization

This stage performs most of the steps needed to initialize the RDRAM devices. The rest are performed in stages 5.0, 6.0, and 7.0. All of the steps in 3.0 are carried out through the SIO block interface.

#### 3.1/3.2 SIO Reset

This reset operation is performed before any SIO control register read or write transactions. It clears six registers (TEST34, CCA, CCB, SKIP, TEST78, and TEST79) and places the INIT register into a special state (all bits cleared except SKP and SDEVID fields are set to ones). SCK must be held low until SIO Reset.

#### 3.3 Write TEST77 Register

The TEST77 register must be explicitly written with zeros before any other registers are read or written.

#### 3.4 Write TCYCLE Register

The TCYCLE register is written with the cycle time  $t_{\text{CYCLE}}$  of the CTM clock (for Channel and RDRAM devices) in units of 64ps. The  $t_{\text{CYCLE}}$  value is determined in stage 1.0.

#### 3.5 Write SDEVID Register

The SDEVID (serial device identification) register of each RDRAM device is written with a unique address value so that directed SIO read and write transactions can be performed. This address value increases from 0 to 31 according to the distance an RDRAM device is from the ASIC component on the SIO bus (the closest RDRAM device is address 0).

### 3.6 Write DEVID Register

The DEVID (device identification) register of the RDRAM device is written with a unique address value so that directed memory read and write transactions can be performed. This address value increases from 0 to 31. The DEVID value is not necessarily the same as the SDEVID value. RDRAM devices are sorted into regions of the same core configuration (number of bank, row, and column address bits and core type).

### 3.7 Write PDNX, PDNXA Registers

The PDNX and PDNXA registers are written with values that are used to measure the timing intervals connected with an exit from the PDN (powerdown) power state.

### 3.8 Write NAPX Register

The NAPX register is written with values that are used to measure the timing intervals connected with an exit from the NAP power state.

### 3.9 Write TPARM Register

The TPARM register is written with values which determine the time interval between a COL packet with a memory read command and the Q packet with the read data on the Channel. The values written set the RDRAM to the minimum value permitted for the system. This will be adjusted later in stage 6.0.

### 3.10 Write TCDLY1 Register

The TCDLY1 register is written with values which determine the time interval between a COL packet with a memory read command and the Q packet with the read data on the Channel. The values written set the RDRAM to the minimum value permitted for the system. This will be adjusted later in stage 6.0.

### 3.11 Write TFRM Register

The TFRM register is written with a value that is related to the  $t_{RCD}$  parameter for the system. The  $t_{RCD}$  parameter is the time interval between a ROW packet with an activate command and the COL packet with a read or write command.

### 3.12 SETR/CLRR

Each RDRAM device is given a SETR command and a CLRR command through the SIO block. This sequence performs a second reset operation on the RDRAM devices.

### 3.13 Write CCA and CCB Registers

These registers are written with a value halfway between their minimum and maximum values. This shortens the time needed for the RDRAM devices to reach their steady-state current control values in stage 5.0.

### 3.14 Powerdown Exit

The RDRAM devices are in the PDN power state at this point. A broadcast PDNExit command is performed by the SIO block to place the RDRAM devices in the RLX (relax) power state in which they are ready to receive ROW packets.

### 3.15 SETF

Each RDRAM device is given a SETF command through the SIO block. One of the operations performed by this step is to generate a value for the AS (autoskip) bit in the SKIP register and fix the RDRAM device to a particular read domain.

## 4.0 Controller Configuration

This stage initializes the controller block. Each step of this stage will set a field of the ConfigRMC[63:0] bus to the appropriate value. Other controller implementations will have similar initialization requirements, and this stage may be used as a guide.

### 4.1 Initial Read Data Offset

The ConfigRMC bus is written with a value which determines the time interval between a COL packet with a memory read command and the Q packet with the read data on the Channel. The value written sets RMC.d1 to the minimum value permitted for the system. This will be adjusted later in stage 6.0.

### 4.2 Configure Row/Column Timing

This step determines the values of the  $t_{RAS,MIN}$ ,  $t_{RP,MIN}$ ,  $t_{RC,MIN}$ ,  $t_{RCD,MIN}$ ,  $t_{RR,MIN}$ , and  $t_{PP,MIN}$  RDRAM timing parameters that are present in the system. The ConfigRMC bus is written with values that will be compatible with all RDRAM devices that are present.

### 4.3 Set Refresh Interval

This step determines the values of the  $t_{REF,MAX}$  RDRAM timing parameter that are present in the system. The ConfigRMC bus is written with a value that will be compatible with all RDRAM devices that are present.

### 4.4 Set Current Control Interval

This step determines the values of the  $t_{CTRL,MAX}$  RDRAM timing parameter that are present in the system. The ConfigRMC bus is written with a value that will be compatible with all RDRAM devices that are present.

### 4.5 Set Slew Rate Control Interval

This step determines the values of the  $t_{TEMP,MAX}$  RDRAM timing parameter that are present in the system. The ConfigRMC bus is written with a value that will be compatible with all RDRAM devices that are present.

### 4.6 Set Bank/Row/Col Address Bits

This step determines the number of RDRAM bank, row, and column address bits that are present in the system. It also determines the RDRAM core types (independent, doubled, or split) that are present. The ConfigRMC bus is written with a value that will be compatible with all RDRAM devices that are present.

## 5.0 RDRAM Current Control

This step causes the INIT block to generate a sequence of pulses which performs RDRAM maintenance operations.

## 6.0 RDRAM Core, Read Domain Initialization

This stage completes the RDRAM device initialization

### 6.1 RDRAM Core Initialization

A sequence of 192 memory refresh transactions is performed in order to place the cores of all RDRAM devices into the proper operating state.

### 6.2 RDRAM Read Domain Initialization

A memory write and memory read transaction is performed to each RDRAM device to determine which read domain each RDRAM device occupies. The programmed delay of each RDRAM device is then adjusted so the total RDRAM read delay (propagation delay plus programmed delay) is constant. The TPARM and TCDLY1 registers of each RDRAM device are rewritten with the appropriate read delay values. The ConfigRMC bus are also rewritten with an updated value.

### 7.0 Other RDRAM Register Fields

This stage rewrites the INIT register with the final values of the LSR, NSR, and PSR fields.

In essence, the controller must read all the read-only configuration registers of all RDRAM devices (or it must read the SPD device present on each RIMM), it must process this information, and then it must write all the read-write registers to place the RDRAM devices into the proper operating mode.

#### Initialization Note :

1. During the initialization process, it is necessary for the controller to perform 128 current control operations (3xCAL, 1xCAL/SAM) and one temperature calibrate operation (TCEN/TCAL) after reset or after powerdown (PDN) exit.
2. The behavior of EDR2518ABSE at initialization is as follows. It is distinguished by the "S28IECO" bit in the SPD.  
S28IECO=1: Upon powerup, the device enters PDN state. The serial operations SETR, CLRR, and SETF require a SDEVID match.  
See the document detailing the reference initialization procedure for more information on how to handle this in a system.
3. After the step of equalizing the total read delay of the RDRAM device has been completed (i.e. after the TCDLY0 and TCDLY1 fields have been written for the final time), a single final memory read transaction should be made to the RDRAM device in order to ensure that the output pipeline stages have been cleared.
4. The SETF command (in the serial SRQ packet) should only be issued once during the Initialization process, as should the SETR and CLRR commands.
5. The CLRR command (in the serial SRQ packet) leaves some of the contents of the memory core in an indeterminate state.

## 22. Control Register Summary

Table 22-1 summarizes the RDRAM control registers. Detail is provided for each control register in Figure 22-1. Read-only bits which are shaded gray are unused and return zero. Read-write bits which are shaded gray are reserved and should always be written with zero. The RIMM™ SPD Application Note (DL-0054) of Rambus Inc. describes additional read-only configuration registers which are present on Direct RIMMs.

The state of the register fields are potentially affected by the IO Reset operation or the SETR/CLRR operation. This is indicated in the text accompanying each register diagram.

**Table 22-1 Control Register Summary (1/2)**

SA11...SA0	Register	Field	read-write/ read-only	Description
021 <sub>16</sub>	INIT	SDEVID	read-write, 6 bits	Serial device ID. Device address for control register read/write.
		PSX	read-write, 1 bit	Power select exit. PDN/NAP exit with device addr on DQA5..0.
		SRP	read-write, 1 bit	SIO repeater. Used to initialize RDRAM devices.
		NSR	read-write, 1 bit	NAP self-refresh. Enables self-refresh in NAP mode.
		PSR	read-write, 1 bit	PDN self-refresh. Enables self-refresh in PDN mode.
		LSR	read-write, 1 bit	Low power self-refresh. Enables low power self-refresh.
		X	read-only, 1 bit	Output undefined
		DIS	read-write, 1 bit	RDRAM device disable.
		IDM	read-write, 1 bit	Interleaved Device Mode enable. IDM = 0 for version 3 device.
022 <sub>16</sub>	TEST34	TEST34	read-write, 16 bits	Test register.
023 <sub>16</sub>	CNFGA	REFBIT	read-only, 3 bits	Refresh bank bits. Used for multi-bank refresh.
		DBL	read-only, 1 bit	Double. Specifies doubled-bank architecture.
		MVER	read-only, 6 bits	Manufacturer version. Manufacturer identification number.
		PVER	read-only, 6 bits	Protocol version. Specifies version of Direct protocol supported.
024 <sub>16</sub>	CNFGB	BYT	read-only, 1 bit	Byte. Specifies an 8-bit or 9-bit byte size.
		DEVTYP	read-only, 3 bits	Device type. Device can be RDRAM device or some other device category.
		SPT	read-only, 1 bit	Split-core. Each core half is an individual dependent core.
		CORG	read-only, 6 bits	Core organization. Bank, row, column address field sizes.
		SVER	read-only, 6 bits	Stepping version. Mask version number.
040 <sub>16</sub>	DEVID	DEVID	read-write, 5 bits	Device ID. Device address for memory read/write.
041 <sub>16</sub>	REFB	REFB	read-write, 4 bits	Refresh bank. Next bank to be refreshed by self-refresh.
042 <sub>16</sub>	REFR	REFR	read-write, 9 bits	Refresh row. Next row to be refreshed by REFA, self-refresh.
043 <sub>16</sub>	CCA	CCA	read-write, 7 bits	Current control A. Controls I <sub>OL</sub> output current for DQA.
		ASYMA	read-write, 2 bits	Asymmetry control. Controls asymmetry of V <sub>OL</sub> /V <sub>OH</sub> swing for DQA.
044 <sub>16</sub>	CCB	CCB	read-write, 7 bits	Current control B. Controls I <sub>OL</sub> output current for DQB.
		ASYMB	read-write, 2 bits	Asymmetry control. Controls asymmetry of V <sub>OL</sub> /V <sub>OH</sub> swing for DQB.
045 <sub>16</sub>	NAPX	NAPXA	read-write, 5 bits	NAP exit. Specifies length of NAP exit phase A.
		NAPX	read-write, 5 bits	NAP exit. Specifies length of NAP exit phase A + phase B.
		DQS	read-write, 1 bit	DQ select. Selects CMD framing for NAP/PDN exit.
046 <sub>16</sub>	PDNXA	PDNXA	read-write, 13 bits	PDN exit. Specifies length of PDN exit phase A.

Table 22-1 Control Register Summary (2/2)

SA11..SA0	Register	Field	read-write/ read-only	Description
047 <sub>16</sub>	PDNX	PDNX	read-write, 13 bits	PDN exit. Specifies length of PDN exit phase A + phase B.
048 <sub>16</sub>	TPARM	TCAS	read-write, 2 bits	t <sub>CAS-C</sub> core parameter. Determines t <sub>OFFP</sub> datasheet parameter.
		TCLS	read-write, 2 bits	t <sub>CLS-C</sub> core parameter. Determines t <sub>CAC</sub> and t <sub>OFFP</sub> parameters.
		TCDLY0	read-write, 3 bits	t <sub>CDLY0-C</sub> core parameter. Programmable delay for read data.
049 <sub>16</sub>	TFRM	TFRM	read-write, 4 bits	t <sub>FRM-C</sub> core parameter. Determines ROW - COL packet framing interval.
04a <sub>16</sub>	TCDLY1	TCDLY1	read-write, 3 bits	t <sub>CDLY-1</sub> core parameter. Programmable delay for read data.
04c <sub>16</sub>	TCYCLE	TCYCLE	read-write, 14 bits	t <sub>CYCLE</sub> datasheet parameter. Specifies cycle time in 64ps units.
04b <sub>16</sub>	SKIP	AS	read-only, 1 bit	Autoskip value established by the SETF command.
		MSE	read-write, 1 bit	Manual skip enable. Allows the MS value to override the AS value.
		MS	read-write, 1 bit	Manual skip value.
04d <sub>16</sub> -	TEST77	TEST77	read-write, 16 bits	Test register. Write with zero after SIO reset.
04e <sub>16</sub> -	TEST78	TEST78	read-write, 16 bits	Test register. Do not read or write after SIO reset.
04f <sub>16</sub> -	TEST79	TEST79	read-write, 16 bits	Test register. Do not read or write after SIO reset.
055 <sub>16</sub>	TCPS	TCPS	read-write, 2bits	t <sub>CPS-C</sub> core parameter. Determines t <sub>OFFP</sub> parameters. (Version 3 only)
080 <sub>16</sub> -Off <sub>16</sub>	reserved	reserved	vendor-specific	Vendor-specific test registers. Do not read or write after SIO reset.

Figure 22-1 Control Registers (1/7)

<b>Control Register : INIT</b>										<b>Address : 021<sub>16</sub></b>					
15	14	13	12	11	10	9	8	7	6	5	4	3	2	1	0
IDM	SDEV5 VID5	DIS	X <sup>Note</sup>	0	LSR	PSR	NSR	SRP	PSX	0	SDEV4..0				

Read/write register.

Reset values are undefined except as affected by SIO Reset as noted below. SETR/CLRR Reset does not affect this register.

Note Read-only bit. Output undefined.

Field	Description	Reset value
IDM	Interleaved Device Mode enable. IDM = 0 for version 3 device.	
SDEV5..0	Serial Device Identification. Compared to SDEV5..0 serial address field of serial request packet for register read/write transactions. This determines which RDRAM device is selected for the register read or write operation.	3f <sub>16</sub>
DIS	RDRAM disable. DIS=1 causes RDRAM device to ignore NAP/PDN exit sequence, DIS=0 permit normal operation. This mechanism disables an RDRAM device.	0
LSR	Low Power Self-Refresh. This function is not supported. LSR value must be 0.	0
PSR	PDN Self-Refresh. PSR=1 enables self-refresh in PDN mode. PSR can't be set while in PDN mode.	0
NSR	NAP Self-Refresh. NSR=1 enables self-refresh in NAP mode. NSR can't be set while in NAP mode.	0
SRP	SIO Repeater. Controls value on SIO1; SIO1=SIO0 if SRP=1, SIO1=1 if SRP=0.	1
PSX	Power Exit Select. PDN and NAP are exited with (=0) or without (=1) a device address on the DQA5..0 pins. PDEV5 (on DQA5) selects broadcast (1) or directed (0) exit. For a directed exit, PDEV4..0 (on DQA4..0) is compared to DEVID4..0 to select a device.	

<b>Control Register : CNFGA</b>										<b>Address : 023<sub>16</sub></b>					
15	14	13	12	11	10	9	8	7	6	5	4	3	2	1	0
PVER5..0=000001						MVER5..0=mmmmmm						DBL1	REFBIT2..0=101		

Read only register.

Field	Description
PVER5..0	Protocol Version. Specifies the Direct Protocol version used by this device: 0 – Reserved 1 – Version 1 2 – Version 2 (version 1 + IDM) 3 – Version 3 (version 1 + programmable tcps)
MVER5..0	Manufacturer Version. Specifies the manufacturer identification number.
DBL	Doubled-Bank. DBL=1 means the device uses a doubled-bank architecture with adjacent-bank dependency. DBL=0 means no dependency.
REFBIT2..0	Refresh Bank Bits. Specifies the number of bank address bits used by REFA and REFP commands. Permits multi-bank refresh in future RDRAM devices.

**Caution** In RDRAM devices with protocol version 1 PVER[5:0] =000001, the range of the PDNX field (PDNX[2:0] in the PDNX register) may not be large enough to specify the location of the restricted interval in Figure 23-3. In this case, the effective ts<sub>4</sub> parameter must increase and no row or column packets may overlap the restricted interval. See Figure 23-3 and Timing conditions table.



Figure 22-1 Control Registers (2/7)

**Control Register : CNFGB**

**Address : 024<sub>16</sub>**

15	14	13	12	11	10	9	8	7	6	5	4	3	2	1	0
SVER5..0=ssssss						CORG4..0=01000					SPT0	DEVTYP2..0=000		BYTB	

Read only register.

Field	Description
SVER5..0	Stepping version. Specifies the mask version number of this device.
CORG4..0	Core organization. This field specifies the number of bank (5 bits), row (9 bits), and column (7 bits) address bits.
SPT	Split-core. SPT=1 means the core is split, SPT=0 means it is not.
DEVTYP2..0	Device type. DEVTYP=000 means that this device is an RDRAM device.
BYT	Byte width. B=1 means the device reads and writes 9-bit memory bytes. B=0 means 8 bits.

**Control Register : TEST34**

**Address : 022<sub>16</sub>**

15	14	13	12	11	10	9	8	7	6	5	4	3	2	1	0
0	0	0	0	0	0	0	0	0	0	0	0	0	0	0	0

Write only register.

Reset values of TEST34 is zero (from SIO Reset).

This register are used for testing purposes. It must not be read or written after SIO Reset.

**Control Register : DEVID**

**Address : 040<sub>16</sub>**

15	14	13	12	11	10	9	8	7	6	5	4	3	2	1	0
0	0	0	0	0	0	0	0	0	0	0	DEVID4..0				

Read/write register.

Reset value is undefined.

Field	Description
DEVID4..0	Device Identification register. DEVID4..DEVID0 is compared to DR4..DR0, DC4..DC0, and DX4..DX0 fields for all memory read or write transactions. This determines which RDRAM device is selected for the memory read or write transaction.

Figure 22-1 Control Registers (3/7)

**Control Register : REFB**

**Address : 041<sub>16</sub>**

15	14	13	12	11	10	9	8	7	6	5	4	3	2	1	0
0	0	0	0	0	0	0	0	0	0	0	REFB4..0				

Read/write register.

Field	Description	Reset value
REFB4..0	Reset value is zero (from SETR/CLRR). Refresh Bank Register. REFB4..REFB0 is the bank that will be refreshed next during self-refresh. REFB4..0 is incremented after each self-refresh activate and precharge operation pair.	0

**Control Register : REFR**

**Address : 042<sub>16</sub>**

15	14	13	12	11	10	9	8	7	6	5	4	3	2	1	0
0	0	0	0	0	0	0	REFR8..0								

Read/write register.

Field	Description	Reset value
REFR8..0	Reset value is zero (from SETR/CLRR). Refresh Row register. REFR8..REFR0 is the row that will be refreshed next by the REFA command or by self-refresh. REFR8..0 is incremented when BR4..0=11111 for the REFA command. REFR8..0 is incremented when REFB4..0=11111 for self-refresh.	0

**Control Register : CCA**

**Address : 043<sub>16</sub>**

15	14	13	12	11	10	9	8	7	6	5	4	3	2	1	0
0	0	0	0	0	0	0	0	ASYM A0	CCA6..0						

Read/write register.

Reset value is zero (from SETR/CLRR or SIO Reset).

Field	Description	Reset value
ASYMA0	ASYMA0 control the asymmetry of the Vol/Voh voltage swing about the VREF reference voltage for the DQA8..0 pins.	0
CCA6..0	Current Control A. Controls the IoL output current for the DQA8..DQA0 pins.	

**Control Register : CCB**

**Address : 044<sub>16</sub>**

15	14	13	12	11	10	9	8	7	6	5	4	3	2	1	0
0	0	0	0	0	0	0	0	ASYM B0	CCB6..0						

Read/write register.

Reset value is zero (from SETR/CLRR or SIO Reset).

Field	Description	Reset value
ASYMB0	ASYMB0 control the asymmetry of the Vol/Voh voltage swing about the VREF reference voltage for the DQB8..0 pins.	0
CCB6..0	Current Control B. Controls the IoL output current for the DQB8..DQB0 pins.	

Figure 22-1 Control Registers (4/7)

**Control Register : NAPX**

**Address : 045<sub>16</sub>**

15	14	13	12	11	10	9	8	7	6	5	4	3	2	1	0
0	0	0	0	0	DQS	NAPX4..0					NAPXA4..0				

Read/write register.

Reset value is 0525<sub>16</sub> (SIOReset).

Note t<sub>SCYCLE</sub> is t<sub>CYCLE1</sub> (SCK cycle time).

Field	Description
DQS	DQ Select. This field specifies the number of SCK cycles ( $0 \geq 0.5$ cycles, $1 \geq 1.5$ cycles) between the CMD pin framing sequence and the device selection on DQ5..0. see Figure 23-4. This field must be written with a "1" for this RDRAM.
NAPX4..0	Nap Exit Phase A plus B. This field specifies the number of SCK cycles during the first plus second phases for exiting NAP mode. It must satisfy: $NAPX \cdot t_{SCYCLE} \geq NAPXA \cdot t_{SCYCLE} + t_{NAPXB,MAX}$ Do not set this field to zero.
NAPXA4..0	Nap Exit Phase A. This field specifies the number of SCK cycles during the first phase for exiting NAP mode. It must satisfy: $NAPXA \cdot t_{SCYCLE} \geq t_{NAPXA,MAX}$ Do not set this field to zero.

**Control Register : PDNXA**

**Address : 046<sub>16</sub>**

15	14	13	12	11	10	9	8	7	6	5	4	3	2	1	0
0	0	0	PDNXA12..0												

Read/write register.

Reset value is 0008<sub>16</sub> (SIOReset).

Field	Description
PDNXA4..0	PDN Exit Phase A. This field specifies the number of (64•SCK cycle) units during the first phase for exiting PDN mode. It must satisfy: $PDNXA \cdot 64 \cdot t_{SCYCLE} \geq t_{PDNXA,MAX}$ Do not set this field to zero. Note – only PDNXA4..0 are implemented. Note – t <sub>SCYCLE</sub> is t <sub>CYCLE1</sub> (SCK cycle time).

**Control Register : PDNX**

**Address : 047<sub>16</sub>**

15	14	13	12	11	10	9	8	7	6	5	4	3	2	1	0
0	0	0	PDNX12..0												

Read/write register.

Reset value is 0007<sub>16</sub> (SIOReset).

Field	Description
PDNX2..0	PDN Exit Phase A puls B. This field specifies the number of (256•SCK cycle) units during the first plus second phases for exiting PDN mode. It should satisfy: $PDNX \cdot 256 \cdot t_{SCYCLE} \geq PDNXA \cdot 64 \cdot t_{SCYCLE} + t_{PDNXB,MAX}$ If this equation can't be satisfied, then the maximum PDNX value should be written, and the ts4 / th4 timing window will be modified (see Figure 23-4). Do not set this field to zero. Note – only PDNX2..0 are implemented. Note – t <sub>SCYCLE</sub> is t <sub>CYCLE1</sub> (SCK cycle time).

Figure 22-1 Control Registers (5/7)

**Control Register : TPARM**

**Address : 048<sub>16</sub>**

15	14	13	12	11	10	9	8	7	6	5	4	3	2	1	0
0	0	0	0	0	0	0	0	0	TCDLY0		TCLS		TCAL		

Read/write register.  
Reset value is undefined.

Field	Description
TCDLY0	Specifies the tCDLY0-C core parameter in tCYCLE units. This adds a programmable delay to Q (read data) packets, permitting round trip read delay to all device to be equalized. This field may be written with the values "011" (3•tCYCLE) through "101" (5•tCYCLE).
TCLS1..0	Specifies the tCLS-C core parameter in tCYCLE units. Should be "10" (2•tCYCLE).
TCAS1..0	Specifies the tCAS-C core parameter in tCYCLE units. This should be "10" (2•tCYCLE).

The equations relating the core parameters to the datasheet parameters follow:

$$tCAS-C = 2 \bullet tCYCLE$$

$$tCLS-C = 2 \bullet tCYCLE$$

$$tCPS-C = 1 \bullet tCYCLE$$

$$tOFFP = tCPS-C + tCAS-C + tCLS-C - 1 \bullet tCYCLE$$

$$= 4 \bullet tCYCLE$$

$$tRCD = tRCD-C + 1 \bullet tCYCLE - tCLS-C$$

$$= tRCD-C - 1 \bullet tCYCLE$$

$$tCAC = 3 \bullet tCYCLE + tCLS-C + tCDLY0-C + tCDLY1-C \text{ (see table below programming ranges)}$$

TCDLY0	tCDLY0-C	TCDLY1	tCDLY1-C	tCAC@tCYCLE=2.50 ns	tCAC@tCYCLE=1.875 ns
011	3•tCYCLE	000	0•tCYCLE	8•tCYCLE	8•tCYCLE <sup>Note</sup>
011	3•tCYCLE	001	1•tCYCLE	9•tCYCLE	not allowed
100	4•tCYCLE	000	0•tCYCLE	9•tCYCLE	9•tCYCLE
011	3•tCYCLE	010	2•tCYCLE	10•tCYCLE	not allowed
100	4•tCYCLE	001	1•tCYCLE	10•tCYCLE	10•tCYCLE
100	4•tCYCLE	010	2•tCYCLE	11•tCYCLE	11•tCYCLE
101	5•tCYCLE	010	2•tCYCLE	12•tCYCLE	12•tCYCLE

Note Used only for device bins that support tCAC = 8

**Control Register : TFRM**

**Address : 049<sub>16</sub>**

15	14	13	12	11	10	9	8	7	6	5	4	3	2	1	0
0	0	0	0	0	0	0	0	0	0	0	0	TFRM3..0			

Read/write register.  
Reset value is undefined.

Field	Description
TFRM3..0	Specifies the position of the framing point in tCYCLE units. This value must be greater than or equal to the tFRM,MIN parameter. This is the minimum offset between a ROW packet (which places a device at ATTN) and the first COL packet (directed to that device) which must be framed. This field may be written with the value "0111" (7•tCYCLE) through "1010" (10•tCYCLE). TFRM is usually set to the value which matches the largest tRCD,MIN parameter (modulo 4•tCYCLE) that is present in an RDRAM device in the memory system. Thus, if an RDRAM device with tRCD,MIN=11•tCYCLE were present, then TFRM would be programmed to 7•tCYCLE.

Figure 22-1 Control Registers (6/7)

**Control Register : TCDLY1**

**Address : 04a16**

15	14	13	12	11	10	9	8	7	6	5	4	3	2	1	0
0	0	0	0	0	0	0	0	0	0	0	0	0	TCDLY1		

Read/write register.  
Reset value is undefined.

Field	Description
TCDLY1	Specifies the value of the tcdly1-c core parameter in tcycle units. This adds a programmable delay to Q (read data) packets, permitting round trip read to delay all devices to be equalized. This field may be written with the values "000" (0•tcycle) through "010" (2•tcycle). Refer to TPARM Register for more details.

**Control Register : SKIP**

**Address : 04b16**

15	14	13	12	11	10	9	8	7	6	5	4	3	2	1	0
0	0	0	AS	MSE	MS	0	0	0	0	0	0	0	0	0	0

Read/write register (except AS field).  
Reset value is zero (SIO Reset).

Field	Description
MS	Manual skip (MS=1 corresponds to the early Q(a1) packet and AS=0 to the Q(a1) packet one tcycle later for the four uncertain cases in Figure34-1.).
MSE	Manual skip enable (0=auto, 1=manual).
AS	Autoskip. Read-only value determined by autoskip circuit and stored when SETF serial command is received by RDRAM during initialization. In Figure34-1, AS=1 corresponds to the early Q(a1) packet and AS=0 to the Q(a1) packet one tcycle later for the four uncertain cases.

**Control Register : TCYCLE**

**Address : 04c16**

15	14	13	12	11	10	9	8	7	6	5	4	3	2	1	0
0	0	TCYCLE13..0													

Read/write register.  
Reset value is undefined.

Field	Description
TCYCLE13..0	Specifies the value of the tcycle datasheet parameter in 64ps units. For the tcycle.min of 2.50 ns (2500ps), this field should be written with the value "0002716" (39•64ps).

Figure 22-1 Control Registers (7/7)

<b>Control Register : TEST77</b>
<b>Control Register : TEST78</b>
<b>Control Register : TEST79</b>

<b>Address : 04d16</b>
<b>Address : 04e16</b>
<b>Address : 04f16</b>

15	14	13	12	11	10	9	8	7	6	5	4	3	2	1	0
0	0	0	0	0	0	0	0	0	0	0	0	0	0	0	0

Read/write register.

These registers must only be used for testing purposes.

Field	Description	Reset value
TEST77	It must be written with zero after SIO reset.	—
TEST78	Reset value is zero (SIO Reset). Do not read or written after SIO reset.	0
TEST79	Reset value is zero (SIO Reset). Do not read or written after SIO reset.	0

<b>Control Register : TCPS</b>
--------------------------------

<b>Address : 05516</b>
------------------------

15	14	13	12	11	10	9	8	7	6	5	4	3	2	1	0
0	0	0	0	0	0	0	0	0	0	0	0	0	0	0	TCPS

Read/write register

Reset value is 0001<sub>16</sub> (SETR/CLRR).

Field	Description
TCPS	Specifies the value pf the tcps-c core parameter in tcycle units. This adds a programmable delay to toffp. This field may be written with the values "01" (1•tcycle) through "11" (3•tcycle). Refer to the Figure 22-1 (5/7).

Note This register is implemented (as stated above) in a version 3 device and unimplemented in a version 1, 2 device.

## 23. Power State Management

Table 23-1 summarizes the power states available to an RDRAM device. In general, the lowest power states have the longest operational latencies. For example, the relative power levels of PDN state and STBY state have a ratio of about 1:110, and the relative access latencies to get read data have a ratio of about 250:1.

PDN state is the lowest power state available. The information in the RDRAM core is usually maintained with self-refresh; an internal timer automatically refreshes all rows of all banks. PDN has a relatively long exit latency because the TCLK/RCLK block must resynchronize itself to the external clock signal.

NAP state is another low-power state in which either self-refresh or REFA-refresh are used to maintain the core. See **24. Refresh** for a description of the two refresh mechanisms. NAP has a shorter exit latency than PDN because the TCLK/RCLK block maintains its synchronization state relative to the external clock signal at the time of NAP entry. This imposes a limit ( $t_{NLIMIT}$ ) on how long an RDRAM device may remain in NAP state before briefly returning to STBY or ATTN to update this synchronization state.

**Table 23-1 Power State Summary**

Power State	Description	Blocks consuming power	Power state	Description	Blocks consuming power
PDN	Powerdown state.	Self-refresh	NAP	Nap state. Similar to PDN except lower wake-up latency.	Self-refresh or REFA-refresh TCLK/RCLK-Nap
STBY	Standby state. Ready for ROW packets.	REFA-refresh TCLK/RCLK ROW demux receiver	ATTN	Attention state. Ready for ROW and COL packets.	REFA-refresh TCLK/RCLK ROW demux receiver COL demux receiver
ATTNR	Attention read state. Ready for ROW and COL packets. Sending Q (read data) packets.	REFA-refresh TCLK/RCLK ROW demux receiver COL demux receiver DQ mux transmitter Core power	ATTNW	Attention write state. Ready for ROW and COL packets. Ready for D (write data) packets.	REFA-refresh TCLK/RCLK ROW demux receiver COL demux receiver DQ demux receiver Core power

Figure 23-1 summarizes the transition conditions needed for moving between the various power states.

Figure 23-1 Power State Transition Diagram

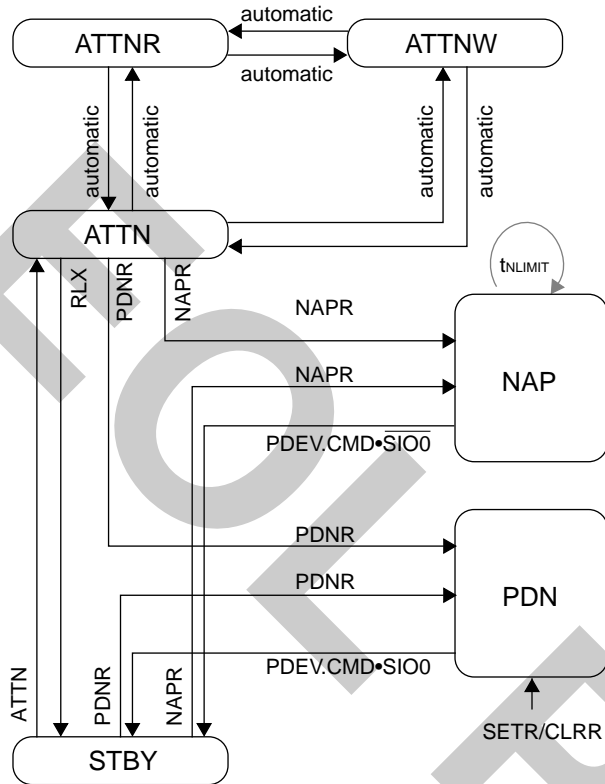

Notation:  
 SETR/CLRR - SETR/CLRR Reset sequence in SRQ packet  
 PDNR - PDNR command in ROWR packet  
 NAPR - NAPR command in ROWR packet  
 RLXR - RLX command in ROWR packet  
 RLX - RLX command in ROWR, COLC, COLX packets  
 SIO0 - SIO0 input value  
 PDEV.CMD - (PDEV=DEVID)•(CMD=01)  
 ATTN - ROWA packet(non-broadcast) or ROWR packet (non-broadcast) with ATTN command

At initialization, the SETR/CLRR Reset sequence will put the RDRAM device into PDN state. The PDN exit sequence involves an optional PDEV specification and bits on the CMD and SIO<sub>IN</sub> pins.

Once the RDRAM device is in STBY, it will move to the ATTN/ATTNR/ATTNW states when it receives a non-broadcast ROWA packet or non-broadcast ROWR packet with the ATTN command. The RDRAM device returns to STBY from these three states when it receives a RLX command. Alternatively, it may enter NAP or PDN state from ATTN or STBY states with a NAPR or PDNR command in an ROWR packet. The PDN or NAP exit sequence involves an optional PDEV specification and bits on the CMD and SIO<sub>IN</sub> pins. The RDRAM device returns to the STBY state it was originally in when it first entered NAP or PDN.

An RDRAM device may only remain in NAP state for a time  $t_{NLIMIT}$ . It must periodically return to ATTN or STBY.

The NAPRC command causes a napdown operation if the RDRAM device's NCBIT is set. The NCBIT is not directly visible. It is undefined on reset. It is set by a NAPR command to the RDRAM device, and it is cleared by an ACT command to the RDRAM device. It permits a controller to manage a set of RDRAM devices in a mixture of power states.

STBY state is the normal idle state of the RDRAM device. In this state all banks and sense amps have usually been left precharged and ROWA and ROWR packets on the ROW pins are being monitored. When a non-broadcast ROWA packet or non-broadcast ROWR packet(with the ATTN command) packet addressed to the RDRAM device is seen, the RDRAM device enters ATTN state (see the right side of Figure 23-2). This requires a time  $t_{SA}$  during which the RDRAM device activates the specified row of the specified bank. A time  $TFRM \cdot t_{CYCLE}$  after the ROW packet, the RDRAM device will be able to frame COL packets (TFRM is a control register field – see Figure 22-1(5/7) “**TFRM Register**”). Once in ATTN state, the RDRAM device will automatically transition to the ATTNW and ATTNR states as it receives WR and RD commands.



Once the RDRAM device is in ATTN, ATTNW, or ATTNR states, it will remain there until it is explicitly returned to the STBY state with a RLX command. A RLX command may be given in an ROWR, COLC, or COLX packet (see the left side of Figure 23-2). It is usually given after all banks of the RDRAM device have been precharged; if other banks are still activated, then the RLX command would probably not be given.

If a broadcast ROWA packet or ROWR packet (with the ATTN command) is received, the RDRAM device's power state doesn't change. If a broadcast ROWR packet with RLXR command is received, the RDRAM device goes to STBY.

Figure 23-2 STBY Entry (left) and STBY Exit (right)

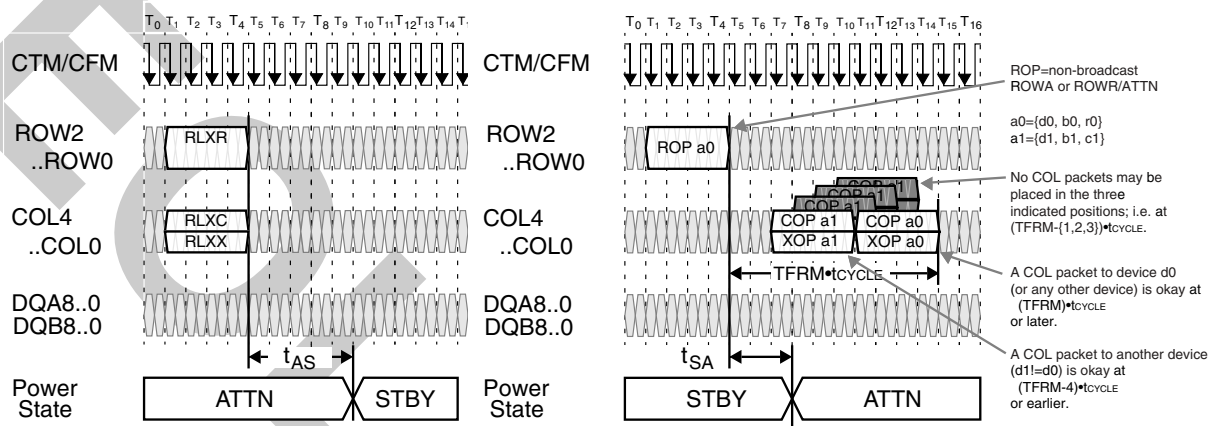
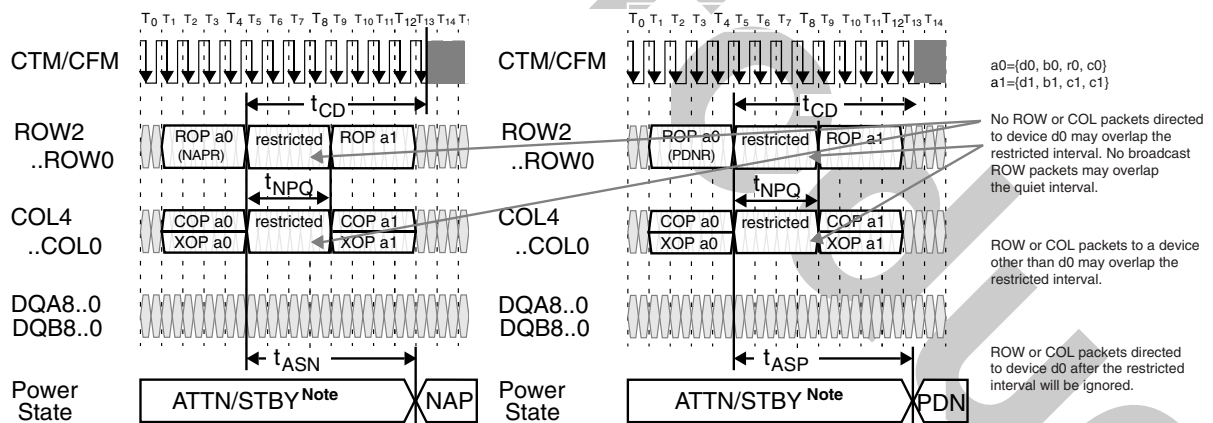

Figure 23-3 shows the NAP entry sequence (left). NAP state is entered by sending a NAPR command in a ROW packet. A time  $t_{ASN}$  is required to enter NAP state (this specification is provided for power calculation purposes). The clock on CTM/CFM must remain stable for a time  $t_{CD}$  after the NAPR command.

Figure 23-3 NAP Entry (left) and PDN Entry (right)



Note The (eventual) NAP/PDN exit will be to the same ATTN/STBY state the RDRAM was in prior to NAP/PDN entry

The RDRAM device may be in ATTN or STBY state when the NAPR command is issued. When NAP state is exited, the RDRAM device will return to the STBY. After a NAP exit, the RDRAM device may consume power as if it is in ATTN state until a RLX command is received.

Figure 23-3 also shows the PDN entry sequence (right). PDN state is entered by sending a PDNR command in a ROW packet. A time  $t_{ASP}$  is required to enter PDN state (this specification is provided for power calculation purposes). The clock on CTM/CFM must remain stable for a time  $t_{CD}$  after the PDNR command.

The RDRAM device may be in ATTN or STBY state when the PDNR command is issued. When PDN state is exited, the RDRAM device will return to the STBY. After a PDX exit, the RDRAM device may consume power as if it is in ATTN state until a RLX command is received. Also, the current- and slew-rate-control levels are re-established.

The RDRAM device's write buffer must be retired with the appropriate COP command before NAP or PDN are entered. Also, all the RDRAM device's banks must be precharged before NAP or PDN are entered. The exception to this is if NAP is entered with the NSR bit of the INIT register cleared (disabling self-refresh in NAP). The commands for relaxing, retiring, and precharging may be given to the RDRAM device as late as the ROPa0, COPa0, and XOPa0 packets in Figure 23-3. No broadcast packets nor packets directed to the RDRAM device entering NAP or PDN may overlay the quiet window. This window extends for a time  $t_{NPQ}$  after the packet with the NAPR or PDNR command.

Figure 23-4 shows the NAP and PDN exit sequences. These sequences are virtually identical; the minor differences will be highlighted in the following description.

Before NAP or PDN exit, the CTM/CFM clock must be stable for a time  $t_{CE}$ . Then, on a falling and rising edge of SCK, if there is a "01" on the CMD input, NAP or PDN state will be exited. Also, on the falling SCK edge the SIO0 input must be at a 0 for NAP exit and 1 for PDN exit.

If the PSX bit of the INIT register is 0, then a device PDEV5..0 is specified for NAP or PDN exit on the DQA5..0 pins. This value is driven on the rising SCK edge 0.5 or 1.5 SCK cycles after the original falling edge, depending upon the value of the DQS bit of the NAPX register. If the PSX bit of the INIT register is 1, then the RDRAM device ignores the PDEV5..0 address packet and exits NAP or PDN when the wake-up sequence is presented on the CMD wire. The ROW and COL pins must be quiet at a time  $t_{S4} / t_{H4}$  around the indicated falling SCK edge (timed with the PDNX or NAPX register fields). After that, ROW and COL packets may be directed to the RDRAM device which is now in STBY state.

Figure 23-5 shows the constraints for entering and exiting NAP and PDN states. On the left side, an RDRAM device exits NAP state at the end of cycle  $T_3$ . This RDRAM device may not re-enter NAP or PDN state for an interval of  $t_{NU0}$ . The RDRAM device enters NAP state at the end of cycle  $T_{13}$ . This RDRAM device may not re-exit NAP state for an interval of  $t_{NU1}$ . The equations for these two parameters depend upon a number of factors, and are shown at the bottom of the figure. NAPX is the value in the NAPX field in the NAPX register.

On the right side of Figure 23-4, an RDRAM device exits PDN state at the end of cycle  $T_3$ . The RDRAM device may not re-enter PDN or NAP state for an interval of  $t_{PU0}$ . The RDRAM device enters PDN state at the end of cycle  $T_{13}$  and may not re-exit PDN state for an interval of  $t_{PU1}$ . The equations for these two parameters depend upon a number of factors, and are shown at the bottom of the figure. PDNX is the value in the PDNX field in the PDNX register.

Figure 23-4 NAP and PDN Exit

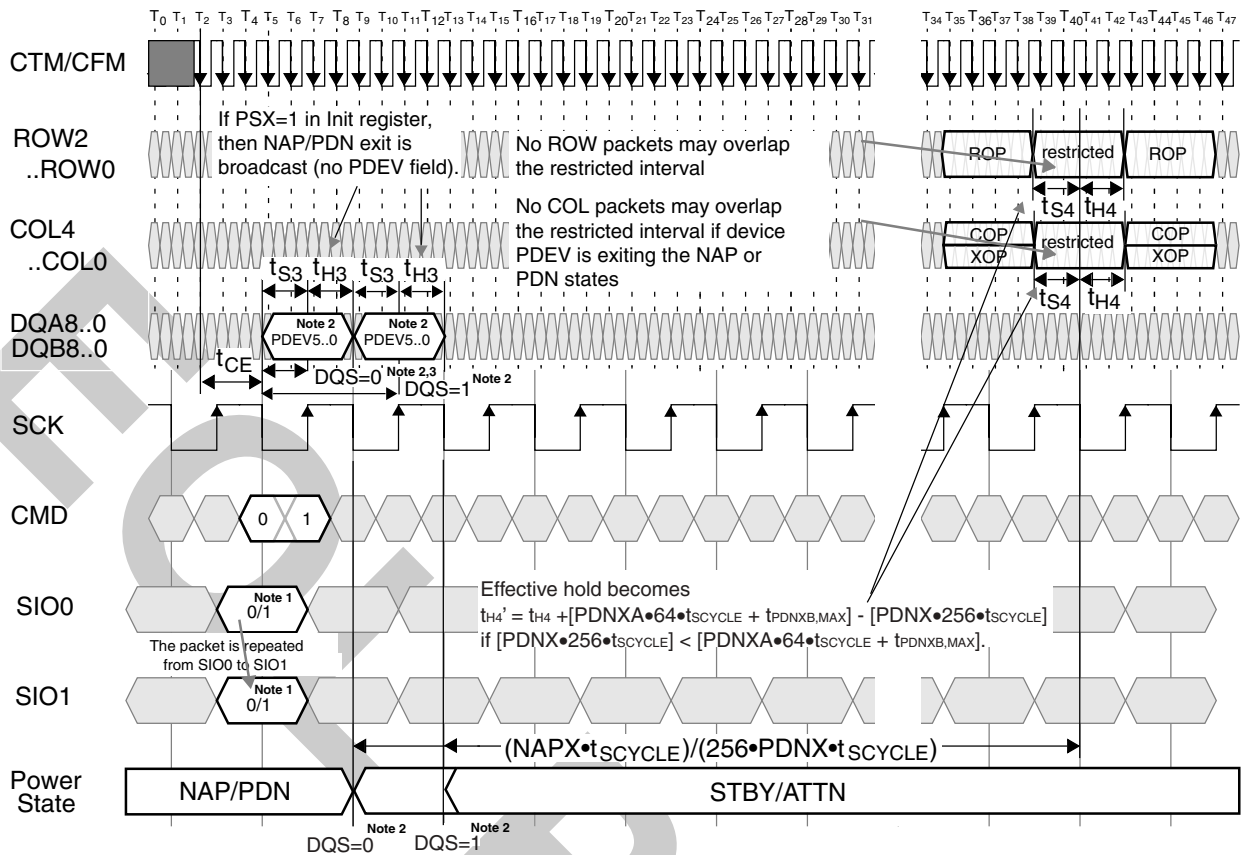

- Notes 1.** Use 0 for NAP exit, 1 for PDN exit  
**2.** Device selection timing slot is selected by DQS field of NAPX register. The PSX field determines the start of NAP/PDN exit.  
**3.** The DQS field must be written with "1" for this RDRAM.

Figure 23-5 NAP Entry/Exit Windows (left) and PDN Entry/Exit Windows (right)

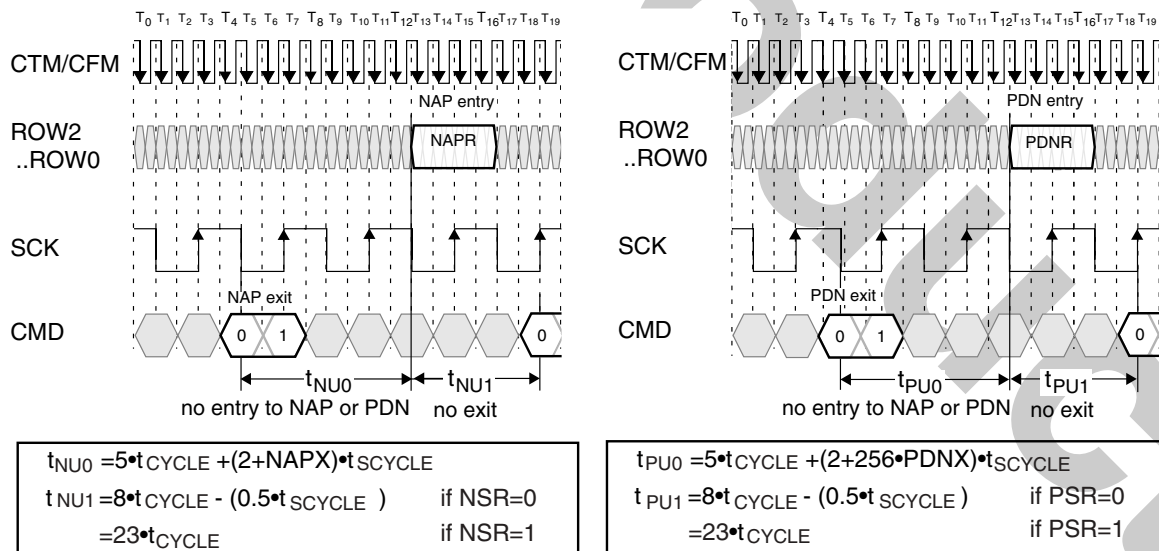

## 24. Refresh

RDRAM devices, like any other DRAM technology, use volatile storage cells which must be periodically refreshed. This is accomplished with the REFA command. Figure 24-1 shows an example of this.

The REFA command in the transaction is typically a broadcast command (DR4T and DR4F are both set in the ROWR packet), so that in all devices bank number Ba is activated with row number REFR, where REFR is a control register in the RDRAM device. When the command is broadcast and ATTN is set, the power state of the RDRAM devices (ATTN or STBY) will remain unchanged. The controller increments the bank address Ba for the next REFA command. When Ba is equal to its maximum value, the RDRAM device automatically increments REFR for the next REFA command.

On average, these REFA commands are sent once every  $t_{REF} / 2^{BBIT+RBIT}$  (where BBIT are the number of bank address bits and RBIT are the number of row address bits) so that each row of each bank is refreshed once every  $t_{REF}$  interval.

The REFA command is equivalent to an ACT command, in terms of the way that it interacts with other packets (see Table 6-1). In the example, an ACT command is sent after  $t_{RR}$  to address b0, a different (non-adjacent) bank than the REFA command.

A second ACT command can be sent after a time  $t_{RC}$  to address c0, the same bank (or an adjacent bank) as the REFA command.

Note that a broadcast REFP command is issued a time  $t_{RAS}$  after the initial REFA command in order to precharge the refreshed bank in all RDRAM devices. After a bank is given a REFA command, no other core operations (activate or precharge) should be issued to it until it receives a REFP.

It is also possible to interleave refresh transactions (not shown). In the figure, the ACT b0 command would be replaced by a REFA b0 command. The b0 address would be broadcast to all devices, and would be {Broadcast, Ba+2, REFR}. Note that the bank address should skip by two to avoid adjacent bank interference. A possible bank incrementing pattern would be: {12, 10, 5, 3, 0, 14, 9, 7, 4, 2, 13, 11, 8, 6, 1, 15, 28, 26, 21, 19, 16, 30, 25, 23, 20, 18, 29, 27, 24, 22, 17, 31}. Every time bank 31 is reached, a REFA command would automatically increment the REFR register.

A second refresh mechanism is available for use in PDN and NAP power states. This mechanism is called self-refresh mode. When the PDN power state is entered, or when NAP power state is entered with the NSR control register bit set, then self-refresh is automatically started for the RDRAM device.

Self-refresh uses an internal time base reference in the RDRAM device. This causes an activate and precharge to be carried out once in every  $t_{REF} / 2^{BBIT+RBIT}$  interval. The REFB and REFR control registers are used to keep track of the bank and row being refreshed.

Before a controller places an RDRAM device into self-refresh mode, it should perform REFA/REFP refreshes until the bank address is equal to the last value (this will be 31 for all sequence). This ensures that no rows are skipped. Likewise, when a controller returns an RDRAM device to REFA/REFP refresh, it should start with the first bank address value (12 for the example sequence).

Figure 24-2 illustrates the requirement imposed by the  $t_{BURST}$  parameter. After PDN or NAP (when self-refresh is enabled) power states are exited, the controller must refresh all banks of the RDRAM device once during the interval  $t_{BURST}$  after the restricted interval on the ROW and COL buses. This will ensure that regardless of the state of self-refresh during PDN or NAP, the  $t_{REF, MAX}$  parameter is met for all banks. During the  $t_{BURST}$  interval, the banks may be refreshed in a single burst, or they may be scattered throughout the interval. Note that the first and last banks to be refreshed in the  $t_{BURST}$  interval are numbers 12 and 31, in order to match the example refresh sequence.

Figure 24-1 REFA/REFP Refresh Transaction Example

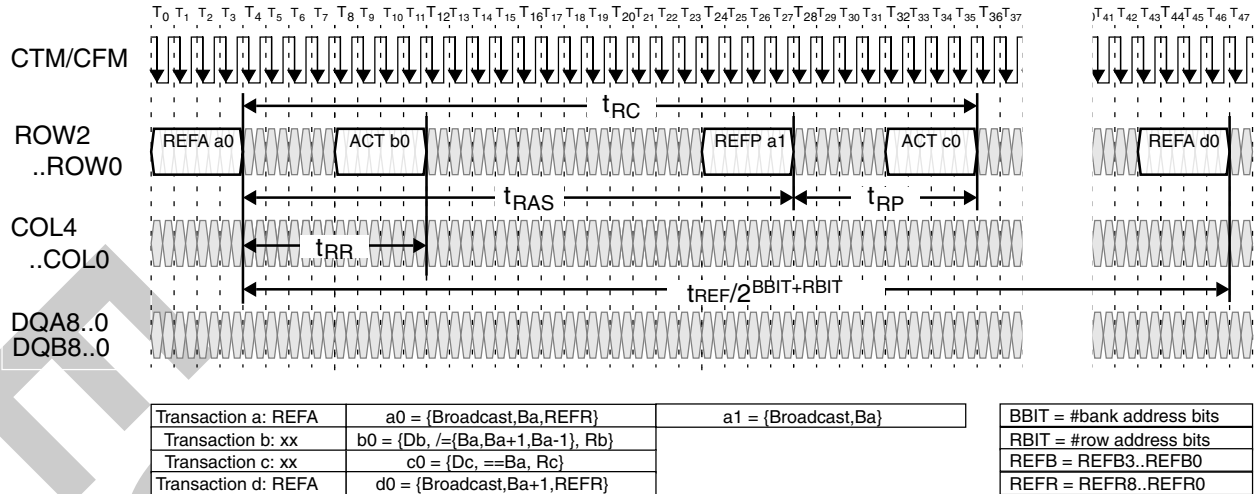
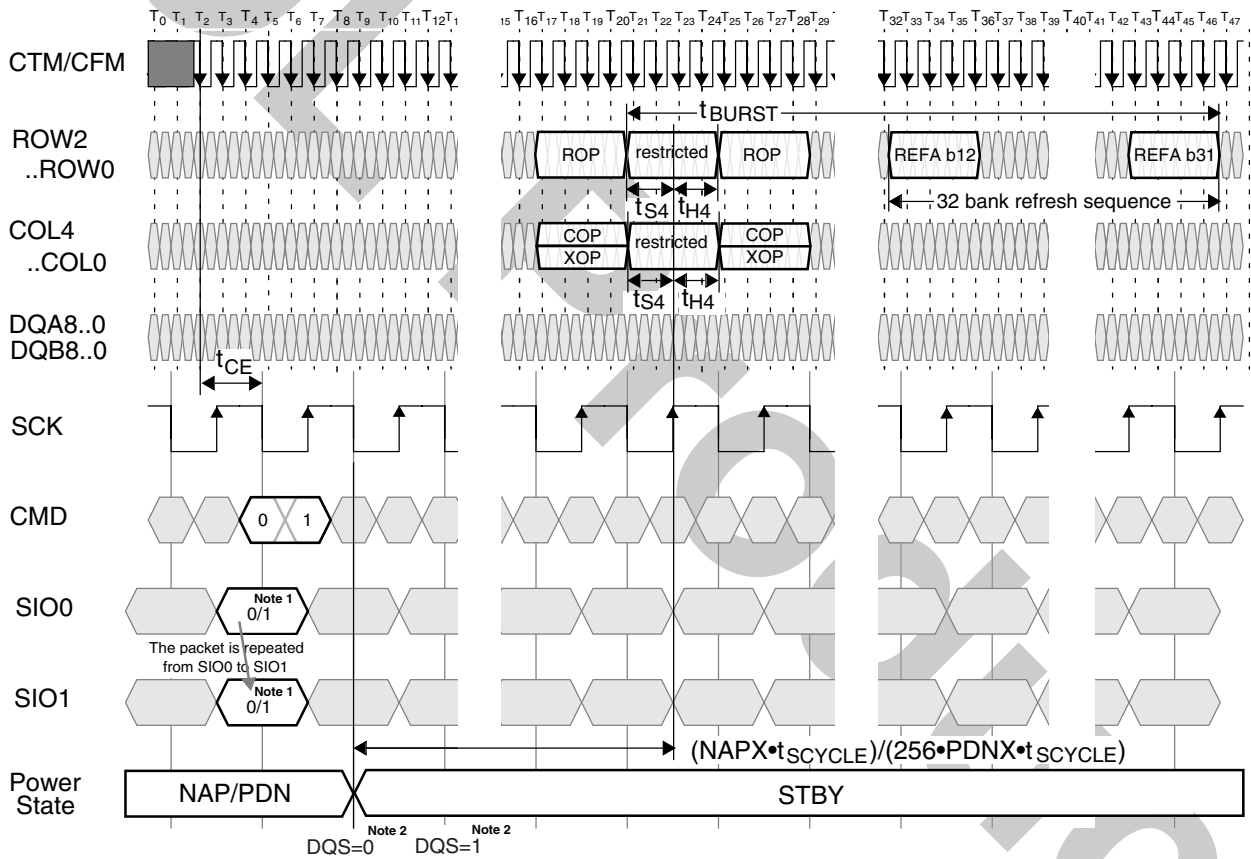

Figure 24-2 NAP/PDN Exit - tBURST Requirement



- Notes 1. Use 0 for NAP exit, 1 for PDN exit
- 2. Device selection timing slot is selected by DQS field of NAPX register

25. Current and Temperature Control

Figure 25-1 shows an example of a transaction which performs current control calibration. It is necessary to perform this operation once to every RDRAM device in every  $t_{CCTRL}$  interval in order to keep the  $I_{OL}$  output current in its proper range.

This example uses four COLX packets with a CAL command. These cause the RDRAM device to drive four calibration packets  $Q(a0)$  a time  $t_{CAC}$  later. An offset of  $t_{RDTOCC}$  must be placed between the  $Q(a0)$  packet and read data  $Q(a1)$  from the same device. These calibration packets are driven on the  $DQA4..3$  and  $DQB4..3$  wires. During current calibration the value of  $DQA5$  is undefined. The remaining  $DQA$  and  $DQB$  wires are not used during these calibration packets. The last COLX packet also contains a SAM command (concatenated with the CAL command). The RDRAM device samples the last calibration packet and adjusts its  $I_{OL}$  current value.

Unlike REF commands, CAL and SAM commands cannot be broadcast. This is because the calibration packets from different devices would interfere. Therefore, a current control transaction must be sent every  $t_{CCTRL} / N$ , where  $N$  is the number of RDRAM devices on the Channel. The device field  $Da$  of the address  $a0$  in the CAL/SAM command should be incremented after each transaction.

Figure 25-2 shows an example of a temperature calibration sequence to the RDRAM device. This sequence is broadcast once every  $t_{TEMP}$  interval to all the RDRAM devices on the Channel. The TCEN and TCAL are ROP commands, and cause the slew rate of the output drivers to adjust for temperature drift. During the quiet interval  $t_{TCQUIET}$  the devices being calibrated can't be read, but they can be written.

Figure 25-1 Current Control CAL/SAM Transaction Example

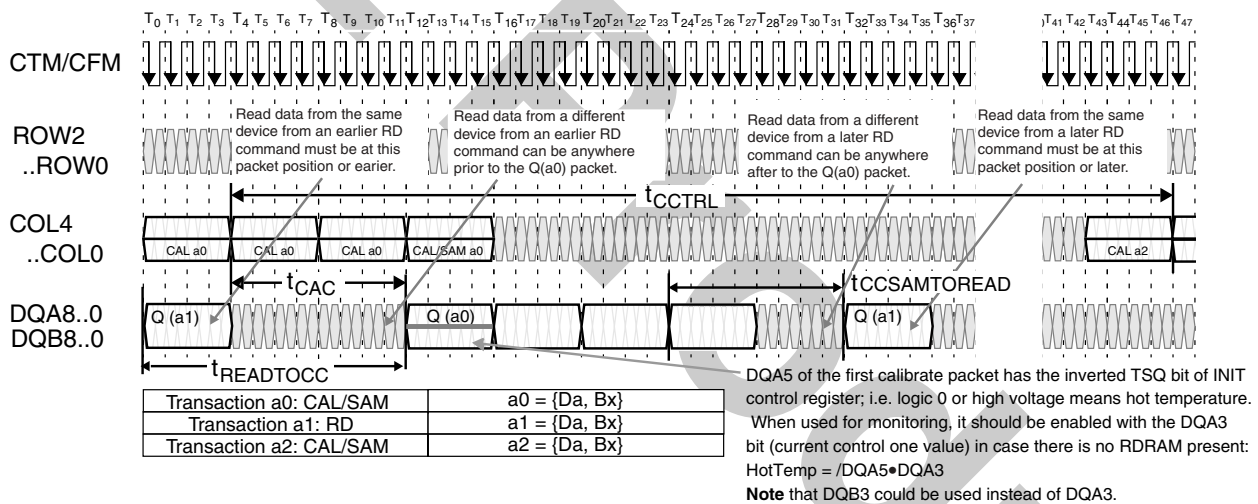
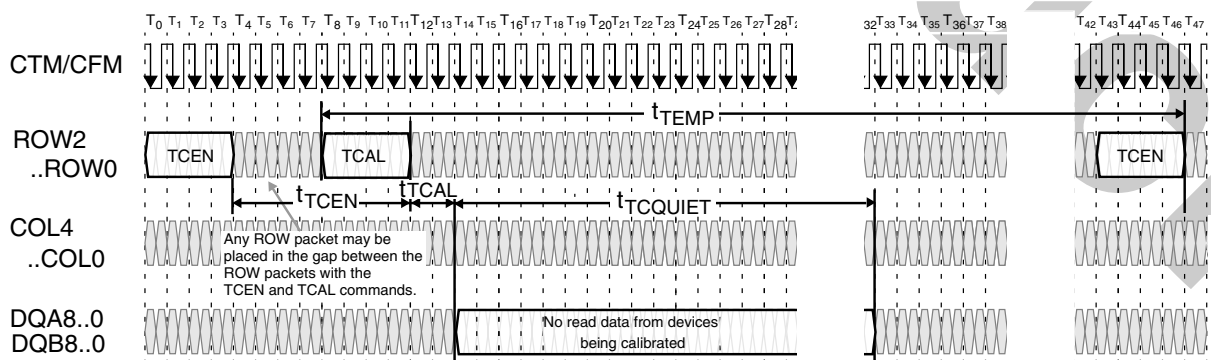

Figure 25-2 Temperature Calibration (TCEN-TCAL) Transactions to RDRAM



## 26. Electrical Conditions

## Electrical Conditions

Symbol	Parameter and Conditions	MIN.	MAX.	Unit	
T <sub>j</sub>	Junction temperature under bias	—	100	°C	
V <sub>DD</sub> , V <sub>DDa</sub>	Supply voltage	2.50 – 0.13	2.50 + 0.13	V	
V <sub>DD,N</sub> , V <sub>DDa,N</sub>	Supply voltage droop (DC) during NAP interval (t <sub>NLIMIT</sub> )	—	2.0	%	
V <sub>DD,N</sub> , V <sub>DDa,N</sub>	Supply voltage ripple (AC) during NAP interval (t <sub>NLIMIT</sub> )	–2.0	+2.0	%	
V <sub>CMOS</sub> <sup>Note1</sup>	Supply voltage for CMOS pins (2.5V controllers)	2.50 – 0.13	2.50 + 0.25	V	
	Supply voltage for CMOS pins (1.8V controllers)	1.80 – 0.1	1.80 + 0.2	V	
V <sub>TERM</sub>	Termination voltage	1.80 – 0.1	1.80 + 0.1	V	
V <sub>REF</sub>	Reference voltage	1.40 – 0.2	1.40 + 0.2	V	
V <sub>DIL</sub>	RSL data input - low voltage	t <sub>CYCLE</sub> =2.50ns	V <sub>REF</sub> – 0.5	V <sub>REF</sub> – 0.2	V
		t <sub>CYCLE</sub> =1.875ns	V <sub>REF</sub> – 0.5	V <sub>REF</sub> – 0.15	V
V <sub>DIH</sub>	RSL data input - high voltage <sup>Note2</sup>	t <sub>CYCLE</sub> =2.50ns	V <sub>REF</sub> + 0.2	V <sub>REF</sub> + 0.5	V
		t <sub>CYCLE</sub> =1.875ns	V <sub>REF</sub> + 0.15	V <sub>REF</sub> + 0.5	V
R <sub>DA</sub>	RSL input data asymmetry: R <sub>DA</sub> = (V <sub>DIH</sub> – V <sub>REF</sub> ) / (V <sub>REF</sub> – V <sub>DIL</sub> )	0.67	1.00	V	
V <sub>CM</sub>	RSL clock input - common mode V <sub>CM</sub> = (V <sub>CIH</sub> + V <sub>CIL</sub> ) / 2	1.3	1.8	V	
V <sub>CIS, CTM</sub>	RSL clock input swing : V <sub>CIS</sub> = V <sub>CIH</sub> – V <sub>CIL</sub> (CTM, CTMN pins).	0.35	1.00	V	
V <sub>CIS, CFM</sub>	RSL clock input swing : V <sub>CIS</sub> = V <sub>CIH</sub> – V <sub>CIL</sub> (CFM, CFMN pins).	0.225	1.00	V	
V <sub>IL, CMOS</sub>	CMOS input low voltage	–0.3 <sup>Note3</sup>	+ (V <sub>CMOS</sub> / 2 – 0.25)	V	
V <sub>IH, CMOS</sub>	CMOS input high voltage	V <sub>CMOS</sub> / 2 + 0.25	V <sub>CMOS</sub> + 0.3 <sup>Note4</sup>	V	

- Notes**
1. V<sub>CMOS</sub> must remain on as long as V<sub>DD</sub> is applied and cannot be turned off.
  2. V<sub>DIH</sub> is typically equal to V<sub>TERM</sub> (1.8V ± 0.1V) under DC conditions in a system.
  3. Voltage undershoot is limited to –0.7V for a duration of less than 5ns.
  4. Voltage overshoot is limited to V<sub>CMOS</sub> + 0.7V for a duration of less than 5ns.

## 27. Timing Conditions

## Timing Conditions

Symbol	Parameter		MIN.	MAX.	Unit	Figures
t <sub>CYCLE</sub>	CTM and CFM cycle times	PC800	2.50	3.33	ns	Figure 30-1
		PC1066	1.875	2.5		
t <sub>CR</sub> , t <sub>CF</sub>	CTM and CFM input rise and fall times		0.2	0.5	ns	Figure 30-1
t <sub>CH</sub> , t <sub>CL</sub>	CTM and CFM high and low times		40%	60%	t <sub>CYCLE</sub>	Figure 30-1
t <sub>TR</sub>	CTM-CFM differential	(MSE/MS=0/0)	0.0	1.0	t <sub>CYCLE</sub>	Figure 22-1
		(MSE/MS=1/1)	0.9	1.0		Figure 30-1
		(MSE/MS=1/0)	-0.1	+0.1		Figure 30-1
t <sub>DCW</sub>	Domain crossing window		-0.1	+0.1	t <sub>CYCLE</sub>	Figure 35-1
t <sub>DR</sub> , t <sub>DF</sub>	DQA/DQB/ROW/COL input rise/fall times	t <sub>CYCLE</sub> =2.50ns	0.2	0.65	ns	Figure 31-1
		t <sub>CYCLE</sub> =1.875ns	0.2	0.45	ns	
t <sub>S</sub> , t <sub>H</sub>	DQA/DQB/ROW/COL-to-CFM setup/hold time	t <sub>CYCLE</sub> =2.50ns	0.200 <sup>Note1,2</sup>	—	ns	Figure 31-1
		t <sub>CYCLE</sub> =1.875ns	0.160 <sup>Note2</sup>	—	ns	
t <sub>DR1</sub> , t <sub>DF1</sub>	SIO0, SIO1 input rise and fall times		—	5.0	ns	Figure 33-1
t <sub>DR2</sub> , t <sub>DF2</sub>	CMD,SCK input rise and fall times		—	2.0	ns	Figure 33-1
t <sub>CYCLE1</sub>	SCK cycle time - Serial control register transactions		1,000	—	ns	Figure 33-1
	SCK cycle time - Power transitions	t <sub>CYCLE</sub> =2.50ns	10	—	ns	Figure 33-1
		t <sub>CYCLE</sub> =1.875ns	7.5	—	ns	
t <sub>CH1</sub> , t <sub>CL1</sub>	SCK high and low times	t <sub>CYCLE</sub> =2.50ns	4.25	—	ns	Figure 33-1
		t <sub>CYCLE</sub> =1.875ns	3.5	—	ns	
t <sub>S1</sub>	CMD setup time to SCK rising or falling edge <sup>Note3</sup>	t <sub>CYCLE</sub> =2.50ns	1.25	—	ns	Figure 33-1
		t <sub>CYCLE</sub> =1.875ns	1.0	—	ns	
t <sub>H1</sub>	CMD hold time to SCK rising or falling edge <sup>Note3</sup>	t <sub>CYCLE</sub> =2.50ns	1.0	—	ns	Figure 33-1
		t <sub>CYCLE</sub> =1.875ns	1.0	—	ns	
t <sub>S2</sub>	SIO0 setup time to SCK falling edge		40	—	ns	Figure 33-1
t <sub>H2</sub>	SIO0 hold time to SCK falling edge		40	—	ns	Figure 33-1
t <sub>S3</sub>	PDEV setup time on DQA5..0 to SCK rising edge		0	—	ns	Figure 23-4, 33-2
t <sub>H3</sub>	PDEV hold time on DQA5..0 to SCK rising edge		5.5	—	ns	Figure 23-4, 33-2
t <sub>S4</sub>	ROW2..0, COL4..0 setup time for quiet window		-1	—	t <sub>CYCLE</sub>	Figure 23-4
t <sub>H4</sub>	ROW2..0, COL4..0 hold time for quiet window <sup>Note4</sup>		5	—	t <sub>CYCLE</sub>	Figure 23-4
t <sub>NPQ</sub>	Quiet on ROW / COL bits during NAP / PDN entry		4	—	t <sub>CYCLE</sub>	Figure 23-3
t <sub>READTOCC</sub>	Offset between read data and CC packets (same device)		12	—	t <sub>CYCLE</sub>	Figure 25-1
t <sub>CCSAMTOREAD</sub>	Offset between CC packet and read data (same device)		8	—	t <sub>CYCLE</sub>	Figure 25-1
t <sub>CE</sub>	CTM/CFM stable before NAP/PDN exit		2	—	t <sub>CYCLE</sub>	Figure 23-4
t <sub>CD</sub>	CTM/CFM stable after NAP/PDN entry		100	—	t <sub>CYCLE</sub>	Figure 23-3
t <sub>FRM</sub>	ROW packet to COL packet ATTN framing delay		7	—	t <sub>CYCLE</sub>	Figure 23-2
t <sub>NLIMIT</sub>	Maximum time in NAP mode		—	10	μs	Figure 23-1
t <sub>REF</sub>	Refresh interval		—	32	ms	Figure 24-1
t <sub>CTRL</sub>	Current control interval		34 t <sub>CYCLE</sub>	100 ms	—	Figure 25-1
t <sub>TEMP</sub>	Temperature control interval		—	100	ms	Figure 25-2
t <sub>TCEN</sub>	TCE command to TCAL command		150	—	t <sub>CYCLE</sub>	Figure 25-2
t <sub>TCAL</sub>	TCAL command to quiet window		2	2	t <sub>CYCLE</sub>	Figure 25-2
t <sub>TCQUIET</sub>	Quiet window (no read data)		140	—	t <sub>CYCLE</sub>	Figure 25-2
t <sub>PAUSE</sub>	RDRAM delay (no RSL operations allowed)		—	200	μs	Figure 22-1
t <sub>BURST</sub>	Interval after PDN or NAP (with self-refresh) exit in which all banks of the RDRAM must be refreshed at least once.		—	200	μs	Figure 24-2



- Notes**
1. This parameter also applies to a PC1066 part when operated with  $t_{\text{CYCLE}} = 2.50\text{ns}$ .
  2.  $t_{\text{S,MIN}}$  and  $t_{\text{H,MIN}}$  for other  $t_{\text{CYCLE}}$  values can be interpolated between or extrapolated from the timings at the 2 specified  $t_{\text{CYCLE}}$  values.
  3. With  $V_{\text{IL,CMOS}} = 0.5 V_{\text{CMOS}} - 0.4 \text{ V}$  and  $V_{\text{IH,CMOS}} = 0.5 V_{\text{CMOS}} + 0.4 \text{ V}$
  4. Effective hold becomes  $t_{\text{H4}}' = t_{\text{H4}} + [\text{PDNXA} \cdot 64 \cdot t_{\text{SCYCLE}} + t_{\text{PDNXB,MAX}}] - [\text{PDNX} \cdot 256 \cdot t_{\text{SCYCLE}}]$   
if  $[\text{PDNX} \cdot 256 \cdot t_{\text{SCYCLE}}] < [\text{PDNXA} \cdot 64 \cdot t_{\text{SCYCLE}} + t_{\text{PDNXB,MAX}}]$ . See **Figure 23-4**.

FOR Product

## 28. Electrical Characteristics

### Electrical Characteristics

Symbol	Parameter and Conditions		MIN.	MAX.	Unit
$\Theta_{JC}$	Junction-to-Case thermal resistance		—	0.5	°C/Watt
$I_{REF}$	$V_{REF}$ current @ $V_{REF,MAX}$		-10	+10	$\mu A$
$I_{OH}$	RSL output high current @ ( $0 \leq V_{OUT} \leq V_{DD}$ )		-10	+10	$\mu A$
$I_{ALL}$	RSL $I_{OL}$ current @ $V_{OL}=0.9 V$ , $V_{DD,MIN}$ , $T_{j,MAX}$ <sup>Note1</sup>	$t_{CYCLE}=2.50ns$	30.0	90	mA
		$t_{CYCLE}=1.875ns$	32.0	90	mA
$\Delta I_{OL}$	RSL $I_{OL}$ current resolution step		—	2.0	mA
$r_{OUT}$	Dynamic output impedance		150	—	$\Omega$
$I_{OL, NOM}$	RSL $I_{OL}$ current @ $V_{OL}=1.0 V$ <sup>Note2,3</sup>	$t_{CYCLE}=2.50ns$	26.6	30.6	mA
		$t_{CYCLE}=1.875ns$	27.1	30.1	mA
$I_{I,CMOS}$	CMOS input leakage current @ ( $0 \leq V_{I,CMOS} \leq V_{CMOS}$ )		-10.0	+10.0	$\mu A$
$V_{OL,CMOS}$	CMOS output low voltage @ $I_{OL,CMOS} = 1.0 mA$		—	0.3	V
$V_{OH,CMOS}$	CMOS output high voltage @ $I_{OH,CMOS} = -0.25 mA$		$V_{CMOS} - 0.3$	—	V

- Note**
1. This measurement is made in manual current control mode with all output device legs sinking current.
  2. This measurement is made in automatic current control mode after at least 64 current control calibration operations to a device and after CCA and CCB are initialized to a value of 64. This value applies to all DQA and DQB pins.
  3. This measurement is made in automatic current control mode with the ASYMA and ASYMB register fields set to 0.

## 29. Timing Characteristics

### Timing Characteristics

Symbol	Parameter		MIN.	MAX.	Unit	Figure(s)
$t_Q$	CTM-to-DQA/DQB output time	$t_{CYCLE} = 2.50 ns$	-0.260 <sup>Note1,2</sup>	+0.260 <sup>Note1,2</sup>	ns	Figure 32-1
		$t_{CYCLE} = 1.875 ns$	-0.195 <sup>Note2</sup>	+0.195 <sup>Note2</sup>		
$t_{QR}, t_{QF}$	DQA/DQB output rise and fall times	$t_{CYCLE} = 2.50 ns$	0.2	0.45	ns	Figure 32-1
		$t_{CYCLE} = 1.875 ns$	0.2	0.32		
$t_{Q1}$	SCK-to-SIO0 delay @ $C_{LOAD,MAX} = 20 pF$ (SD read packet)		—	10	ns	Figure 34-1
$t_{HR}$	SCK(pos)-to-SIO0 delay @ $C_{LOAD,MAX} = 20pF$ (SD read data hold)		2	—	ns	Figure 34-1
$t_{QR1}, t_{QF1}$	SIO <sub>OUT</sub> rise/fall @ $C_{LOAD,MAX} = 20 pF$		—	12	ns	Figure 34-1
$t_{PROP1}$	SIO0-to-SIO1 or SIO1-to-SIO0 delay @ $C_{LOAD,MAX} = 20 pF$		—	20	ns	Figure 34-1
$t_{NAPXA}$	NAP exit delay - phase A		—	50	ns	Figure 23-4
$t_{NAPXB}$	NAP exit delay - phase B		—	40	ns	Figure 23-4
$t_{PDNXA}$	PDN exit delay - phase A		—	4	$\mu S$	Figure 23-4
$t_{PDNXB}$	PDN exit delay - phase B		—	9,000	$t_{CYCLE}$	Figure 23-4
$t_{AS}$	ATTN-to-STBY power state delay		—	1	$t_{CYCLE}$	Figure 23-2
$t_{SA}$	STBY-to-ATTN power state delay		—	0	$t_{CYCLE}$	Figure 23-2
$t_{ASN}$	ATTN/STBY-to-NAP power state delay		—	8	$t_{CYCLE}$	Figure 23-3
$t_{ASP}$	ATTN/STBY-to-PDN power state delay		—	8	$t_{CYCLE}$	Figure 23-3

- Notes**
1. This parameter also applies to a PC1066 part when operated with  $t_{CYCLE} = 2.50 ns$ .
  2.  $t_{Q,MIN}$  and  $t_{Q,MAX}$  for other  $t_{CYCLE}$  values can be interpolated between or extrapolated from the timings at the 2 specified  $t_{CYCLE}$  values.

30. RSL Clcking

Figure 30-1 is a timing diagram which shows the detailed requirements for the RSL clock signals on the Channel.

The CTM and CTMN are differential clock inputs used for transmitting information on the DQA and DQB, outputs. Most timing is measured relative to the points where they cross. The  $t_{CYCLE}$  parameter is measured from the falling CTM edge to the falling CTM edge. The  $t_{CL}$  and  $t_{CH}$  parameters are measured from falling to rising and rising to falling edges of CTM. The  $t_{CR}$  and  $t_{CF}$  rise- and fall-time parameters are measured at the 20 % and 80 % points.

The CFM and CFMN are differential clock outputs used for receiving information on the DQA, DQB, ROW and COL outputs. Most timing is measured relative to the points where they cross. The  $t_{CYCLE}$  parameter is measured from the falling CFM edge to the falling CFM edge. The  $t_{CL}$  and  $t_{CH}$  parameters are measured from falling to rising and rising to falling edges of CFM. The  $t_{CR}$  and  $t_{CF}$  rise- and fall-time parameters are measured at the 20 % and 80 % points. The  $t_{TR}$  parameters specifies the phase difference that may be tolerated with respect to the CTM and CFM differential clock inputs (the CTM pair is always earlier).

Figure 30-1 RSL Timing - Clock Signals

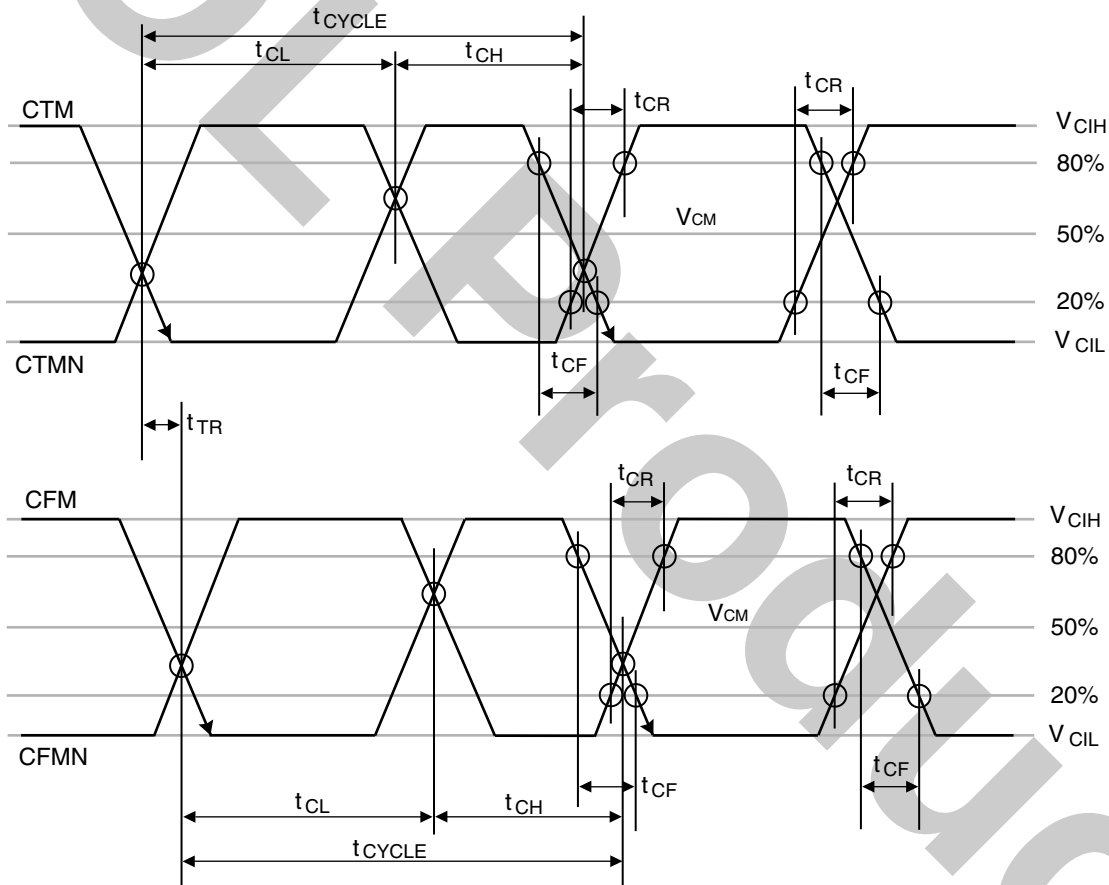

31. RSL - Receive Timing

Figure 31-1 is a timing diagram which shows the detailed requirements for the RSL input signals on the Channel. The DQA, DQB, ROW, and COL signals are inputs which receive information transmitted by a Direct RAC on the Channel. Each signal is sampled twice per  $t_{CYCLE}$  interval. The set/hold window of the sample points is  $t_s/t_h$ . The sample points are centered at the 0 % and 50 % points of a cycle, measured relative to the crossing points of the falling CFM clock edge. The set and hold parameters are measured at the  $V_{REF}$  voltage point of the input transition. The  $t_{DR}$  and  $t_{DF}$  rise- and fall-time parameters are measured at the 20 % and 80 % points of the input transition.

Figure 31-1 RSL Timing - Data Signals for Receive

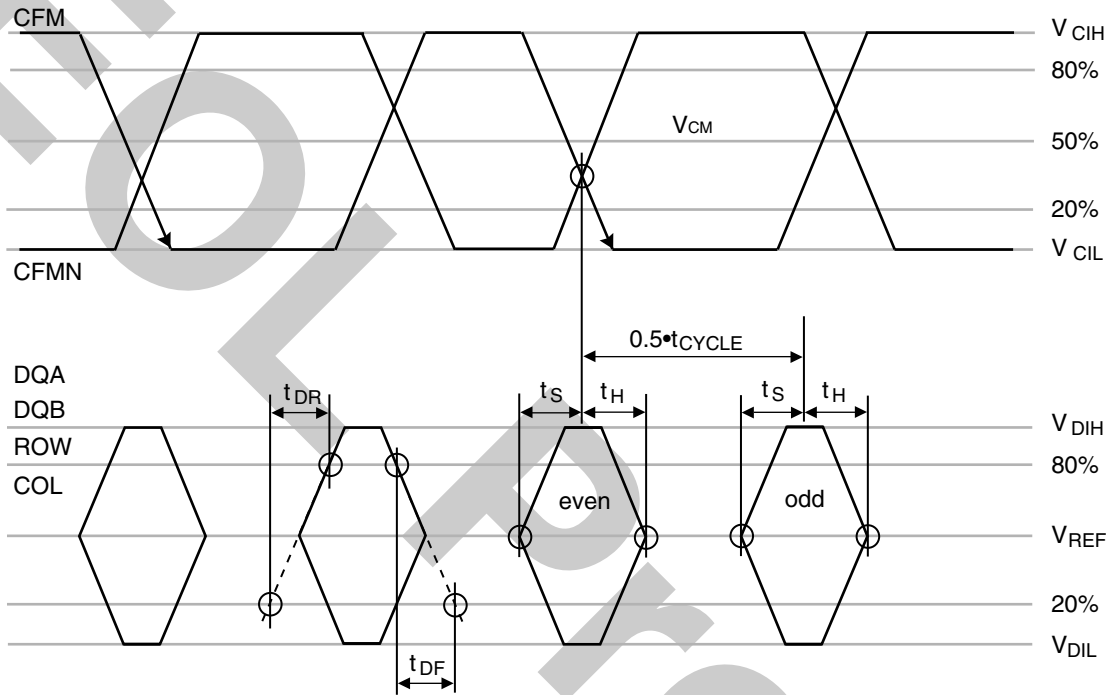

32. RSL - Transmit Timing

Figure 32-1 is a timing diagram which shows the detailed requirements for the RSL output signals on the Channel. The DQA and DQB signals are outputs to transmit information that is received by a Direct RAC on the Channel. Each signal is driven twice per  $t_{CYCLE}$  interval. The beginning and end of the even transmit window is at the 75 % point of the previous cycle and at the 25 % point of the current cycle. The beginning and end of the odd transmit window is at the 25 % point and at the 75 % point of the current cycle. These transmit points are measured relative to the crossing points of the falling CTM clock edge. The size of the actual transmit window is less than the ideal  $t_{CYCLE}/2$ , as indicated by the non-zero valued of  $t_{Q,MIN}$  and  $t_{Q,MAX}$ . The  $t_Q$  parameters are measured at the 50 % voltage point of the output transition.

The  $t_{QR}$  and  $t_{QF}$  rise- and fall-time parameters are measured at the 20 % and 80 % points of the output transition.

Figure 32-1 RSL Timing - Data Signals for Transmit

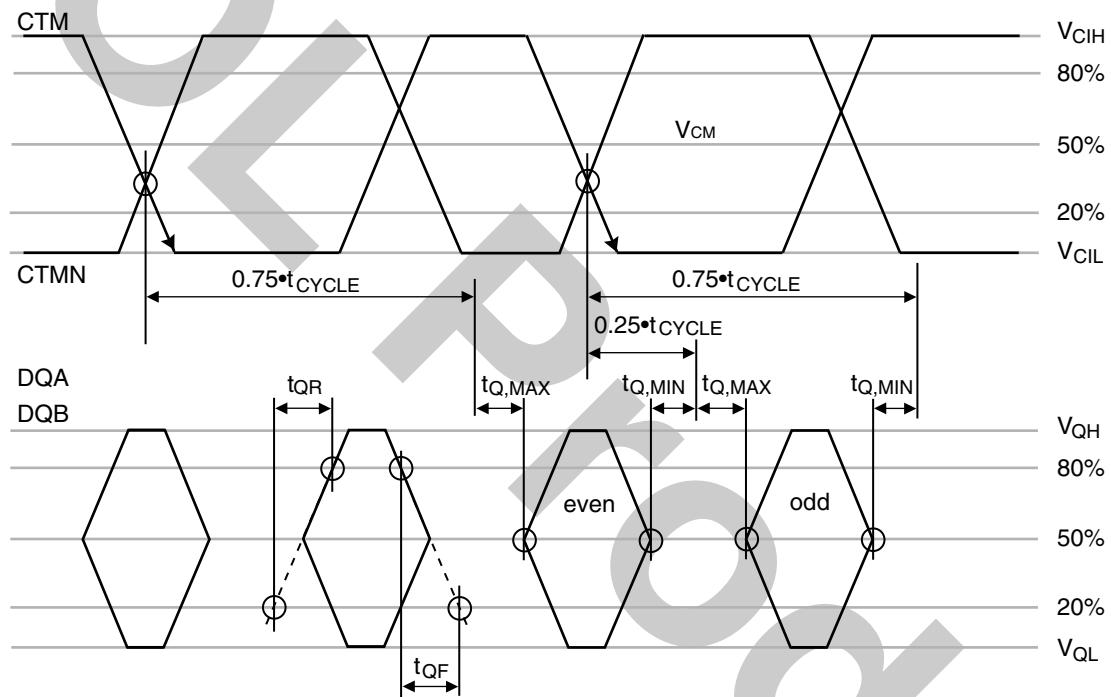

33. CMOS - Receive Timing

Figure 33-1 is a timing diagram which shows the detailed requirements for the CMOS input signals.

The CMD and SIO0 signals are inputs which receive information transmitted by a controller (or by another RDRAM DEVICE'Ss SIO1 output). SCK is the CMOS clock signal driven by the controller. All signals are high true.

The cycle time, high phase time, and low phase time of the SCK clock are  $t_{CYCLE1}$ ,  $t_{CH1}$  and  $t_{CL1}$ , all measured at the 50 % level. The rise and fall times of SCK, CMD, and SIO0 are  $t_{DR1}$  and  $t_{DF1}$ , measured at the 20 % and 80 % levels.

The CMD signal is sampled twice per  $t_{CYCLE1}$  interval, on the rising edge (odd data) and the falling edge (even data). The set/hold window of the sample points is  $t_{S1}/t_{H1}$ . The SCK and CMD timing points are measured at the 50 % level.

The SIO0 signal is sampled once per  $t_{CYCLE1}$  interval on the falling edge. The set/hold window of the sample points is  $t_{S2}/t_{H2}$ . The SCK and SIO0 timing points are measured at the 50 % level.

Figure 33-1 CMOS Timing - Data Signals for Receive

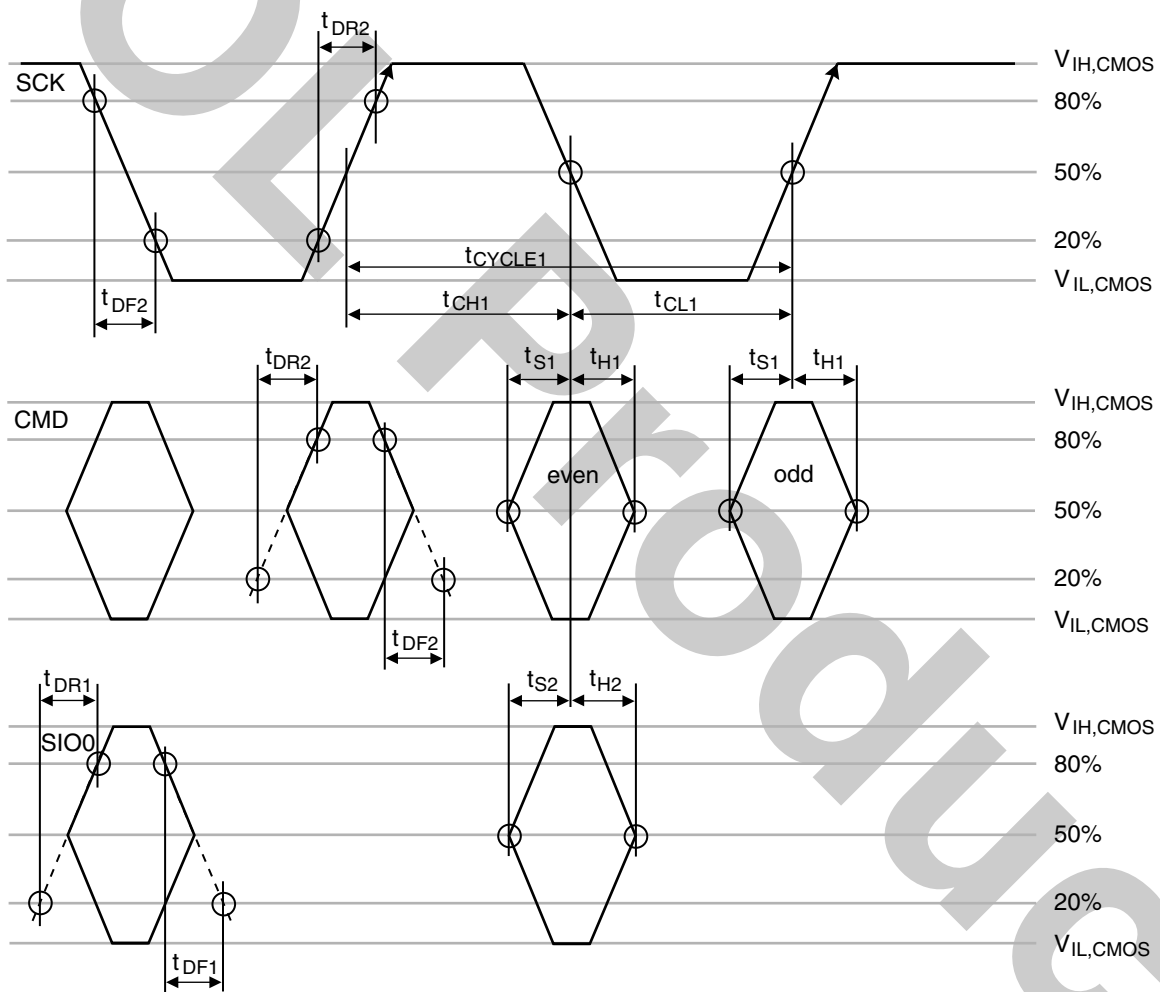

The SCK clock is also used for sampling data on RSL input in one situation. Figure 23-4 shows the PDN and NAP exit sequences. If the PSX field of the INIT register is one (Figure 22-1 control registers (1/7) "INIT Register"), then the PDN and NAP exit sequences are broadcast; i.e. all RDRAM devices that are in PDN or NAP will perform the exit sequence. If the PSX field of the INIT register is zero, then the PDN and NAP exit sequences are directed; i.e. only one RDRAM that is in PDN or NAP will perform the exit sequence.

The address of that RDRAM is specified on the DQA[5:0] bus in the set hold window  $t_{S3}/t_{H3}$  around the rising edge of SCK. This is shown Figure 33-2. The SCK timing point is measured at the 50 % level, and the DQA [5:0] bus signals are measured at the  $V_{REF}$  level.

Figure 33-2 CMOS Timing - Device Address for NAP or PDN Exit

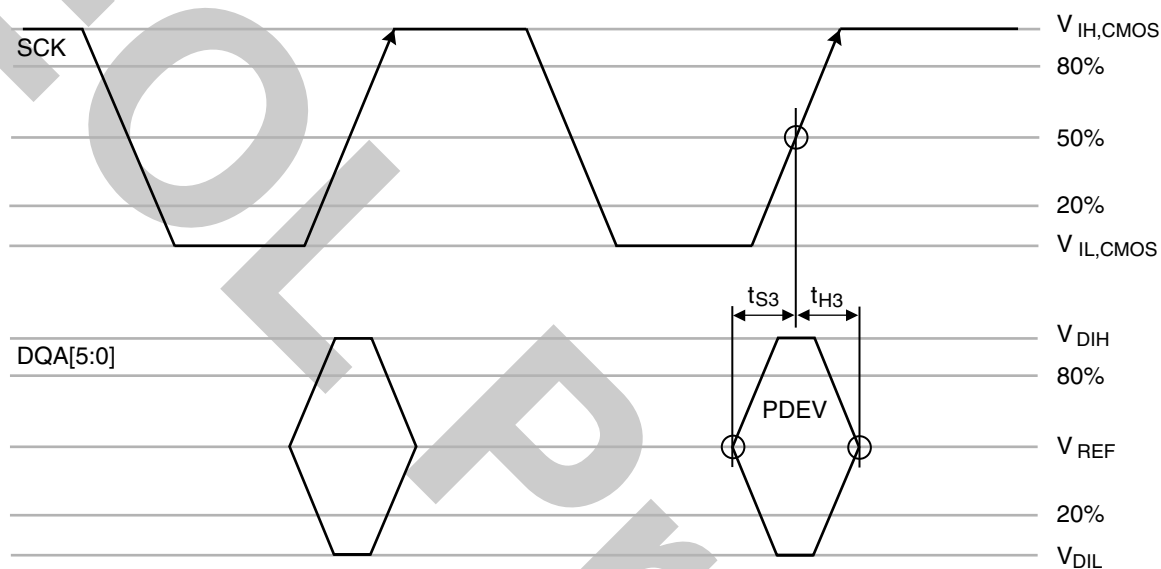

34. CMOS - Transmit Timing

Figure 34-1 is a timing diagram which shows the detailed requirements for the CMOS output signals. The SIO0 signal is driven once per  $t_{CYCLE1}$  interval on the falling edge. The clock-to-output window is  $t_{Q1,MIN} / t_{Q1,MAX}$ . The SCK and SIO0 timing points are measured at the 50 % level. The rise and fall times of SIO0 are  $t_{QR1}$  and  $t_{QF1}$ , measured at the 20 % and 80 % levels.

Figure34-1 also shows the combinational path connecting SIO0 to SIO1 and the path connecting SIO1 to SIO0 (read data only). The  $t_{PROP1}$  parameter specified this propagation delay. The rise and fall times of SIO0 and SIO1 input must be  $t_{DR1}$  and  $t_{DF1}$ , measured at the 20 % and 80 % levels. The rise and fall times of SIO0 and SIO1 outputs are  $t_{QR1}$  and  $t_{QF1}$ , measured at the 20 % and 80 % levels.

Figure 34-1 CMOS Timing - Data Signals for Transmit

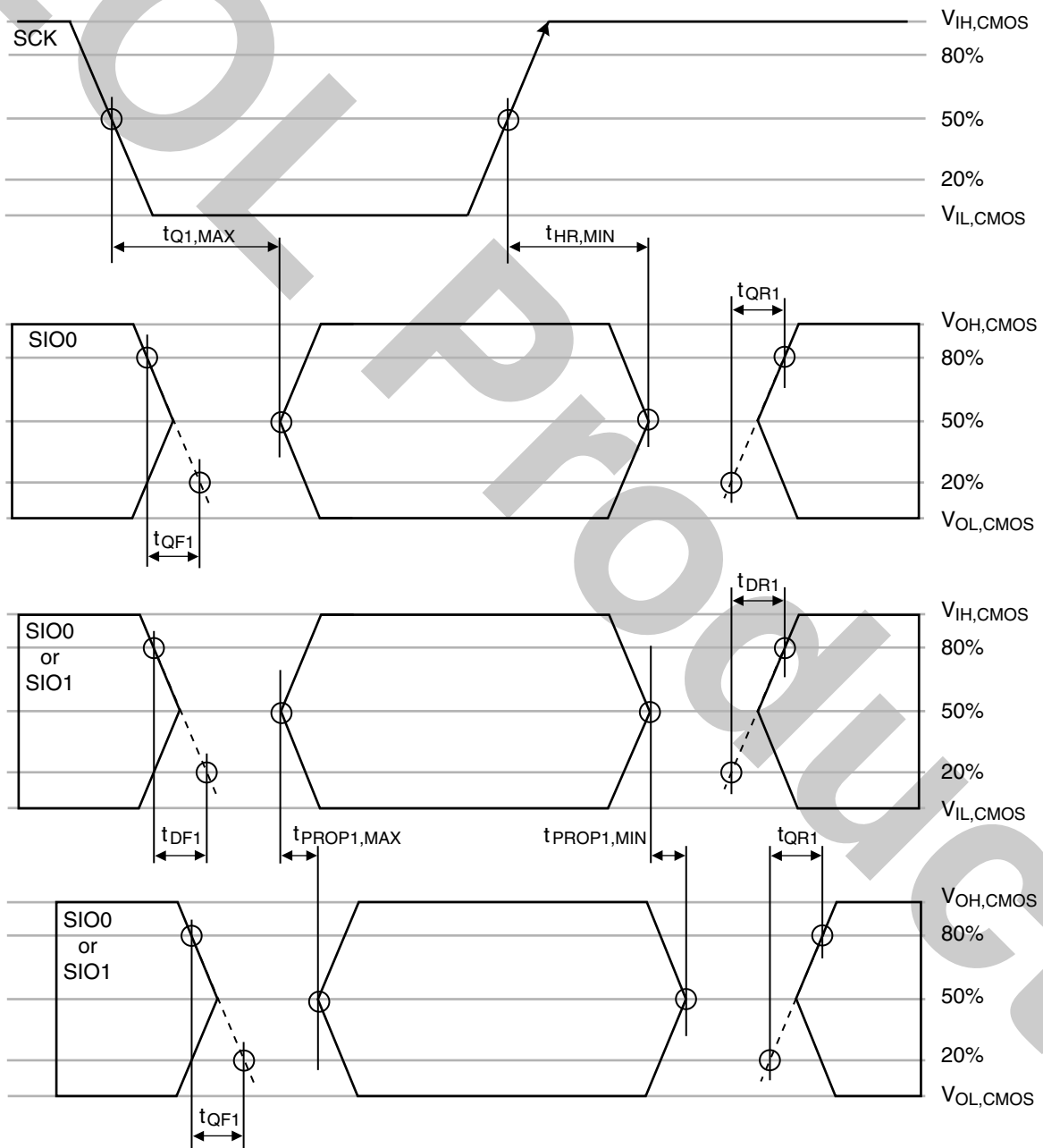



### 35. RSL - Domain Crossing Window

When read data is returned by the RDRAM device, information must cross from the receive clock domain (CFM) to the transmit clock domain (CTM). The  $t_{TR}$  parameter permits the CFM to CTM phase to vary though an entire cycle ; i.e. there is no restriction on the alignment of these two clocks. A second parameter  $t_{DCW}$  is needed in order to describe how the delay between a RD command packet and read data packet varies as a function of the  $t_{TR}$  value.

Figure 35-1 shows this timing for five distinct values of  $t_{TR}$ . Case A ( $t_{TR}=0$ ) is what has been used throughout this document. The delay between the RD command and read data is  $t_{CAC}$ . As  $t_{TR}$  varies from zero to  $t_{CYCLE}$  (cases A through E), the command to data delay is  $(t_{CAC}-t_{TR})$ . When the  $t_{TR}$  value is in the range 0 to  $t_{DCW,MAX}$ , the command to data delay can also be  $(t_{CAC}-t_{TR}-t_{CYCLE})$ . This is shown as cases A' and B' (the gray packets). Similarly, when the  $t_{TR}$  value is in the range  $(t_{CYCLE}+t_{DCW,MIN})$  to  $t_{CYCLE}$ , the command to data delay can also be  $(t_{CAC}-t_{TR}+t_{CYCLE})$ . This is shown as cases D' and E' (the gray packets). The RDRAM device will work reliably with either the white or gray packet timing. The delay value is selected at initialization, and remains fixed thereafter.

Figure 35-1 RSL Timing - Crossing Read Domains

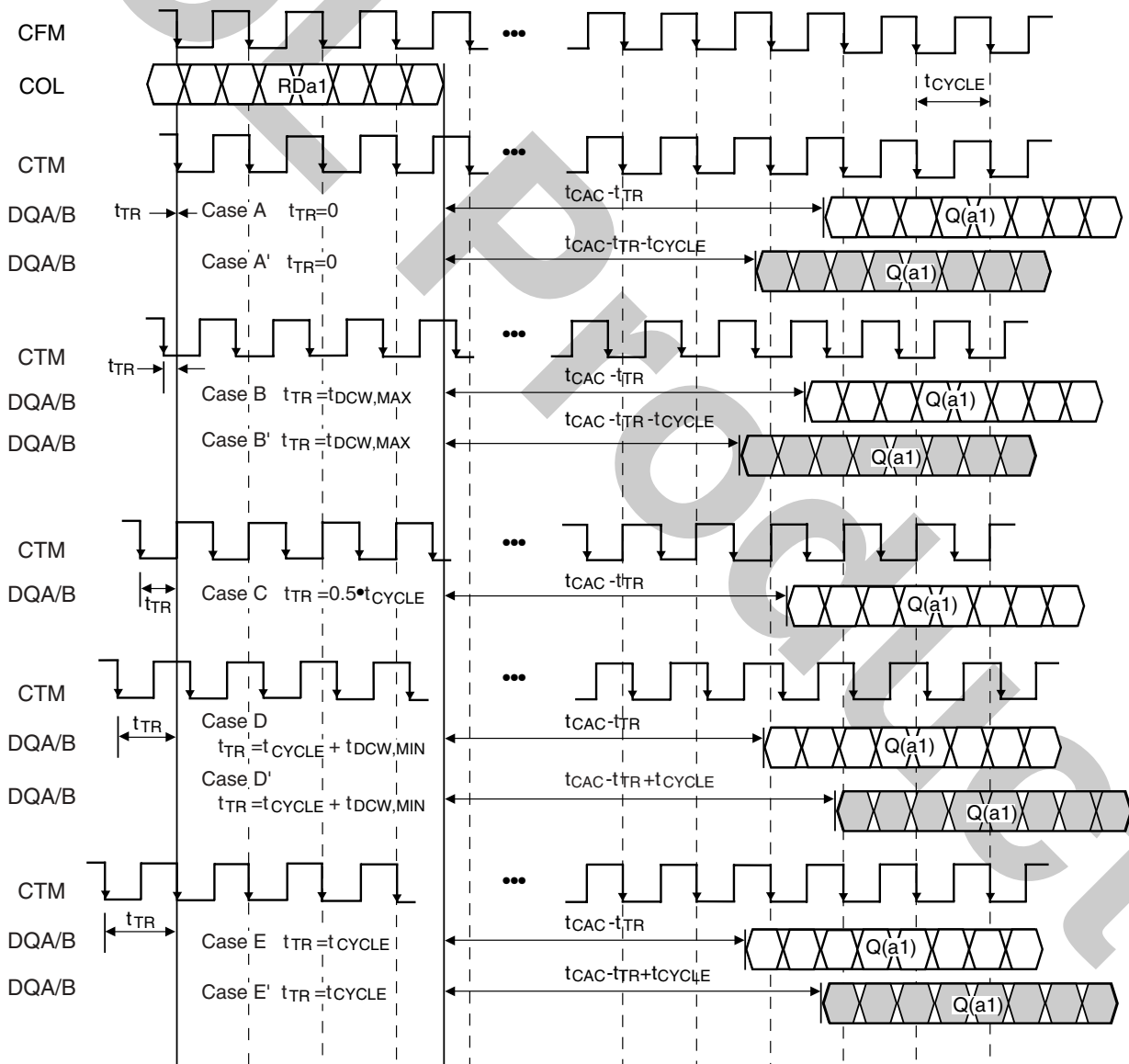

## 36. Timing Parameters

## Timing Parameters Summary

Parameter	Description	MIN.				MAX.	Units	Figures
		PC1066		PC800				
		-AEP (-32P)	-AE (-32)	-AD (-35)	-8C (-40)			
t <sub>RC</sub>	Row Cycle time of RDRAM banks - the interval between ROWA packets with ACT commands to the same bank.	28	28	32	28	—	t <sub>CYCLE</sub>	Figure13-1 Figure14-1
t <sub>TRAS</sub>	RAS-asserted time of RDRAM bank - the interval between ROWA packet with ACT command and next ROWR packet with PRER <sup>Note 1</sup> command to the same bank.	20	20	22	20	Note 2 64μs	t <sub>CYCLE</sub>	Figure13-1 Figure14-1
t <sub>RP</sub>	Row Precharge time of RDRAM banks - the interval between ROWR packet with PRER <sup>Note 1</sup> command and next ROWA packet with ACT command to the same bank.	8	8	10	8	—	t <sub>CYCLE</sub>	Figure13-1 Figure14-1
t <sub>PP</sub>	Precharge-to-precharge time of RDRAM device - the interval between successive ROWR packets with PRER <sup>Note 1</sup> commands to any banks of the same device.	8	8	8	8	—	t <sub>CYCLE</sub>	Figure10-3
t <sub>RR</sub>	RAS-to-RAS time of RDRAM device - the interval between successive ROWA packets with ACT commands to any banks of the same device.	8	8	8	8	—	t <sub>CYCLE</sub>	Figure12-1
t <sub>RCD</sub>	RAS-to-CAS Delay - the interval from ROWA packet with ACT command to COLC packet with RD or WR command. Note - the RAS-to-CAS delay seen by the RDRAM core (t <sub>RCD-C</sub> ) is equal to t <sub>RCD-C</sub> = 1 + t <sub>RCD</sub> because of differences in the row and column paths through the RDRAM interface.	9	9	9	7	—	t <sub>CYCLE</sub>	Figure13-1 Figure14-1
t <sub>CAC</sub>	CAS Access delay - the interval from RD command to Q read data. The equation for t <sub>CAC</sub> is given in the TPARM register in Figure 22-1(5/7).	8	9	9	8	12	t <sub>CYCLE</sub>	Figure4-1
t <sub>CWD</sub>	CAS Write Delay - interval from WR command to D write data.	6	6	6	6	6	t <sub>CYCLE</sub>	Figure4-1
t <sub>CC</sub>	CAS-to-CAS time of RDRAM bank - the interval between successive COLC commands.	4	4	4	4	—	t <sub>CYCLE</sub>	Figure13-1 Figure14-1
t <sub>PACKET</sub>	Length of ROWA, ROWR, COLC, COLM or COLX packet.	4	4	4	4	4	t <sub>CYCLE</sub>	Figure2-1
t <sub>RTR</sub>	Interval from COLC packet with WR command to COLC packet which causes retire, and to COLM packet with bytemask.	8	8	8	8	—	t <sub>CYCLE</sub>	Figure15-1
t <sub>OFFP</sub>	The interval (offset) from COLC packet with RDA command, or from COLC packet with retire command (after WRA automatic precharge), or from COLC packet with PREC command, or from COLX packet with PREX command to the equivalent ROWR packet with PRER. The equation for t <sub>OFFP</sub> is given in the TPARM register in Figure 22-1(5/7).	4	4	4	4	4	t <sub>CYCLE</sub>	Figure14-2
t <sub>RDP</sub>	Interval from last COLC packet with RD command to ROWR packet with PRER.	4	4	4	4	—	t <sub>CYCLE</sub>	Figure13-1
t <sub>RTP</sub>	Interval from last COLC packet with automatic retire command to ROWR packet with PRER.	4	4	4	4	—	t <sub>CYCLE</sub>	Figure14-1

**Notes 1.** Or equivalent PREC or PREX command. See Figure 12-2.

**2.** This is a constraint imposed by the core, and is therefore in units of ms rather than t<sub>CYCLE</sub>.

### 37. Absolute Maximum Ratings

#### Absolute Maximum Ratings

Symbol	Parameter	MIN.	MAX.	Unit
$V_{I,ABS}$	Voltage applied to any RSL or CMOS pin with respect to GND	-0.3	$V_{DD} + 0.3$	V
$V_{DD,ABS}, V_{DDa,ABS}$	Voltage on $V_{DD}$ and $V_{DDa}$ with respect to GND	-0.5	$V_{DD} + 1.0$	V
$T_{STORE}$	Storage temperature	-50	+100	°C

**Caution** Exposing the device to stress above those listed in Absolute Maximum Ratings could cause permanent damage. The device is not meant to be operated under conditions outside the limits described in the operational section of this specification. Exposure to Absolute Maximum Rating conditions for extended periods may affect device reliability.

### 38. $I_{DD}$ - Supply Current Profile

#### $I_{DD}$ - Supply Current Profile

$I_{DD}$ value	RDRAM Power Stated Steady-State Transaction Rates <sup>Note 1</sup>	@ $t_{CYCLE}$	MIN.	MAX.	Unit
$I_{DD,PDN}$	Device in PDN. self-refresh enabled and INIT.LSR=0	2.50 ns/1.875 ns	—	6.0	mA
$I_{DD,NAP}$	Device in Nap.	2.50 ns/1.875 ns	—	4.0	mA
$I_{DD,STBY}$	Device in STBY. This is the average for a device in STBY with (1) no packets on the channel, and (2) with packets sent to other devices.	2.50 ns	—	70	mA
		1.875 ns	—	90	
$I_{DD,ATTN}$	Device in ATTN. This is the average for a device in ATTN with (1) no packets on the channel, and (2) with packets sent to other devices.	2.50 ns	—	100	mA
		1.875 ns	—	130	
$I_{DD,ATTN-W}$	Device in ATTN. ACT command every $8 \cdot t_{CYCLE}$ , PRE command every $8 \cdot t_{CYCLE}$ , WR command every $4 \cdot t_{CYCLE}$ and data is 1100..1100.	2.50 ns	—	530	mA
		1.875 ns	—	680	
$I_{DD,ATTN-R}$	Device in ATTN. ACT command every $8 \cdot t_{CYCLE}$ , PRE command every $8 \cdot t_{CYCLE}$ , RD command every $4 \cdot t_{CYCLE}$ and data is 1111..1111 <sup>Note 2</sup> .	2.50 ns	—	520	mA
		1.875 ns	—	660	

**Notes 1.** The CMOS interface consumes power in all power states.

**2.** This does not include the  $I_{OL}$  sink current. The RDRAM device dissipates  $I_{OL} \cdot V_{OL}$  in each output driver when a logic one is driven.

39. Capacitance and Inductance

Figure 39-1 shows the equivalent load circuit of the RSL and CMOS pins. The circuit models the load that the device presents to the Channel.

This circuit does not include pin coupling effects that are often present in the packaged device. Because coupling effects make the effective single-pin inductance  $L_i$ , and capacitance  $C_i$ , a function of neighboring pins, these parameters are intrinsically data-dependent. For purposes of specifying the device electrical loading on the Channel, the effective  $L_i$  and  $C_i$  are defined as the worst-case values over all specified operating conditions.

$L_i$  is defined as the effective pin inductance based on the device pin assignment. Because the pad assignment places each RSL signal adjacent to an AC ground (a GND or  $V_{DD}$  pin), the effective inductance must be defined based on this configuration. Therefore,  $L_i$  assumes a loop with the RSL pin adjacent to an AC ground.

$C_i$  is defined as the effective pin capacitance based on the device pin assignment. It is the sum of the effective package pin capacitance and the IO pad capacitance.

Figure 39-1 Equivalent Load Circuit for RSL Pins

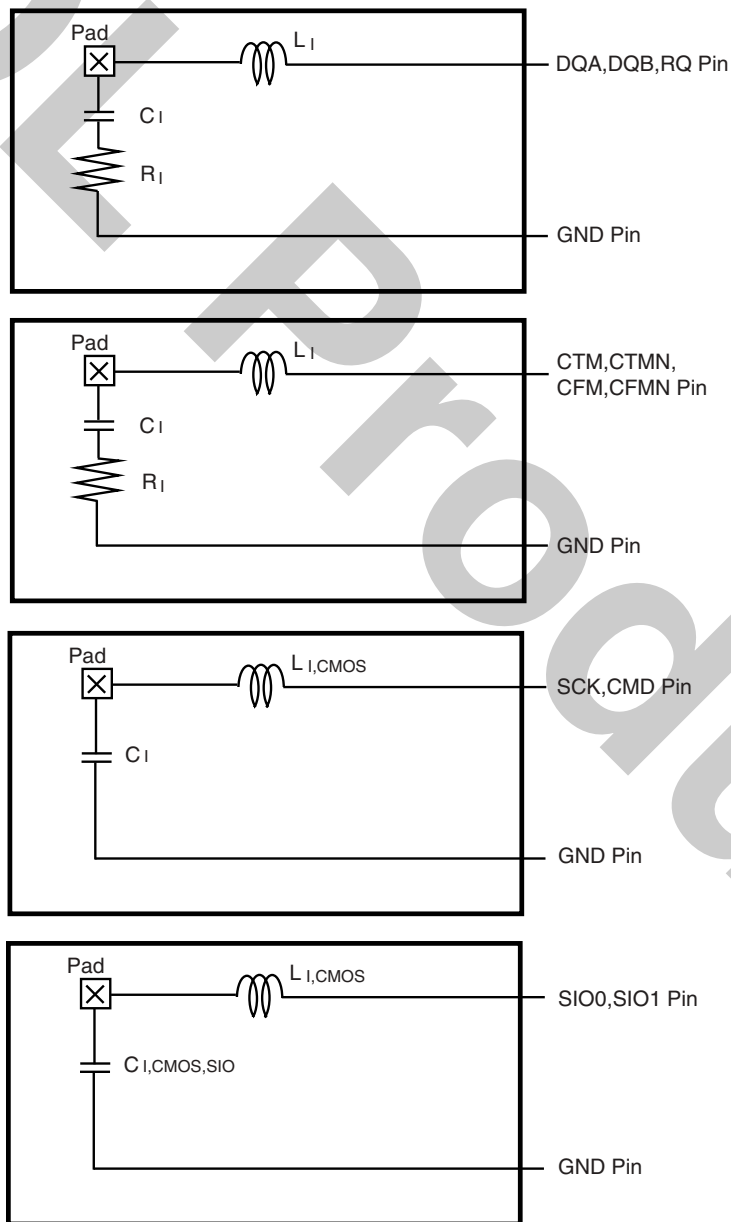

## RSL Pin Parasitics

Symbol	Parameter and Conditions - RSL pins		MIN.	MAX.	Unit
L <sub>i</sub>	RSL effective input inductance	1066 MHz	–	3.5	pF
		800 MHz	–	4.0	
L <sub>12</sub>	Mutual inductance between any DQA or DQB RSL signals.		–	0.2	nH
	Mutual inductance between any ROW or COL RSL signals.		–	0.6	nH
ΔL <sub>i</sub>	Difference in L <sub>i</sub> value between any RSL pins of a single device.		–	1.8	nH
C <sub>i</sub>	RSL effective input capacitance <sup>Note</sup>	1066 MHz	2.0	2.3	pF
		800 MHz	2.0	2.4	
C <sub>12</sub>	Mutual capacitance between any RSL signals.		–	0.1	pF
ΔC <sub>i</sub>	Difference in C <sub>i</sub> value between any RSL pins of a single device.		–	0.06	pF
R <sub>i</sub>	RSL effective input resistance	1066 MHz	4	10	Ω
		800 MHz	4	15	

**Note** This value is a combination of the device IO circuitry and package capacitances measured at VDD = 2.5 V and f = 400 MHz with pin based at 1.4 V.

## CMOS Pin Parasitics

Symbol	Parameter and Conditions - CMOS pins		MIN.	MAX.	Unit
L <sub>i,CMOS</sub>	CMOS effective input inductance		–	8.0	nH
C <sub>i,CMOS</sub>	CMOS effective input capacitance (SCK,CMD) <sup>Note</sup>		1.7	2.1	pF
C <sub>i,CMOS,SIO</sub>	CMOS effective input capacitance (SIO1,SIO0) <sup>Note</sup>		–	7.0	pF

**Note** This value is a combination of the device IO circuitry and package capacitances.

#### 40. Interleaved Device Mode

Interleaved Device Mode permits a group of eight RDRAM devices on the Channel to collectively respond to a command. The purpose of this collective response is to limit the number of bits in each dualoct data packet which are read from or written to a single RDRAM device. This capability permits a memory controller to implement hardware for fault detection and correction that can tolerate the complete internal failure of one RDRAM device on a Channel.

The IDM bit of the INIT control register enables this fault tolerant operating mode. When it is set, the RDRAM device will interpret the DR4..0 and DC4..0 fields of the ROW and COLC packets differently. Figure 40-1 shows the differences using an example system with eight RDRAM devices.

The DEVID4..0 registers of these RDRAM devices are initialized to "00000" through "00111". However, when the IDM bit is set, only the upper two bits (DEVID4..3) will be compared to the DR4..3 and DC4..3 fields. This means that ROW and COLC packets will be executed by groups of eight RDRAM devices, with a Channel containing from one to four of these groups. The low-order DR2..0 bits are not used when IDM is set, and the low-order DC2..0 bits have a modified function described below.

With IDM set, a directed ACT or PRE command in a ROW packet causes eight RDRAM devices to perform the indicated operation. Likewise, when a RD or WR command is specified in a COLC command, the selected group of eight RDRAM devices responds. When using IDM, devices must be added to the Channel in groups of eight. An application will typically make the IDM bit setting the same for all RDRAM devices on a Channel.

The mechanism for indicating a broadcast ROW packet (DR4F and DR4T are both set to one) is not affected by the setting of the IDM bit; i.e. IDM mode does not change the broadcast ROW packet mechanism.

Likewise, the COLX fields (DX4..0, XOP4..0, and BX5..0) are not changed by IDM mode - all COLX packets are directed to a single device.

When the IDM bit is set, COLM packets should not be used (the M bit should be set to zero, selecting only COLX packets). This is because the mapping of bytes to RDRAM device storage cells is changed by IDM mode.

Returning to Figure 40-1, the remaining fields of the ROW and COLC packets are interpreted in the same way regardless of the setting of the IDM bit - IDM mode does not affect these fields. Specifically, the BR5..0 and BC5..0 fields of the ROW and COLC packets are used to select one of the banks just as when IDM is not set. The R8..0 field of the ROW packet selects a row of the selected (BR5..0) bank to load into the bank's sense amp. And the C6..0 field selects one dualoct of the selected (BC5..0) bank's sense amp.

The IDM bit affects what is done with this selected dualoct. When IDM is not set, the dualoct is driven onto the Channel by the single selected RDRAM device. When IDM is set, each RDRAM device of the eight device group selected by DC4..3 drives 16 or 24 bits (x18 device) of the 144-bit dualoct. The bits driven are a function of the DEVID2..0 RDRAM register field, the DC2..0 COLC packet field, and the device width (x18). Figure 40-1 shows the mapping that is appropriate for DC2..0=000.

Figure 40-2 and Figure 40-3 show the mapping for all eight values of DC2..0. There are eight mappings, which are rotated among the eight devices using the following equation:

$$\text{Pin} = 7 - 4 \bullet (\text{DEVID2} \wedge \text{DC2}) - 2 \bullet (\text{DEVID1} \wedge \text{DC1}) - 1 \bullet (\text{DEVID0} \wedge \text{DC0}) \quad (\text{Eq 1})$$

where " $\wedge$ " is the exclusive-or function. "Pin" is the pin number that is driven by the RDRAM device with the DEVID2..0 value. For example, Pin=0 means the RDRAM drives DQA0 and DQB0, and so forth. The DQA8 pin is always driven with DQA7, and DQB8 is always driven with DQB6 for x18 devices. For x16 devices, the DQA8 and DQB8 pins are not used. For each of the eight mappings, the eight-RDRAM group supplies a complete dualoct. As the application steps through eight values of DC2..0, all the bits of the eight underlying dualocts will be accessed. Thus, an eight-RDRAM group appears to be a single RDRAM device with eight times the normal page size, with the DC2..0 field providing the extra column addressing information (beyond what C6..0 provides).

Figure 40-1 ACT, PRE, RD, and WR Commands for Eight RDRAM System with IDM = 1

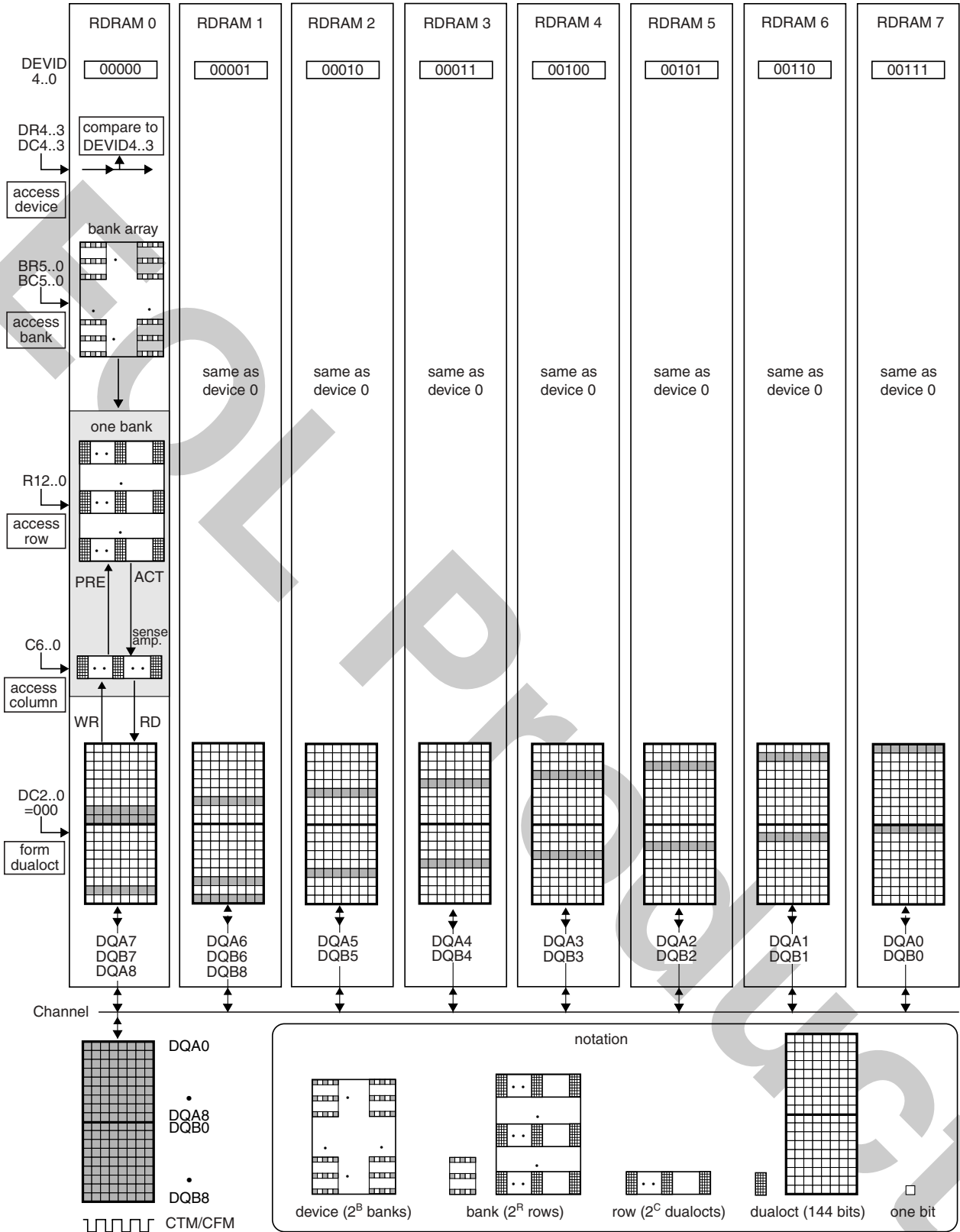

Figure 40-2 Mapping from DEVID2..0 and DC2..0 Fields to DQ Packet with IDM = 1

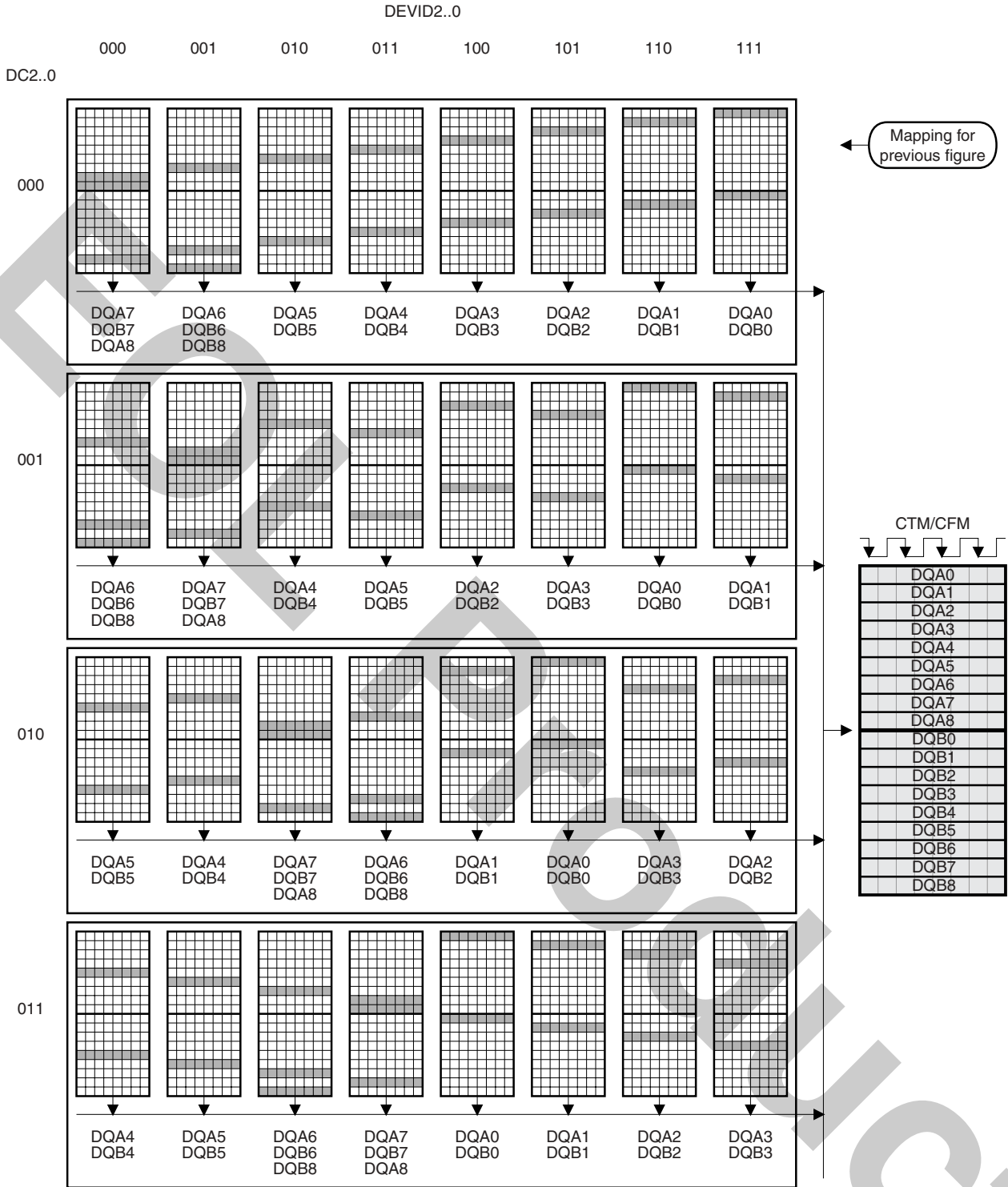
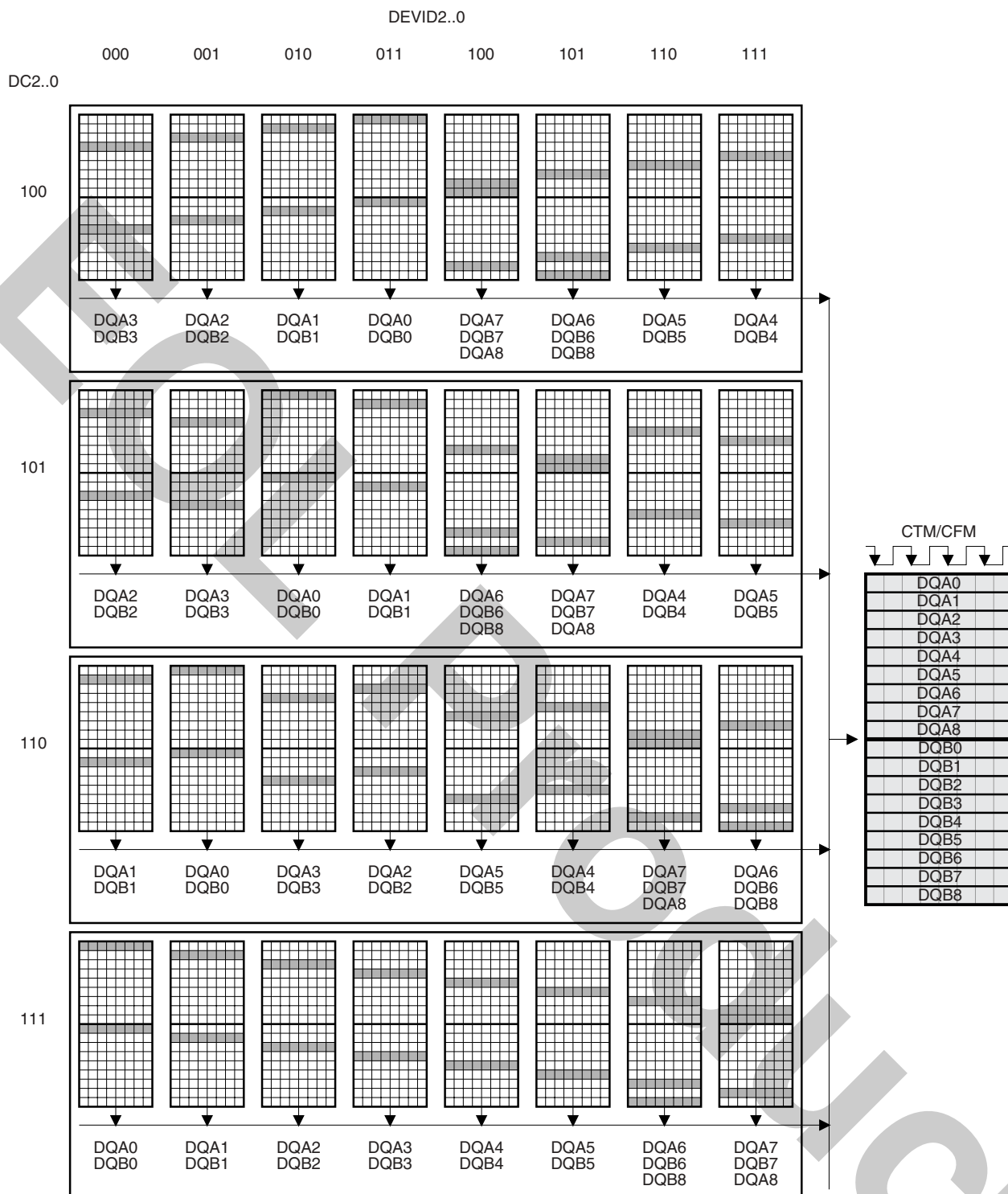



Figure 40-3 Mapping from DEVID2..0 and DC2..0 Fields to DQ Packet with IDM = 1 (continued)



## 41. Glossary of Terms

ACT	Activate command from AV field.	D	Write data packet on DQ pins.
activate	To access a row and place in sense amp.	DBL	CNFGB register field – doubled-bank.
activate	To access a row and place in sense amp.	DC	Device address field in COLC packet.
adjacent	Two RDRAM banks which share sense amps (also called doubled banks).	device	An RDRAM on a Channel.
ASYM	CCA register field for RSL VOL / VOH.	DEVID	Control register with device address that is matched against DR, DC, and DX fields.
ATTN	Power state – ready for ROW / COL packets.	DM	Device match for ROW packet decode.
ATTNR	Power state – transmitting Q packets.	Doubled-bank	RDRAM with shared sense amp.
ATTNW	Power state – receiving D packets.	DQ	DQA and DQB pins.
AV	Opcode field in ROW packets.	DQA	Pins for data byte A.
bank	A block of $2^{\text{RBIT}} \cdot 2^{\text{CBIT}}$ storage cells in the core of the RDRAM.	DQB	Pins for data byte B.
BC	Bank address field in CLC packet.	DQS	NAPX register field – PDN/NAP exit.
BBIT	CNFGA register field - # bank address bits.	DR,DR4T,DR4F	Device address field and packet framing fields in ROW and ROWE packets.
broadcast	An operation executed by all RDRAM devices.	dualoct	16 bytes – the smallest addressable datum.
BR	Bank address field in ROW packets.	DX	Device address field in COLX packet.
bubble	Idle cycle(s) on RDRAM pins needed because of a resource constraint.	field	A collection of bits in a packet.
BYT	CNFGB register field – 9 bits per byte.	INIT	Control register with initialization fields.
BX	Bank address field in COLX packet.	initialization	Configuring a Channel of RDRAM devices so they are ready to respond to transactions.
C	Column address field in COLC packet.	LSR	CNFGA register field – low-power self-refresh.
CAL	Calibrate (IoL) command in XOP field.	M	Mask opcode field (COLM/COLX packet).
CBIT	CNFGB register field - # column address bits.	MA	Field in COLM packet for masking byte A.
CCA	Control register – current control A.	MB	Field in COLM packet for masking byte B.
CCB	Control register – current control B.	MSK	Mask command in M field.
CFM,CFMN	Clock pins for receiving packets.	MVER	Control register – manufacturer ID.
Channel	ROW / COL / DQ pins and external wires.	NAP	Power state – needs SCK/CMD wakeup.
CLRR	Clear reset command from SOP field.	NAPR	Nap command in ROP field.
CMD	CMOS pins for initialization / power control.	NAPRC	Conditional nap command in ROP field.
CNFGA	Control register with configuration fields.	NAPXA	NAPX register field – NAP exit delay A.
CNFGB	Control register with configuration fields.	NAPXB	NAPX register field – NAP exit delay B.
COL	Pins for column-access control.	NOCOP	No-operation command in COP field.
COLC	Column operation packet on COL pins.	NOROP	No-operation command in ROP field.
COLM	Write mask packet on COL pins.	NOXOP	No-operation command in XOP field.
column	Rows in a bank or activated in sense amps have $2^{\text{CBIT}}$ dualocts column storage.	NSR	INIT register field – NAP self-refresh.
Command	A decoded bit-combination from a field.	packet	A collection of bits carried on the Channel.
COLX	Extended operation packet on COL pins.	PDN	Power state – needs SCK/CMD wakeup.
controller	A logic-device which drives the ROW / COL / DQ wires for a Channel of RDRAM devices.	PDNR	Powerdown command in ROP field.
COP	Column opcode field in COLC packet.	PDNXA	Control register – PDN exit delay A.
core	The banks and sense amps of an RDRAM.	PDNXB	Control register – PDN exit delay B.
CTM, CTMN	Clock pins for transmitting packets.	pin efficiency	The fraction of non-idle cycles on a pin.
Current control	Periodic operations to update the proper IoL Value of RSL output drivers.	PRE	PREC, PRER, PREX precharge commands.
		PREC	Precharge command in COP field.
		precharge	Prepares sense amp and bank for activate.
		PRER	Precharge command in ROP field.

PREX	Precharge command in XOP field.	SETF	Set fast clock command from SOP field.
PSX	INIT register field – PDN/NAP exit.	SETR	Set reset command from SOP field.
PSR	INIT register field – PDN self-refresh.	SINT	Serial interval packet for control register read/write transactions.
PVER	CNFGB register field – protocol version.	SIO0,SIO1	CMOS serial pins for control registers.
Q	Read data packet on DQ pins.	SOP	Serial opcode field in SRQ.
R	Row address field of ROWA packet.	SRD	Serial read opcode command from SOP.
RBIT	CNFGB register field - #row address bits.	SRP	INIT register field – Serial repeat bit.
RD/RDA	Read (/precharge) command in COP field.	SRQ	Serial request packet for control register read/write transactions.
read	Operation of accessing sense amp data.	STBY	Power state – ready for ROW packets.
receive	Moving information from the Channel into the RDRAM (a serial stream is demuxed).	SVER	Control register – stepping version.
REFA	Refresh-activate command in ROP field.	SWR	Serial write opcode command from SOP.
REFB	Control register – next bank (self-refresh).	TCAS	TCLSCAS register field – tcas core delay.
REFBIT	CNFGA register field – ignore bank bits (for REFA and self-refresh).	TCLS	TCLSCAS register field – tcls core delay.
REFP	Refresh-precharge command in ROP field.	TCLSCAS	Control register – tcas and tcls delay.
REFR	Control register – next row for REFA.	TCYCLE	Control register – tcycle delay.
refresh	Periodic operations to restore storage cells.	TDAT	Control register – tdac delay.
retire	The automatic operation that stores write buffer into sense amp after WR command.	TEST77	Control register – for test purposes.
RLX	RLXC, RLXR, RLXX relax commands.	TEST78	Control register – for test purposes.
RLXC	Relax command in COP field.	TRDLY	Control register – trdly delay.
RLXR	Relax command in ROP field.	transaction	ROW, COL, DQ packets for memory access.
RLXX	Relax command in XOP field.	transmit	Moving information from the RDRAM onto the Channel (parallel word is muxed).
ROP	Row-opcode field in ROPR packet.	WR/WRA	Write (/precharge) command in COP field.
row	2 <sup>CBIT</sup> dualocts of cells (bank/sense amp).	write	Operation of modifying sense amp data.
ROW	Pins for row-access control	XOP	Extended opcode field in COLX packet.
ROW	ROWA or ROWR packets on ROW pins.		
ROWA	Activate packet on ROW pins.		
ROWR	Row operation packet on ROW pins.		
RQ	Alternate name for ROW/COL pins.		
RSL	Rambus Signal levels.		
SAM	Sample (IoL) command in XOP field.		
SA	Serial address packet for control register transactions w/ SA address field.		
SBC	Serial broadcast field in SRQ.		
SCK	CMOS clock pin.		
SD	Serial data packet for control register transactions w/ SD data field.		
SDEV	Serial device address in SRQ packet.		
SDEVID	INIT register field – Serial device ID.		
self-refresh	Refresh mode for PDN and NAP.		
sense amp	Fast storage that holds copy of bank's row.		

42. Package Drawing

80-ball FBGA

EDR2518ABSE: Sn-Pb solder ball

EDR2518ABSE-E: Lead free solder ball (Sn-Ag-Cu)

Unit: mm

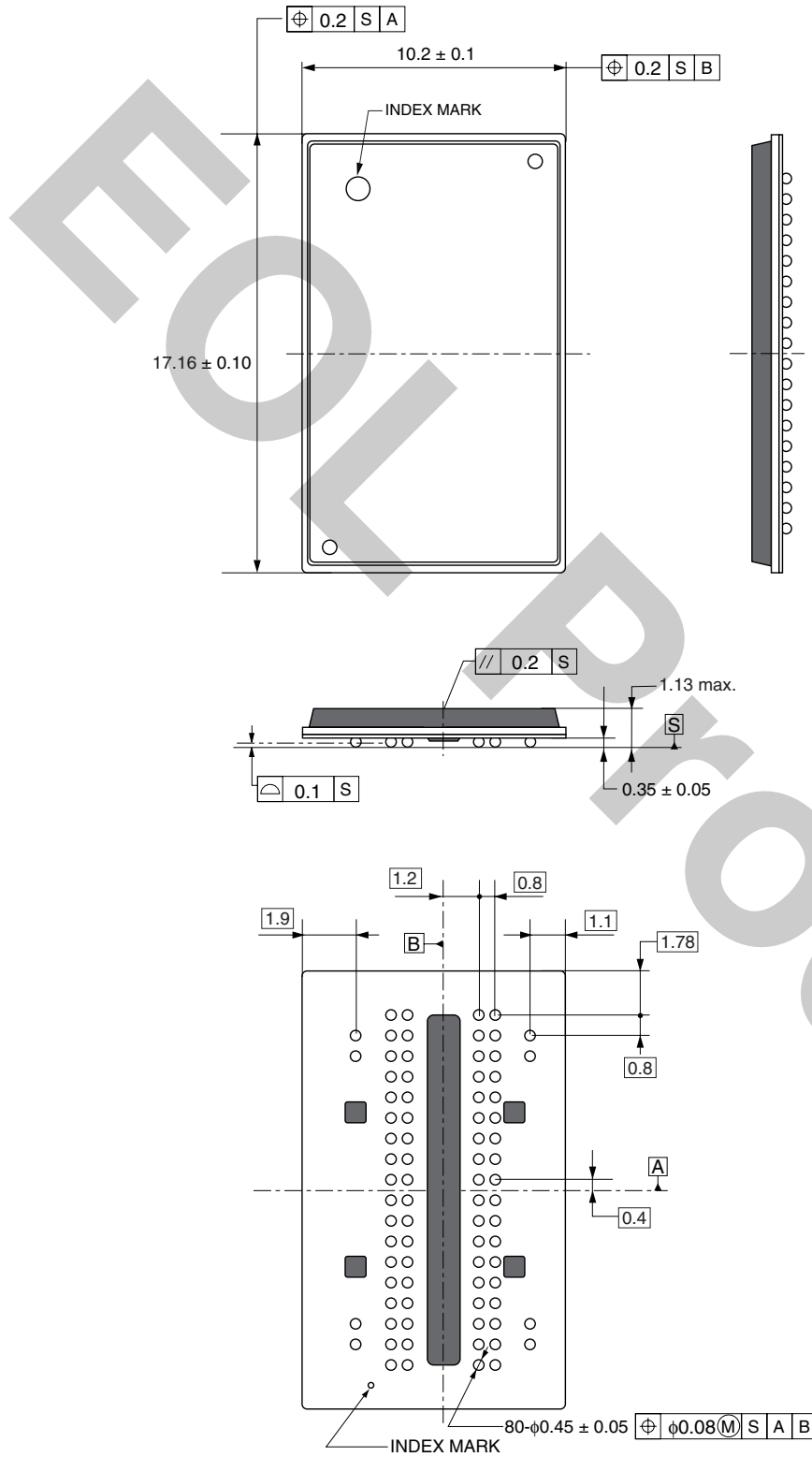

ECA-TS2-0089-01

### 43. Recommended Soldering Conditions

Please consult our sales office for soldering conditions of the EDR2518ABSE.

#### Type of Surface Mount Device

EDR2518ABSE: 80-ball FBGA < Sn-Pb > ,

EDR2518ABSE-E: 80-ball FBGA < Lead free (Sn-Ag-Cu) >

FOR Product

**NOTES FOR CMOS DEVICES****① PRECAUTION AGAINST ESD FOR MOS DEVICES**

Exposing the MOS devices to a strong electric field can cause destruction of the gate oxide and ultimately degrade the MOS devices operation. Steps must be taken to stop generation of static electricity as much as possible, and quickly dissipate it, when once it has occurred. Environmental control must be adequate. When it is dry, humidifier should be used. It is recommended to avoid using insulators that easily build static electricity. MOS devices must be stored and transported in an anti-static container, static shielding bag or conductive material. All test and measurement tools including work bench and floor should be grounded. The operator should be grounded using wrist strap. MOS devices must not be touched with bare hands. Similar precautions need to be taken for PW boards with semiconductor MOS devices on it.

**② HANDLING OF UNUSED INPUT PINS FOR CMOS DEVICES**

No connection for CMOS devices input pins can be a cause of malfunction. If no connection is provided to the input pins, it is possible that an internal input level may be generated due to noise, etc., hence causing malfunction. CMOS devices behave differently than Bipolar or NMOS devices. Input levels of CMOS devices must be fixed high or low by using a pull-up or pull-down circuitry. Each unused pin should be connected to  $V_{DD}$  or GND with a resistor, if it is considered to have a possibility of being an output pin. The unused pins must be handled in accordance with the related specifications.

**③ STATUS BEFORE INITIALIZATION OF MOS DEVICES**

Power-on does not necessarily define initial status of MOS devices. Production process of MOS does not define the initial operation status of the device. Immediately after the power source is turned ON, the MOS devices with reset function have not yet been initialized. Hence, power-on does not guarantee output pin levels, I/O settings or contents of registers. MOS devices are not initialized until the reset signal is received. Reset operation must be executed immediately after power-on for MOS devices having reset function.

CME0107

**Rambus, RDRAM and the Rambus logo are registered trademarks of Rambus Inc.**

**Direct Rambus, Direct RDRAM, RIMM, SO-RIMM and QRSL are trademarks of Rambus Inc.**

The information in this document is subject to change without notice. Before using this document, confirm that this is the latest version.

No part of this document may be copied or reproduced in any form or by any means without the prior written consent of Elpida Memory, Inc.

Elpida Memory, Inc. does not assume any liability for infringement of any intellectual property rights (including but not limited to patents, copyrights, and circuit layout licenses) of Elpida Memory, Inc. or third parties by or arising from the use of the products or information listed in this document. No license, express, implied or otherwise, is granted under any patents, copyrights or other intellectual property rights of Elpida Memory, Inc. or others.

Descriptions of circuits, software and other related information in this document are provided for illustrative purposes in semiconductor product operation and application examples. The incorporation of these circuits, software and information in the design of the customer's equipment shall be done under the full responsibility of the customer. Elpida Memory, Inc. assumes no responsibility for any losses incurred by customers or third parties arising from the use of these circuits, software and information.

**[Product applications]**

Elpida Memory, Inc. makes every attempt to ensure that its products are of high quality and reliability. However, users are instructed to contact Elpida Memory's sales office before using the product in aerospace, aeronautics, nuclear power, combustion control, transportation, traffic, safety equipment, medical equipment for life support, or other such application in which especially high quality and reliability is demanded or where its failure or malfunction may directly threaten human life or cause risk of bodily injury.

**[Product usage]**

Design your application so that the product is used within the ranges and conditions guaranteed by Elpida Memory, Inc., including the maximum ratings, operating supply voltage range, heat radiation characteristics, installation conditions and other related characteristics. Elpida Memory, Inc. bears no responsibility for failure or damage when the product is used beyond the guaranteed ranges and conditions. Even within the guaranteed ranges and conditions, consider normally foreseeable failure rates or failure modes in semiconductor devices and employ systemic measures such as fail-safes, so that the equipment incorporating Elpida Memory, Inc. products does not cause bodily injury, fire or other consequential damage due to the operation of the Elpida Memory, Inc. product.

**[Usage environment]**

This product is not designed to be resistant to electromagnetic waves or radiation. This product must be used in a non-condensing environment.

If you export the products or technology described in this document that are controlled by the Foreign Exchange and Foreign Trade Law of Japan, you must follow the necessary procedures in accordance with the relevant laws and regulations of Japan. Also, if you export products/technology controlled by U.S. export control regulations, or another country's export control laws or regulations, you must follow the necessary procedures in accordance with such laws or regulations.

If these products/technology are sold, leased, or transferred to a third party, or a third party is granted license to use these products, that third party must be made aware that they are responsible for compliance with the relevant laws and regulations.