

Dual JK Negative Edge-Triggered Flip-Flop

The 74LS107A is a Dual JK Flip-Flop with individual J, K, Direct Clear and Clock Pulse inputs. Output changes are initialized by the HIGH-to-LOW transition of the clock. A LOW signal on Clear input overrides the other inputs and makes the Q output LOW.

- AVG's LS operates over extended Vcc from 4.5 to 5.5 V
- AVG's LS and ALS both have guaranteed DC and AC specification over full temperature and Vcc range
- Switching specifications for ALS at 50 pF
- AVG's ALS has the lowest speed power product (4pJ per gate typical) of all logic series

DV74LS107A DV74ALS107

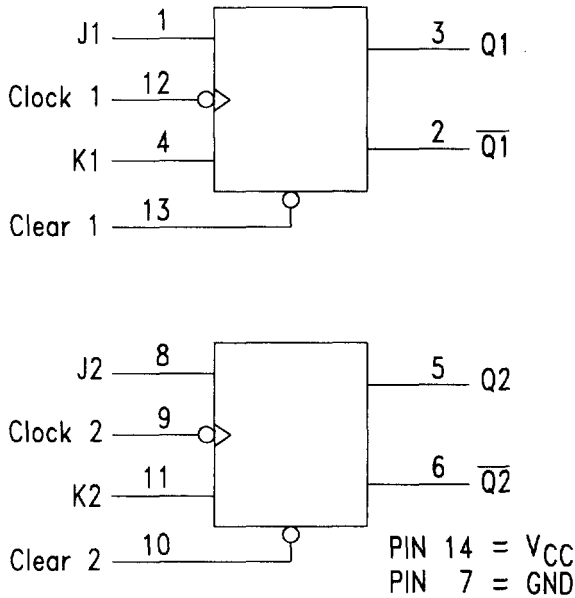
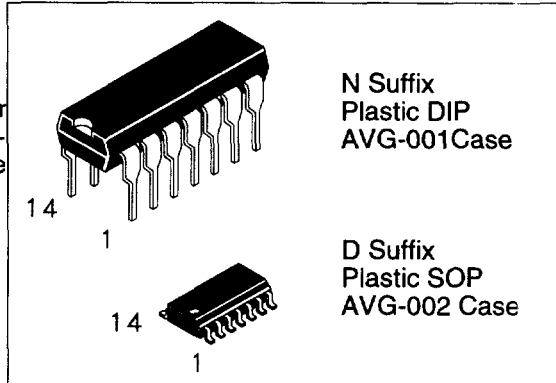

PIN ASSIGNMENT

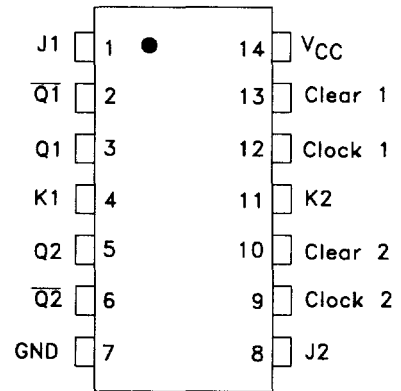

TRUTH TABLE

Operating Mode	Inputs			Outputs	
	Clear	J	K	Q	\bar{Q}
Reset (Clear)	L	X	X	L	H
Toggle	H	h	h	\bar{q}	q
Load "0" (Reset)	H	l	h	L	H
Load "1" (Set)	H	h	l	H	L
Hold	H	l	l	q	\bar{q}

H, h = HIGH Voltage Level

L, l = LOW Voltage Level

X = Don't Care

l, h, q = the state of referenced input or output one set-up time prior to the HIGH to LOW clock transition

ABSOLUTE MAXIMUM RATINGS

Maximum ratings are those values beyond which damage to the device may occur.

Symbol	Parameter	LS107A	ALS107	Unit
V _{CC}	Supply Voltage	7.0	7.0	V
V _{IN}	Input Voltage	7.0	7.0	V
T _{STG}	Storage Temperature Range	-65 to+150	-65 to + 150	°C

107A

GUARANTEED OPERATING CONDITIONS

Symbol	Parameter	LS107A		ALS107		Unit
		Min	Max	Min	Max	
V _{CC}	Supply Voltage	4.5	5.5	4.5	5.5	V
V _{IH}	High Level Input Voltage	2.0		2.0		V
V _{IL}	Low Level Input Voltage		0.8		0.8	V
I _{OH}	High Level Output Current		-0.4		-0.4	mA
I _{OL}	Low Level Output Current		8.0		8.0	mA
T _A	Ambient Temperature Range	-10 to +70		-10 to + 70		°C

DC ELECTRICAL CHARACTERISTICS over full operating conditions

Symbol	Parameter		Conditions	LS107A			ALS107			Unit
				Min	Typ	Max	Min	Typ	Max	
V _{IK}	Input Clamp Voltage		V _{CC} =min, I _{IN} = -18 mA			-1.5			-1.5	V
V _{OH}	High Level Output Voltage		V _{CC} =min, I _{OH} = max	V _{CC} -2	3.5		V _{CC} -2			V
V _{OL}	Low Level Output Voltage		V _{CC} =min; I _{OL} =4.0mA		0.25	0.4		0.25	0.4	V
			V _{CC} =min; I _{OL} =8.0 mA		0.35	0.5		0.35	0.5	V
I _{IH}	High Level Input Current	J, K Clear Clock	V _{CC} =max, V _{IN} =2.7V			20 60 80			20 60 80	μA
	High Level Input Current	J, K Clear Clock	V _{CC} =max, V _{IN} = 7.0V			0.1 0.3 0.4			0.1 0.3 0.4	mA
I _{IL}	Low Level Input Current	J, K Clear and Clock	V _{CC} =max, V _{IN} =0.4V			-0.4 -0.8			-0.1 -0.2	mA
I _O	Short Circuit Current One output shorted at a time		V _{CC} =max; V _O =2.2.5V	-20		-110	-30		-112	mA
I _{CC}	Supply Current		V _{CC} =max			6.0			4.0	mA

SWITCHING CHARACTERISTICS over full operating conditions

Symbol	Parameter		Limits C _L =15pF		Limits C _L =50pF R _L =500Ω		Unit
			Min	Max	Min	Max	
f _{MAX}	Maximum Clock Frequency		30		38		MHz
t _{PLH}	Propagation Delay, Clock to Output			20		14	ns
t _{PHL}				20		14	

AC SETUP REQUIREMENTS over full operating conditions

Symbol	Parameter	LS107A		ALS107		Unit
		Min	Max	Min	Max	
t_w	Pulse Width	Clock	20		12	ns
		Clear	25		15	ns
t_s	Data Setup Time	20		12		ns
t_h	Hold Time	0		0		ns

SWITCHING WAVEFORMS

