

8961723 0093404 T13 T113
SN54ABT18646A, SN74ABT18646A
SCAN TEST DEVICES WITH
18-BIT TRANSCEIVERS AND REGISTERS

SCBS166 - AUGUST 1993

- Members of the Texas Instruments **SCOPE™** Family of Testability Products
- Members of the Texas Instruments **Widebus™** Family
- Compatible With the IEEE Standard 1149.1-1990 (JTAG) Test Access Port and Boundary-Scan Architecture
- Include D-Type Flip-Flops and Control Circuitry to Provide Multiplexed Transmission of Stored and Real-Time Data
- Bus-Hold Data Inputs Eliminate the Need for External Pullup Resistors
- State-of-the-Art **EPIC-IIB™** BICMOS Design Significantly Reduces Power Dissipation
- One Boundary-Scan Cell per I/O Architecture Improves Scan Efficiency
- **SCOPE™** Instruction Set
 - IEEE Standard 1149.1-1990 Required Instructions and P1149.1A CLAMP and HIGHZ
 - Parallel Signature Analysis at Inputs
 - Pseudo-Random Pattern Generation From Outputs
 - Sample Inputs/Toggle Outputs
 - Binary Count From Outputs
 - Device Identification
 - Even-Parity Opcodes
- Packaged in 64-Pin Plastic Thin Quad Flat Packages Using 0.5-mm Center-to-Center Spacings and 68-Pin Ceramic Quad Flat Packages Using 25-mil Center-to-Center Spacings

SN54ABT18646A . . . HV PACKAGE
 (TOP VIEW)

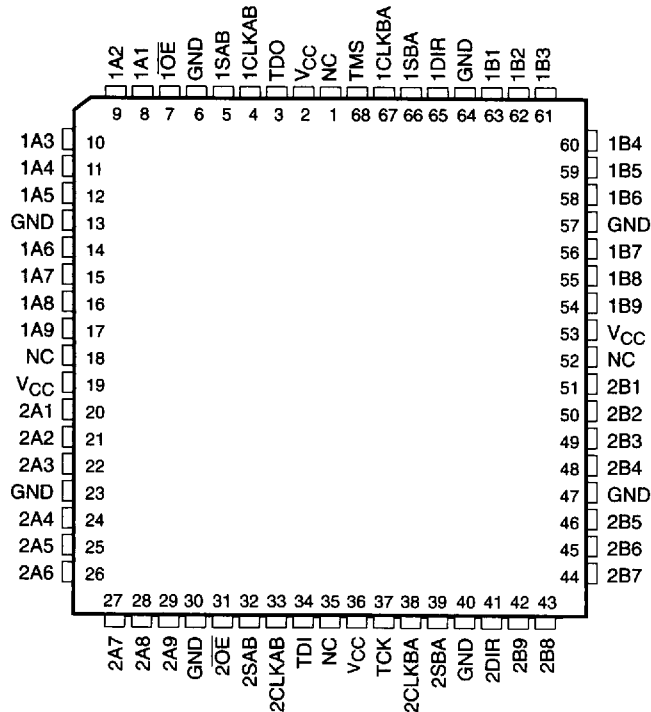

NC - No internal connection

PRODUCT PREVIEW

SCOPE, Widebus, and EPIC-IIB are trademarks of Texas Instruments Incorporated.

PRODUCT PREVIEW information concerns products in the formative or design phase of development. Characteristic data and other specifications are design goals. Texas Instruments reserves the right to change or discontinue these products without notice.



POST OFFICE BOX 655303 • DALLAS, TEXAS 75265

Copyright © 1993, Texas Instruments Incorporated

SN54ABT18646A, SN74ABT18646A
SCAN TEST DEVICES WITH
18-BIT TRANSCEIVERS AND REGISTERS

SCBS166 - AUGUST 1993

SN74ABT18646A . . . PM PACKAGE
(TOP VIEW)

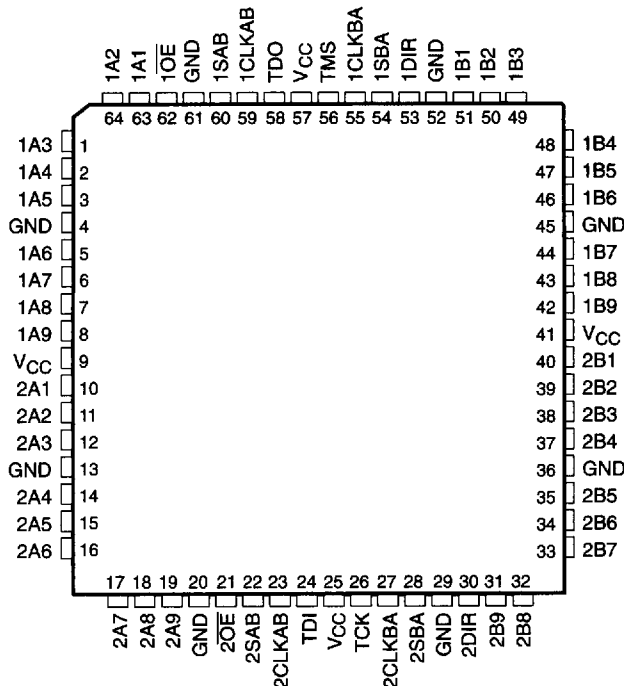

PRODUCT PREVIEW

description

The SN54ABT18646A and SN74ABT18646A scan test devices with 18-bit bus transceivers and registers are members of the Texas Instruments SCOPE™ testability IC family. This family of devices supports IEEE Standard 1149.1-1990 boundary scan to facilitate testing of complex circuit board assemblies. Scan access to the test circuitry is accomplished via the 4-wire test access port (TAP) interface.

In the normal mode, these devices are 18-bit bus transceivers and registers that allow for multiplexed transmission of data directly from the input bus or from the internal registers. They can be used either as two 9-bit transceivers or one 18-bit transceiver. The test circuitry can be activated by the TAP to take snapshot samples of the data appearing at the device pins or to perform a self test on the boundary test cells. Activating the TAP in the normal mode does not affect the functional operation of the SCOPE™ bus transceivers and registers.

Transceiver function is controlled by output-enable (\overline{OE}) and direction (DIR) inputs. When \overline{OE} is low, the transceiver is active and operates in the A-to-B direction when DIR is high or in the B-to-A direction when DIR is low. When \overline{OE} is high, both the A and B outputs are in the high-impedance state, effectively isolating both buses.

Data flow is controlled by clock (CLKAB and CLKBA) and select (SAB and SBA) inputs. Data on the A bus is clocked into the associated registers on the low-to-high transition of CLKAB. When SAB is low, real-time A data is selected for presentation to the B bus (transparent mode). When SAB is high, stored A data is selected for presentation to the B bus (registered mode). The function of the CLKBA and SBA inputs mirrors that of CLKAB and SAB, respectively. Figure 1 illustrates the four fundamental bus-management functions that can be performed with the 'ABT18646A.



**SN54ABT18646A, SN74ABT18646A
SCAN TEST DEVICES WITH
18-BIT TRANSCEIVERS AND REGISTERS**

SCBS166 - AUGUST 1993

description (continued)

In the test mode, the normal operation of the SCOPE™ bus transceivers and registers is inhibited, and the test circuitry is enabled to observe and control the I/O boundary of the device. When enabled, the test circuitry can perform boundary scan test operations according to the protocol described in IEEE Standard 1149.1-1990.

Four dedicated test pins are used to observe and control the operation of the test circuitry: test data input (TDI), test data output (TDO), test mode select (TMS), and test clock (TCK). Additionally, the test circuitry can perform other testing functions such as parallel signature analysis on data inputs and pseudo-random pattern generation from data outputs. All testing and scan operations are synchronized to the TAP interface.

Improved scan efficiency is accomplished through the adoption of a one boundary-scan cell (BSC) per I/O pin architecture. This architecture is implemented in such a way as to capture test data of most interest. A PSA/COUNT instruction is also included to ease the testing of memories and other circuits where a binary count addressing scheme is useful.

The SN54ABT18646A is characterized for operation over the full military temperature range of -55°C to 125°C. The SN74ABT18646A is characterized for operation from -40°C to 85°C.

FUNCTION TABLE
(normal mode, each 9-bit section)

INPUTS						DATA I/O		OPERATION OR FUNCTION
OE	DIR	CLKAB	CLKBA	SAB	SBA	A1 THRU A9	B1 THRU B9	
X	X	↑	X	X	X	Input	Unspecified†	Store A, B unspecified†
X	X	X	↑	X	X	Unspecified†	Input	Store B, A unspecified†
H	X	↑	↑	X	X	Input	Input	Store A and B data
H	X	L	L	X	X	Input disabled	Input disabled	Isolation, hold storage
L	L	X	X	X	L	Output	Input	Real-time B data to A bus
L	L	X	L	X	H	Output	Input disabled	Stored B data to A bus
L	H	X	X	L	X	Input	Output	Real-time A data to B bus
L	H	L	X	H	X	Input disabled	Output	Stored A data to B bus

† The data output functions can be enabled or disabled by various signals at the OE and DIR inputs. Data input functions are always enabled; i.e., data at the bus pins will be stored on every low-to-high transition of the clock inputs.

PRODUCT PREVIEW

SN54ABT18646A, SN74ABT18646A
SCAN TEST DEVICES WITH
18-BIT TRANSCEIVERS AND REGISTERS
 SCBS166 - AUGUST 1993

PRODUCT PREVIEW

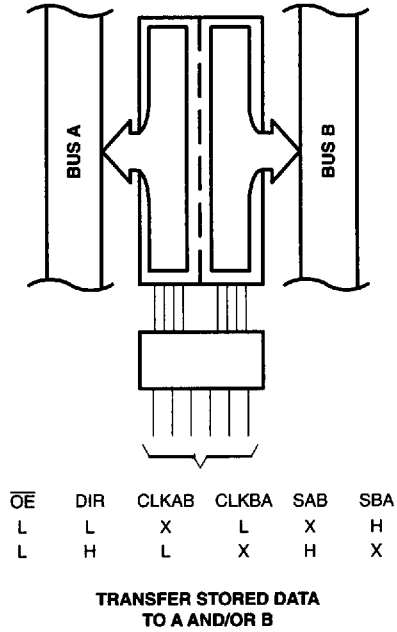
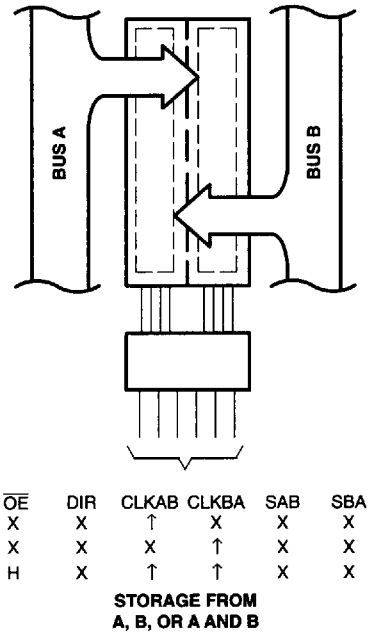
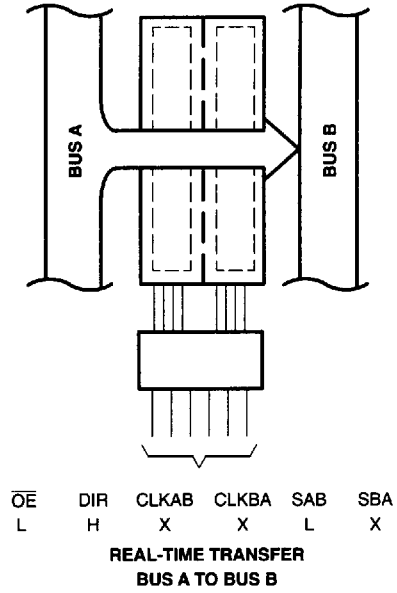
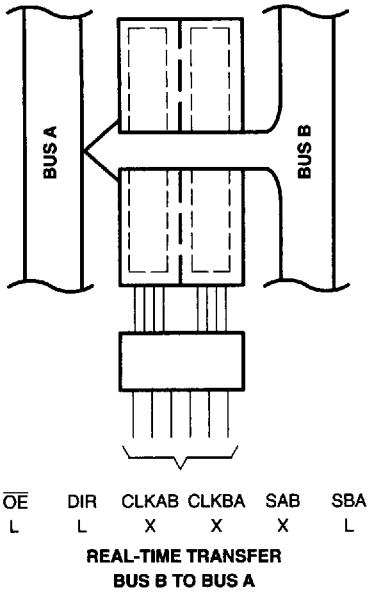
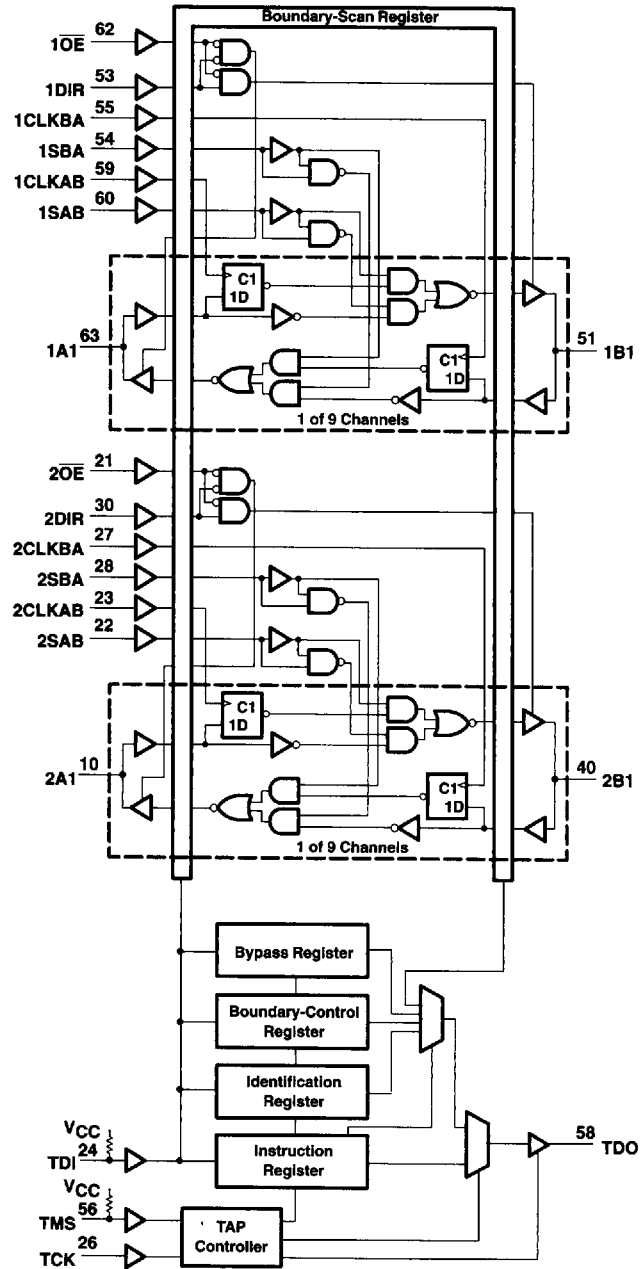

Figure 1. Bus-Management Functions

SN54ABT18646A, SN74ABT18646A SCAN TEST DEVICES WITH 18-BIT TRANSCEIVERS AND REGISTERS

SCBS166 - AUGUST 1993

functional block diagram



PRODUCT PREVIEW

Pin numbers shown are for the PM package.



SN54ABT18646A, SN74ABT18646A
SCAN TEST DEVICES WITH
18-BIT TRANSCEIVERS AND REGISTERS

SCBS166 - AUGUST 1993

absolute maximum ratings over operating free-air temperature range (unless otherwise noted)†

Supply voltage range, V_{CC}	-0.5 V to 7 V
Input voltage range, V_I (except I/O ports) (see Note 1)	-0.5 V to 7 V
Input voltage range, V_I (I/O ports) (see Note 1)	-0.5 V to 5.5 V
Voltage range applied to any output in the high state or power-off state, V_O	-0.5 V to 5.5 V
Current into any output in the low state, I_{OL} : SN54ABT18646A	96 mA
SN74ABT18646A	128 mA
Input clamp current, I_{IK} ($V_I < 0$)	-18 mA
Output clamp current, I_{OK} ($V_O < 0$)	-50 mA
Maximum package power dissipation at $T_A = 55^\circ\text{C}$ (in still air) (see Note 2)	885 mW
Storage temperature range	-65°C to 150°C

† Stresses beyond those listed under "absolute maximum ratings" may cause permanent damage to the device. These are stress ratings only, and functional operation of the device at these or any other conditions beyond those indicated under "recommended operating conditions" is not implied. Exposure to absolute-maximum-rated conditions for extended periods may affect device reliability.

- NOTES: 1. The input and output negative-voltage ratings may be exceeded if the input and output clamp-current ratings are observed.
 2. For the SN74ABT18646A (PM package), the power derating factor for ambient temperatures greater than 55°C is -10.5 mW/°C.

recommended operating conditions

	SN54ABT18646A		SN74ABT18646A		UNIT
	MIN	MAX	MIN	MAX	
V_{CC} Supply voltage	4.5	5.5	4.5	5.5	V
V_{IH} High-level input voltage	2		2		V
V_{IL} Low-level input voltage		0.8		0.8	V
V_I Input voltage	0	V_{CC}	0	V_{CC}	V
I_{OH} High-level output current		-24		-32	mA
I_{OL} Low-level output current		48		64	mA
$\Delta t/\Delta v$ Input transition rise or fall rate		10		10	ns/V
T_A Operating free-air temperature	-55	125	-40	85	°C

PRODUCT PREVIEW



SN54ABT18646A, SN74ABT18646A
 SCAN TEST DEVICES WITH
 18-BIT TRANSCEIVERS AND REGISTERS

SCBS166 - AUGUST 1993

electrical characteristics over recommended operating free-air temperature range (unless otherwise noted) (see Note 3)

PARAMETER	TEST CONDITIONS		T _A = 25°C			SN54ABT18646A		SN74ABT18646A		UNIT	
			MIN	TYP†	MAX	MIN	MAX	MIN	MAX		
V _{IK}	V _{CC} = 4.5 V, I _I = -18 mA		-1.2			-1.2		-1.2		V	
V _{OH}	V _{CC} = 4.5 V, I _{OH} = -3 mA		2.5			2.5		2.5		V	
	V _{CC} = 5 V, I _{OH} = -3 mA		3			3		3			
	V _{CC} = 4.5 V, I _{OH} = -24 mA		2			2					
	V _{CC} = 4.5 V, I _{OH} = -32 mA		2‡					2			
V _{OL}	V _{CC} = 4.5 V	I _{OL} = 48 mA	0.55			0.55				V	
		I _{OL} = 64 mA	0.55‡					0.55			
I _I	V _{CC} = 5.5 V, V _I = V _{CC} or GND	CLK, DIR, OE, S, TCK	±1			±1		±1		μA	
		A or B ports	±100			±100		±100			
I _{IH}	V _{CC} = 5.5 V, V _I = V _{CC}	TDI, TMS	10			10		10		μA	
I _{IL}	V _{CC} = 5.5 V, V _I = GND	TDI, TMS	-150			-150		-150		μA	
I _{I(hold)}	V _{CC} = 4.5 V	A or B ports	V _I = 0.8 V				100				μA
			V _I = 2 V				-100				
I _{OZH} §	V _{CC} = 5.5 V, V _O = 2.7 V		50			50		50		μA	
I _{OZL} §	V _{CC} = 5.5 V, V _O = 0.5 V		-50			-50		-50		μA	
I _{OZPU}	V _{CC} = 0 to 2 V, V _O = 2.7 V or 0.5 V	OE = 0.8 V	± 50			± 50		± 50		μA	
I _{OZPD}	V _{CC} = 0 to 2 V, V _O = 2.7 V or 0.5 V	OE = 0.8 V	± 50			± 50		± 50		μA	
I _{off}	V _{CC} = 0, V _I or V _O ≤ 4.5 V		±100			±450		±100		μA	
I _{CEX}	V _{CC} = 5.5 V, V _O = 5.5 V	Outputs high	50			50		50		μA	
I _O ¶	V _{CC} = 5.5 V, V _O = 2.5 V		-50	-110	-200	-50	-200	-50	-200	mA	
I _{CC}	V _{CC} = 5.5 V, I _O = 0, V _I = V _{CC} or GND	A or B ports	Outputs high	2	3	3		3		mA	
			Outputs low	16	22	22		22			
			Outputs disabled	1	1.5	1.5		1.5			
ΔI _{CC} #	V _{CC} = 5.5 V, One input at 3.4 V, Other inputs at V _{CC} or GND		1.5			1.5		1.5		mA	
C _i	V _I = 2.5 V or 0.5 V	Control inputs	3							pF	
C _{iO}	V _O = 2.5 V or 0.5 V	A or B ports	10							pF	
C _O	V _O = 2.5 V or 0.5 V	TDO	8							pF	

NOTE 3: Product preview specifications are design goals only and are subject to change without notice.

† All typical values are at V_{CC} = 5 V.

‡ On products compliant to MIL-STD-883, Class B, this parameter does not apply.

§ The parameters I_{OZH} and I_{OZL} include the input leakage current.

¶ Not more than one output should be tested at a time, and the duration of the test should not exceed one second.

This is the increase in supply current for each input that is at the specified TTL voltage level rather than V_{CC} or GND.

PRODUCT PREVIEW



SN54ABT18646A, SN74ABT18646A
SCAN TEST DEVICES WITH
18-BIT TRANSCEIVERS AND REGISTERS

SCBS166 - AUGUST 1993

timing requirements over recommended ranges of supply voltage and operating free-air temperature (unless otherwise noted) (normal mode) (see Note 3 and Figure 2)

			SN54ABT18646A		SN74ABT18646A		UNIT
			MIN	MAX	MIN	MAX	
f_{clock}	Clock frequency	CLKAB or CLKBA	0	100	0	100	MHz
t_w	Pulse duration	CLKAB or CLKBA high or low			4		ns
t_{su}	Setup time	A before CLKAB \uparrow or B before CLKBA \uparrow			4.5		ns
t_h	Hold time	A after CLKAB \uparrow or B after CLKBA \uparrow			0		ns

timing requirements over recommended ranges of supply voltage and operating free-air temperature (unless otherwise noted) (test mode) (see Note 3 and Figure 2)

			SN54ABT18646A		SN74ABT18646A		UNIT
			MIN	MAX	MIN	MAX	
f_{clock}	Clock frequency	TCK	0	50	0	50	MHz
t_w	Pulse duration	TCK high or low			8		ns
t_{su}	Setup time	A, B, CLK, DIR, \overline{OE} , or S before TCK \uparrow			4.5		ns
		TDI before TCK \uparrow			7.5		
		TMS before TCK \uparrow			4		
t_h	Hold time	A, B, CLK, DIR, \overline{OE} , or S after TCK \uparrow			0.5		ns
		TDI after TCK \uparrow			0.5		
		TMS after TCK \uparrow			0.5		
t_d	Delay time	Power up to TCK \uparrow			50		ns
t_r	Rise time	VCC power up			1		μ s

NOTE 3: Product preview specifications are design goals only and are subject to change without notice.

PRODUCT PREVIEW



SN54ABT18646A, SN74ABT18646A
SCAN TEST DEVICES WITH
18-BIT TRANSCEIVERS AND REGISTERS

SCBS166 - AUGUST 1993

switching characteristics over recommended ranges of supply voltage and operating free-air temperature (unless otherwise noted) (normal mode) (see Note 3 and Figure 2)

PARAMETER	FROM (INPUT)	TO (OUTPUT)	V _{CC} = 5 V, T _A = 25°C			SN54ABT18646A		SN74ABT18646A		UNIT
			MIN	TYP	MAX	MIN	MAX	MIN	MAX	
f _{max}	CLKAB or CLKBA		100	130		100		100		MHz
t _{PLH}	A or B	B or A						2	5.4	ns
t _{PHL}									2	
t _{PLH}	CLKAB or CLKBA	B or A						2.5	8	ns
t _{PHL}									2.5	
t _{PLH}	SAB or SBA	B or A						2	7.5	ns
t _{PHL}									2	
t _{PZH}	DIR	B or A						2	8	ns
t _{PZL}									3	
t _{PZH}	\overline{OE}	B or A						2.5	8.6	ns
t _{PZL}									3	
t _{PHZ}	DIR	B or A						3.5	11.1	ns
t _{PLZ}									3	
t _{PHZ}	\overline{OE}	B or A						3.5	10.5	ns
t _{PLZ}									2	

switching characteristics over recommended ranges of supply voltage and operating free-air temperature (unless otherwise noted) (test mode) (see Note 3 and Figure 2)

PARAMETER	FROM (INPUT)	TO (OUTPUT)	V _{CC} = 5 V, T _A = 25°C			SN54ABT18646A		SN74ABT18646A		UNIT
			MIN	TYP	MAX	MIN	MAX	MIN	MAX	
f _{max}	TCK		50	90		50		50		MHz
t _{PLH}	TCK↓	A or B						2.5	13.5	ns
t _{PHL}									2.5	
t _{PLH}	TCK↓	TDO						2	6.5	ns
t _{PHL}									2	
t _{PZH}	TCK↓	A or B						4.5	13.8	ns
t _{PZL}									5	
t _{PZH}	TCK↓	TDO						2	7	ns
t _{PZL}									3	
t _{PHZ}	TCK↓	A or B						4	17	ns
t _{PLZ}									3	
t _{PHZ}	TCK↓	TDO						3	9	ns
t _{PLZ}									3	

NOTE 3: Product preview specifications are design goals only and are subject to change without notice.

PRODUCT PREVIEW

SN54ABT18646A, SN74ABT18646A
SCAN TEST DEVICES WITH
18-BIT TRANSCEIVERS AND REGISTERS

SCBS166 - AUGUST 1993

PARAMETER MEASUREMENT INFORMATION

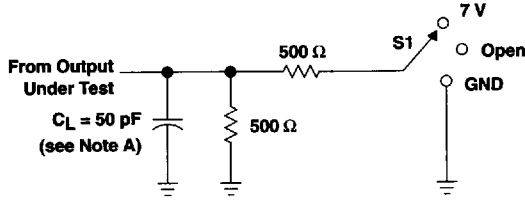

LOAD CIRCUIT FOR OUTPUTS

TEST	S1
t_{PLH}/t_{PHL}	Open
t_{PLZ}/t_{PZL}	7 V
t_{PHZ}/t_{PZH}	Open

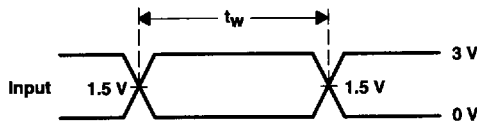

VOLTAGE WAVEFORMS
PULSE DURATION

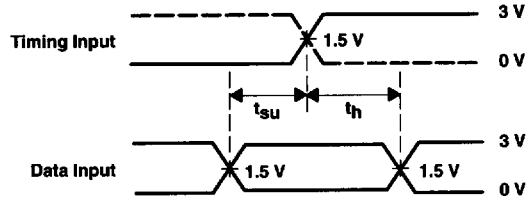

VOLTAGE WAVEFORMS
SETUP AND HOLD TIMES

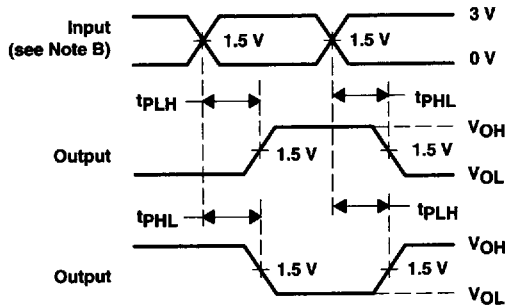

VOLTAGE WAVEFORMS
PROPAGATION DELAY TIMES
INVERTING AND NONINVERTING OUTPUTS

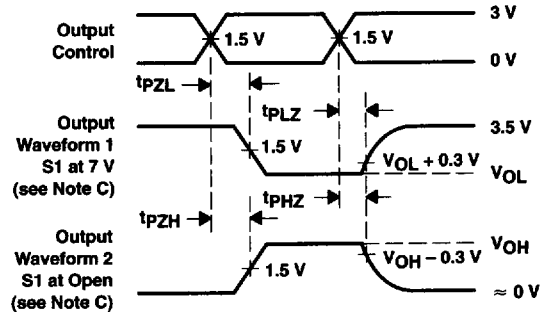

VOLTAGE WAVEFORMS
ENABLE AND DISABLE TIMES
LOW- AND HIGH-LEVEL ENABLING

- NOTES: A. C_L includes probe and jig capacitance.
 B. All input pulses are supplied by generators having the following characteristics: $PRR \leq 10$ MHz, $Z_O = 50 \Omega$, $t_r \leq 2.5$ ns, $t_f \leq 2.5$ ns.
 C. Waveform 1 is for an output with internal conditions such that the output is low except when disabled by the output control. Waveform 2 is for an output with internal conditions such that the output is high except when disabled by the output control.
 D. The outputs are measured one at a time with one transition per measurement.

Figure 2. Load Circuit and Voltage Waveforms

PRODUCT PREVIEW